

DESCRIPTION

M57160AL-01 is an optimal hybrid IC to drive trench gate IGBT module with built-in RTC. This IC is driven by two power supplies and provides the required electrical isolation between the input and output with an opto-coupler.

The protective system of this hybrid IC functions with a margin of time by built in protection circuits to maintain a reverse bias for a predetermined time after the detection of an over current (short-circuit). The over current (short-circuit) detector works with the RTC circuit built in IGBT module to detect a drop in this gate voltage for protection. If a gate pin of IGBT is connected with a detective pin of this hybrid IC, there is no need to use high withstand-voltage and high-speed diode or protective Zener diode for monitoring a collector voltage of IGBT.

Recommended module IGBT module with built-in RTC circuit (Mitsubishi F series)

OUTLINE DRAWING

Dimensions: mm

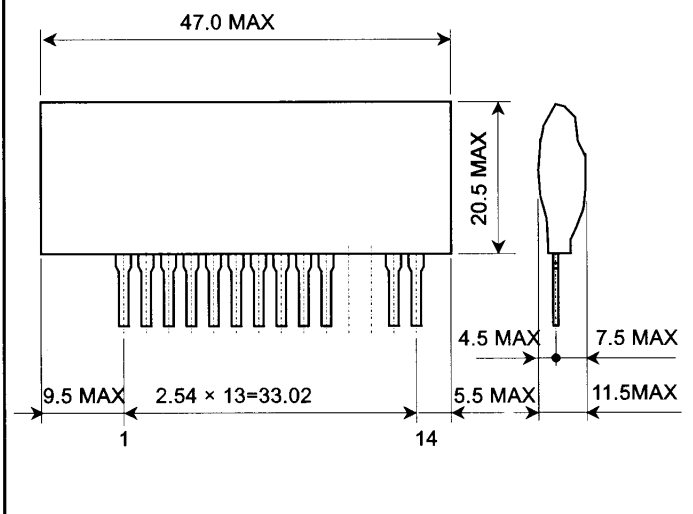
**FEATURES**

- High CMR opto-coupler built-in.
- Over current (short-circuit) protector built-in(with timer-operated circuit and reset circuit)
- Capability of adjusting time to control over current (short-circuit) detection
- Input-output isolation voltage: 2500Vrms for 1 min

APPLICATIONS

To drive IGBT modules for inverter or AC servo systems application.

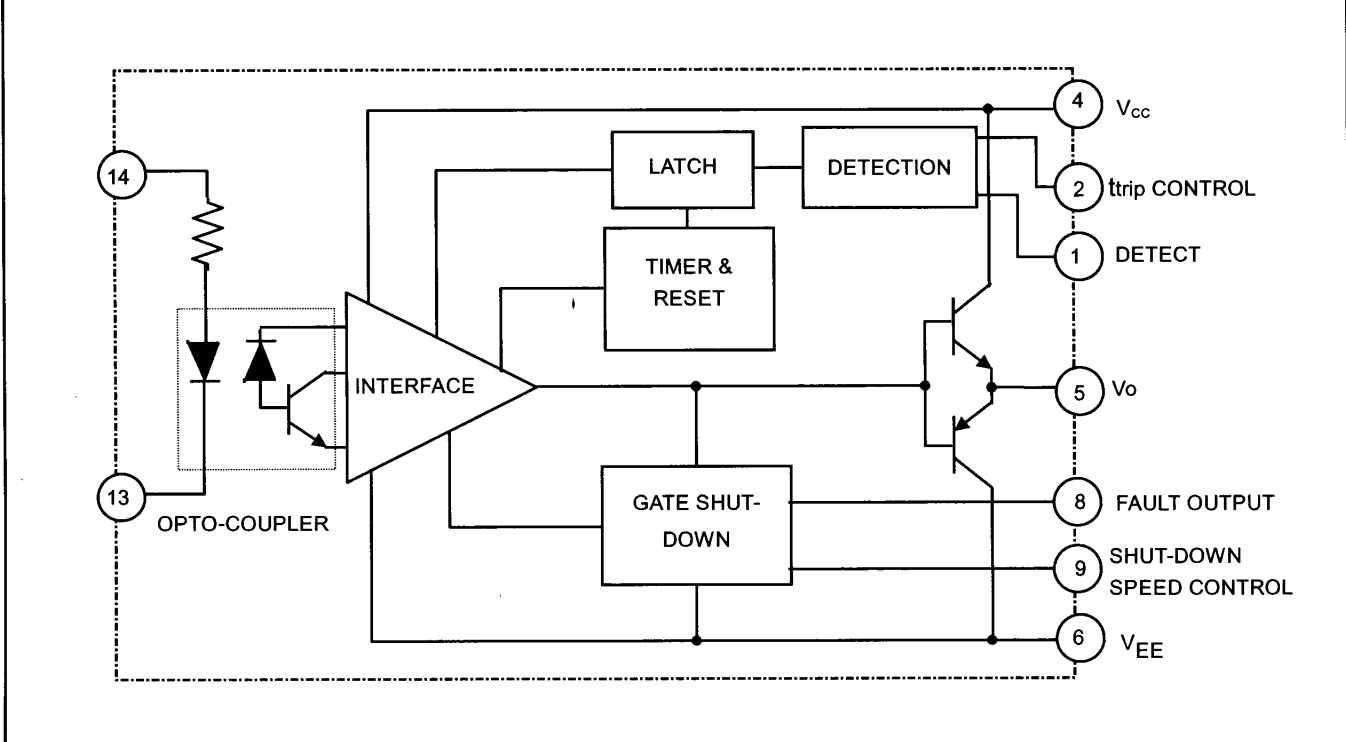
BLOCK DIAGRAM

MAXIMUM RATINGS (unless otherwise noted, $T_a=25^\circ\text{C}$)

Symbol	Parameter	Conditions	Ratings	Unit
V_{CC}	Supply voltage	DC	18	V
V_{EE}			-15	V
V_I	Input voltage	Applied between: 13pin and 14pin	-1 ~ +7	V
V_O	Output voltage	When the output voltage is "H"	V_{CC}	V
I_{OHP}	Output current	Pulse width 2us, $f \leq 20\text{kHz}$	-5	A
I_{OLP}			5	A
V_{ISO}	Isolation voltage	Sine wave voltage 60Hz, for 1min, $RH \leq 50\%$	2500	Vrms
T_c	Case temperature	—	85	$^\circ\text{C}$
T_{opr}	Operating temperature	No condensation allowable	-20 ~ +60	$^\circ\text{C}$
T_{stg}	Storage temperature	No condensation allowable	-25 ~ +100	$^\circ\text{C}$
I_{FO}	Fault output current	Inflow current at 8pin	20	mA
V_{R1}	Input voltage at 1pin	—	V_{CC}	V

ELECTRICAL CHARACTERISTICS (unless otherwise noted, $T_a=25^\circ\text{C}$, $V_{CC}=15\text{V}$, $V_{EE} = -5\text{V}$, $R_G = 2\text{ohm}$)

Symbol	Parameter	Conditions	Limits			Unit
			Min	Typ	Max	
V_{CC}	Supply voltage	Recommended range	14	15	—	V
V_{EE}			-3	-5	-10	V
V_{IN}	Pull-up voltage on primary side	Recommended range	4.75	5.00	5.25	V
I_{IH}	"H" input current	Recommended range	15.2	16.0	19.0	mA
f	Switching frequency	Recommended range (*)	—	—	20	kHz
R_G	Gate resistance	Recommended range	2	—	—	ohm
I_{IH}	"H" input current	$V_{IN} = 5\text{V}$	—	16	—	mA
V_{OH}	"H" output voltage	—	13	14	—	V
V_{OL}	"L" output voltage	—	-3	-4	—	V
t_{PLH}	"L-H" propagation time	$I_{IH} = 16\text{mA}$	—	0.4	1	us
t_r	"L-H" rise time	$I_{IH} = 16\text{mA}$	—	0.5	1	us
t_{PHL}	"H-L" propagation time	$I_{IH} = 16\text{mA}$	—	0.8	1.3	us
t_f	"H-L" fall time	$I_{IH} = 16\text{mA}$	—	0.4	1	us
t_{timer}	Timer	Between start and cancel (under input sign "L")	1	—	2	ms
I_{FO}	Fault output current	Inflow current at 8pin, $R = 3.9\text{ohm}$	—	5	—	mA
t_{trip1}	Controlled time defect over current 1	When the output rises, 1pin: 11.5V, 2pin: open	—	3.2	—	us
t_{trip2}	Controlled time detect over current 2(**)	When the output rises, 1pin: 11.5V, 2pin – 4pin: 22pF (connective capacitance)	—	5.1	—	us
V_{SC}	Over current detect voltage	Drop in a gate voltage with the RTC circuit built in IGBT	3	—	4	V

(*) At the time of IGBT module direct drive, recommended frequency may be set to 20kHz or less with the capacity of IGBT.

(**) The wiring length of the capacitor for changing over current detection controlled time makes less than 5cm of round trip between 2pin and 4pin.

TYPICAL CHARACTERISTICS

POWER DISSIPATION - AMBIENT TEMPERATURE
(MAXIMUM RATING)

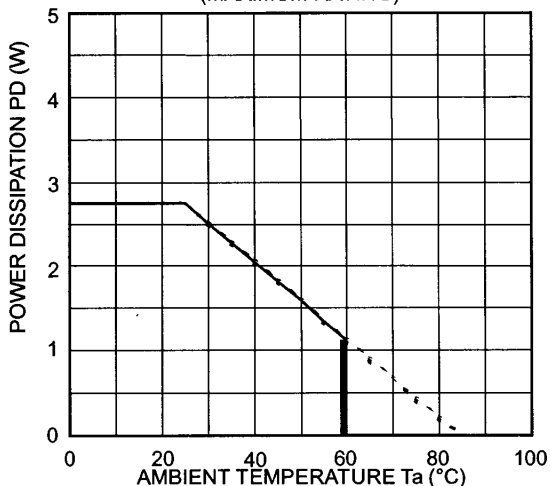

DISSIPATION CURRENT - SUPPLY VOLTAGE
CHARACTERISTICS (BETWEEN PIN 4-6)
INPUT SIGNAL "L" (TYPICAL)

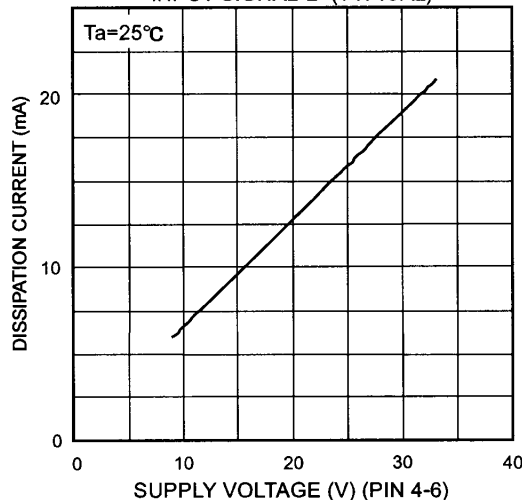

tPLH, tPHL - Ta CHARACTERISTICS
(TYPICAL)

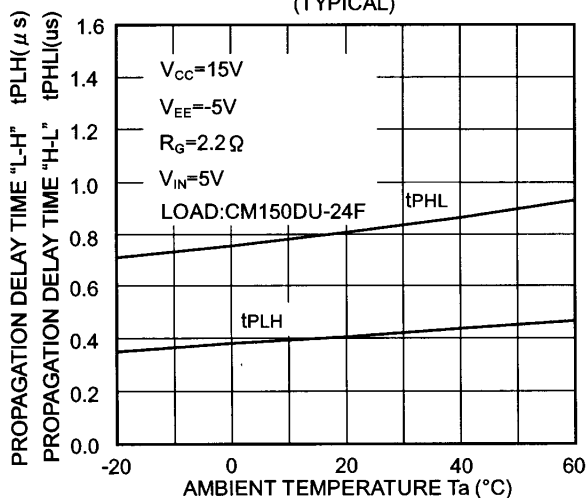

tPLH, tPHL - VI CHARACTERISTICS
(TYPICAL)

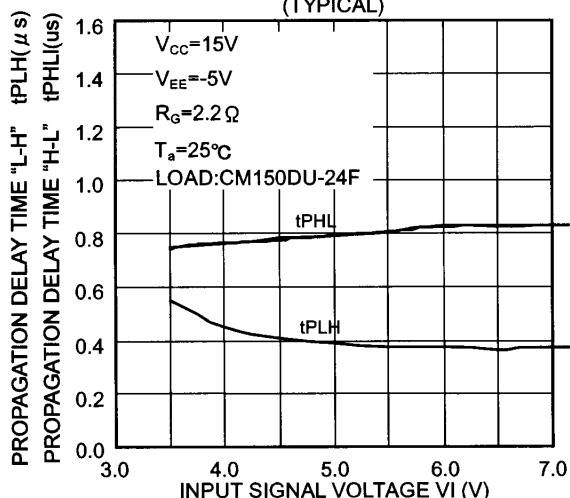

ttrip - Ctrip CHARACTERISTICS
(TYPICAL)

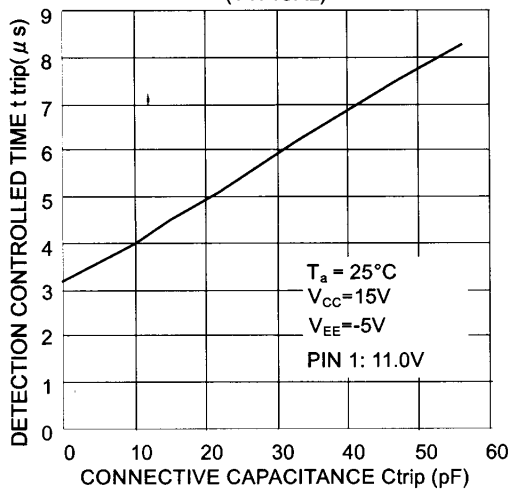

OPERATION OF PROTECTION CIRCUIT

- (1) The RTC circuit built in IGBT operates with overcurrent (short-circuit) and fall the gate voltage. If the difference between the gate voltage and gate voltage before the RTC circuit operate become 3V, output voltage is dropped in gradually. The fault sign is output ("L" level) from 8pin to indicate the protection circuit operating at the same time that the output voltage falls.
- (2) In about 1 ~ 2ms after this hybrid IC detect of overcurrent (short-circuit), if the input sign is "L", hybrid IC resets from the overcurrent protection condition and then restart switching operation. ("L" period needs up to 5us.)

OPERATION FLOW ON DETECTING SHORT CIRCUIT

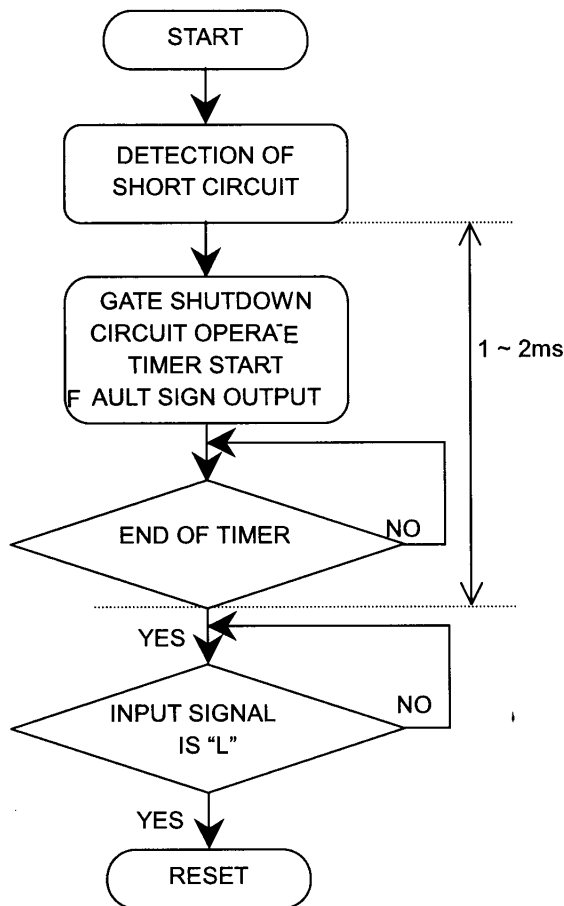

Note : "L" output voltage with protection circuit operating is about $V_{EE} + 2$

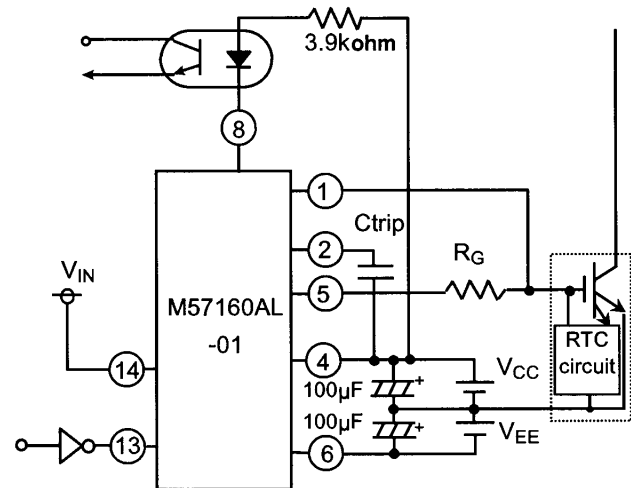

APPLICATION CIRCUIT EXAMPLE

- | | |
|---------------|--------------------------|
| TTLetc. | $V_{CC} = 15V$ |
| $f = 20kHz$ | $V_{EE} = -5V$ |
| D.F. = 50% | $R_G = 2.1ohm$ |
| $V_{IN} = 5V$ | $C_{trip} = 0 \sim 56pF$ |

PRECAUTION

- (1) Pin 3,7 and 10 are test pins. Don't use electrical contact with external devices.
- (2) Voltage compensate capacitors are provided as close as possible to this Hybrid IC.
- (3) If pin 2 is used, wires of Ctrip are wired as short as wires of between pin2 and 4 possible. (Standard: the total length is 5cm or less.)
- (4) When power supply turns on and off, input sign is kept at "L" voltage to prevent protection circuit from outputting by mistake.
- (5) When the protection function is not used such as driving IGBT built in no RTC circuit, pin 1 is non-connected.
- (6) When IGBT turns on, the RTC circuit built in IGBT operates with overcurrent (short-circuit) before the gate voltage become $V_{CC} - 2V$. If the drop in a gate voltage with the RTC circuit is less than 3V(standard), it takes the predetermined time (overcurrent detection controlled time: standard 3.2µs) till the protection circuit operates. If there is no overcurrent (short-circuit) state before it takes the predetermined time and RTC circuit is reseted, the protection circuit does not operate. The lower a gate voltage is dropped in with RTC circuit, the shorter overcurrent detection controlled time.

M57160AL-01

Hybrid IC for driving IGBT modules

DEFINITION OF CHARACTERISTICS

(1) SWITCHING OPERATION

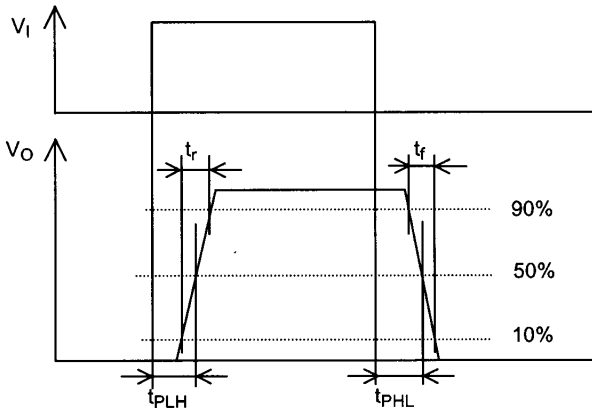

(2) OPERATION OF OVERCURRENT/ SHORT CIRCUIT PROTECTION

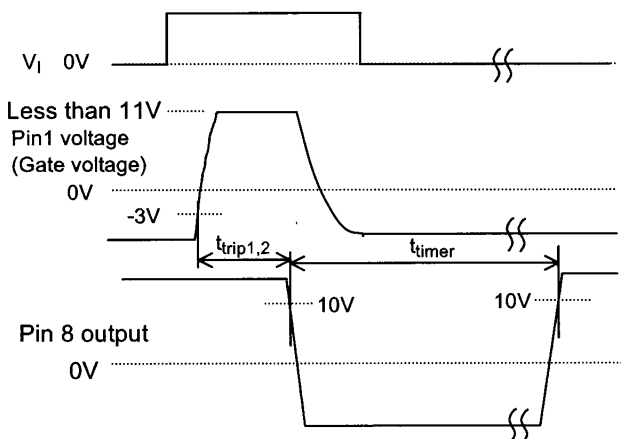

APPLICATION EXAMPLE OF SINGLE POWER SUPPLY

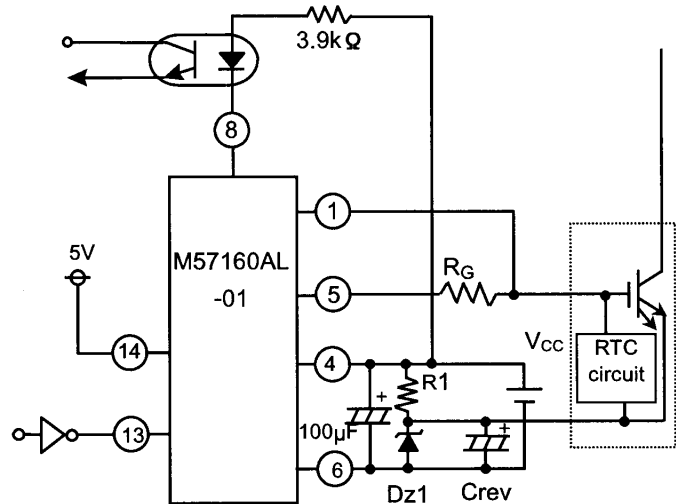

$V_{CC} = 20V$

$R1 = 3.3k\Omega$

Dz1 zener voltage: 5.1V

(*) Don't input the on sign till the provided ($R1 \times C_{rev}(s)$) time is passed over after power supply turns on.

APPLICATION EXAMPLE OF HIGH POWER MODULE

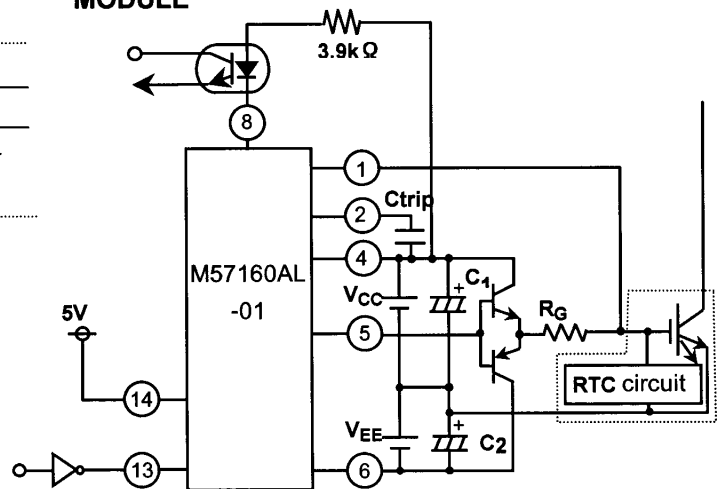

$V_{CC} = 15V$

$V_{EE} = -5V$

$C_{trip} = 0 \sim 56pF$

$C1, C2 \geq 100\mu F$

(*) The over-current detection controlled time can be adjusted by connection capacitor (C_{trip}) between pins 2 and 4. Please refer to [$t_{trip} - C_{trip}$ characteristics].

M57160AL-01

Hybrid IC for driving IGBT modules

ADJUSTMENT OF OUTPUT FALL TIME

(When the protection circuit is operating)

If the speed of reverse bias is decreased still more to reduce di/dt when the protection circuit operates, the resistor (62Ω, 1/8W) and capacitor (Cs) are connected in series between pin 6 and 9. Please adjust with the capacitance of Cs. (Please refer to under figures: fall time - Cs characteristics.)

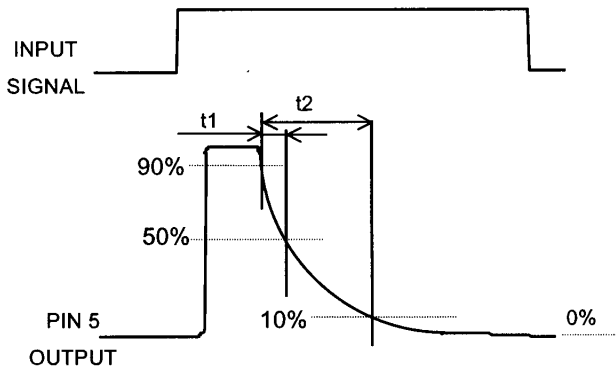

t1,t2 - Cs CHARACTERISTICS (TYPICAL)

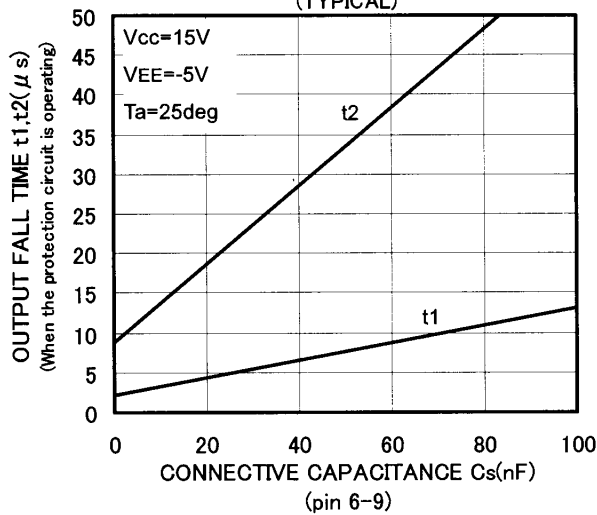

APPLICATION EXAMPLE OF ADJUSTMENT OF OUTPUT FALL TIME

(When the protection circuit is operating.)

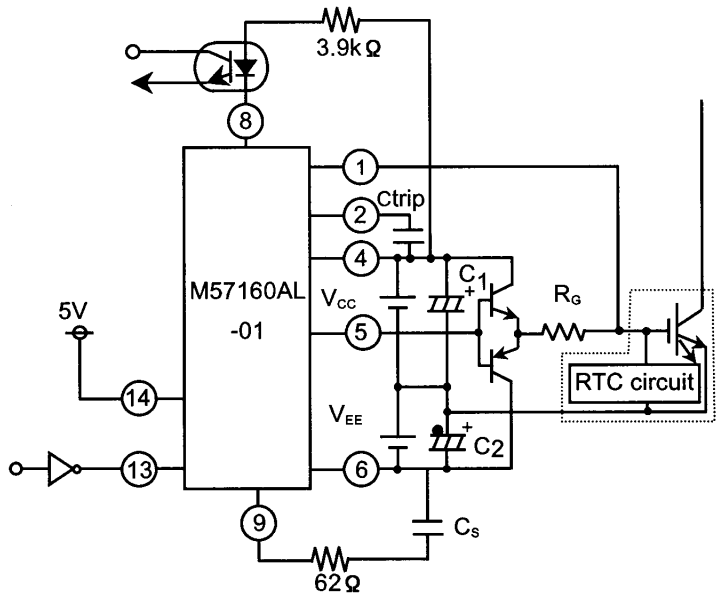

Vcc = 15V
VEE = -5V
Ctrip = 22pF
C1, C2 ≥ 100uF (low impedance)

PRACTICAL APPLICATION CIRCUIT

When the switching noise of gate drops over 2V for $5\ \mu\text{s}$ or more, this driver may operate the protection circuit. In this case, it needs the counterplan as the following figure.

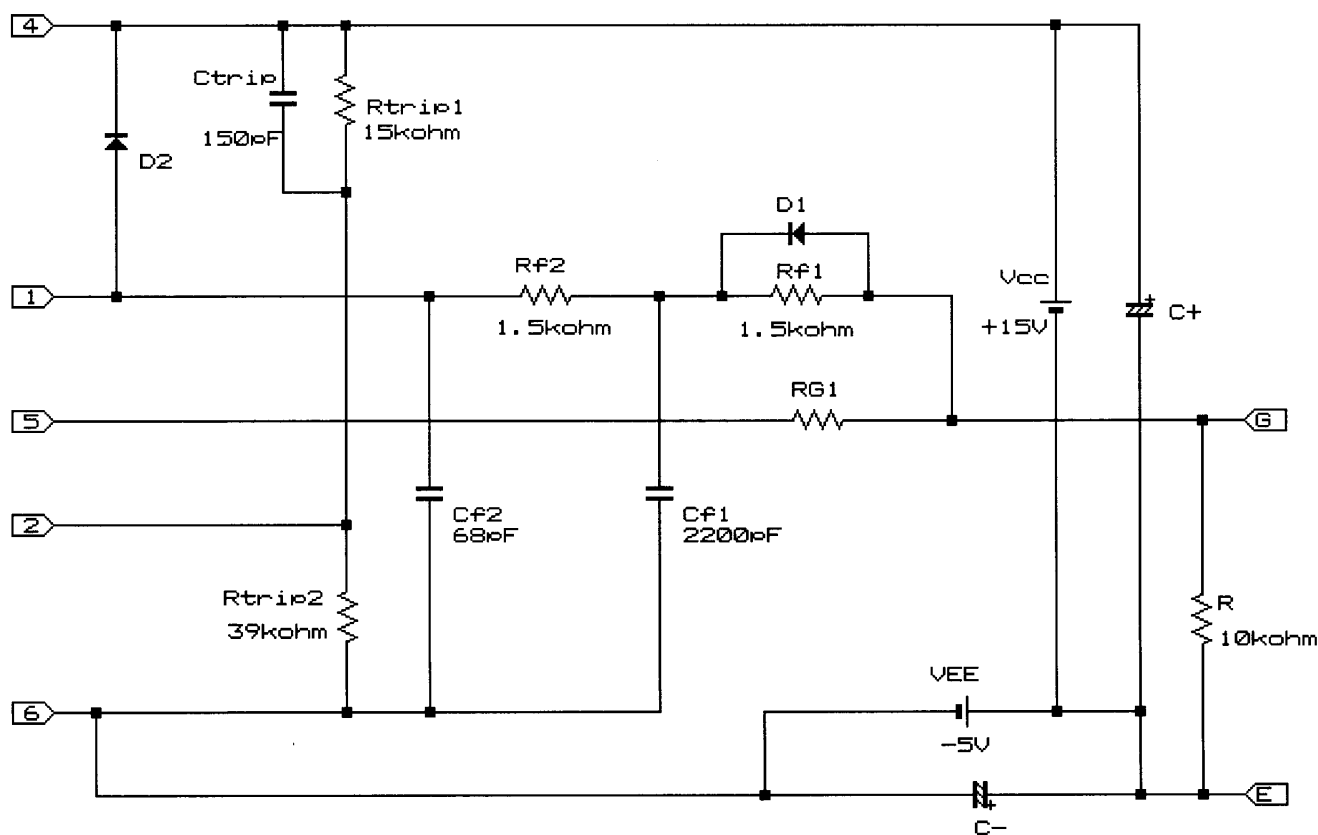

Rf1, Rf2, Cf1, Cf2, D1, D2: Parts for Noise filter circuits
 Rtrip1, Rtrip2: Parts for reduction of inner circuit's impedance

Please adjust circuit constants of each element by testing products to satisfy the following requirements.

- (1) The voltage between pin1 and pin6 is observed. And, the amplitude of the gate noise confirms 0.5V or less.
- (2) Please make sure whether IGBT can be intercepted within $10\ \mu\text{s}$ by the short-circuit test.

FOR SAFETY USING

Great detail and careful attention are given to the production activity of Hics, such as the development, the quality of production, and in its reliability. However the reliability of Hics depends not only on their own factors but also in their condition of usage. When handling Hics, please note the following cautions.

CAUTIONS	
Packing	<p>The materials used in packing Hics can only withstand normal external conditions. When exposed to outside shocks, rain and certain environmental contaminants, the packing materials will deteriorates. Please take care in handling.</p>
Carrying	<ol style="list-style-type: none"> 1) Don't stack boxes too high. Avoid placing heavy materials on boxes. 2) Boxes must be positioned correctly during transportation to avoid breakage. 3) Don't throw or drop boxes. 4) Keep boxes dry. Avoid rain or snow. 5) Minimal vibration and shock during transportation is desirable.
Storage	<p>When storing Hics, please observe the following notices or possible deterioration of their electrical characteristics, risk of solderability, and external damage may occur.</p> <ol style="list-style-type: none"> 1) Devices must be stored where fluctuation of temperature and humidity is minimal, and must not be exposed to direct sunlight. Store at the normal temperature of 5 to 30 degrees Celsius with humidity at 40 to 60%. 2) Avoid locations where corrosive gasses are generated or where much dust accumulates. 3) Storage cases must be static proof. 4) Avoid putting weight on boxes.
Extended storage	<p>When extended storage is necessary, Hics must be kept non-processed. When using Hics which have been stored for more than one year or under severe conditions, be sure to check that the exterior is free from flaw and other damages.</p>
Maximum ratings	<p>To prevent any electrical damages, use Hics within the maximum ratings. The temperaqtue, current, voltage, etc. must not exceed these conditions.</p>
Polarity	<p>To protect Hics from destruction and deterioration due to wrong insertion, make sure of polarity in inserting leads into the board holes, conforming to the external view for the terminal arrangement.</p>

ISAHAYA ELECTRONICS CORPORATION*Marketing division, Marketing planning department*

6-41 Tsukuba, Isahaya, Nagasaki, 854-0065 Japan

Keep safety first in your circuit designs!

- ISAHAYA Electronics Corporation puts the maximum effort into making semiconductor products better and more reliable, but there is always the possibility that trouble may occur with them. Trouble with semiconductors may lead to personal injury, fire or property damage. Remember to give due consideration to safety when making your circuit designs, with appropriate measures such as (1)placement of substitutive, auxiliary circuits, (2)use of non-flammable material or (3)prevention against any malfunction or mishap.

Notes regarding these materials

- These materials are intended as a reference to assist our customers in the selection of the ISAHAYA products best suited to the customer's application; they don't convey any license under any intellectual property rights, or any other rights, belonging ISAHAYA or a third party.
- ISAHAYA Electronics Corporation assumes no responsibility for any damage, or infringement of any third party's rights, originating in the use of any product data, diagrams, charts or circuit application examples contained in these materials.
- All information contained in these materials, including product data, diagrams and charts, represent information on products at the time of publication of these materials, and are subject to change by ISAHAYA Electronics Corporation without notice due to product improvements or other reasons. It is therefore recommended that customers contact ISAHAYA Electronics Corporation or an authorized ISAHAYA products distributor for the latest product information before purchasing product listed herein.
- ISAHAYA Electronics Corporation products are not designed or manufactured for use in a device or system that is used under circumstances in which human life is potentially at stake. Please contact ISAHAYA electronics corporation or an authorized ISAHAYA products distributor when considering the use of a product contained herein for any specific purposes, such as apparatus or systems for transportation, vehicular, medical, aerospace, nuclear, or undersea repeater use.
- The prior written approval of ISAHAYA Electronics Corporation is necessary to reprint or reproduce in whole or in part these materials.
- If these products or technologies are subject to the Japanese export control restrictions, they must be exported under a license from the Japanese government and cannot be imported into a country other than the approved destination. Any diversion or reexport contrary to the export control laws and regulations of Japan and/or the country of destination is prohibited.
- Please contact ISAHAYA Electronics Corporation or an authorized ISAHAYA products distributor for further details on these materials or the products contained therein.