



TIN CAN AVALANCHE AUTOMOTIVE RECTIFIER

TRA40M

AVALANCHE VOLTAGE 37 to 41 Volts
CURRENT 40 Amperes

Technical Specifecation:

Features:

- High power capability
- Economical
- Avalanche Voltage: 37V to 41V
- Glass passivated chip

MECHANICAL DATA

- Case: Tin Can
- Epoxy: UL94-0 rate flame ratardant
- Polarity: the glass is blue (Positive)
the glass is white (Negative)
- Technology vacuum soldered
- Lead: Plated slug, solderable per MIL-STD-202E Method 208C
- Weight: 0.09 ounce, 2.57 Grams

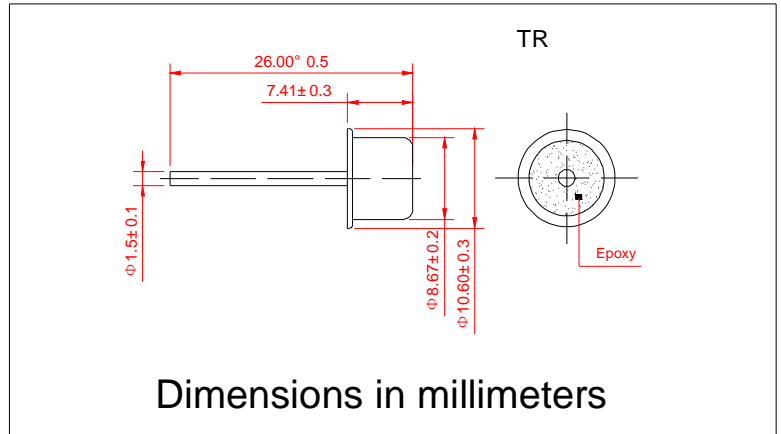

MAXIMUM RATINGS AND ELECTRICAL CHARACTERISTICS

- Ratings at 25°C ambient temperature unless otherwise specified
- Single Phase, half wave, 60Hz, resistive or inductive load
- For capacitive load derate current by 20%

Electrical Characteristics @ 25°C	SYMBOLS	MIN	NOMINAL	MAX	UNITS
Peak Repetitive Reverse Voltage	V _{RRM}		28		Volts
Working Peak Reverse Voltage	V _{RRM}		28		
DC Blocking Voltage	V _{DC}		28		
Average Rectified Forward Current (T _c =125°C)	I _o		40		Amps
Repetitive Peak Reverse Surge Current T _c =10msec Dury Cycle<1%	I _{RSM}		40		Amps
Breakdown Voltage (V _{br} @ir=100mA, T _c =25°C) Ir=90Amps, T _c =150°C, PW=80usec	V _{br1}	37	39	41	Volts
	V _{br2}			54	Volts
Forward Voltage Drop @If=100Amps<300usec	V _F		1.02	1.05	Volts
Peak Forward Surge Current	I _{FSM}		500		Amps
Reverse Leakage (V _R =17Vdc) T _A =25°C	I _R		1.0	2.0	uAmps
Operating and Storage Junction Temperature Range	T _J , T _{STG}		-65 to +175		°C

Notes: 1. Enough heatsink must be considered in application.

