



<b>FREQUENCY STABILITY</b>	
OVER:	
OPERATING TEMP. RANGE:	See note 1
OVERALL STABILITY:	$< \pm 100\text{ppm}^*$
INCLUDING:	
<ul style="list-style-type: none"> <li>OVER OPERATING TEMPERATURE RANGE</li> <li>ADJUSTMENT @ 25°C</li> <li>LONG TERM AGING (10 YEARS)</li> <li>STABILITY OVER SUPPLY VOLTAGE <math>\pm 10\%</math></li> <li>STABILITY OVER LOAD (MIN. TO MAX.)</li> </ul>	
<b>POWER SUPPLY</b>	
SUPPLY VOLTAGE:	$V_{dd} = 5V \pm 10\%^*$
INPUT CURRENT:	$< 15\text{mA}^*$
<b>OUTPUT</b>	
OUTPUT SIGNAL:	HC-MOS compatible *
SYMMETRY:	40 / 60% (min.) @ $V_{dd} / 2^*$
RISE & FALL TIME:	$t_r < 7\text{ns}$ $t_f < 7\text{ns}^*$
LEVEL "0" & "1":	$< 0.4V$ $> V_{dd} - 0.5V$
START-UP TIME:	$< 5\text{ms}$
FAN OUT (LOAD):	10 TTL / LS *
<b>ENVIRONMENT</b>	
OPERABLE TEMP. RANGE:	-55 to +125°C
STORAGE TEMP. RANGE:	-65 to +125°C
VIBRATIONS:	10 to 2000Hz / 10g
SHOCKS:	5000g, 0.3ms, 1/2 sine
PACKAGE:	Ceramic
PACKAGE DIMENSIONS:	14.1 x 9.3 x 2.4mm (see packaging info)
PROCESSING:	Reflow soldering 260°C / 10s max. (see packaging info)
<b>MISCELLANEOUS</b>	
* Customer's specification on request	

<b>Note 1: Operating Temperature Range</b>	
MCSO-A:	0 to +70 °C
MCSO-B:	-40 to +85 °C
MCSO-C:	-55 to +125 °C

<b>Option 1: Enable / Disable (on request)</b>	
See application circuit on page 2 for details	
<b>Pin 1:</b>	<b>Pin 3 (Foot):</b>
Open	Clock
H	Clock
L	High Z
Not available for $f < 500\text{kHz}$	

<b>Option 2: J / Leads (on request)</b>
With tinned J / Leads pins Height: 3.8mm included J / Leads

<b>Marking Example</b>			
			
MCSO-B	E/D	Type	Option 1
20.000 MHz	05.44	Frequency	Date Code
○		○ (PIN 1)	

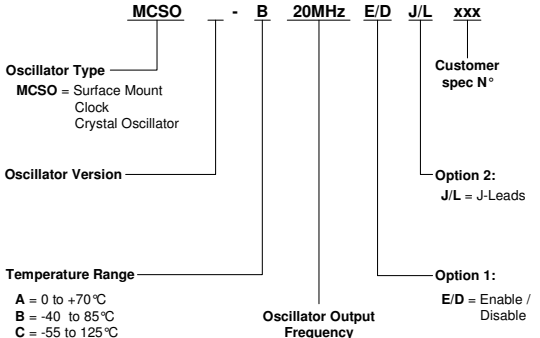
<b>Ordering Information Example</b>			
			
<b>Oscillator Type</b> MCSO = Surface Mount Clock Crystal Oscillator		<b>Customer spec N*</b>	
<b>Oscillator Version</b>		<b>Option 2:</b> J/L = J-Leads	
<b>Temperature Range</b> A = 0 to +70°C B = -40 to 85°C C = -55 to 125°C X = Custom spec.		<b>Option 1:</b> E/D = Enable / Disable	

<b>STANDARD FREQUENCIES [MHz]</b>						
10.0000	10.1500	10.2300	10.2400	11.0592	12.0000	
12.2880	12.8000	13.0000	14.7456	16.0000	16.3840	
18.4320	19.2000	19.6608	20.0000			& sub multiple

Date :	June 2003	Revision No. :	7	Revision Date :	11-05
--------	-----------	----------------	---	-----------------	-------

In accordance with our policy of continuous development and improvement, we reserve the right to modify the design or the specifications of our products without prior notice.

Headquarters:	Micro Crystal	Tel.	+41 32 655 82 82
	Div. of ETA SA	Fax	+41 32 655 80 90
	Mühlestrasse 14	Internet	www.microcrystal.ch
	CH-2540 Grenchen	Email	sales@microcrystal.ch
	Switzerland		

**Application and Test Circuit:**

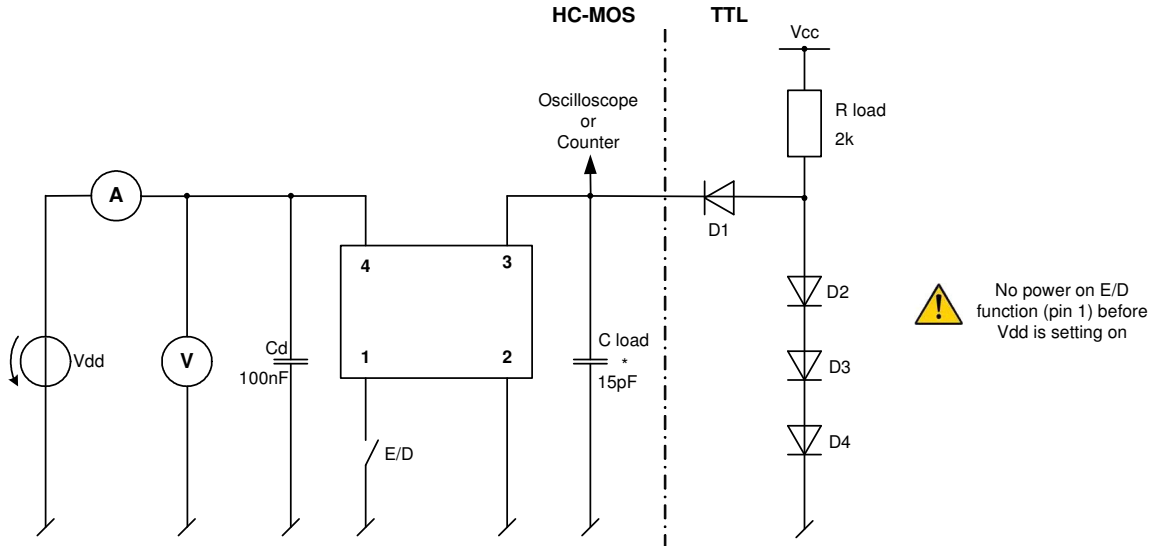

**Waveform Output:**

**Waveshape TTL**

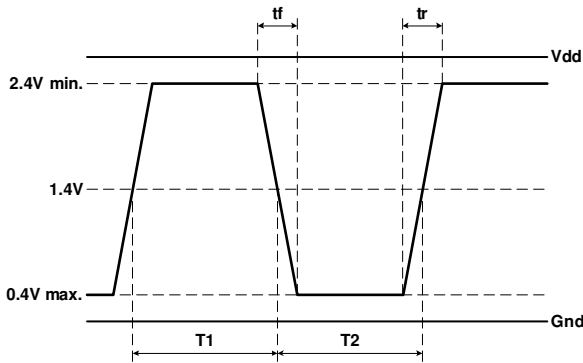

**Waveshape HC-MOS**

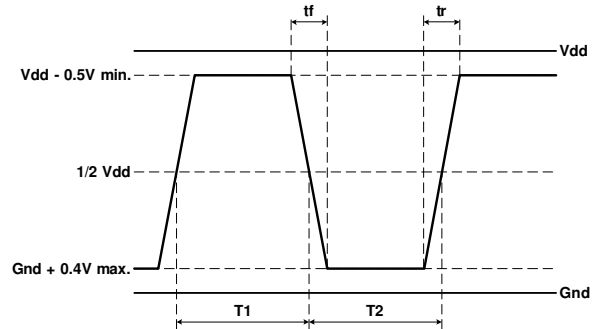

$$Duty\ Cycle = 100 \times \frac{T1}{T1 + T2} [\%]$$

Date :	June 2003	Revision No. :	7	Revision Date :	11-05
--------	-----------	----------------	---	-----------------	-------

In accordance with our policy of continuous development and improvement, we reserve the right to modify the design or the specifications of our products without prior notice.

Headquarters: Micro Crystal  
Div. of ETA SA  
Mühlestrasse 14  
CH-2540 Grenchen  
Switzerland

Tel. +41 32 655 82 82  
Fax +41 32 655 80 90  
Internet [www.microcrystal.ch](http://www.microcrystal.ch)  
Email [sales@microcrystal.ch](mailto:sales@microcrystal.ch)