

Timing-Safe™ Peak EMI reduction IC

General Features

- Clock distribution with Timing-Safe™ Peak EMI Reduction
- Input frequency range: 20MHz - 50MHz
- Multiple low skew Timing-safe™ Outputs:
PCS3P623Z05: 5 Outputs
PCS3P623Z09: 9 Outputs
- External Input-Output Delay Control option
- Supply Voltage: 3.3V±0.3V
- Commercial and Industrial temperature range
- Packaging Information:
ASM3P623Z05: 8 pin SOIC, and TSSOP
ASM3P623Z09: 16 pin SOIC, and TSSOP
- True Drop-in Solution for Zero Delay Buffer,
ASM5P2305A / 09A

Functional Description

PCS3P623Z05/09 is a versatile, 3.3V Zero-delay buffer

designed to distribute Timing-Safe™ clocks with Peak EMI reduction. PCS3P623Z05 is an eight-pin version, accepts one reference input and drives out five low-skew Timing-Safe™ clocks. PCS3P623Z09 accepts one reference input and drives out nine low-skew Timing-Safe™ clocks.

PCS3P623Z05/09 has a DLY_CTRL for adjusting the Input-Output clock delay, depending upon the value of capacitor connected at this pin to GND.

PCS3P623Z05/09 operates from a 3.3V supply and is available in two different packages, as shown in the ordering information table, over commercial and Industrial temperature range.

Application

PCS3P623Z05/09 is targeted for use in Displays and memory interface systems.

General Block Diagram

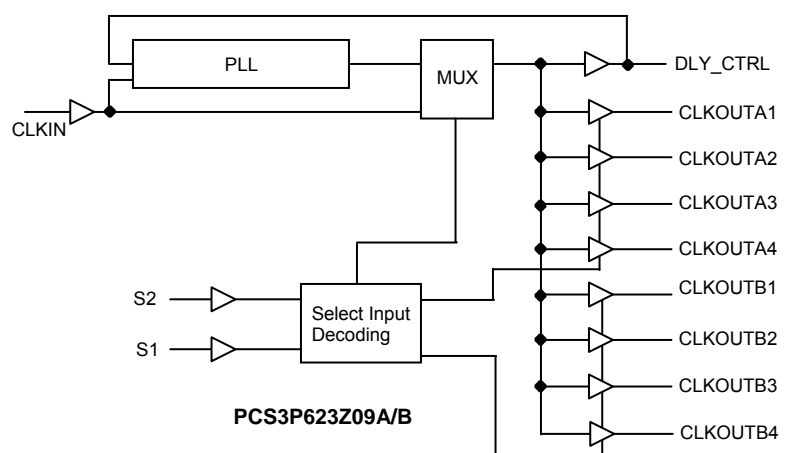
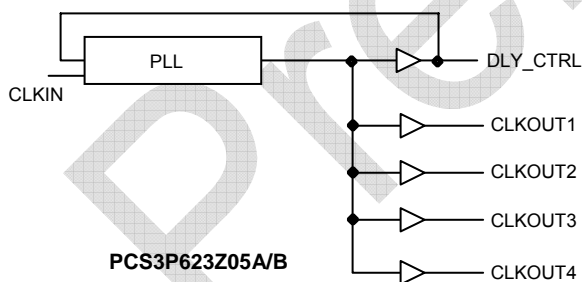

May 2008

rev 0.1

Spread Spectrum Frequency Generation

The clocks in digital systems are typically square waves with a 50% duty cycle and as frequencies increase the edge rates also get faster. Analysis shows that a square wave is composed of fundamental frequency and harmonics. The fundamental frequency and harmonics generate the energy peaks that become the source of EMI. Regulatory agencies test electronic equipment by measuring the amount of peak energy radiated from the equipment. In fact, the peak level allowed decreases as the frequency increases. The standard methods of reducing EMI are to use shielding, filtering, multi-layer

PCBs etc. These methods are expensive. Spread spectrum clocking reduces the peak energy by reducing the Q factor of the clock. This is done by slowly modulating the clock frequency. The PCS3P623Z05/09 uses the center modulation spread spectrum technique in which the modulated output frequency varies above and below the reference frequency with a specified modulation rate. With center modulation, the average frequency is the same as the unmodulated frequency and there is no performance degradation

Zero Delay and Skew Control

All outputs should be uniformly loaded to achieve Zero Delay between input and output. Since the DLY_CTRL pin is the internal feedback to the PLL, its relative loading can adjust the input-output delay.

For applications requiring zero input-output delay, all outputs, including DLY_CTRL, must be equally loaded. Even if DLY_CTRL is not used, it must have a capacitive load equal to that on other outputs, for obtaining zero-input-output delay.

Timing-Safe™ technology

Timing-Safe™ technology is the ability to modulate a clock source with Spread Spectrum technology and maintain synchronization with any associated data path.

May 2008

rev 0.1

Pin Configuration for PCS3P623Z05A/B

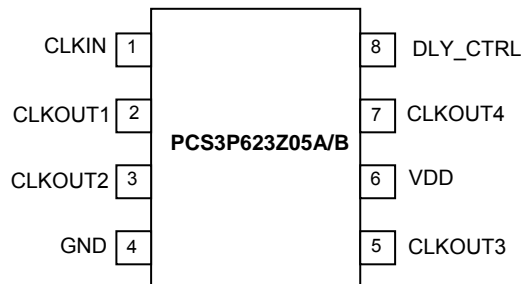

Pin Description for PCS3P623Z05A/B

Pin #	Pin Name	Type	Description
1	CLKIN ¹	I	External reference Clock input, 5V tolerant input
2	CLKOUT1 ²	O	Buffered clock output ⁴
3	CLKOUT2 ²	O	Buffered clock output ⁴
4	GND	P	Ground
5	CLKOUT3 ²	O	Buffered clock output ⁴
6	VDD	P	3.3V supply
7	CLKOUT4 ²	O	Buffered clock output ⁴
8	DLY_CTRL	O	External Input-Output Delay control. This pin can be used as clock output ⁴

May 2008

rev 0.1

Pin Configuration for PCS3P623Z09A/B

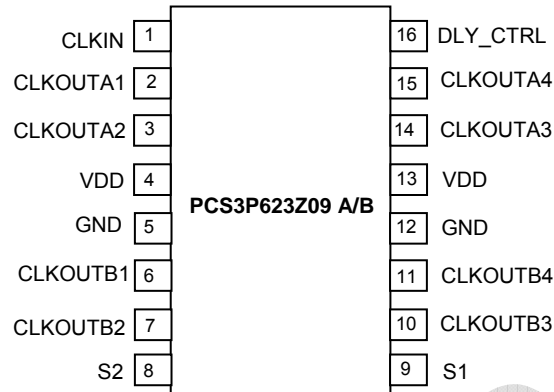

Pin Description for PCS3P623Z09A/B

Pin #	Pin Name	Pin Type	Description
1	CLKIN ¹	I	External reference Clock input, 5V tolerant input
2	CLKOUTA1 ²	O	Buffered clock Bank A output ⁴
3	CLKOUTA2 ²	O	Buffered clock Bank A output ⁴
4	VDD	P	3.3V supply
5	GND	P	Ground
6	CLKOUTB1 ²	O	Buffered clock Bank B output ⁴
7	CLKOUTB2 ²	O	Buffered clock Bank B output ⁴
8	S2 ³	I	Select input, bit 2. See <i>Select Input Decoding table for PCS3P623Z09</i> for more details
9	S1 ³	I	Select input, bit 1. See <i>Select Input Decoding table for PCS3P623Z09</i> for more details
10	CLKOUTB3 ²	O	Buffered clock Bank B output ⁴
11	CLKOUTB4 ²	O	Buffered clock Bank B output ⁴
12	GND	P	Ground
13	VDD	P	3.3V supply
14	CLKOUTA3 ²	O	Buffered clock Bank A output ⁴
15	CLKOUTA4 ²	O	Buffered clock Bank A output ⁴
16	DLY_CTRL ²	O	External Input-Output Delay control. This pin can be used as clock output

Notes: 1. Weak pull down
2. Weak pull-down on all outputs
3. Weak pull-up on these Inputs
4. Buffered clock output is Timing-Safe™

May 2008

rev 0.1

Select Input Decoding table for PCS3P623Z09

S2	S1	CLKOUT A1 - A4	CLKOUT B1 - B4	DLY_CTRL ¹	Output Source	PLL Shut-Down
0	0	Three-state	Three-state	Driven	PLL	N
0	1	Driven	Three-state	Driven	PLL	N
1	0	Driven	Driven	Driven	Reference	Y
1	1	Driven	Driven	Driven	PLL	N

Notes: This output is driven and has an internal feedback for the PLL. The load on this output can be adjusted to change the skew between the reference and the Output

Spread Spectrum Control and Input-Output Skew Table

Frequency (MHz)	Device	Deviation ($\pm\%$)	Input-Output Skew ($\pm T_{SKEW}$)
32	PCS3P623Z05A / 09A	0.125	0.125
	PCS3P623Z05B / 09B	0.25	0.25

Note: T_{SKEW} is measured in units of the Clock Period

Absolute Maximum Ratings

Symbol	Parameter	Rating	Unit
VDD	Supply Voltage to Ground Potential	-0.5 to +4.6	V
VIN	DC Input Voltage (CLKIN)	-0.5 to +7	
T_{STG}	Storage temperature	-65 to +125	°C
T_s	Max. Soldering Temperature (10 sec)	260	°C
T_J	Junction Temperature	150	°C
T_{DV}	Static Discharge Voltage (As per JEDEC STD22- A114-B)	2	KV

Note: These are stress ratings only and are not implied for functional use. Exposure to absolute maximum ratings for prolonged periods of time may affect device reliability.

Operating Conditions

Parameter	Description	Min	Max	Unit
VDD	Supply Voltage	3.0	3.6	V
T_A	Operating Temperature (Ambient Temperature)	-40	+85	°C
C_L	Load Capacitance		30	pF
C_{IN}	Input Capacitance		7	pF

May 2008

rev 0.1

Electrical Characteristics

Parameter	Description	Test Conditions	Min	Typ	Max	Unit
V _{IL}	Input LOW Voltage ⁵				0.8	V
V _{IH}	Input HIGH Voltage ⁵		2.0			V
I _{IL}	Input LOW Current	V _{IN} = 0V			50	μA
I _{IH}	Input HIGH Current	V _{IN} = VDD			100	μA
V _{OL}	Output LOW Voltage ⁶	I _{OL} = 8mA			0.4	V
V _{OH}	Output HIGH Voltage ⁶	I _{OH} = -8mA	2.4			V
I _{DD}	Supply Current	Unloaded outputs			27	mA
Z _o	Output Impedance			23		Ω

Note: 5. CLKIN input has a threshold voltage of VDD/2

6. Parameter is guaranteed by design and characterization. Not 100% tested in production

Switching Characteristics

Parameter	Test Conditions	Min	Typ	Max	Unit
Input Frequency		20		50	MHz
Output Frequency	30pF load	20		50	MHz
Duty Cycle ^{7,8} = (t ₂ / t ₁) * 100	Measured at VDD/2	40	50	60	%
Output Rise Time ^{7,8}	Measured between 0.8V and 2.0V			2.5	nS
Output Fall Time ^{7,8}	Measured between 2.0V and 0.8V			2.5	nS
Output-to-output skew ^{7,8}	All outputs equally loaded			250	pS
Delay, CLKIN Rising Edge to CLKOUT Rising Edge ⁸	Measured at VDD /2			±350	pS
Device-to-Device Skew ⁸	Measured at VDD/2 on the CLKOUT pins of the device			700	pS
Cycle-to-Cycle Jitter ^{7,8}	Loaded outputs			±250	pS
PLL Lock Time ⁸	Stable power supply, valid clock presented on CLKIN pin			1.0	mS

Note: 7. All parameters specified with 30pF loaded outputs.

8. Parameter is guaranteed by design and characterization. Not 100% tested in production

May 2008

rev 0.1

Switching Waveforms

Duty Cycle Timing

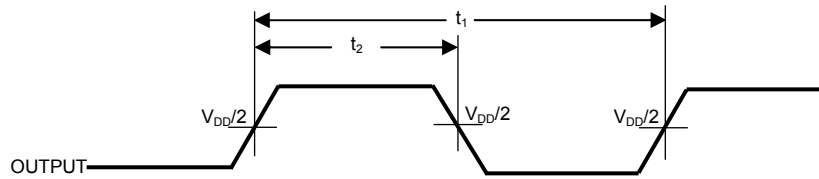

All Outputs Rise/Fall Time

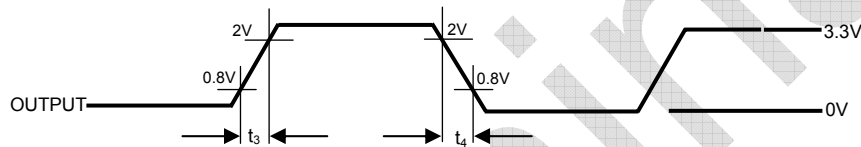

Output - Output Skew

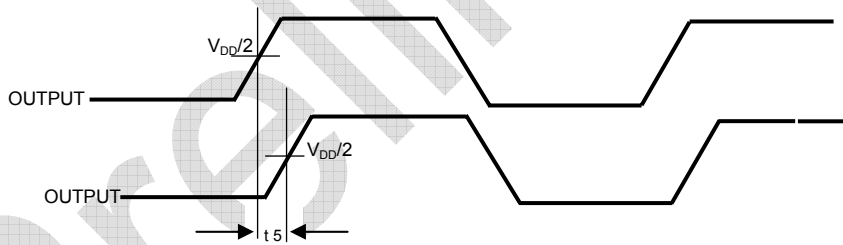

Input - Output Propagation Delay

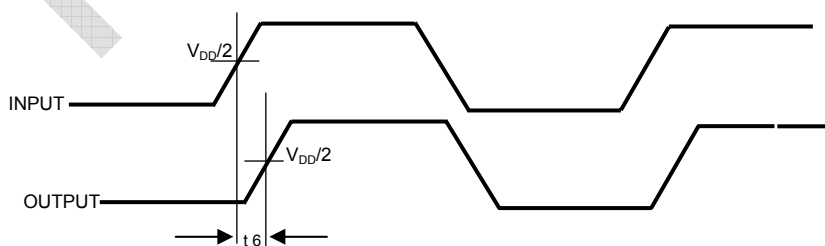

May 2008

rev 0.1

Device - Device Skew

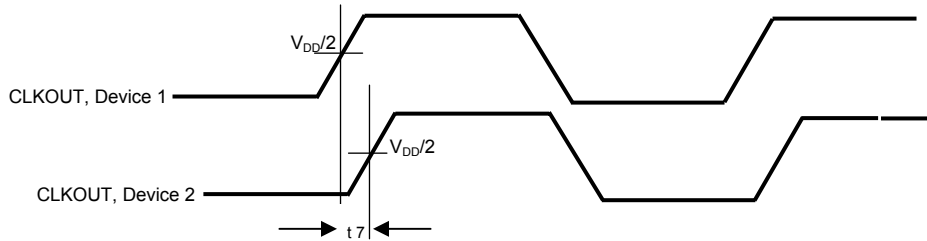

Input-Output Skew

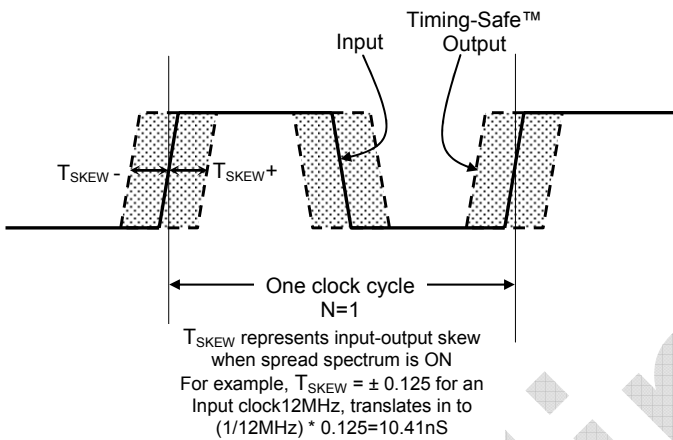

Test Circuit

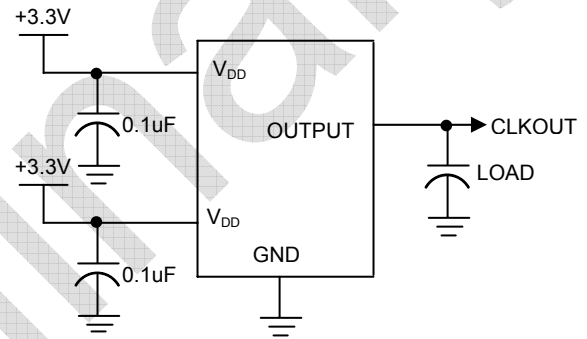

A Typical example of Timing-Safe™ waveform

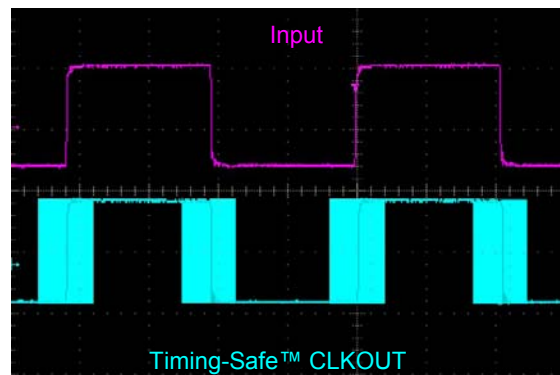
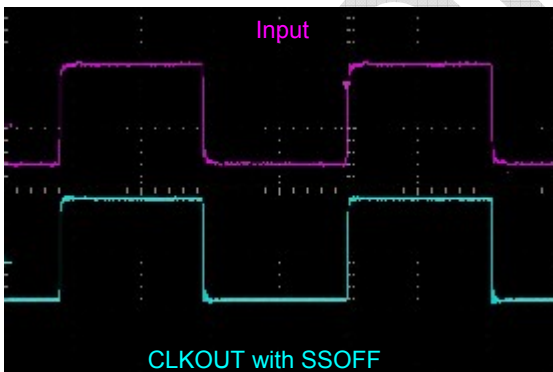

May 2008

rev 0.1

Package Information

8-lead (150-mil) SOIC Package

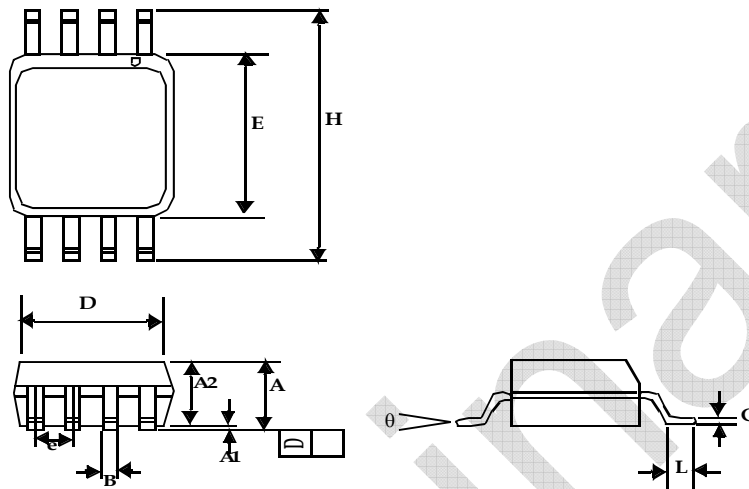

Symbol	Dimensions			
	Inches		Millimeters	
	Min	Max	Min	Max
A1	0.004	0.010	0.10	0.25
A	0.053	0.069	1.35	1.75
A2	0.049	0.059	1.25	1.50
B	0.012	0.020	0.31	0.51
C	0.007	0.010	0.18	0.25
D	0.193 BSC		4.90 BSC	
E	0.154 BSC		3.91 BSC	
e	0.050 BSC		1.27 BSC	
H	0.236 BSC		6.00 BSC	
L	0.016	0.050	0.41	1.27
θ	0°	8°	0°	8°

8-lead TSSOP (4.40-MM Body)

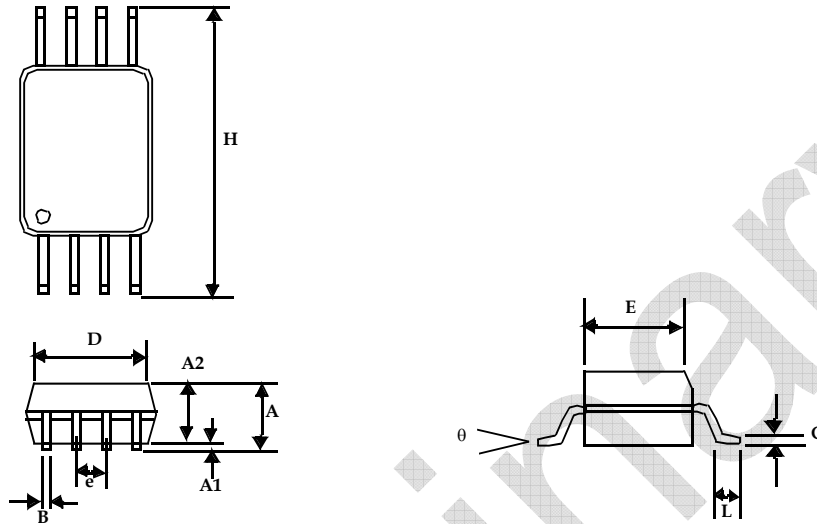

Symbol	Dimensions			
	Inches		Millimeters	
	Min	Max	Min	Max
A		0.043		1.10
A1	0.002	0.006	0.05	0.15
A2	0.033	0.037	0.85	0.95
B	0.008	0.012	0.19	0.30
c	0.004	0.008	0.09	0.20
D	0.114	0.122	2.90	3.10
E	0.169	0.177	4.30	4.50
e	0.026 BSC		0.65 BSC	
H	0.252 BSC		6.40 BSC	
L	0.020	0.028	0.50	0.70
θ	0°	8°	0°	8°

16-lead (150 Mil) Molded SOIC Package

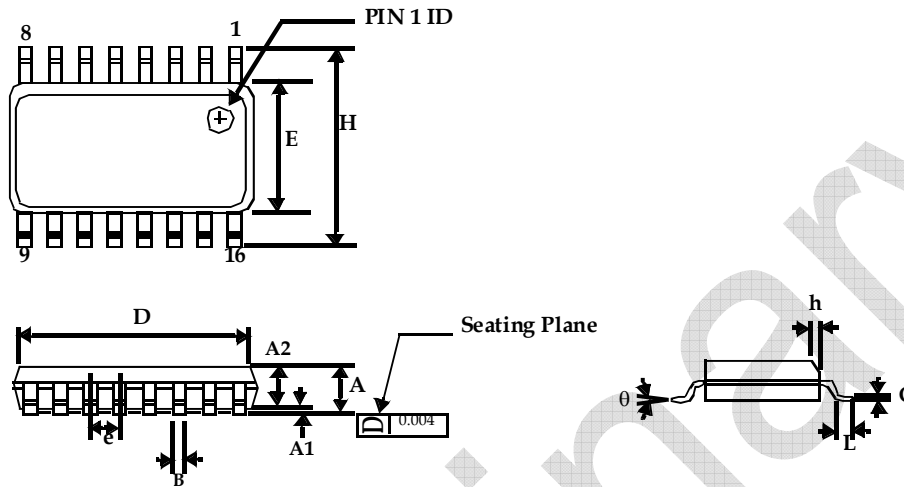

Symbol	Dimensions			
	Inches		Millimeters	
	Min	Max	Min	Max
A	0.053	0.069	1.35	1.75
A1	0.004	0.010	0.10	0.25
A2	0.049	0.059	1.25	1.50
B	0.013	0.022	0.33	0.53
C	0.008	0.012	0.19	0.27
D	0.386	0.394	9.80	10.01
E	0.150	0.157	3.80	4.00
e	0.050 BSC		1.27 BSC	
H	0.228	0.244	5.80	6.20
h	0.010	0.016	0.25	0.41
L	0.016	0.035	0.40	0.89
θ	0°	8°	0°	8°

16-lead TSSOP (4.40-MM Body)

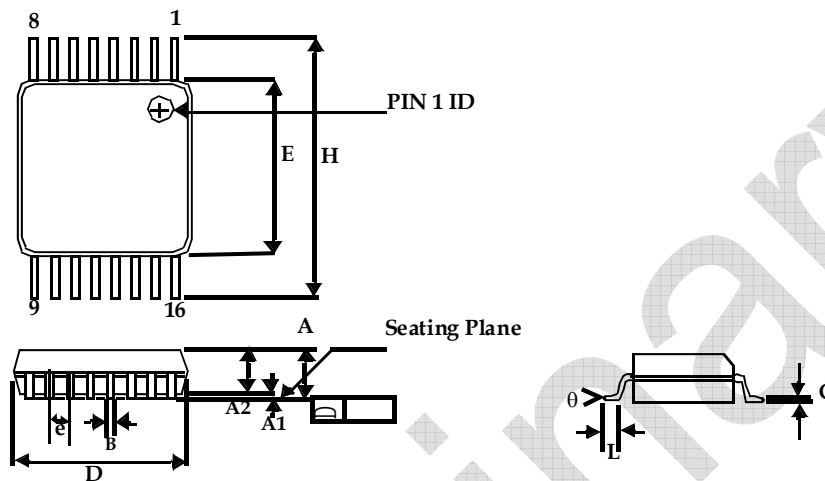

Symbol	Dimensions			
	Inches		Millimeters	
	Min	Max	Min	Max
A		0.043		1.20
A1	0.002	0.006	0.05	0.15
A2	0.031	0.041	0.80	1.05
B	0.007	0.012	0.19	0.30
C	0.004	0.008	0.09	0.20
D	0.193	0.201	4.90	5.10
E	0.169	0.177	4.30	4.50
e	0.026 BSC		0.65 BSC	
H	0.252 BSC		6.40 BSC	
L	0.020	0.030	0.50	0.75
θ	0°	8°	0°	8°

May 2008

rev 0.1

Ordering Code

Ordering Code	Marking	Package Type	Temperature
PCS3P623Z0xyG-08-ST	3P623Z0xyG	8-pin 150-mil SOIC-TUBE, Green	Commercial
PCS3I623Z0xyG-08-ST	3I623Z0xyG	8-pin 150-mil SOIC-TUBE, Green	Industrial
PCS3P623Z0xyG-08-SR	3P623Z0xyG	8-pin 150-mil SOIC-TAPE & REEL, Green	Commercial
PCS3I623Z0xyG -08-SR	3I623Z0xyG	8-pin 150-mil SOIC-TAPE & REEL, Green	Industrial
PCS3P623Z0xyG-08-TT	3P623Z0xyG	8-pin 4.4-mm TSSOP - TUBE, Green	Commercial
PCS3I623Z00xyG -08-TT	3I623Z0xyG	8-pin 4.4-mm TSSOP - TUBE, Green	Industrial
PCS3P623Z0xyG-08-TR	3P623Z0xyG	8-pin 4.4-mm TSSOP - TAPE & REEL, Green	Commercial
PCS3I623Z0xyG -08-TR	3I623Z0xyG	8-pin 4.4-mm TSSOP - TAPE & REEL, Green	Industrial
PCS3P623Z0xyG -16-ST	3P623Z0xyG	16-pin 150-mil SOIC-TUBE, Green	Commercial
PCS3I623Z0xyG -16-ST	3I623Z0xyG	16-pin 150-mil SOIC-TUBE, Green	Industrial
PCS3P623Z0xyG -16-SR	3P623Z0xyG	16-pin 150-mil SOIC-TAPE & REEL, Green	Commercial
PCS3I623Z0xyG -16-SR	3I623Z0xyG	16-pin 150-mil SOIC-TAPE & REEL, Green	Industrial
PCS3P623Z0xyG -16-TT	3P623Z0xyG	16-pin 4.4-mm TSSOP - TUBE, Green	Commercial
PCS3I623Z0xyG -16-TT	3I623Z0xyG	16-pin 4.4-mm TSSOP - TUBE, Green	Industrial
PCS3P623Z0xyG -16-TR	3P623Z0xyG	16-pin 4.4-mm TSSOP - TAPE & REEL, Green	Commercial
PCS3I623Z0xyG -16-TR	3I623Z0xyG	16-pin 4.4-mm TSSOP - TAPE & REEL, Green	Industrial

Note: x=5 / 9; y=A / B

Device Ordering Information

P C S 3 P 6 2 3 Z 0 x y G - 0 8 - T R

R = Tape & Reel, T = Tube or Tray		
O = TSOT23 S = SOIC T = TSSOP A = SSOP V = TVSOP B = BGA O = OFN	U = MSOP E = TQFP L = LQFP U = MSOP P = PDIP D = QSOP X = SC-70	J=TSOT26 C=TDFN (2X2) COL
DEVICE PIN COUNT		
F = LEAD FREE AND RoHS COMPLIANT PART G = GREEN PACKAGE, LEAD FREE, and RoHS		
PART NUMBER		
X = Automotive (-40C to +125C)	I = Industrial (-40C to +85C)	P or n/c = Commercial (0C to +70C)
1 = Clock Generator 2 = Non PLL based 3 = EMI Reduction 4 = DDR support products 5 = STD Zero Delay Buffer	6 = Power Management 7 = Power Management 8 = Power Management 9 = Hi Performance 0 = Reserved	
PulseCore Semiconductor Mixed Signal Product		

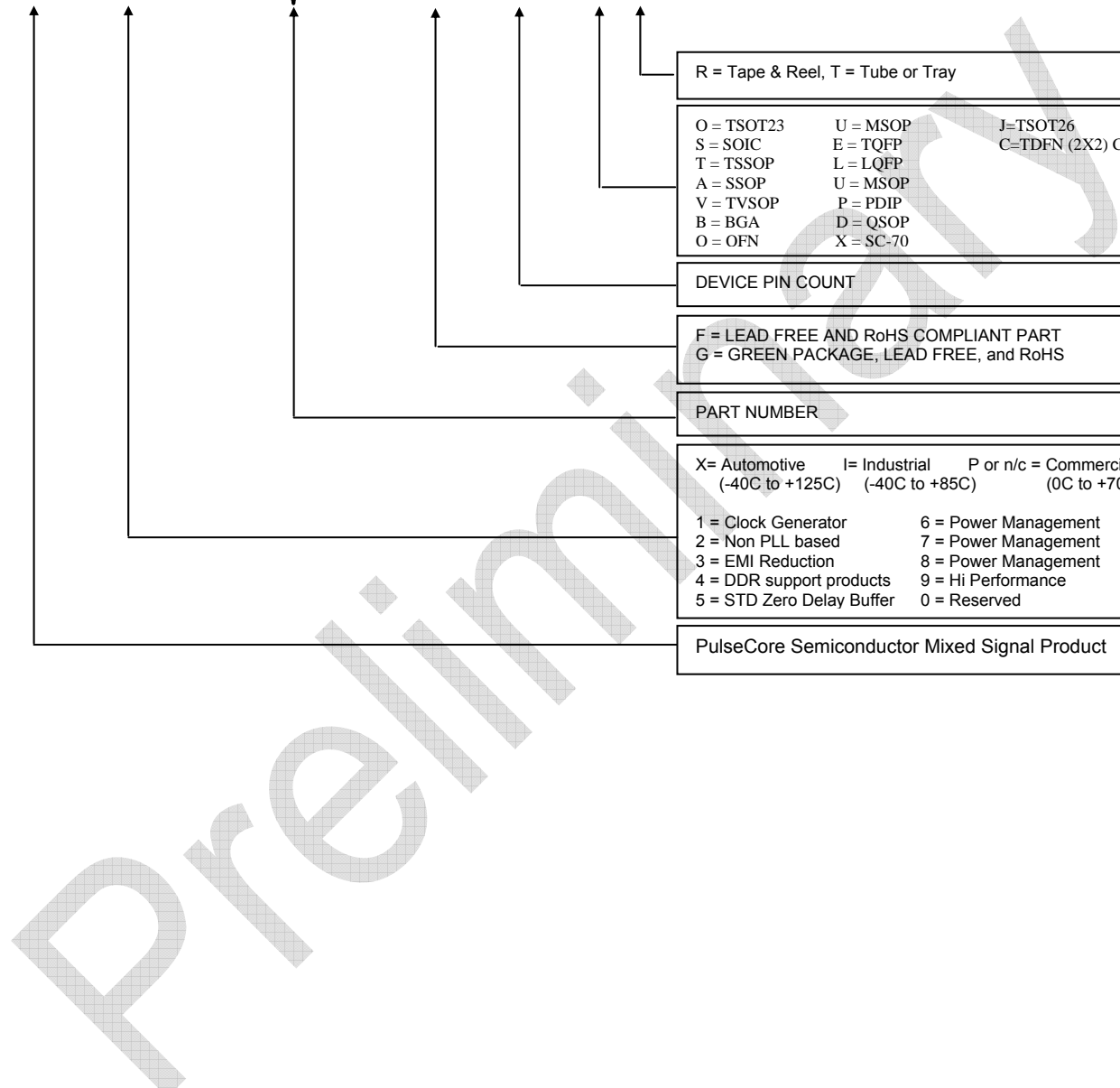



PulseCore Semiconductor Corporation
1715 S. Bascom Ave Suite 200
Campbell, CA 95008
Tel: 408-879-9077
Fax: 408-879-9018
www.pulsecoresemi.com

Copyright © PulseCore Semiconductor
All Rights Reserved
Part Number: PCS3P623Z05A/B
PCS3P623Z09A/B
Document Version: 0.1

Note: This product utilizes US Patent # 6,646,463 Impedance Emulator Patent issued to PulseCore Semiconductor, dated 11-11-2003
Many PulseCore Semiconductor products are protected by issued patents or by applications for patent

© Copyright 2006 PulseCore Semiconductor Corporation. All rights reserved. Our logo and name are trademarks or registered trademarks of PulseCore Semiconductor. All other brand and product names may be the trademarks of their respective companies. PulseCore reserves the right to make changes to this document and its products at any time without notice. PulseCore assumes no responsibility for any errors that may appear in this document. The data contained herein represents PulseCore's best data and/or estimates at the time of issuance. PulseCore reserves the right to change or correct this data at any time, without notice. If the product described herein is under development, significant changes to these specifications are possible. The information in this product data sheet is intended to be general descriptive information for potential customers and users, and is not intended to operate as, or provide, any guarantee or warranty to any user or customer. PulseCore does not assume any responsibility or liability arising out of the application or use of any product described herein, and disclaims any express or implied warranties related to the sale and/or use of PulseCore products including liability or warranties related to fitness for a particular purpose, merchantability, or infringement of any intellectual property rights, except as express agreed to in PulseCore's Terms and Conditions of Sale (which are available from PulseCore). All sales of PulseCore products are made exclusively according to PulseCore's Terms and Conditions of Sale. The purchase of products from PulseCore does not convey a license under any patent rights, copyrights; mask works rights, trademarks, or any other intellectual property rights of PulseCore or third parties. PulseCore does not authorize its products for use as critical components in life-supporting systems where a malfunction or failure may reasonably be expected to result in significant injury to the user, and the inclusion of PulseCore products in such life-supporting systems implies that the manufacturer assumes all risk of such use and agrees to indemnify PulseCore against all claims arising from such use.