

## AS85049/62 and M38999/2 Shrink Boot Adapters

### Glenair Connector Designator F

MIL-DTL-38999 Series I &  
II, 40M38277, PAN 6433-1,  
PATT 614, PATT 616,  
NFC93422 Series HE308 &  
HE309

### M85049/62-10 W D

Basic Part No. \_\_\_\_\_ Drain Hole Option (Omit for none)  
Shell Size \_\_\_\_\_ Finish  
A = Anodize Black  
N = Electroless Nickel  
W = 1,000 Hr. Cadmium Olive Drab  
Over Electroless Nickel

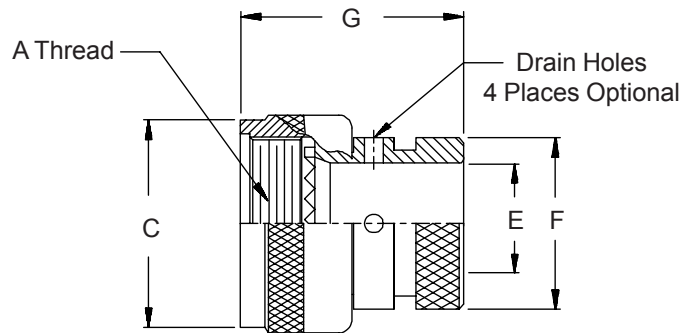

### TABLE I

| Shell<br>Size | A Thread<br>Class 2B | C Dia           |                | E Dia<br>Min | F Dia<br>Min | G     |        |
|---------------|----------------------|-----------------|----------------|--------------|--------------|-------|--------|
|               |                      | + .000<br>-.062 | (0.0)<br>(1.6) |              |              | Max   | Max    |
| 08            | .438 - 28 UNEF       | .567            | (14.4)         | .250 (6.4)   | .533 (13.5)  | 1.000 | (25.4) |
| 10            | .562 - 24 UNEF       | .704            | (17.9)         | .375 (9.5)   | .605 (15.4)  | 1.000 | (25.4) |
| 12            | .688 - 24 UNEF       | .829            | (21.1)         | .500 (12.7)  | .774 (19.7)  | 1.000 | (25.4) |
| 14            | .813 - 20 UNEF       | .954            | (24.2)         | .625 (15.9)  | .838 (21.3)  | 1.000 | (25.4) |
| 16            | .938 - 20 UNEF       | 1.079           | (27.4)         | .750 (19.1)  | .963 (24.5)  | 1.000 | (25.4) |
| 18            | 1.063 - 18 UNEF      | 1.203           | (30.6)         | .812 (20.6)  | 1.042 (26.5) | 1.000 | (25.4) |
| 20            | 1.188 - 18 UNEF      | 1.329           | (33.8)         | .937 (23.8)  | 1.217 (30.9) | 1.000 | (25.4) |
| 22            | 1.313 - 18 UNEF      | 1.454           | (36.9)         | 1.062 (27.0) | 1.355 (34.4) | 1.000 | (25.4) |
| 24            | 1.438 - 18 UNEF      | 1.579           | (40.1)         | 1.188 (30.2) | 1.443 (36.7) | 1.000 | (25.4) |

1. For complete dimensions see applicable Military Specification.
2. Metric dimensions (mm) are indicated in parentheses.