

CONNECTOR DESIGNATORS
A-F-H-L-S
ROTATABLE COUPLING

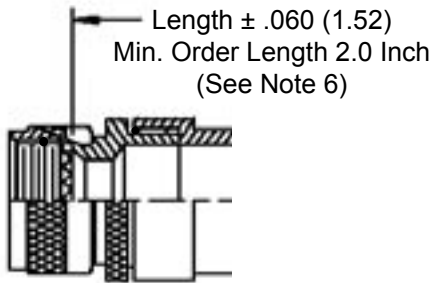

STYLE 2
(STRAIGHT
See Note 1)

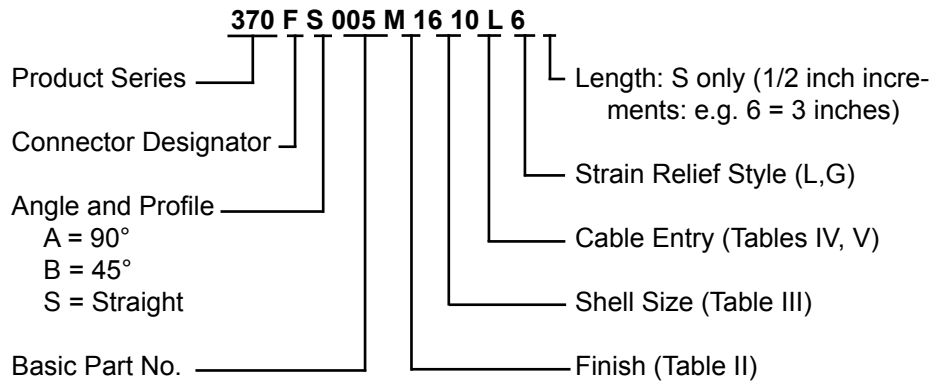
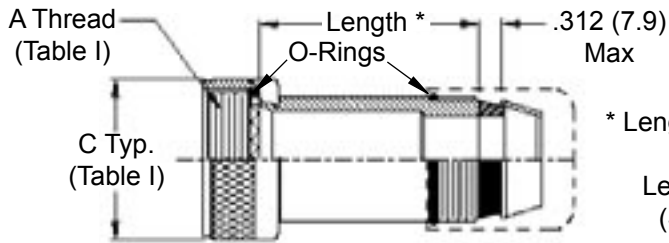

* Length ± .060 (1.52)
 Min. Order Length 1.5 Inch
 (See Note 6)

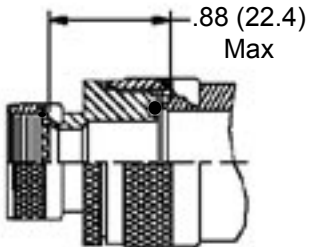

STYLE 2
(45° & 90°
See Note 1)

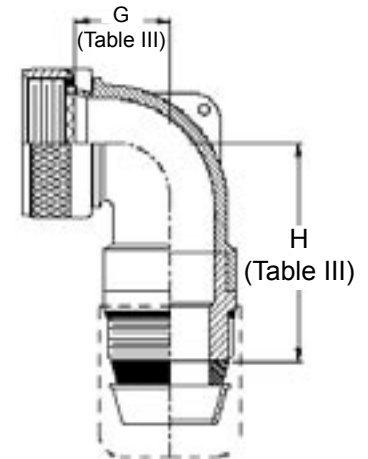
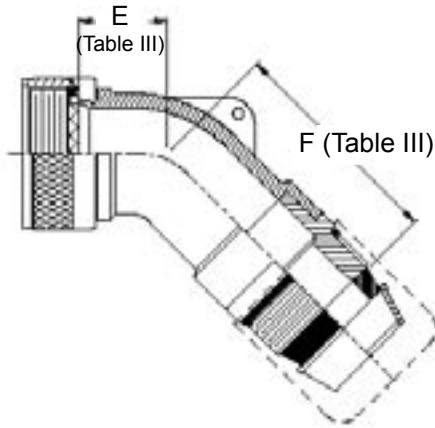

STYLE L
 Light Duty (Table IV)

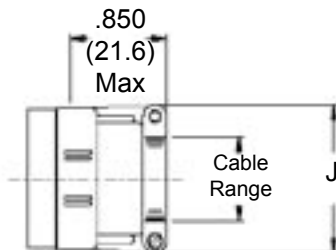

STYLE G
 Light Duty (Table V)

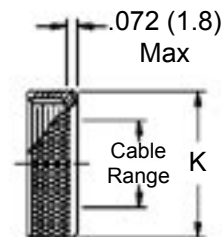

370-005
Splash-Proof Cable Sealing Backshell
 with Strain Relief
 Low Profile - Rotatable Coupling



See inside back cover fold-out or pages 13 and 14 for unabridged Tables I and II.

TABLE III: ELBOW DIMENSIONS						
Shell Size		E Max	F Max	G Max	H Max	H Max
Conn. Desig. A-F-L-S	H					
08	09	.457 (11.6)	2.030 (51.6)	.500 (12.7)	2.040 (51.8)	2.040 (51.8)
10	11	.520 (13.2)	2.030 (51.6)	.595 (15.1)	2.040 (51.8)	2.040 (51.8)
12	13	.582 (14.8)	2.090 (53.1)	.610 (15.5)	2.160 (54.9)	2.160 (54.9)
14	15	.645 (16.4)	2.150 (54.6)	.700 (17.8)	2.180 (55.4)	2.180 (55.4)
16	17	.738 (18.7)	2.240 (56.9)	.885 (22.5)	2.250 (57.2)	2.250 (57.2)
18	19	.926 (23.5)	2.340 (59.4)	.975 (24.8)	2.340 (59.4)	2.340 (59.4)
20	21	.926 (23.5)	2.340 (59.4)	.975 (24.8)	2.340 (59.4)	2.340 (59.4)
22	23	1.020 (25.9)	2.540 (64.5)	1.125 (28.6)	2.510 (63.8)	2.510 (63.8)
24	25	1.020 (25.9)	2.540 (64.5)	1.125 (28.6)	2.510 (63.8)	2.510 (63.8)
28		1.145 (29.1)	2.680 (68.1)	1.225 (31.1)	2.620 (66.5)	2.620 (66.5)
32		1.207 (30.7)	2.680 (68.1)	1.575 (40.0)	2.620 (66.5)	2.620 (66.5)
36		1.238 (31.4)	2.680 (68.1)	1.775 (45.1)	2.620 (66.5)	2.620 (66.5)

TABLE IV: CABLE ENTRY					
Dash No.	J Max	Cable Range			
		Min	Max	Min	Max
01	.781 (19.8)	.062 (1.6)	.125 (3.2)	.062 (1.6)	.125 (3.2)
02	.968 (24.6)	.125 (3.2)	.250 (6.4)	.125 (3.2)	.250 (6.4)
03	1.046 (26.6)	.250 (6.4)	.375 (9.5)	.250 (6.4)	.375 (9.5)
04	1.156 (29.4)	.250 (6.4)	.500 (12.7)	.250 (6.4)	.500 (12.7)
05	1.218 (30.9)	.375 (9.5)	.625 (15.9)	.375 (9.5)	.625 (15.9)
06	1.343 (34.1)	.500 (12.7)	.750 (19.1)	.500 (12.7)	.750 (19.1)
07	1.468 (37.3)	.625 (15.9)	.875 (22.2)	.625 (15.9)	.875 (22.2)
08	1.593 (40.5)	.625 (15.9)	1.000 (25.4)	.625 (15.9)	1.000 (25.4)
09	1.718 (43.6)	.750 (19.1)	1.125 (28.6)	.750 (19.1)	1.125 (28.6)
10	1.843 (46.8)	.875 (22.2)	1.250 (31.8)	.875 (22.2)	1.250 (31.8)

TABLE V: CABLE ENTRY					
Dash No.	K Max	Cable Range			
		Min	Max	Min	Max
01	.593 (15.1)	.062 (1.6)	.125 (3.2)	.062 (1.6)	.125 (3.2)
02	.718 (18.2)	.125 (3.2)	.250 (6.4)	.125 (3.2)	.250 (6.4)
03	.873 (22.2)	.250 (6.4)	.375 (9.5)	.250 (6.4)	.375 (9.5)
04	.968 (24.6)	.375 (9.5)	.500 (12.7)	.375 (9.5)	.500 (12.7)
05	1.109 (28.2)	.500 (12.7)	.625 (15.9)	.500 (12.7)	.625 (15.9)
06	1.218 (30.9)	.625 (15.9)	.750 (19.1)	.625 (15.9)	.750 (19.1)
07	1.343 (34.1)	.750 (19.1)	.875 (22.2)	.750 (19.1)	.875 (22.2)
08	1.468 (37.3)	.875 (22.2)	1.000 (25.4)	.875 (22.2)	1.000 (25.4)
09	1.593 (40.5)	1.000 (25.4)	1.125 (28.6)	1.000 (25.4)	1.125 (28.6)
10	1.718 (43.6)	1.125 (28.6)	1.250 (31.8)	1.125 (28.6)	1.250 (31.8)

- When maximum cable entry (page 21) is exceeded, Style 2 will be supplied.
Dimensions E, F, G and H will not apply. Please consult factory.
- Metric dimensions (mm) are indicated in parentheses.
- Cable range is defined as the accommodations range for the wire bundle or cable.
Dimensions shown are not intended for inspection criteria.
- Interface O-Ring not supplied with connector designator A.
- Consult factory for shorter lengths on straight backshells.

TABLE II: STANDARD FINISHES	
GLENAIR SYMBOL	FINISH
B	Cadmium Plate, Olive Drab
C	Anodize, Black
G	Hard Coat, Anodic
M	Electroless Nickel
NF	Cadmium Plate, Olive Drab Over Electroless Nickel

See Inside Back Cover
for Additional Finish Options