

4 Mbit (512K x 8 / 256K x 16) nvSRAM with Real-Time-Clock

Features

- 15 ns, 20 ns, 25 ns, and 45 ns access times
- Internally organized as 512K x 8 (CY14E104K) or 256K x 16 (CY14E104M)
- Hands off automatic STORE on power down with only a small capacitor
- STORE to QuantumTrap[®] nonvolatile elements is initiated by software, device pin, or AutoStore[®] on power down
- RECALL to SRAM initiated by software or power up
- High reliability
- Infinite read, write, and recall cycles
- 200,000 STORE cycles to QuantumTrap
- 20 year data retention
- Single 5V $\pm 10\%$ operation
- Data integrity of Cypress nvSRAM combined with full featured Real-Time-Clock

- Watchdog timer
- Clock alarm with programmable interrupts
- Capacitor or battery backup for RTC
- Commercial and industrial temperatures
- 44/54-pin TSOP II package
- Pb-free and RoHS compliance

Functional Description

The Cypress CY14E104K/CY14E104M combines a 4 Mbit nonvolatile static RAM with a full featured real-time-clock in a monolithic integrated circuit. The embedded nonvolatile elements incorporate QuantumTrap technology producing the world's most reliable nonvolatile memory. The SRAM is read and written an infinite number of times, while independent nonvolatile data resides in the nonvolatile elements.

The real-time-clock function provides an accurate clock with leap year tracking and a programmable, high accuracy oscillator. The alarm function is programmable for one time alarms or periodic seconds, minutes, hours, or days. There is also a programmable watchdog timer for process control.

Logic Block Diagram

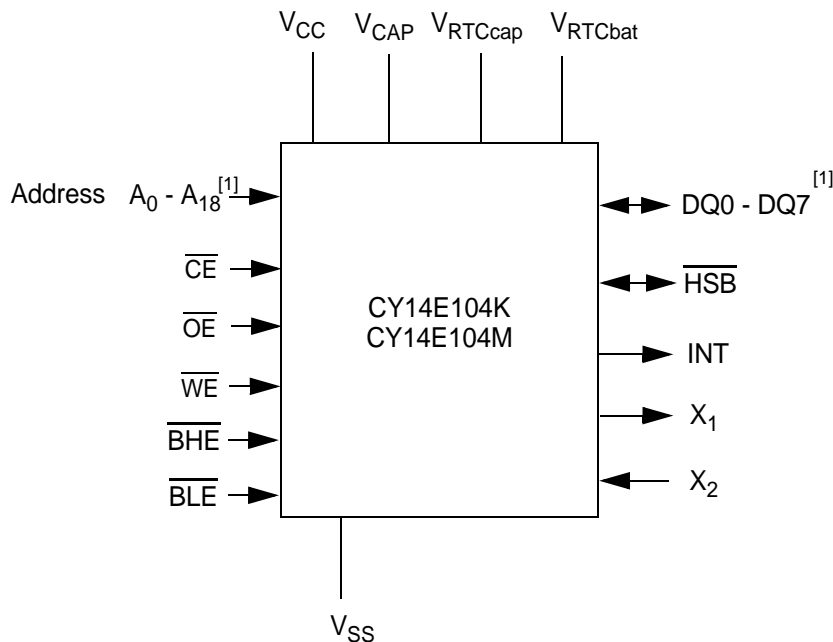

Note

1. Address A₀ - A₁₈ and DQ₀ - DQ₇ for x8 configuration, Address A₀ - A₁₇ and Data DQ₀ - DQ₁₅ for x16 configuration.

Pinouts

Figure 1. Pin Diagram - TSOP II

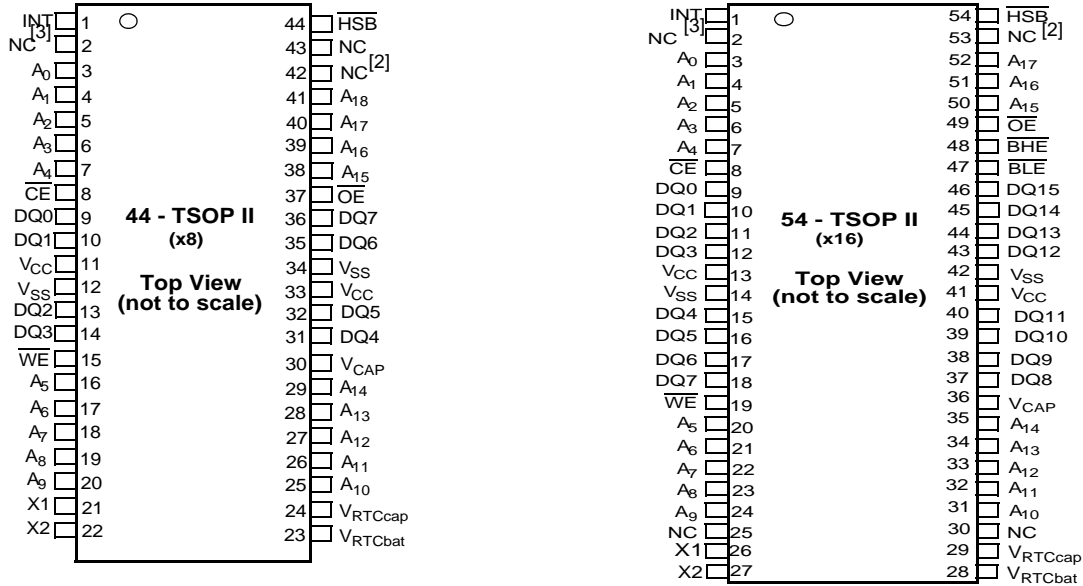

Pin Definitions

Pin Name	IO Type	Description
A ₀ – A ₁₈	Input	Address Inputs Used to Select one of the 524, 288 bytes of the nvSRAM for x8 Configuration.
A ₀ – A ₁₇		Address Inputs Used to Select one of the 262,144 bytes of the nvSRAM for x16 Configuration.
DQ ₀ – DQ ₇	Input/Output	Bidirectional Data IO Lines for x8 Configuration. Used as input or output lines depending on operation.
DQ ₀ – DQ ₁₅		Bidirectional Data IO Lines for x16 Configuration. Used as input or output lines depending on operation.
NC	No Connect	No Connects. This pin is not connected to the die.
\overline{WE}	Input	Write Enable Input, Active LOW. When selected LOW, data on the IO pins is written to the address location latched by the falling edge of \overline{CE} .
\overline{CE}	Input	Chip Enable Input, Active LOW. When LOW, selects the chip. When HIGH, deselects the chip.
\overline{OE}	Input	Output Enable, Active LOW. The active LOW \overline{OE} input enables the data output buffers during read cycles. Deasserting \overline{OE} HIGH causes the IO pins to tri-state.
\overline{BHE}	Input	Byte High Enable, Active LOW. Controls DQ ₁₅ - DQ ₈ .
\overline{BLE}	Input	Byte Low Enable, Active LOW. Controls DQ ₇ - DQ ₀ .
X ₁	Output	Crystal Connection. Drives crystal on start up.
X ₂	Input	Crystal Connection. For 32.768 kHz crystal.
V _{RTCcap}	Power Supply	Capacitor Supplied Backup RTC Supply Voltage. Left unconnected if V _{RTCbat} is used.
V _{RTCbat}	Power Supply	Battery Supplied Backup RTC Supply Voltage. Left unconnected if V _{RTCcap} is used.

Notes

- 2. Address expansion for 8 Mbit. NC pin not connected to die.
- 3. Address expansion for 16 Mbit. NC pin not connected to die.

Pin Definitions (continued)

Pin Name	IO Type	Description
INT	Output	Interrupt Output. Programmable to respond to the clock alarm, the watchdog timer, and the power monitor. Also programmable to either active HIGH (push or pull) or LOW (open drain).
V _{SS}	Ground	Ground for the Device. Must be connected to ground of the system.
V _{CC}	Power Supply	Power Supply Inputs to the Device. 5.0V +10%, -10%
$\overline{\text{HSB}}$	Input/Output	Hardware Store Busy. When LOW this output indicates that a hardware store is in progress. When pulled LOW external to the chip it initiates a nonvolatile STORE operation. A weak internal pull up resistor keeps this pin HIGH if not connected. (connection optional)
V _{CAP}	Power Supply	AutoStore Capacitor. Supplies power to the nvSRAM during power loss to store data from SRAM to nonvolatile elements.

Device Operation

The CY14E104K/CY14E104M nvSRAM is made up of two functional components paired in the same physical cell. These are a SRAM memory cell and a nonvolatile QuantumTrap cell. The SRAM memory cell operates as a standard fast static RAM. Data in the SRAM is transferred to the nonvolatile cell (the STORE operation), or from the nonvolatile cell to the SRAM (the RECALL operation). Using this unique architecture, all cells are stored and recalled in parallel. During the STORE and RECALL operations SRAM read and write operations are inhibited. The CY14E104K/CY14E104M supports infinite reads and writes similar to a typical SRAM. In addition, it provides infinite RECALL operations from the nonvolatile cells and up to 200K STORE operations.

SRAM Read

The CY14E104K/CY14E104M performs a read cycle when $\overline{\text{CE}}$ and $\overline{\text{OE}}$ are LOW and $\overline{\text{WE}}$ and $\overline{\text{HSB}}$ are HIGH. The address specified on pins A₀₋₁₈ or A₀₋₁₇ determines which of the 524,288 data bytes or 262,144 words of 16 bits each are accessed. When the read is initiated by an address transition, the outputs are valid after a delay of t_{AA} (read cycle #1). If the read is initiated by $\overline{\text{CE}}$ or $\overline{\text{OE}}$, the outputs are valid at t_{ACE} or at t_{DOE}, whichever is later (read cycle #2). The data output repeatedly responds to address changes within the t_{AA} access time without the need for transitions on any control input pins. This remains valid until another address change or until $\overline{\text{CE}}$ or $\overline{\text{OE}}$ is brought HIGH, or $\overline{\text{WE}}$ or $\overline{\text{HSB}}$ is brought LOW.

SRAM Write

A write cycle is performed when $\overline{\text{CE}}$ and $\overline{\text{WE}}$ are LOW and $\overline{\text{HSB}}$ is HIGH. The address inputs must be stable before entering the write cycle and must remain stable until $\overline{\text{CE}}$ or $\overline{\text{WE}}$ goes HIGH at the end of the cycle. The data on the common IO pins IO₀₋₇ are written into the memory if it is valid t_{SD} before the end of a $\overline{\text{WE}}$ controlled write or before the end of an $\overline{\text{CE}}$ controlled write. It is recommended that $\overline{\text{OE}}$ be kept HIGH during the entire write cycle to avoid data bus contention on common IO lines. If $\overline{\text{OE}}$ is left LOW, internal circuitry turns off the output buffers t_{HZWE} after $\overline{\text{WE}}$ goes LOW.

AutoStore Operation

The CY14E104K/CY14E104M stores data to the nvSRAM using one of three storage operations. These three operations are: Hardware Store, activated by $\overline{\text{HSB}}$; Software Store, activated by an address sequence; AutoStore, on device power down. The AutoStore operation is a unique feature of QuantumTrap technology and is enabled by default on the CY14E104K/CY14E104M.

During normal operation, the device draws current from V_{CC} to charge a capacitor connected to the V_{CAP} pin. This stored charge is used by the chip to perform a single STORE operation. If the voltage on the V_{CC} pin drops below V_{SWITCH}, the part automatically disconnects the V_{CAP} pin from V_{CC}. A STORE operation is initiated with power provided by the V_{CAP} capacitor.

Figure 2. AutoStore Mode

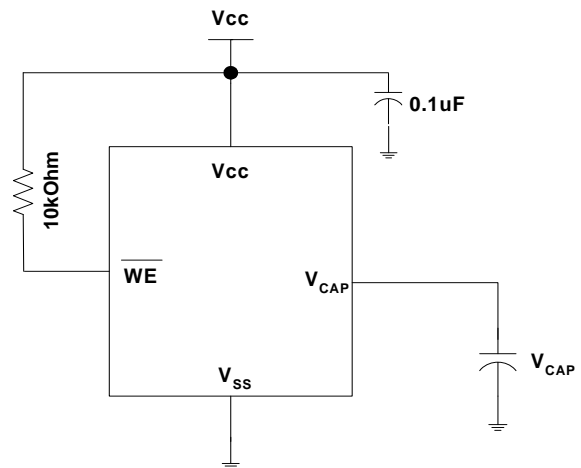

Figure 2 shows the proper connection of the storage capacitor (V_{CAP}) for automatic store operation. Refer to DC Electrical Characteristics on page 14 for the size of the V_{CAP}.

To reduce unnecessary nonvolatile stores, AutoStore and hardware store operations are ignored unless at least one write operation has taken place since the most recent STORE or RECALL cycle. Software initiated STORE cycles are performed regardless of whether a write operation has taken place. The $\overline{\text{HSB}}$ signal is monitored by the system to detect if an AutoStore cycle is in progress.

Hardware STORE (HSB) Operation

The CY14E104K/CY14E104M provides the $\overline{\text{HSB}}$ pin to control and acknowledge the STORE operations. The $\overline{\text{HSB}}$ pin is used to request a hardware STORE cycle. When the $\overline{\text{HSB}}$ pin is driven LOW, the CY14E104K/CY14E104M conditionally initiates a STORE operation after t_{DELAY} . An actual STORE cycle begins only if a write to the SRAM has taken place since the last STORE or RECALL cycle. The $\overline{\text{HSB}}$ pin also acts as an open drain driver that is internally driven LOW to indicate a busy condition when the STORE (initiated by any means) is in progress.

SRAM read and write operations that are in progress when $\overline{\text{HSB}}$ is driven LOW by any means are given time to complete before the STORE operation is initiated. After $\overline{\text{HSB}}$ goes LOW, the CY14E104K/CY14E104M continues SRAM operations for t_{DELAY} . During t_{DELAY} , multiple SRAM read operations may take place. If a write is in progress when $\overline{\text{HSB}}$ is pulled LOW it is allowed a time, t_{DELAY} , to complete. However, any SRAM write cycles requested after $\overline{\text{HSB}}$ goes LOW is inhibited until $\overline{\text{HSB}}$ returns HIGH.

During any STORE operation, regardless of how it is initiated, the CY14E104K/CY14E104M continues to drive the $\overline{\text{HSB}}$ pin LOW, releasing it only when the STORE is complete. Upon completion of the STORE operation, the CY14E104K/CY14E104M remains disabled until the $\overline{\text{HSB}}$ pin returns HIGH. Leave the $\overline{\text{HSB}}$ unconnected if it is not used.

Hardware RECALL (Power Up)

During power up, or after any low power condition ($V_{\text{CC}} < V_{\text{SWITCH}}$), an internal RECALL request is latched. When V_{CC} again exceeds the sense voltage of V_{SWITCH} , a RECALL cycle is automatically initiated and takes t_{HRECALL} to complete.

Software STORE

Data is transferred from the SRAM to the nonvolatile memory by a software address sequence. The CY14E104K/CY14E104M software STORE cycle is initiated by executing sequential $\overline{\text{CE}}$ controlled read cycles from six specific address locations in exact order. During the STORE cycle, an erase of the previous nonvolatile data is first performed, followed by a program of the nonvolatile elements. After a STORE cycle is initiated, further input and output are disabled until the cycle is completed.

Because a sequence of reads from specific addresses is used for STORE initiation, it is important that no other read or write accesses intervene in the sequence, or the sequence is aborted and no STORE or RECALL takes place.

To initiate the software STORE cycle, the following read sequence must be performed:

1. Read address 0x4E38 Valid READ
2. Read address 0xB1C7 Valid READ
3. Read address 0x83E0 Valid READ
4. Read address 0x7C1F Valid READ
5. Read address 0x703F Valid READ
6. Read address 0x8FC0 Initiate STORE cycle

The software sequence may be clocked with $\overline{\text{CE}}$ controlled reads or $\overline{\text{OE}}$ controlled reads. After the sixth address in the sequence is entered, the STORE cycle commences and the chip is disabled. It is important to use read cycles and not write cycles in the sequence, although it is not necessary that $\overline{\text{OE}}$ be LOW for a valid sequence. After the t_{STORE} cycle time is fulfilled, the SRAM is activated again for read and write operations.

Software RECALL

Data is transferred from the nonvolatile memory to the SRAM by a software address sequence. A software RECALL cycle is initiated with a sequence of read operations in a manner similar to the software STORE initiation. To initiate the RECALL cycle, the following sequence of $\overline{\text{CE}}$ controlled read operations must be performed:

1. Read address 0x4E38 Valid READ
2. Read address 0xB1C7 Valid READ
3. Read address 0x83E0 Valid READ
4. Read address 0x7C1F Valid READ
5. Read address 0x703F Valid READ
6. Read address 0x4C63 Initiate RECALL cycle

Internally, RECALL is a two step procedure. First, the SRAM data is cleared; then, the nonvolatile information is transferred into the SRAM cells. After the t_{RECALL} cycle time the SRAM is again ready for read and write operations. The RECALL operation in no way alters the data in the nonvolatile elements.

Table 1. Mode Selection

\overline{CE}	\overline{WE}	\overline{OE}	A15 - A0	Mode	IO	Power
H	X	X	X	Not Selected	Output High Z	Standby
L	H	L	X	Read SRAM	Output Data	Active
L	L	X	X	Write SRAM	Input Data	Active
L	H	L	0x4E38 0xB1C7 0x83E0 0x7C1F 0x703F 0x8B45	Read SRAM Read SRAM Read SRAM Read SRAM Read SRAM AutoStore Disable	Output Data Output Data Output Data Output Data Output Data Output Data	Active ^[4, 5, 6]
L	H	L	0x4E38 0xB1C7 0x83E0 0x7C1F 0x703F 0x4B46	Read SRAM Read SRAM Read SRAM Read SRAM Read SRAM AutoStore Enable	Output Data Output Data Output Data Output Data Output Data Output Data	Active ^[4, 5, 6]
L	H	L	0x4E38 0xB1C7 0x83E0 0x7C1F 0x703F 0x8FC0	Read SRAM Read SRAM Read SRAM Read SRAM Read SRAM Nonvolatile Store	Output Data Output Data Output Data Output Data Output Data Output High Z	Active I _{CC2} ^[4, 5, 6]
L	H	L	0x4E38 0xB1C7 0x83E0 0x7C1F 0x703F 0x4C63	Read SRAM Read SRAM Read SRAM Read SRAM Read SRAM Nonvolatile Recall	Output Data Output Data Output Data Output Data Output Data Output High Z	Active ^[4, 5, 6]

Preventing AutoStore

The AutoStore function is disabled by initiating an AutoStore disable sequence. A sequence of read operations is performed in a manner similar to the software STORE initiation. To initiate the AutoStore disable sequence, the following sequence of \overline{CE} controlled read operations must be performed:

1. Read address 0x4E38 Valid READ
2. Read address 0xB1C7 Valid READ
3. Read address 0x83E0 Valid READ
4. Read address 0x7C1F Valid READ
5. Read address 0x703F Valid READ
6. Read address 0x8B45 AutoStore Disable

The AutoStore is re-enabled by initiating an AutoStore enable sequence. A sequence of read operations is performed in a manner similar to the software RECALL initiation. To initiate the AutoStore enable sequence, the following sequence of \overline{CE} controlled read operations must be performed:

1. Read address 0x4E38 Valid READ
2. Read address 0xB1C7 Valid READ
3. Read address 0x83E0 Valid READ
4. Read address 0x7C1F Valid READ
5. Read address 0x703F Valid READ
6. Read address 0x4B46 AutoStore Enable

If the AutoStore function is disabled or re-enabled, a manual STORE operation (hardware or software) is issued to save the AutoStore state through subsequent power down cycles. The part comes from the factory with AutoStore enabled.

Notes

4. The six consecutive address locations must be in the order listed. \overline{WE} must be HIGH during all six cycles to enable a nonvolatile cycle.
5. While there are 19 address lines on the CY14E104K/CY14E104M, only the lower 16 lines are used to control software modes.
6. IO state depends on the state of OE, BHE, and BLE. The IO table shown assumes OE, BHE, and BLE LOW.

Data Protection

The CY14E104K/CY14E104M protects data from corruption during low voltage conditions by inhibiting all externally initiated STORE and write operations. The low voltage condition is detected when $V_{CC} < V_{SWITCH}$. If the CY14E104K/ CY14E104M is in a write mode (both CE and WE LOW) at power up, after a RECALL, or after a STORE, the write is inhibited until a negative transition on CE or WE is detected. This protects against inadvertent writes during power up or brown out conditions.

Noise Considerations

Refer CY application note [AN1064](#).

Real-Time-Clock Operation

nvTIME Operation

The CY14E104K/CY14E104M offers internal registers that contain clock, alarm, watchdog, interrupt, and control functions. Internal double buffering of the clock and the clock or timer information registers prevents accessing transitional internal clock data during a read or write operation. Double buffering also circumvents disrupting normal timing counts or the clock accuracy of the internal clock when accessing clock data. Clock and alarm registers store data in BCD format.

Clock Operations

The clock registers maintain time up to 9,999 years in one second increments. The time can be set to any calendar time and the clock automatically keeps track of days of the week and month, leap years, and century transitions. There are eight registers dedicated to the clock functions, which are used to set time with a write cycle and to read time during a read cycle. These registers contain the time of day in BCD format. Bits defined as '0' are currently not used and are reserved for future use by Cypress.

Reading the Clock

While the double buffered RTC register structure reduces the chance of reading incorrect data from the clock, stop internal updates to the CY14E104K/CY14E104M clock registers before reading clock data, to prevent reading of data in transition. Stopping the internal register updates does not affect clock accuracy. The updating process is stopped by writing a '1' to the read bit 'R' (in the flags register at 0x1FFF0), and does not restart until a '0' is written to the read bit. The RTC registers are then read while the internal clock continues to run. Within 20 ms after a '0' is written to the read bit, all CY14E104K/CY14E104M registers are simultaneously updated.

Setting the Clock

Setting the write bit 'W' (in the flags register at 0x1FFF0) to a '1' stops updates to the CY14E104K/CY14E104M registers. The correct day, date, and time is then written into the registers in 24 hour BCD format. The time written is referred to as the "Base Time". This value is stored in nonvolatile registers and used in the calculation of the current time. Resetting the write bit to '0' transfers those values to the actual clock counters, after which the clock resumes normal operation.

Backup Power

The RTC in the CY14E104K/CY14E104M is intended for permanently powered operations. The V_{RTCcap} or V_{RTCbat} pin is connected depending on whether a capacitor or battery is chosen for the application. When the primary power, V_{CC} , fails and drops below V_{SWITCH} , the device switches to the backup power supply.

The clock oscillator uses very little current, which maximizes the backup time available from the backup source. Regardless of clock operation with the primary source removed, the data stored in nvSRAM is secure, having been stored in the nonvolatile elements when power was lost.

During backup operation, the CY14E104K/CY14E104M consumes a maximum of 300 nanoamps at 2 volts. Capacitor or battery values must be chosen according to the application. Backup time values based on maximum current specifications are shown in the following table. Nominal times are approximately three times longer.

Table 2. RTC Backup Time

Capacitor Value	Backup Time
0.1F	72 hours
0.47F	14 days
1.0F	30 days

Using a capacitor has the obvious advantage of recharging the backup source each time the system is powered up. If a battery is used, a 3V lithium is recommended and the CY14E104K/CY14E104M sources current only from the battery when the primary power is removed. The battery is not, however, recharged at any time by the CY14E104K/CY14E104M. The battery capacity must be chosen for total anticipated cumulative down time required over the life of the system.

Stopping and Starting the Oscillator

The OSCEN bit in the calibration register at 0x1FFF8 controls the start and stop of the oscillator. This bit is nonvolatile and shipped to customers in the "enabled" (set to 0) state. To preserve the battery life when the system is in storage OSCEN must be set to '1'. This turns off the oscillator circuit extending the battery life. If the OSCEN bit goes from disabled to enabled, it takes approximately 5 seconds (10 seconds maximum) for the oscillator to start.

The CY14E104K/CY14E104M has the ability to detect oscillator failure. This is recorded in the OSCF (Oscillator Failed bit) of the flags register at the address 0x1FFF0. When the device is powered on (V_{CC} goes above V_{SWITCH}) the OSCEN bit is checked for "enabled" status. If the OSCEN bit is enabled and the oscillator is not active, the OSCF bit is set. Check for this condition and then write '0' to clear the flag. Note that in addition to setting the OSCF flag bit, the time registers are reset to the "Base Time" (see [Setting the Clock](#) on page 6), which is the value last written to the timekeeping registers. The control or calibration registers and the OSCEN bit are not affected by the 'oscillator failed' condition.

If the voltage on the backup supply (either V_{RTCcap} or $V_{RTCbatt}$) falls below their respective minimum level, the oscillator may fail, leading to the oscillator failed condition which is detected when system power is restored.

The value of OSCF must be reset to '0' when the time registers are written for the first time. This initializes the state of this bit which may have become set when the system was first powered on.

Calibrating the Clock

The RTC is driven by a quartz controlled oscillator with a nominal frequency of 32.768 kHz. Clock accuracy depends on the quality of the crystal, usually specified to 35 ppm limits at 25°C. This error could equate to +1.53 minutes per month. The CY14E104K/CY14E104M employs a calibration circuit that improves the accuracy to +1/-2 ppm at 25°C. The calibration circuit adds or subtracts counts from the oscillator divider circuit.

The number of times pulses are suppressed (subtracted, negative calibration) or split (added, positive calibration) depends on the value loaded into the five calibration bits found in the calibration register at 0x1FFF8. Adding counts speeds the clock up; subtracting counts slows the clock down. The calibration bits occupy the five lower order bits in the control register 8. These bits are set to represent any value between 0 and 31 in binary form. Bit D5 is a sign bit, where '1' indicates positive calibration and '0' indicates negative calibration. Calibration occurs within a 64 minute cycle. The first 62 minutes in the cycle may, once per minute, have one second either shortened by 128 or lengthened by 256 oscillator cycles.

If a binary '1' is loaded into the register, only the first 2 minutes of the 64 minute cycle are modified; if a binary '6' is loaded, the first 12 are affected, and so on. Therefore, each calibration step has the effect of adding 512 or subtracting 256 oscillator cycles for every 125,829,120 actual oscillator cycles. That is 4.068 or -2.034 ppm of adjustment for every calibration step in the calibration register.

To determine how to set the calibration, the CAL bit in the flags register at 0x1FFF0 is set to '1', which causes the INT pin to toggle at a nominal 512 Hz. Any deviation measured from the 512 Hz indicates the degree and direction of the required correction. For example, a reading of 512.010124 Hz indicates a +20 ppm error, which requires the loading of a -10 (001010) into the calibration register. Note that setting or changing the calibration register does not affect the frequency test output frequency.

Alarm

The alarm function compares user programmed values with the corresponding time of day values. When a match occurs, the alarm event occurs. The alarm drives an internal flag, AF, and may drive the INT pin if desired.

There are four alarm match fields. They are date, hours, minutes, and seconds. Each of these fields has a match bit that is used to determine if the field is used in the alarm match logic. Setting the match bit to '0' indicates that the corresponding field is used in the match process.

Depending on the match bits, the alarm can occur as specifically as one particular second on one day of the month, or as frequently as once per second continuously. The MSB of each alarm register is a match bit. Selecting none of the match bits (all 1s) indicates that no match is required. The alarm occurs every second. Setting the match select bit for seconds to '0' causes the logic to match the seconds alarm value to the current time of day. Since a match occurs for only one value per minute, the alarm occurs once per minute. Similarly, setting the seconds and minutes match bits causes an exact match of these values. Thus, an alarm occurs once per hour. Setting seconds, minutes, and hours causes a match once per day. Lastly, selecting all match values causes an exact time and date match. Selecting other bit combinations does not produce meaningful results; however, the alarm circuit must follow the functions described.

There are two ways to detect an alarm event: by reading the AF flag or by monitoring the INT pin. The AF flag in the flags register at 0x1FFF0 indicates that a date or time match has occurred. The AF bit is set to '1' when a match occurs. Reading the flags or control register clears the alarm flag bit (and all others). A hardware interrupt pin is used to detect an alarm event.

Watchdog Timer

The watchdog timer is a free running down counter that uses the 32 Hz clock (31.25 ms) derived from the crystal oscillator. The oscillator must be running for the watchdog to function. It begins counting down from the value loaded in the watchdog timer register.

The counter consists of a loadable register and a free running counter. On power up, the watchdog timeout value in register 0x1FFF7 is loaded into the counter load register. Counting begins on power up and restarts from the loadable value any time the Watchdog Strobe (WDS) bit is set to '1'. The counter is compared to the terminal value of 0. If the counter reaches this value, it causes an internal flag and an optional interrupt output. The timeout interrupt is prevented by setting WDS bit to '1' before the counter reaches '0'. This causes the counter to reload with the watchdog timeout value and get restarted. As long as the WDS bit is set before the counter reaches the terminal value, the interrupt and flag never occurs.

New timeout values are written by setting the watchdog write bit to '0'. When the WDW is '0' (from the previous operation), new writes to the watchdog timeout value bits D5-D0 allow the modification of timeout values. When WDW is '1', then writes to bits D5-D0 are ignored. The WDW function allows to set the WDS bit without concern that the watchdog timer value is modified. A logical diagram of the watchdog timer is shown in Figure 3 on page 8. Note that setting the watchdog timeout value to '0' is otherwise meaningless and as a result, disables the watchdog function.

The output of the watchdog timer is a flag bit WDF that is set if the watchdog is allowed to timeout. The flag is set upon a watchdog timeout and cleared when the flags control register is read by the user. The user can also enable an optional interrupt source to drive the INT pin if the watchdog timeout occurs.

Figure 3. Watchdog Timer Block Diagram

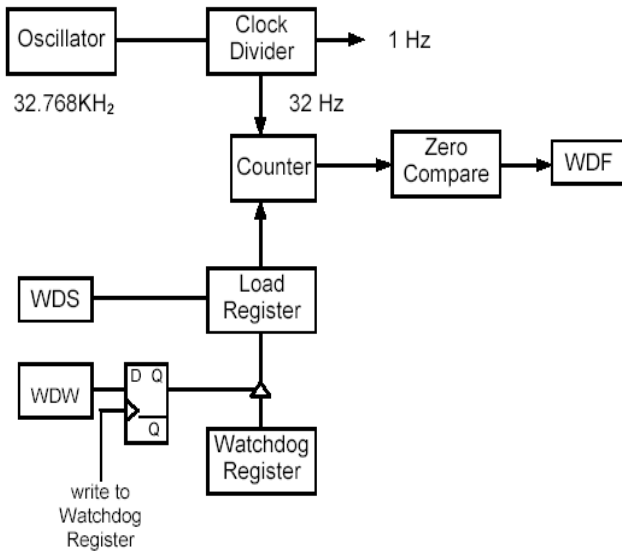

Power Monitor

The CY14E104K/CY14E104M provides a power management scheme with power fail interrupt capability. It also controls the internal switch to backup power for the clock and protects the memory from low V_{CC} access. The power monitor is based on an internal band gap reference circuit that compares the V_{CC} voltage to various thresholds.

As described in the section [AutoStore Operation](#) on page 3, when V_{SWITCH} is reached as V_{CC} decays from power loss, a data store operation is initiated from SRAM to the nonvolatile elements, securing the last SRAM data state. Power is also switched from V_{CC} to the backup supply (battery or capacitor) to operate the RTC oscillator.

When operating from the backup source, no data is read or written and the clock functions are not available to the user. The clock continues to operate in the background. The updated clock data is available to the user after $t_{HRECALL}$ delay (see [AutoStore/Power Up RECALL](#) on page 16) after V_{CC} is restored to the device.

Interrupts

The CY14E104K/CY14E104M provides three potential interrupt sources. They include the watchdog timer, the power monitor, and the clock or calendar alarm. Each are individually enabled and assigned to drive the INT pin. In addition, each has an associated flag bit that the host processor can use to determine the cause of the interrupt. Some of the sources have additional control bits that determine functional behavior. In addition, the pin driver has three bits that specify its behavior when an interrupt occurs.

The three interrupts each have a source and an enable. Both the source and the enable must be active (true HIGH) to generate

an interrupt output. Only one source is necessary to drive the pin. The user can identify the source by reading the flags or control register, which contains the flags associated with each source. All flags are cleared to '0' when the register is read. The cycle must be a complete read cycle (WE HIGH); otherwise, the flags are not cleared. The power monitor has two programmable settings that are explained in [Power Monitor](#) on page 8.

After an interrupt source is active, the pin driver determines the behavior of the output. It has two programmable settings. Pin driver control bits are located in the interrupts register.

According to the programming selections, the pin is driven in the backup mode for an alarm interrupt. In addition, the pin is an active LOW (open drain) or an active HIGH (push pull) driver. If programmed for operation during backup mode, it is active LOW. Lastly, the pin provides a one shot function so that the active condition is a pulse or a level condition. In one shot mode, the pulse width is internally fixed at approximately 200 ms. This mode is intended to reset a host microcontroller. In the level mode, the pin goes to its active polarity until the flags or control register is read by the user. This mode is used as an interrupt to a host microcontroller. The control bits are summarized as follows.

Watchdog Interrupt Enable - WIE. When set to '1', the watchdog timer drives the INT pin and an internal flag when a watchdog timeout occurs. When WIE is set to '0', the watchdog timer affects only the internal flag.

Alarm Interrupt Enable - AIE. When set to '1', the alarm match drives the INT pin and an internal flag. When set to '0', the alarm match only affects the internal flag.

Power Fail Interrupt Enable - PFE. When set to '1', the power fail monitor drives the pin and an internal flag. When set to '0', the power fail monitor affects only the internal flag.

High/Low - H/L. When set to a '1', the INT pin is active HIGH and the driver mode is push pull. The INT pin can drive HIGH only when $V_{CC} > V_{SWITCH}$. When set to '0', the INT pin is active LOW and the drive mode is open drain. Active LOW (open drain) is operational even in battery backup mode.

Pulse/Level - P/L. When set to '1' and an interrupt occurs, the INT pin is driven for approximately 200 ms. When P/L is set to '0', the INT pin is driven HIGH or LOW (determined by H/L) until the flags or control register is read.

When an enabled interrupt source activates the INT pin, an external host can read the flags or control register to determine the cause. All flags are cleared when the register is read. If the INT pin is programmed for level mode, then the condition clears and the INT pin returns to its inactive state. If the pin is programmed for pulse mode, then reading the flag also clears the flag and the pin. The pulse does not complete its specified duration if the flags or control register is read. If the INT pin is used as a host reset, then the flags or control register must not be read during a reset.

During a power on reset with no battery, the interrupt register is automatically loaded with the value 24h. This enables the power fail interrupt with an active LOW pulse.

Figure 4. RTC Recommended Component Configuration

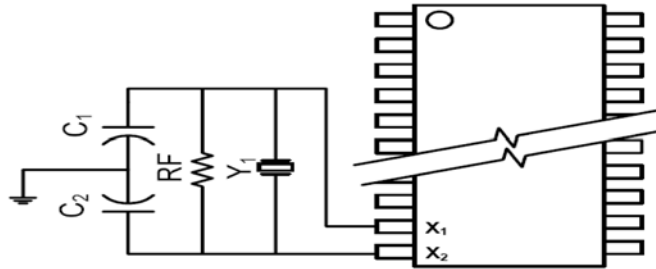

Recommended Values

Y1 = 32.768KHz
 RF = 10M Ohm
 C₁ = 0
 C₂ = 56 pF

Figure 5. Interrupt Block Diagram

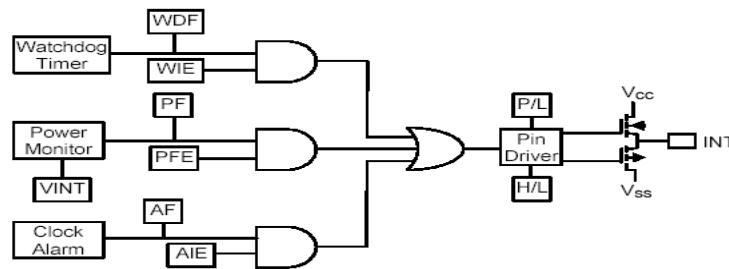

Legend

WDF - Watchdog Timer Flag
 WIE - Watchdog Interrupt Enable
 PF - Power fail Flag
 PFE - Power Fail Enable
 AF - Alarm Flag
 AIE - Alarm Interrupt Enable
 P/L - Pulse Level
 H/L - HIGH/LOW

Table 3. RTC Register Map

Register	BCD Format Data								Function/Range
	D7	D6	D5	D4	D3	D2	D1	D0	
0x1FFFF	10s Years				Years				Years: 00–99
0x1FFFE	0	0	0	10s Months	Months				Months: 01–12
0x1FFFD	0	0	10s Day of Month		Day Of Month				Day of Month: 01–31
0x1FFFC	0	0	0	0	0	Day of week			Day of week: 01–07
0x1FFFB	0	0	10s Hours		Hours				Hours: 00–23
0x1FFFA	0	10s Minutes			Minutes				Minutes: 00–59
0x1FFF9	10s Seconds			Seconds					Seconds: 00–59
0x1FFF8	OSCEN	0	Cal Sign	Calibration					Calibration Values ^[7]
0x1FFF7	WDS	WDW	WDT						Watchdog ^[7]
0x1FFF6	WIE	AIE	PFE	0	H/L	P/L	0	0	Interrupts ^[7]
0x1FFF5	M	0	10s Alarm Date		Alarm Date				Alarm, Day of Month: 01–31
0x1FFF4	M	0	10s Alarm Hours		Alarm Hours				Alarm, Hours: 00–23
0x1FFF3	M	10 Alarm Minutes			Alarm Minutes				Alarm, Minutes: 00–59
0x1FFF2	M	10 Alarm Seconds			Alarm Seconds				Alarm, Seconds: 00–59
0x1FFF1	10s Centuries				Centuries				Centuries: 00–99
0x1FFF0	WDF	AF	PF	OSCF	0	CAL	W	R	Flags ^[7]

Note

7. This is a binary value, not a BCD value.

Table 4. Register Map Detail

0x1FFF	Time Keeping - Years							
	D7	D6	D5	D4	D3	D2	D1	D0
	10s Years				Years			
	Contains the lower two BCD digits of the year. Lower nibble contains the value for years; upper nibble contains the value for 10s of years. Each nibble operates from 0 to 9. The range for the register is 0–99.							
0x1FFE	Time Keeping - Months							
	D7	D6	D5	D4	D3	D2	D1	D0
	0	0	0	10s Month	Months			
	Contains the BCD digits of the month. Lower nibble contains the lower digit and operates from 0 to 9; upper nibble (one bit) contains the upper digit and operates from 0 to 1. The range for the register is 1–12.							
0x1FFD	Time Keeping - Date							
	D7	D6	D5	D4	D3	D2	D1	D0
	0	0	10s Day of Month		Day of Month			
	Contains the BCD digits for the date of the month. Lower nibble contains the lower digit and operates from 0 to 9; upper nibble contains the upper digit and operates from 0 to 3. The range for the register is 1–31. Leap years are automatically adjusted for.							
0x1FFC	Time Keeping - Day							
	D7	D6	D5	D4	D3	D2	D1	D0
	0	0	0	0	0	Day of Week		
	Lower nibble contains a value that correlates to day of the week. Day of the week is a ring counter that counts from 1 to 7 then returns to 1. The user must assign meaning to the day value, because the day is not integrated with the date.							
0x1FFB	Time Keeping - Hours							
	D7	D6	D5	D4	D3	D2	D1	D0
	12/24	0	10s Hours		Hours			
	Contains the BCD value of hours in 24 hour format. Lower nibble contains the lower digit and operates from 0 to 9; upper nibble (two bits) contains the upper digit and operates from 0 to 2. The range for the register is 0–23.							
0x1FFA	Time Keeping - Minutes							
	D7	D6	D5	D4	D3	D2	D1	D0
	0	10s Minutes			Minutes			
	Contains the BCD value of minutes. Lower nibble contains the lower digit and operates from 0 to 9; upper nibble contains the upper minutes digit and operates from 0 to 5. The range for the register is 0–59.							
0x1FF9	Time Keeping - Seconds							
	D7	D6	D5	D4	D3	D2	D1	D0
	0	10s Seconds			Seconds			
	Contains the BCD value of seconds. Lower nibble contains the lower digit and operates from 0 to 9; upper nibble contains the upper digit and operates from 0 to 5. The range for the register is 0–59.							
0x1FF8	Calibration/Control							
	D7	D6	D5	D4	D3	D2	D1	D0
	OSCEN	0	Calibration Sign	Calibration				
OSCEN	Oscillator Enable. When set to 1, the oscillator is stopped. When set to 0, the oscillator runs. Disabling the oscillator saves battery or capacitor power during storage. On a no-battery power up, this bit is set to 0.							
Calibration Sign	Determines if the calibration adjustment is applied as an addition to or as a subtraction from the time-base.							
Calibration	These five bits control the calibration of the clock.							

Table 4. Register Map Detail (continued)

0x1FFF7	WatchDog Timer							
	D7	D6	D5	D4	D3	D2	D1	D0
	WDS	WDW	WDT					
WDS	Watchdog Strobe. Setting this bit to 1 reloads and restarts the watchdog timer. Setting the bit to 0 has no effect. The bit is cleared automatically after the watchdog timer is reset. The WDS bit is write only. Reading it always returns a 0.							
WDW	Watchdog Write Enable. Setting this bit to 1 masks the watchdog timeout value (WDT5–WDT0) so it cannot be written. This allows the user to strobe the watchdog without disturbing the timeout value. Setting this bit to 0 allows bits 5–0 to be written on the next write to the watchdog register. The new value is loaded on the next internal watchdog clock after the write cycle is complete. This function is explained in more detail in Watchdog Timer on page 7.							
WDT	Watchdog timeout selection. The watchdog timer interval is selected by the 6-bit value in this register. It represents a multiplier of the 32 Hz count (31.25 ms). The minimum range or timeout value is 31.25 ms (a setting of 1) and the maximum timeout is 2 seconds (setting of 3 Fh). Setting the watchdog timer register to 0 disables the timer. These bits are written only if the WDW bit was cleared to 0 on a previous cycle.							
0x1FFF6	Interrupt Status/Control							
	D7	D6	D5	D4	D3	D2	D1	D0
	WIE	AIE	PFIE	0	H/L	P/L	0	0
WIE	Watchdog Interrupt Enable. When set to 1 and a watchdog timeout occurs, the watchdog timer drives the INT pin and the WDF flag. When set to 0, the watchdog timeout affects only the WDF flag.							
AIE	Alarm Interrupt Enable. When set to 1, the alarm match drives the INT pin and the AF flag. When set to 0, the alarm match only affects the AF flag.							
PFIE	Power Fail Enable. When set to 1, the alarm match drives the INT pin and the AF flag. When set to 0, the power fail monitor affects only the PF flag.							
H/L	High/Low. When set to a 1, the INT pin is driven active HIGH. When set to 0, the INT pin is open drain, active LOW.							
P/L	Pulse/Level. When set to a 1, the INT pin is driven active (determined by H/L) by an interrupt source for approximately 200 ms. When set to a 0, the INT pin is driven to an active level (as set by H/L) until the flags or control register is read.							
0x1FFF5	Alarm - Day							
	D7	D6	D5	D4	D3	D2	D1	D0
	M	0	10s Alarm Date			Alarm Date		
Contains the alarm value for the date of the month and the mask bit to select or deselect the date value.								
M	Match. When this bit is set to 0, the date value is used in the alarm match. Setting this bit to 1 causes the match circuit to ignore the date value.							
0x1FFF4	Alarm - Hours							
	D7	D6	D5	D4	D3	D2	D1	D0
	M	0	10s Alarm Hours			Alarm Hours		
Contains the alarm value for the hours and the mask bit to select or deselect the hours value.								
M	Match. When this bit is set to 0, the hours value is used in the alarm match. Setting this bit to 1 causes the match circuit to ignore the hours value.							
0x1FFF3	Alarm - Minutes							
	D7	D6	D5	D4	D3	D2	D1	D0
	M	0	10s Alarm Minutes			Alarm Minutes		
Contains the alarm value for the minutes and the mask bit to select or deselect the minutes value.								
M	Match. When this bit is set to 0, the minutes value is used in the alarm match. Setting this bit to 1 causes the match circuit to ignore the minutes value.							
0x1FFF2	Alarm - Seconds							
	D7	D6	D5	D4	D3	D2	D1	D0
	M	0	10s Alarm Seconds			Alarm Seconds		
Contains the alarm value for the seconds and the mask bit to select or deselect the seconds' value.								

Table 4. Register Map Detail (continued)

M	Match. When this bit is set to 0, the seconds' value is used in the alarm match. Setting this bit to 1 causes the match circuit to ignore the seconds value.							
0x1FFF1	Time Keeping - Centuries							
	D7	D6	D5	D4	D3	D2	D1	D0
	0	0	10s Centuries		Centuries			
0x1FFF0	Flags							
	D7	D6	D5	D4	D3	D2	D1	D0
	WDF	AF	PF	OSCF	0	CAL	W	R
WDF	Watchdog Timer Flag. This read only bit is set to 1 when the watchdog timer is allowed to reach 0 without being reset by the user. It is cleared to 0 when the Flags/Control register is read.							
AF	Alarm Flag. This read only bit is set to 1 when the time and date match the values stored in the alarm registers with the match bits = 0. It is cleared when the Flags/Control register is read.							
PF	Power Fail Flag. This read only bit is set to 1 when power falls below the power fail threshold V_{SWITCH} . It is cleared to 0 when the Flags/Control register is read.							
OSCF	Oscillator Fail Flag. Set to 1 on power up only if the oscillator is not running in the first 5 ms of power on operation. This indicates that time counts are no longer valid. The user must reset this bit to 0 to clear this condition. The chip does not clear this flag. This bit survives power cycles.							
CAL	Calibration Mode. When set to 1, a 512 Hz square wave is output on the INT pin. When set to 0, the INT pin resumes normal operation. This bit defaults to 0 (disabled) on power up.							
W	Write Time. Setting the W bit to 1 freeze updates of the timekeeping registers. The user can then write them with updated values. Setting the W bit to 0 transfers the contents of the time registers to the timekeeping counters.							
R	Read Time. Setting the R bit to 1 copies a static image of the timekeeping registers and places them in a holding register. The user can then read them without concerns over changing values causing system errors. The R bit going from 0 to 1 causes the timekeeping capture, so the bit must be returned to 0 before reading again.							

Maximum Ratings

Exceeding maximum ratings may impair the useful life of the device. These user guidelines are not tested.

- Storage Temperature -65°C to +150°C
- Ambient Temperature with Power Applied -55°C to +150°C
- Supply Voltage on V_{CC} Relative to GND -0.5V to 7.0V
- Voltage Applied to Outputs in High-Z State -0.5V to V_{CC} + 0.5V
- Input Voltage -0.5V to V_{CC}+0.5V
- Transient Voltage (<20 ns) on Any Pin to Ground Potential -2.0V to V_{CC} + 2.0V

- Package Power Dissipation Capability (T_A = 25°C) 1.0W
- Surface Mount Pb Soldering Temperature (3 Seconds) +260°C
- Output Short Circuit Current^[8] 15 mA
- Static Discharge Voltage > 2001V (per MIL-STD-883, Method 3015)
- Latch Up Current > 200 mA

Operating Range

Range	Ambient Temperature	V _{CC}
Commercial	0°C to +70°C	4.5V to 5.5V
Industrial	-40°C to +85°C	4.5V to 5.5V

DC Electrical Characteristics

Over the Operating Range (V_{CC} = 4.5V to 5.5V) ^[10]

Parameter	Description	Test Conditions	Min	Max	Unit
I _{CC1}	Average V _{CC} Current	t _{RC} = 15 ns	Commercial	70	mA
		t _{RC} = 20 ns		65	mA
		t _{RC} = 25 ns		65	mA
		t _{RC} = 45 ns		50	mA
		Dependent on output loading and cycle rate. Values obtained without output loads. I _{OUT} = 0 mA	Industrial	75	mA
				70	mA
				70	mA
				52	mA
I _{CC2}	Average V _{CC} Current during STORE	All Inputs Don't Care, V _{CC} = Max. Average current for duration t _{STORE}		6	mA
I _{CC3} ^[9]	Average V _{CC} Current at t _{RC} = 200 ns, 5V, 25°C typical	WE > (V _{CC} - 0.2). All other I/P cycling. Dependent on output loading and cycle rate. Values obtained without output loads.		35	mA
I _{CC4}	Average V _{CAP} Current during AutoStore Cycle	All Inputs Don't Care, V _{CC} = Max. Average current for duration t _{STORE}		6	mA
I _{SB}	V _{CC} Standby Current	CE > (V _{CC} - 0.2). All others V _{IN} < 0.2V or > (V _{CC} - 0.2V). Standby current level after nonvolatile cycle is complete. Inputs are static. f = 0MHz.		3	mA
I _{IX}	Input Leakage Current (except HSB)	V _{CC} = Max, V _{SS} ≤ V _{IN} ≤ V _{CC}	-1	+1	μA
	Input Leakage Current (for HSB)	V _{CC} = Max, V _{SS} ≤ V _{IN} ≤ V _{CC}	-100	+1	μA
I _{OZ}	Off State Output Leakage Current	V _{CC} = Max., V _{IN} = V _{SS} ≤ V _{IN} ≤ V _{CC} , CE or OE > V _{IH}	-1	+1	μA
V _{IH}	Input HIGH Voltage		2.2	V _{CC} + 0.5	V
V _{IL}	Input LOW Voltage		V _{SS} - 0.5	0.8	V
V _{OL}	Output LOW Voltage	I _{OUT} = 4 mA		0.4	V
V _{OH}	Output HIGH Voltage	I _{OUT} = -2 mA	2.4		V
V _{CAP}	Storage Capacitor	Between V _{CAP} pin and V _{SS} , 5V Rated	61	82	μF

Notes

- 8. Outputs shorted for no more than one second. Only one output is shorted at a time.
- 9. Typical conditions for the active current shown on the front page of the data sheet are average values at 25°C (room temperature), and V_{CC} = 5V. Not 100% tested.
- 10. The HSB pin has I_{OUT} = -10 uA for V_{OH} of 2.4V. This parameter is characterized but not tested.

Capacitance

In the following table, the capacitance parameters are listed. [11]

Parameter	Description	Test Conditions	Max	Unit
C _{IN}	Input Capacitance	T _A = 25°C, f = 1 MHz, V _{CC} = 0 to 3.0V	7	pF
C _{OUT}	Output Capacitance		7	pF

Thermal Resistance

In the following table, the thermal resistance parameters are listed.[11]

Parameter	Description	Test Conditions	44-TSOP II	54-TSOP II	Unit
Θ _{JA}	Thermal Resistance (Junction to Ambient)	Test conditions follow standard test methods and procedures for measuring thermal impedance, in accordance with EIA/JESD51.	31.11	30.73	°C/W
Θ _{JC}	Thermal Resistance (Junction to Case)		5.56	6.08	°C/W

Figure 6. AC Test Loads

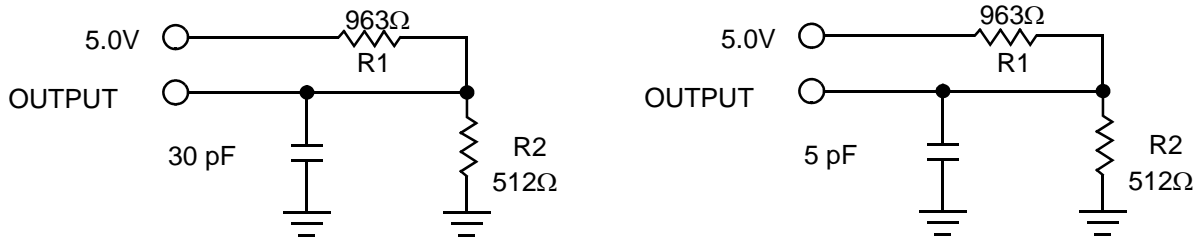

AC Test Conditions

Input Pulse Levels 0V to 3V

Input Rise and Fall Times (10% - 90%) ≤5 ns

Input and Output Timing Reference Levels 1.5V

Table 5. RTC Characteristics

Parameters	Description	Test Conditions		Min	Max	Units
I _{BAK} [12]	RTC Backup Current		Commercial		300	nA
			Industrial		350	nA
V _{RTCbat} [13]	RTC Battery Pin Voltage		Commercial	1.8	3.3	V
			Industrial	1.8	3.3	V
V _{RTCcap} [14]	RTC Capacitor Pin Voltage		Commercial	1.5	3.6	V
			Industrial	1.5	3.6	V
tOCS	RTC Oscillator Time to Start	At Minimum Temperature from Power up or Enable	Commercial		10	sec
		At 25°C Temperature from Power up or Enable	Commercial		5	sec
		At Minimum Temperature from Power up or Enable	Industrial		10	sec
		At 25°C Temperature from Power up or Enable	Industrial		5	sec

Notes

11. These parameters are guaranteed but not tested.

12. From either V_{RTCcap} or V_{RTCbat}.

13. Typical = 3.0V during normal operation.

14. Typical = 2.4V during normal operation.

AC Switching Characteristics

Parameters		Description	15 ns		20 ns		25 ns		45 ns		Unit
Cypress Parameters	Alt Parameters		Min	Max	Min	Max	Min	Max	Min	Max	
SRAM Read Cycle											
t _{ACE}	t _{ACS}	Chip Enable Access Time		15		20		25		45	ns
t _{RC} ^[15]	t _{RC}	Read Cycle Time	15		20		25		45		ns
t _{AA} ^[16]	t _{AA}	Address Access Time		15		20		25		45	ns
t _{DOE}	t _{OE}	Output Enable to Data Valid		10		10		12		20	ns
t _{OHA}	t _{OH}	Output Hold After Address Change	3		3		3		3		ns
t _{LZCE} ^[17]	t _{LZ}	Chip Enable to Output Active	3		3		3		3		ns
t _{HZCE} ^[17]	t _{HZ}	Chip Disable to Output Inactive		7		8		10		15	ns
t _{LZOE} ^[17]	t _{OLZ}	Output Enable to Output Active	0		0		0		0		ns
t _{HZOE} ^[17]	t _{OHZ}	Output Disable to Output Inactive		7		8		10		15	ns
t _{PU} ^[11]	t _{PA}	Chip Enable to Power Active	0		0		0		0		ns
t _{PD} ^[11]	t _{PS}	Chip Disable to Power Standby		15		20		25		45	ns
t _{DBE}	-	Byte Enable to Data Valid		10		10		12		20	ns
t _{LZBE}	-	Byte Enable to Output Active	0		0		0		0		ns
t _{HZBE}	-	Byte Disable to Output Inactive		7		8		10		15	ns
SRAM Write Cycle											
t _{WC}	t _{WC}	Write Cycle Time	15		20		25		45		ns
t _{PWE}	t _{WP}	Write Pulse Width	10		15		20		30		ns
t _{SCE}	t _{CW}	Chip Enable To End of Write	15		15		20		30		ns
t _{SD}	t _{DW}	Data Setup to End of Write	5		8		10		15		ns
t _{HD}	t _{DH}	Data Hold After End of Write	0		0		0		0		ns
t _{AW}	t _{AW}	Address Setup to End of Write	10		15		20		30		ns
t _{SA}	t _{AS}	Address Setup to Start of Write	0		0		0		0		ns
t _{HA}	t _{WR}	Address Hold After End of Write	0		0		0		0		ns
t _{HZWE} ^[17,18]	t _{WZ}	Write Enable to Output Disable		7		8		10		15	ns
t _{LZWE} ^[17]	t _{OW}	Output Active after End of Write	3		3		3		3		ns
t _{BW}	-	Byte Enable to End of Write	15		15		20		30		ns

AutoStore/Power Up RECALL

Parameters	Description	CY14E104K/CY14E104M		Unit
		Min	Max	
t _{HRECALL} ^[19]	Power Up RECALL Duration		20	ms
t _{STORE} ^[20]	STORE Cycle Duration		15	ms
V _{SWITCH}	Low Voltage Trigger Level		4.4	V
t _{VCCRISE}	VCC Rise Time	150		μs

Notes

- 15. WE must be HIGH during SRAM read cycles.
- 16. Device is continuously selected with CE and OE both LOW.
- 17. Measured ±200 mV from steady state output voltage.
- 18. If WE is low when CE goes low, the outputs remain in the high impedance state.
- 19. t_{HRECALL} starts from the time V_{cc} rises above V_{SWITCH}.
- 20. If an SRAM write has not taken place since the last nonvolatile cycle, no STORE takes place.

Software Controlled STORE/RECALL Cycle

In the following table, the software controlled STORE/RECALL cycle parameters are listed.^[21, 22]

Parameters	Description	15 ns		15 ns		25 ns		45 ns		Unit
		Min	Max	Min	Max	Min	Max	Min	Max	
t_{RC}	STORE/RECALL Initiation Cycle Time	15		20		25		45		ns
t_{AS}	Address Setup Time	0		0		0		0		ns
t_{CW}	Clock Pulse Width	12		15		20		30		ns
t_{GHAX}	Address Hold Time	1		1		1				ns
t_{RECALL}	RECALL Duration		200		200		200		200	μ s
t_{SS} ^[23,24]	Soft Sequence Processing Time		70		70		70		70	μ s

Hardware STORE Cycle

Parameters	Description	CY14E104K/CY14E104M		Unit
		Min	Max	
t_{DELAY} ^[25]	Time Allowed to Complete SRAM Cycle	1	70	μ s
t_{HLHX}	Hardware STORE Pulse Width	15		ns

Switching Waveforms

Figure 7. SRAM Read Cycle #1: Address Controlled^[15, 16, 26]

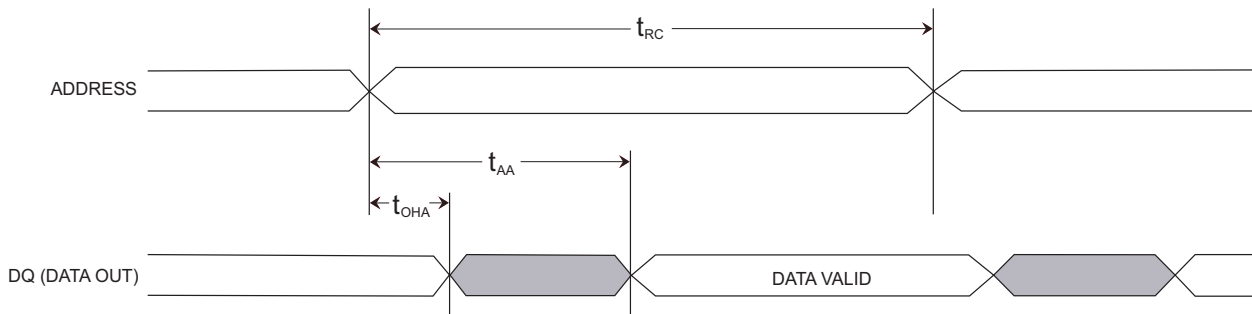

Notes

- 21. The software sequence is clocked with \overline{CE} controlled or \overline{OE} controlled reads.
- 22. The six consecutive addresses must be read in the order listed in Table 1 on page 5. \overline{WE} must be HIGH during all six consecutive cycles.
- 23. This is the amount of time it takes to take action on a soft sequence command. V_{CC} power must remain HIGH to effectively register command.
- 24. Commands such as STORE and RECALL lock out IO until operation is complete which further increases this time. See specific command.
- 25. On a hardware STORE initiation, SRAM operation continues to be enabled for time t_{DELAY} to allow read and write cycles to complete.
- 26. HSB must remain HIGH during read and write cycles.

Switching Waveforms (continued)

Figure 8. SRAM Read Cycle #2: \overline{CE} Controlled^[15, 26, 28]

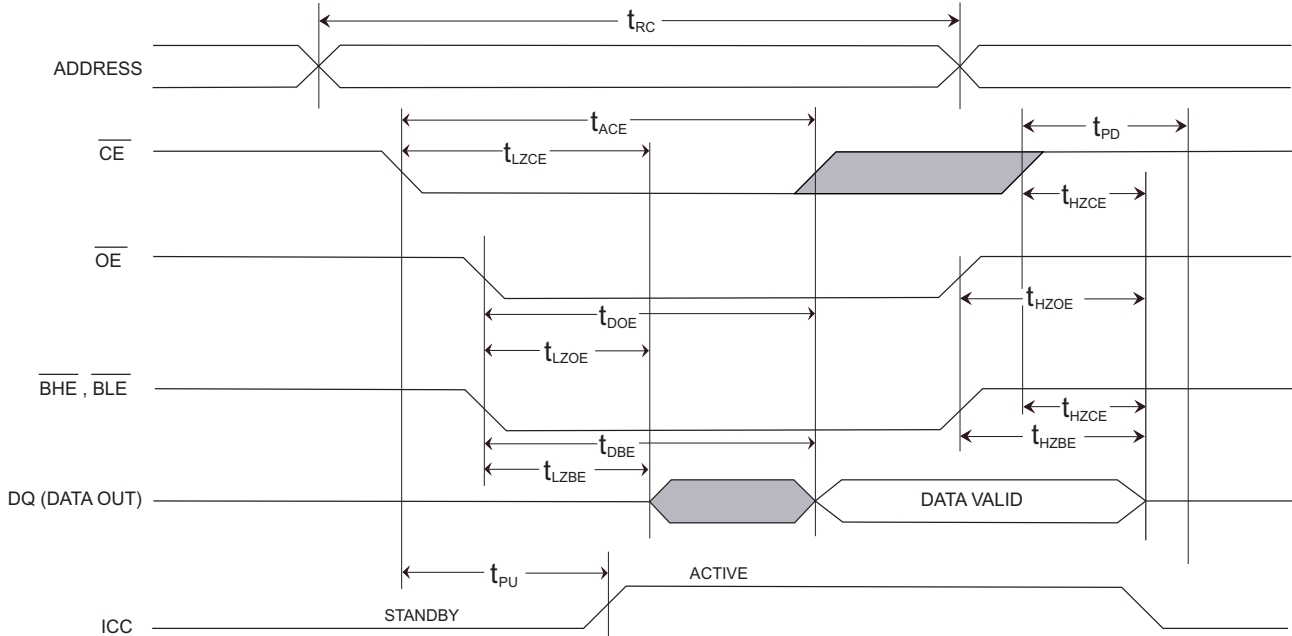
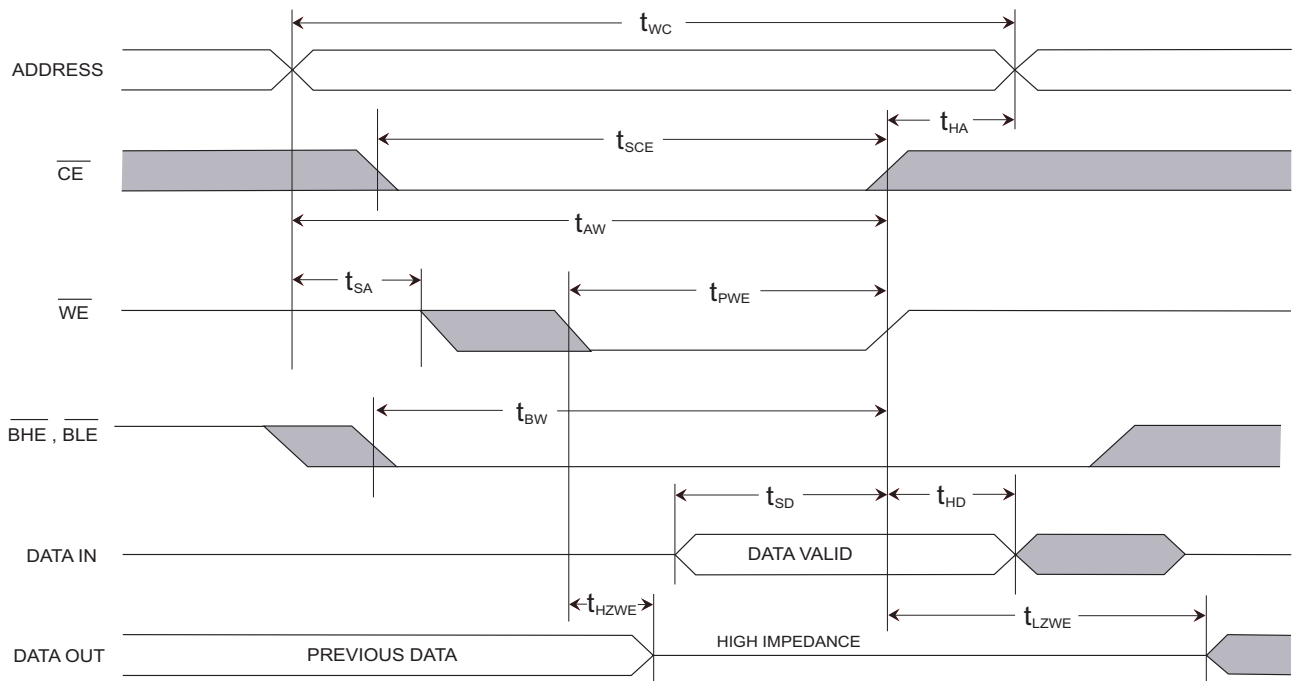

Figure 9. SRAM Write Cycle #1: \overline{WE} Controlled^[18, 26, 27, 28]



Notes

- 27. \overline{CE} or \overline{WE} must be $\geq V_{IH}$ during address transitions.
- 28. \overline{BHE} and \overline{BLE} are applicable for x16 configuration only.

Switching Waveforms (continued)

Figure 10. SRAM Write Cycle #2: $\overline{\text{CE}}$ Controlled^[18, 26, 27, 28]

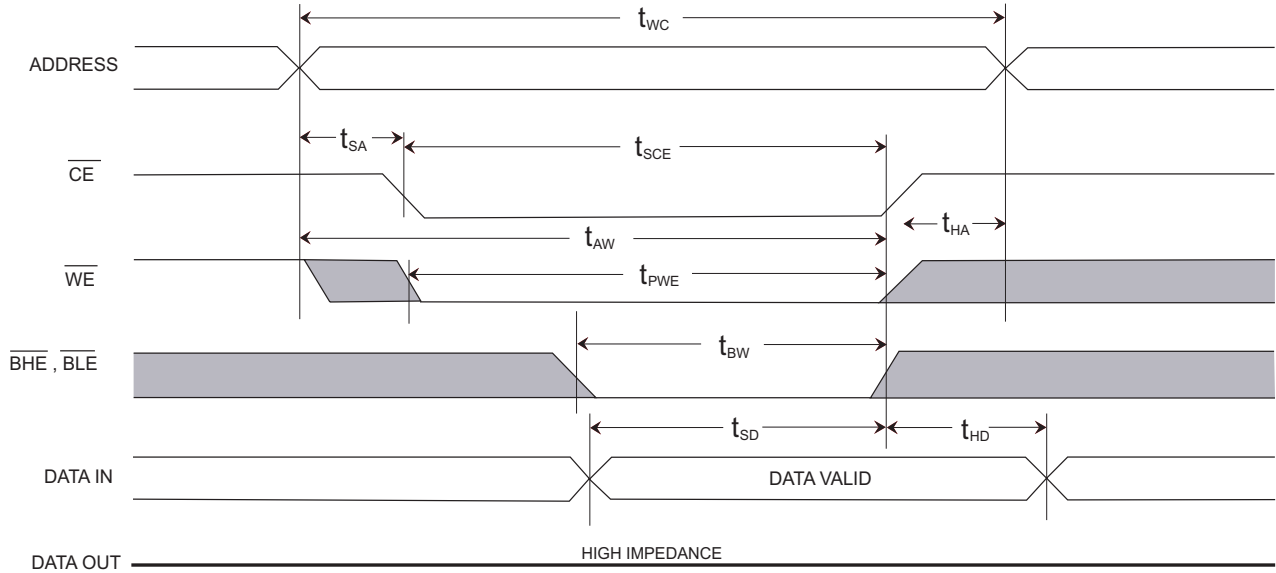
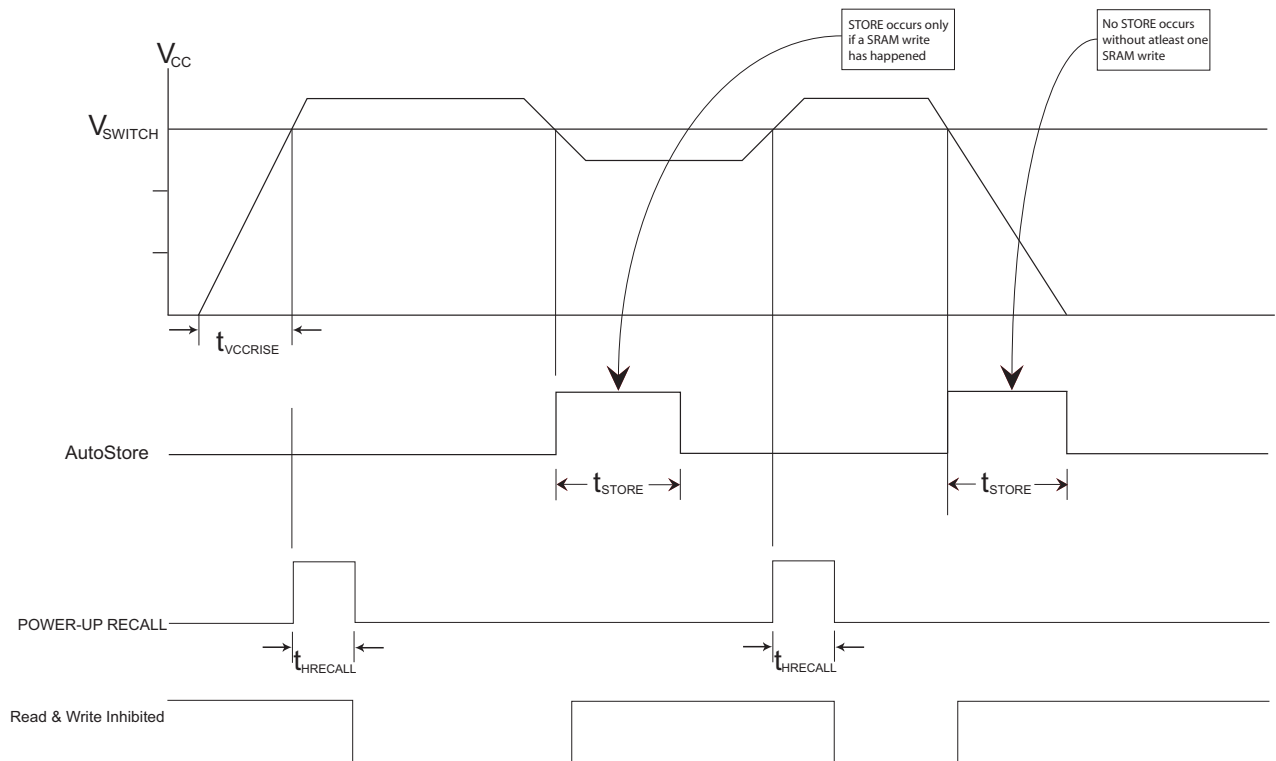

Figure 11. AutoStore/Power Up RECALL



Note

29. Read and Write cycles are ignored during STORE, RECALL, and while VCC is below V_{SWITCH} .

Switching Waveforms (continued)

Figure 12. $\overline{\text{CE}}$ Controlled Software STORE/RECALL Cycle^[22]

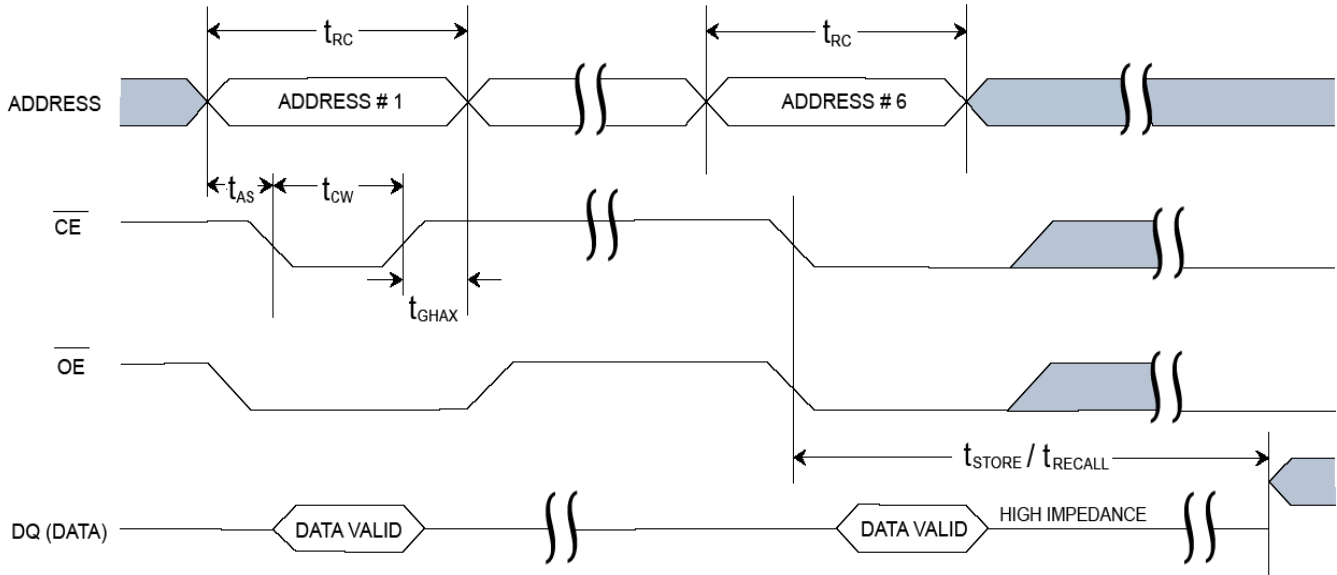
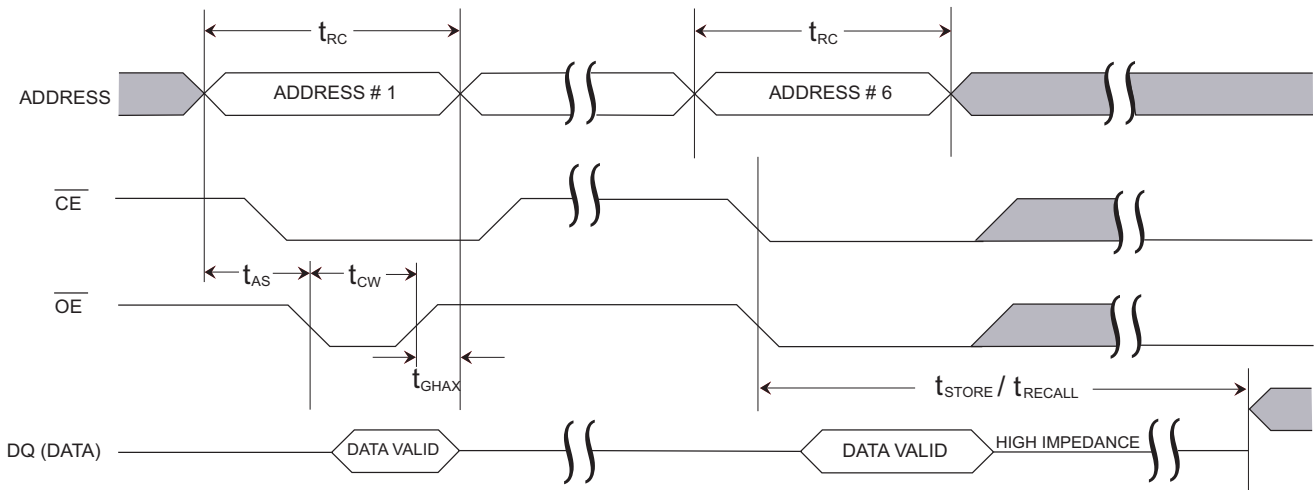

Figure 13. $\overline{\text{OE}}$ Controlled Software STORE/RECALL Cycle^[22]



Switching Waveforms (continued)

Figure 14. Hardware STORE Cycle^[25]

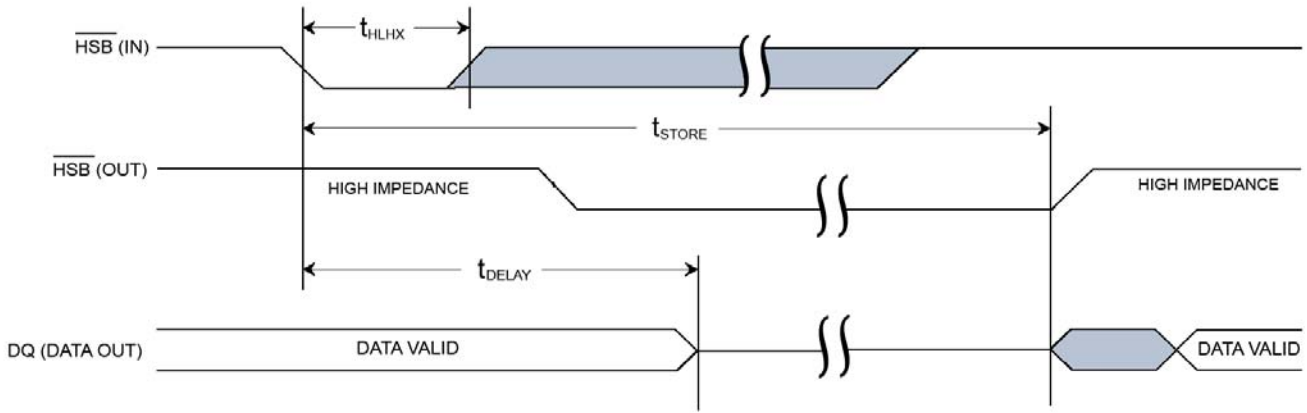
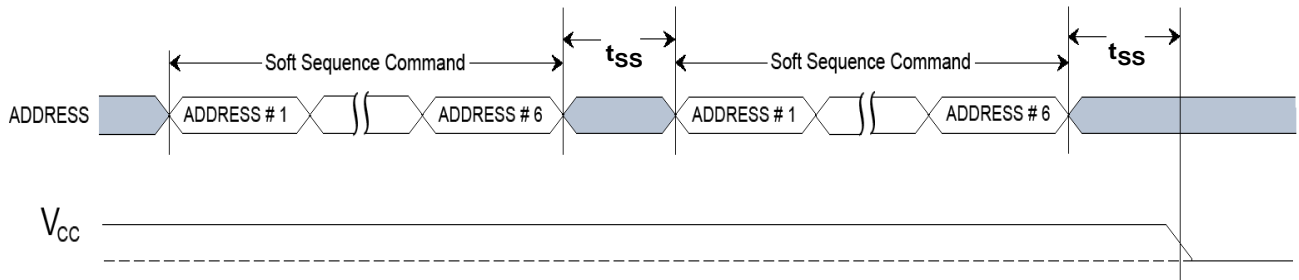
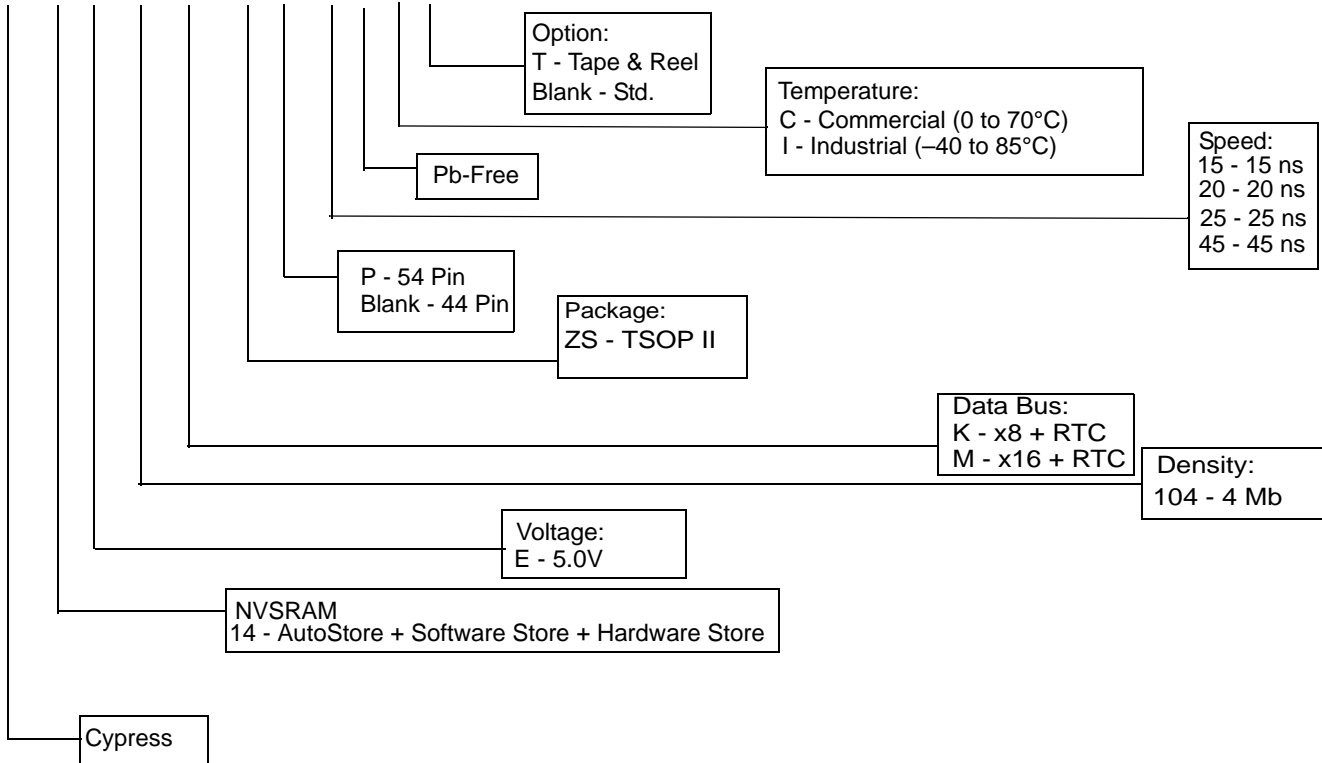

Figure 15. Soft Sequence Processing^[23, 24]



PART NUMBERING NOMENCLATURE

CY 14 E 104 K - ZS P 15 X C T



Ordering Information

Speed (ns)	Ordering Code	Package Diagram	Package Type	Operating Range
15	CY14E104K-ZS15XCT	51-85087	44-pin TSOPII	Commercial
	CY14E104K-ZS15XIT	51-85087	44-pin TSOPII	Industrial
	CY14E104K-ZS15XI	51-85087	44-pin TSOPII	
	CY14E104M-ZS15XCT	51-85087	44-pin TSOPII	Commercial
	CY14E104M-ZS15XIT	51-85087	44-pin TSOPII	Industrial
	CY14E104M-ZS15XI	51-85087	44-pin TSOPII	
	CY14E104K-ZSP15XCT	51-85160	54-pin TSOPII	Commercial
	CY14E104K-ZSP15XIT	51-85160	54-pin TSOPII	Industrial
	CY14E104K-ZSP15XI	51-85160	54-pin TSOPII	
	CY14E104M-ZSP15XCT	51-85160	54-pin TSOPII	Commercial
	CY14E104M-ZSP15XIT	51-85160	54-pin TSOPII	Industrial
	CY14E104M-ZSP15XI	51-85160	54-pin TSOPII	
20	CY14E104K-ZS20XCT	51-85087	44-pin TSOPII	Commercial
	CY14E104K-ZS20XIT	51-85087	44-pin TSOPII	Industrial
	CY14E104K-ZS20XI	51-85087	44-pin TSOPII	
	CY14E104M-ZS20XCT	51-85087	44-pin TSOPII	Commercial
	CY14E104M-ZS20XIT	51-85087	44-pin TSOPII	Industrial
	CY14E104M-ZS20XI	51-85087	44-pin TSOPII	
	CY14E104K-ZSP20XCT	51-85160	54-pin TSOPII	Commercial
	CY14E104K-ZSP20XIT	51-85160	54-pin TSOPII	Industrial
	CY14E104K-ZSP20XI	51-85160	54-pin TSOPII	
	CY14E104M-ZSP20XCT	51-85160	54-pin TSOPII	Commercial
	CY14E104M-ZSP20XIT	51-85160	54-pin TSOPII	Industrial
	CY14E104M-ZSP20XI	51-85160	54-pin TSOPII	
25	CY14E104K-ZS25XCT	51-85087	44-pin TSOPII	Commercial
	CY14E104K-ZS25XIT	51-85087	44-pin TSOPII	Industrial
	CY14E104K-ZS25XI	51-85087	44-pin TSOPII	
	CY14E104M-ZS25XCT	51-85087	44-pin TSOPII	Commercial
	CY14E104M-ZS25XIT	51-85087	44-pin TSOPII	Industrial
	CY14E104M-ZS25XI	51-85087	44-pin TSOPII	
	CY14E104K-ZSP25XCT	51-85160	54-pin TSOPII	Commercial
	CY14E104K-ZSP25XIT	51-85160	54-pin TSOPII	Industrial
	CY14E104K-ZSP25XI	51-85160	54-pin TSOPII	
	CY14E104M-ZSP25XCT	51-85160	54-pin TSOPII	Commercial
	CY14E104M-ZSP25XIT	51-85160	54-pin TSOPII	Industrial
	CY14E104M-ZSP25XI	51-85160	54-pin TSOPII	

Ordering Information (continued)

Speed (ns)	Ordering Code	Package Diagram	Package Type	Operating Range
45	CY14E104K-ZS45XCT	51-85087	44-pin TSOPII	Commercial
	CY14E104K-ZS45XIT	51-85087	44-pin TSOPII	Industrial
	CY14E104K-ZS45XI	51-85087	44-pin TSOPII	
	CY14E104M-ZS45XCT	51-85087	44-pin TSOPII	Commercial
	CY14E104M-ZS45XIT	51-85087	44-pin TSOPII	Industrial
	CY14E104M-ZS45XI	51-85087	44-pin TSOPII	
	CY14E104K-ZSP45XCT	51-85160	54-pin TSOPII	Commercial
	CY14E104K-ZSP45XIT	51-85160	54-pin TSOPII	Industrial
	CY14E104K-ZSP45XI	51-85160	54-pin TSOPII	
	CY14E104M-ZSP45XCT	51-85160	54-pin TSOPII	Commercial
	CY14E104M-ZSP45XIT	51-85160	54-pin TSOPII	Industrial
	CY14E104M-ZSP45XI	51-85160	54-pin TSOPII	

All parts are Pb-free. The above table contains Preliminary information. Please contact your local Cypress sales representative for availability of these parts.

Package Diagrams

Figure 16. 44-Pin TSOP II (51-85087)

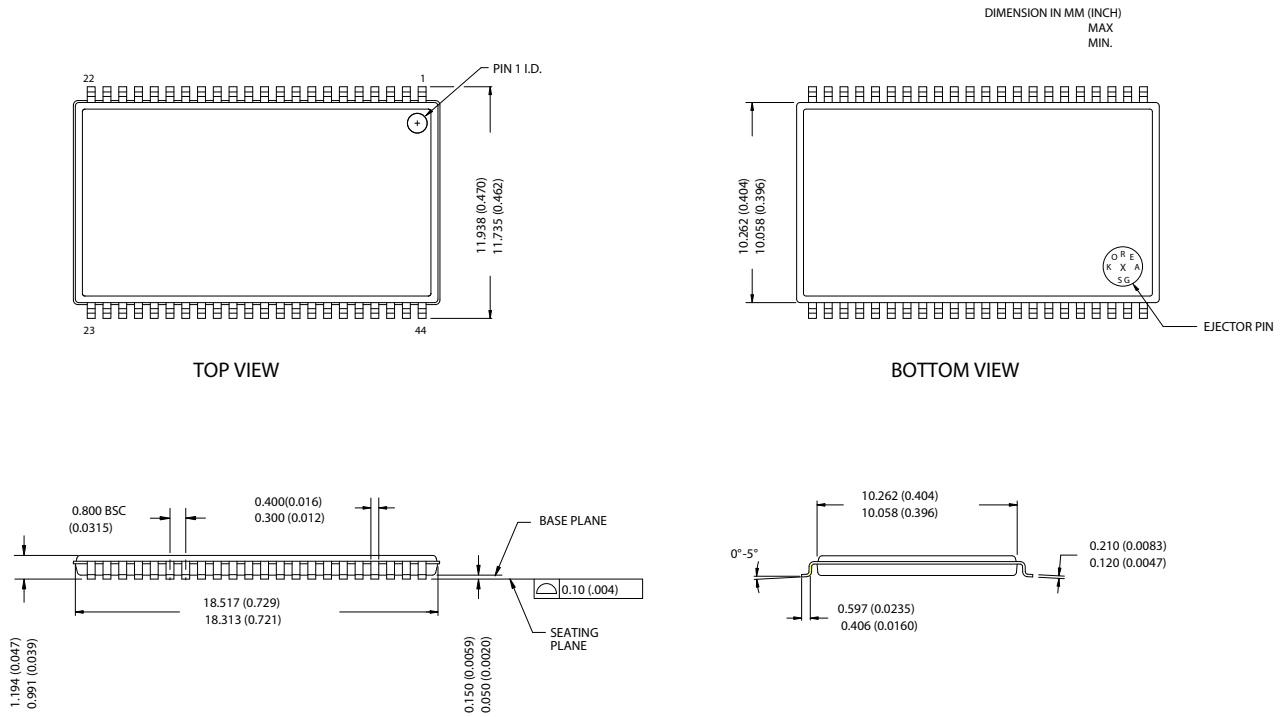

51-85087-*A

Document History Page

Document Title: CY14E104K/CY14E104M 4 Mbit (512K x 8 / 256K x 16) nvSRAM with Real-Time-Clock Document Number: 001-09604				
Rev.	ECN No.	Submission Date	Orig. of Change	Description of Change
**	493192	See ECN	TUP	New Data Sheet
*A	499597	See ECN	PCI	Removed 35 ns speed bin. Added 55 ns speed bin. Updated AC table for the same. Changed "Unlimited" read/write to "infinite" read/write Features section: Changed typical I _{CC} at 200-ns cycle time to 8 mA Changed STORE cycles from 500K to 200K cycles. Shaded Commercial grade in operating range table. Modified I _{CC} /I _{SB} specs. Changed V _{CAP} value in DC table Modified part nomenclature table. Changes reflected in the ordering information table.
*B	517928	See ECN	TUP	Removed 55ns speed bin Changed the pinout for 44TSOPII and 54TSOPII packages Changed I _{SB} to 1mA. Changed I _{CC4} to 3mA Changed t _{STORE} to 15ns. Changed t _{PWE} to 10ns Changed t _{SCE} to 15ns. Changed t _{SD} to 5ns Changed t _{AW} to 10ns. Removed t _{HLBL} Added Timing Parameters for BHE and BLE - t _{DBE} , t _{LZBE} , t _{HZBE} , t _{BW} Removed min. specification for Vswitch Changed t _{GLAX} to 1ns. Added t _{DELAY} max. of 70us Changed t _{SS} specification from 70us min. to 70us max.
*C	774157	See ECN	UHA	Changed the data sheet from Advance information to Preliminary Changed t _{DBE} to 10ns in 15ns part Changed t _{HZBE} in 15ns part to 7ns and in 25ns part to 10ns Changed t _{BW} in 15ns part to 15ns and in 25ns part to 20ns Changed t _{GLAX} to t _{GHAX} Changed the value of I _{CC3} to 25mA Changed the value of t _{AW} to 15ns in 15ns part Changed Note 1 to include 16Mbit In AC test loads changed the value of R1 to 963Ω and R2 to 512Ω
*D	914280	See ECN	UHA	Changed the figure-14 title from 54-Pb to 54 Pin Included all the information for 45ns part in this data sheet
*E	1890926	See ECN	vsutmp8 /AESA	Updated logic block diagram Added Footnote 1, 2 and 3. Updated Pin definition table Changed 8Mb Address expansion Pin from Pin 43 to Pin 42 for 44-TSOP II (x8). Corrected typo in V _{IL} min spec Changed Vswitch value from 2.65V to 4.4V Changed the value of I _{CC3} from 25mA to 13mA Changed I _{SB} value from 1mA to 2mA updated ordering information table Changed package diagrams title The pins X1 and X2 interchanged in 44TSOP II(x8) and 54TSOP II(x16) pinout.
*F	2267286	See ECN	GVCH/ PYRS	Rearranging of "Features". Updated Figure 2 (Autostore mode) RTC Register Map: Register 0x1FFF6: Changed D4 from ABE to 0 Register Map Detail: 0x1FFF6: Changed D4 from ABE to 0 and removed ABE Info Changed I _{CC2} & I _{CC4} from 3mA to 6mA. Changed I _{CC3} from 13mA to 15mA Changed I _{SB} from 2mA to 3mA Added input leakage current (I _{IX}) for HSB in DC Electrical Characteristics table Changed Vcap from 35uF min and 57uF max value to 54uF min and 82uF max value Changed Vrtccap max from 2.7V to 3.6V. Changed t _{RECALL} from 100 to 200us 45ns speed information is added in Software Controlled Store/Recall Cycle Table Corrected typo in t _{AW} value from 15ns to 10ns for 15ns part Reframed footnote 6, 18 and 25. Added footnote 29 Added footnote 18 to figure 8 and footnote 18, 26 and 27 to figure 9.

Document Title: CY14E104K/CY14E104M 4 Mbit (512K x 8 / 256K x 16) nvSRAM with Real-Time-Clock
Document Number: 001-09604

Rev.	ECN No.	Submission Date	Orig. of Change	Description of Change
*G	2483627	See ECN	GVCH/ PYRS	Removed 8 mA typical I _{CC} at 200 ns cycle time in Feature section Referenced footnote 9 to I _{CC3} in DC Characteristics table Changed I _{CC3} from 15 mA to 35 mA Changed V _{cap} minimum value from 54 uF to 61 uF Changed t _{AVAV} to t _{RC} . Changed V _{RTCCap} minimum value from 1.2V to 1.5V Figure 12: Changed t _{SA} to t _{AS} and t _{SCE} to t _{CW}
*H	2519319	06/20/08	GVCH/ PYRS	Added 20 ns access speed in "Features" Added I _{CC1} for t _{RC} =20 ns for both industrial and Commercial temperature Grade Updated thermal resistance values for 44-TSOP II and 54-TSOP II packages Added AC Switching Characteristics specs for 20 ns access speed Added Software controlled STORE/RECALL cycle specs for 20 ns access speed Updated ordering information and Part numbering nomenclature

Sales, Solutions, and Legal Information

Worldwide Sales and Design Support

Cypress maintains a worldwide network of offices, solution centers, manufacturer’s representatives, and distributors. To find the office closest to you, visit us at cypress.com/sales.

Products

- PSoC psoc.cypress.com
- Clocks & Buffers clocks.cypress.com
- Wireless wireless.cypress.com
- Memories memory.cypress.com
- Image Sensors image.cypress.com

PSoC Solutions

- General psoc.cypress.com/solutions
- Low Power/Low Voltage psoc.cypress.com/low-power
- Precision Analog psoc.cypress.com/precision-analog
- LCD Drive psoc.cypress.com/lcd-drive
- CAN 2.0b psoc.cypress.com/can
- USB psoc.cypress.com/usb

© Cypress Semiconductor Corporation, 2006-2008. The information contained herein is subject to change without notice. Cypress Semiconductor Corporation assumes no responsibility for the use of any circuitry other than circuitry embodied in a Cypress product. Nor does it convey or imply any license under patent or other rights. Cypress products are not warranted nor intended to be used for medical, life support, life saving, critical control or safety applications, unless pursuant to an express written agreement with Cypress. Furthermore, Cypress does not authorize its products for use as critical components in life-support systems where a malfunction or failure may reasonably be expected to result in significant injury to the user. The inclusion of Cypress products in life-support systems application implies that the manufacturer assumes all risk of such use and in doing so indemnifies Cypress against all charges.

Any Source Code (software and/or firmware) is owned by Cypress Semiconductor Corporation (Cypress) and is protected by and subject to worldwide patent protection (United States and foreign), United States copyright laws and international treaty provisions. Cypress hereby grants to licensee a personal, non-exclusive, non-transferable license to copy, use, modify, create derivative works of, and compile the Cypress Source Code and derivative works for the sole purpose of creating custom software and or firmware in support of licensee product to be used only in conjunction with a Cypress integrated circuit as specified in the applicable agreement. Any reproduction, modification, translation, compilation, or representation of this Source Code except as specified above is prohibited without the express written permission of Cypress.

Disclaimer: CYPRESS MAKES NO WARRANTY OF ANY KIND, EXPRESS OR IMPLIED, WITH REGARD TO THIS MATERIAL, INCLUDING, BUT NOT LIMITED TO, THE IMPLIED WARRANTIES OF MERCHANTABILITY AND FITNESS FOR A PARTICULAR PURPOSE. Cypress reserves the right to make changes without further notice to the materials described herein. Cypress does not assume any liability arising out of the application or use of any product or circuit described herein. Cypress does not authorize its products for use as critical components in life-support systems where a malfunction or failure may reasonably be expected to result in significant injury to the user. The inclusion of Cypress’ product in a life-support systems application implies that the manufacturer assumes all risk of such use and in doing so indemnifies Cypress against all charges.

Use may be limited by and subject to the applicable Cypress software license agreement.