

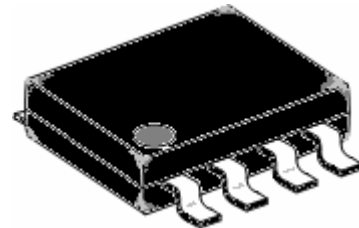

White LED Cup Light Controller

Features

- Precision reference voltage: 0.5V ($\pm 2\%$)
- Wide operation input voltage: 3.0V ~ 18V
- High output loading current: typ. 2.0A
- Fixed PWM frequency: typ. 360KHz
- Programmable soft-start
- Thermal shutdown and short circuit protection
- Compensation and ON/OFF control
- Package: SOP8



General Description

The **MR163**, a 1-chip composed of high current MOS with a fixed PWM oscillator and an error amplifier with a 0.5V precision voltage reference for LED current feedback and driving capability, applied to offer space and low cost in many applications such as the DC/DC buck converter and serial white LEDs cup light controller and driver.

Typical Application Circuit

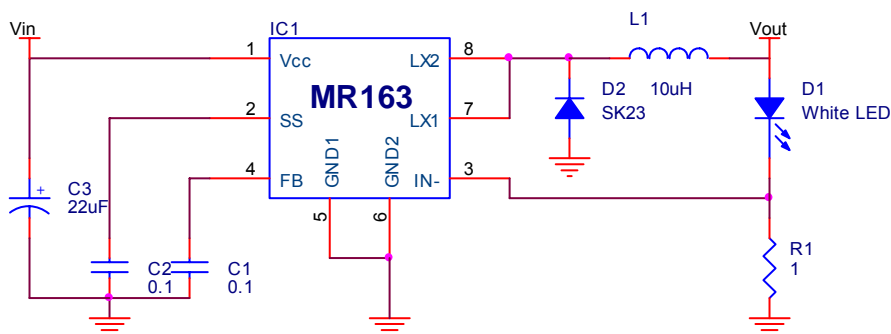

High-Brightness White LED Cup Application Example



MR163 Functional Block Diagram

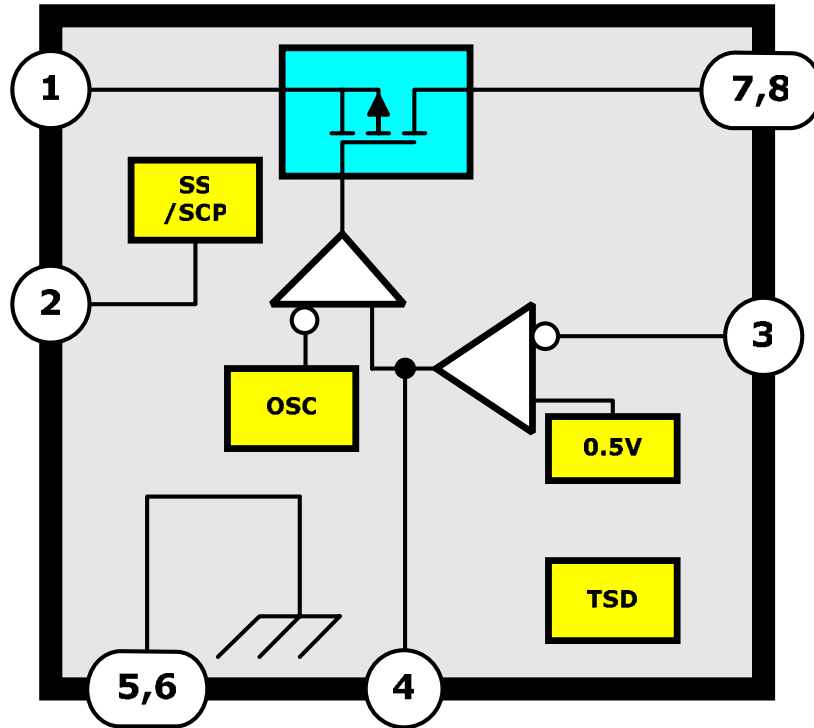

MARK VIEW

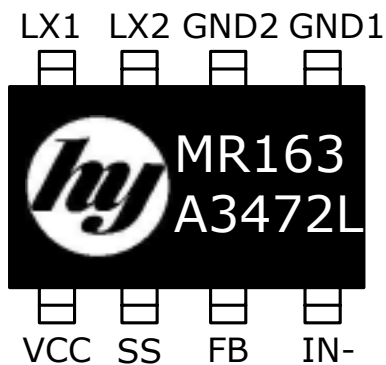

PIN DESCRIPTION

NAME	STATUS	DESCRIPTION
VCC	P	IC Power Supply
SS	I	Soft-Start / SCP Control Input
IN-	I	Negative Feedback Input
FB	I	Compensation Input (On/Off)
GND1	P	IC Ground
GND2		
LX1	O	MOS Switching Output
LX2		



IC Date Code Distinguish

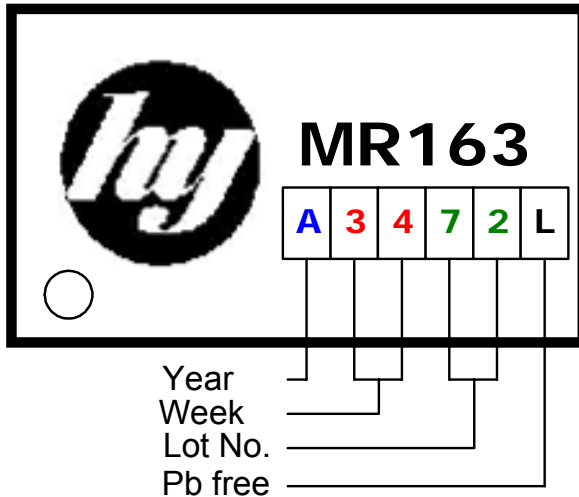

Logo: [Hawyang logo](#)

Product name: **MR163** (for example)

D/C: **A3472**

A – year 2001, **B** – year 2002, **C** – year 2003

34 – week

72 – lot no. last 2 code

Order Information

Part Number	Operating Temperature	Package	Description
MR163DLF	-20 85	SOP8	Tube
MR163DLF(R)	-20 85	SOP8	Tape & Reel



Absolute Maximum Ratings

Symbol	Parameter	Rating
V_{CC}	Supply Voltage	+20 V
V_{FB}	Analog Input Voltage	-0.3 V +1.2V
V_O	LX Output Voltage	+30 V
I_O	Output Current	3 A
T_j	Maximum Junction Temperature	150
SOP package	Thermal Resistance Junction to Ambient	175 /W
SOP8 package	Power Dissipation	
	$T_a=25$ $T_a=70$	650mW 550mW
T_{OPR}	Operating Temperature Range	-20 85
T_{STG}	Storage Temperature Range	-65 150
soldering, 10 sec	Lead Temperature	+260



Electrical Characteristics

Electrical characteristics over recommended operating temperature range, $V_{CC}=6V$, unless otherwise noted

Reference Section

PARAMETER	SYMBOL	TEST CONDITIONS	MIN	TYP	MAX	UNIT
Output voltage	V_{REF}	FB is connected to IN-	0.49	0.5	0.51	V
Input regulation	V_{REF}	$V_{CC} = 3.6 V$ to $20 V$	-	2.0	13	mV
Output voltage change with temperature	V_{REF} / V_{REF}	$T_A = -20$ to 25	-	1	2	%
		$T_A = 25$ to 85	-	1	2	

†All typical values are at $T_A = 25$.

Soft-Start (S.S.) Section

PARAMETER	SYMBOL	TEST CONDITIONS	MIN	TYP	MAX	UNIT
Source Current	I_{SS}	$V_{SS}=0V$	-7	-12	-17	μA
Threshold Voltage	V_{SST}	-	0.9	1.0	1.1	V

†All typical values are at $T_A = 25$.

Short Circuit Protection Section

PARAMETER	SYMBOL	TEST CONDITIONS	MIN	TYP	MAX	UNIT
Source Current	I_{SCP}	$V_{SCP} = 0V$	-7	-12	-17	μA
Threshold Voltage	V_{SCPT}	$V_{FB} > 450mV$	1.0	1.15	1.2	V
ON/OFF time ratio	r	$V_{FB} = 0V$	-	1/20	-	-

†All typical values are at $T_A = 25$.

Thermal Shutdown Section

PARAMETER	SYMBOL	TEST CONDITIONS	MIN	TYP	MAX	UNIT
TSD temperature	TSD	-	-	145	-	



Electrical Characteristics (Cont.)

Error Amplifier Section

PARAMETER	SYMBOL	TEST CONDITIONS	MIN	TYP	MAX	UNIT
Input Bias Current	I_B	-	-1.0	-0.2	1.0	μA
Open Loop Gain	A_{VO}	-	-	40	-	dB
Frequency Bandwidth	F_T	$A_{VO} = 0dB$	-	6	-	MHz
FB Swing Voltage	Positive	V_{OH}	$V_{IN-} = 0.3V$	0.75	0.87	V
	Negative	V_{OL}	$V_{IN-} = 0.7V$		0.05	
FB Source Current	I_{SO}	$V_{FB} = 500mV$	-30	-45		μA
FB Sink Current	I_{SI}		30	45		

†All typical values are at $T_A = 25$.

Idle Period Adjustment Section

PARAMETER	SYMBOL	TEST CONDITIONS	MIN	TYP	MAX	UNIT
Maximum Duty Cycle	T_{DUTY}	$V_{IN-} = 0.2V$	-	90	-	%

Total Device Section

PARAMETER	SYMBOL	TEST CONDITIONS	MIN	TYP	MAX	UNIT
Average Supply Current	I_{AV}	-	-	3	5	mA

Output Power-MOS Section

PARAMETER	SYMBOL	TEST CONDITIONS	MIN	TYP	MAX	UNIT
Breakdown Voltage	V_{DSS}	$V_{FB} = 0.1V$	-	-20	-	V
Source Current	I_{DS}	-	-	-2	-	A
On Resistance	$R_{DS(ON)}$	$V_{CC} = 5.0V, V_{IN-} = 0V$		70	150	$m\Omega$
		$V_{CC} = 10.0V, V_{IN-} = 0V$		42	90	
Leakage Current	$I_{DS(OFF)}$	-		5		μA



Typical Characteristics Curve

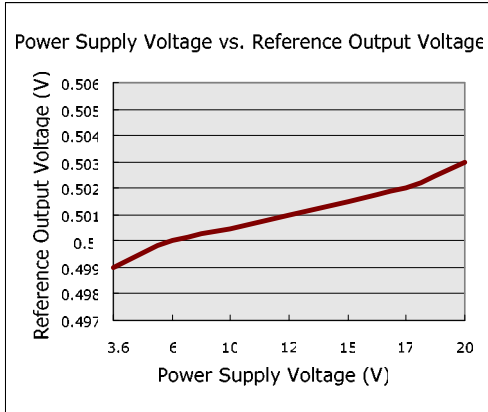

Fig.1

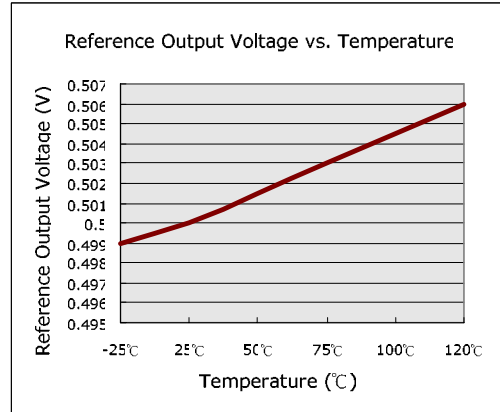

Fig.2

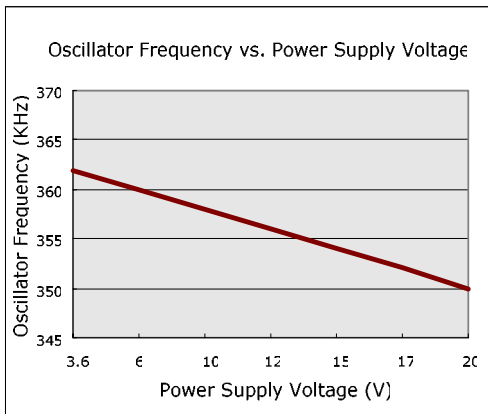

Fig.3

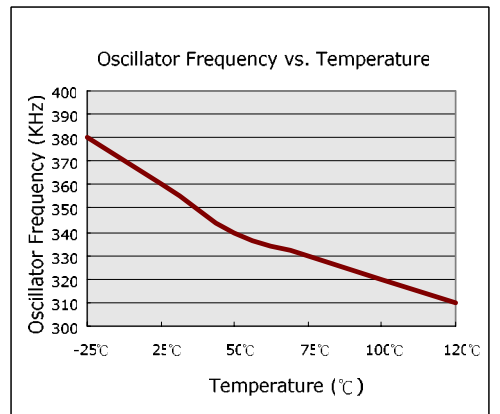

Fig.4

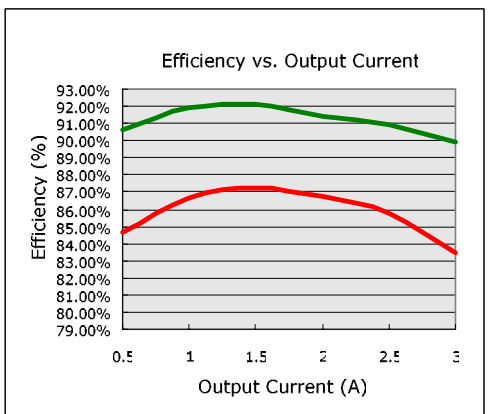

Fig.5

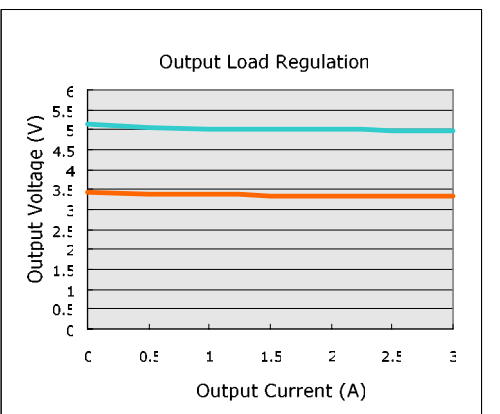

Fig.6



Detailed Description

This is a simple application circuit for a 5W White light LED Application example. The MR163 built-in power-on soft-start function, the time of soft-start is adjusted by C2 capacitor, R1 is current sense for LED, when the sense current time the R1 would generate a sense feedback voltage to IC IN- terminal, IC should turn off LX1 and LX2 and keep L1 energy transfer to Vout and hold the LED lighting until and sense current isn't enough.

C3 and C4 are the capacitors and they keep the supply and Vout voltage smoothly.

It is a few external parts using and reduced PCB space very suitable for a tiny LED light system environment.

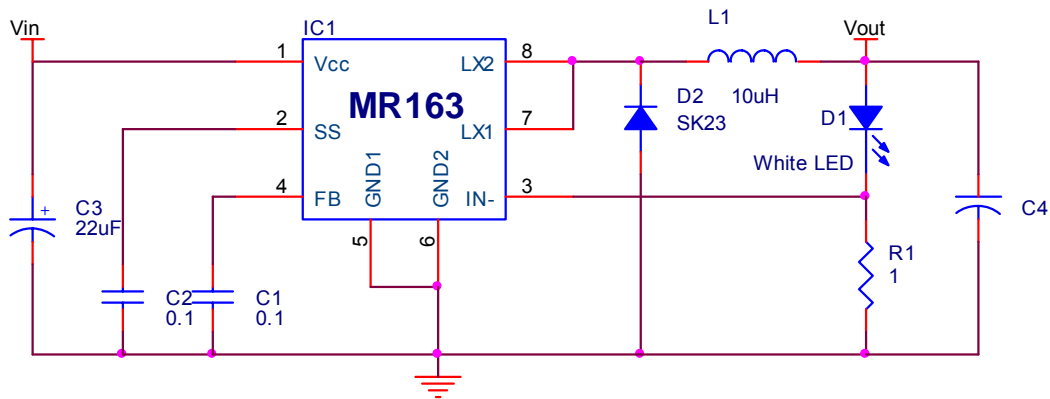
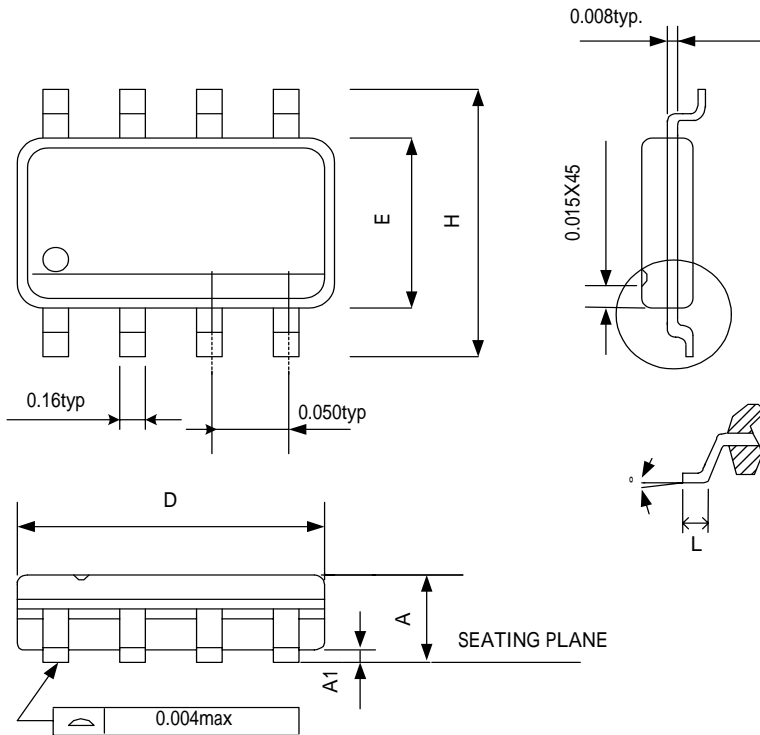

Fig. 7 MR163 Application Circuits



Package outline
SOP 8



NOTE:

1. JEDEC OUTLINE: MS-012 AA

1. DIMENSIONS "D" DOES NOT INCLUDE MOLD FLASH, PROTRUSIONS OR GATE BURRS. MOLD FLASH, PROTRUSIONS AND GATE BURRS SHALL NOT EXCEED .15mm (.06in) PER SIDE

2. DIMENSIONS "E" DOES NOT INCLUDE INTER-LEAD FLASH, OR PROTRUSIONS. INTER-LEAD FLASH AND PROTRUSIONS SHALL NOT EXCEED .25mm (.0.10in) PER SIDE.

SYMBOLS	MIN	MAX
A	0.053	0.069
A1	0.004	0.010
D	0.189	0.196
E	0.150	0.157
H	0.228	0.244
L	0.016	0.050
θ°	0	8



Packing Specifications Box

TUBE INSIDE BOX AND CARTON

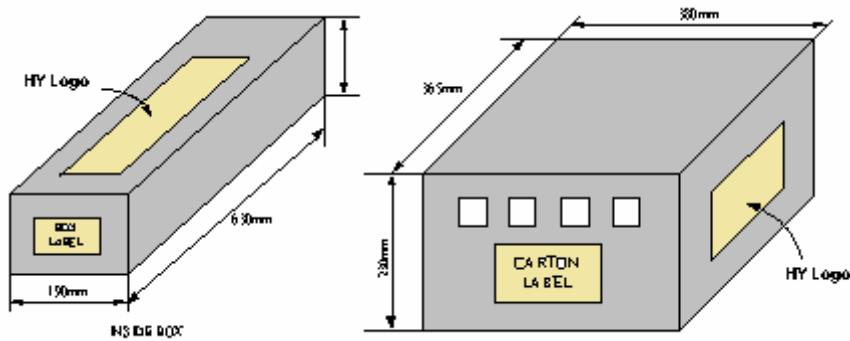

TAPE & REEL INSIDE BOX AND CARTON

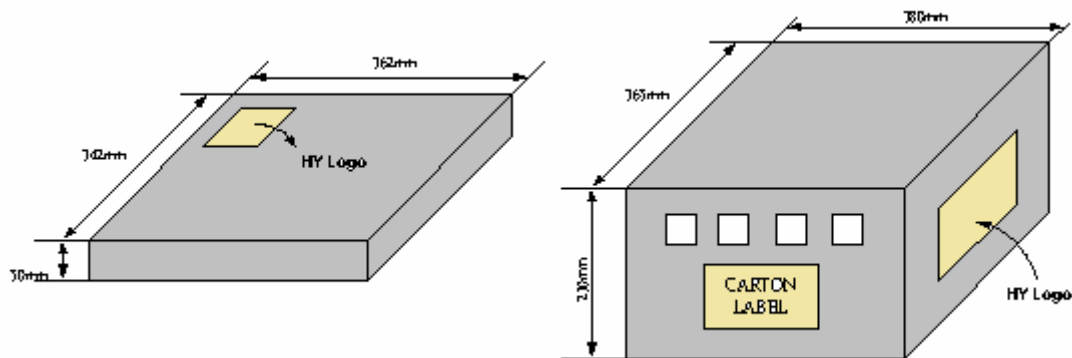

Packing Quantity Specifications

100 EA / TUBE	2500 EA / REEL
100 TUBES / INSIDE BOX	4 INSIDE BOXES / CARTON
4 INSIDE BOXES / CARTON	



Label Specifications



Hawyang Semiconductor Corp.,

Product: MR163DLF(R)

Lot No.: xxxxxxxx

D/C: A3472

Q'ty: 2,500

Carrier Tape Dimensions

APPLICATION	W	P	E	F	D	D ₁
SOP8	12.0 ^{+0.3} _{-0.1}	8.0±0.1	1.75±0.1	5.5±0.1	1.55±0.1	1.5 ^{+0.25}

APPLICATION	P ₀	P ₁	A ₀	B ₀	K ₀	t
SOP8	4.0±0.1	2.0±0.1	6.4±0.1	5.20±0.1	2.1±0.10	0.30±0.013



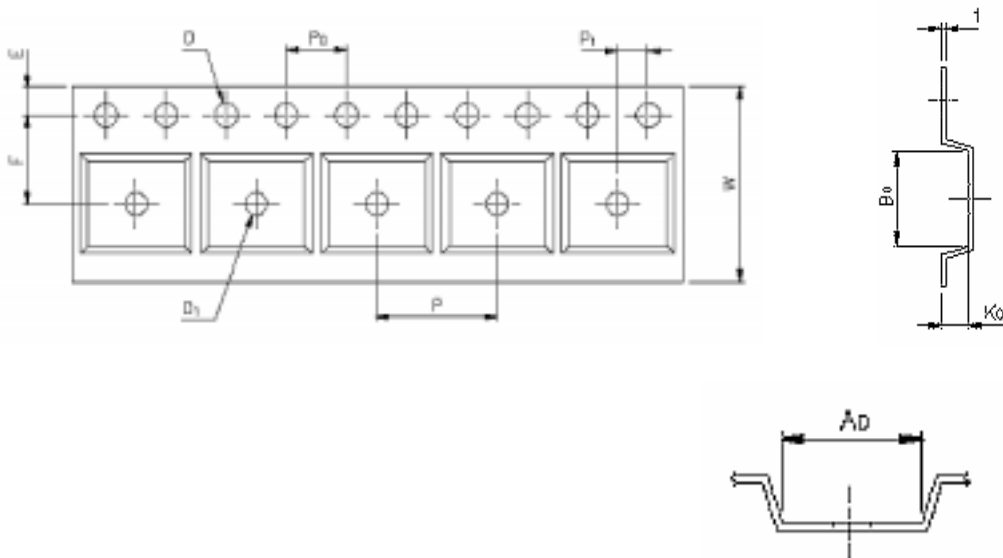

C over Tape Dimensions

CARRIER WIDTH	12	16	24
COVER TAPE WIDTH	9.3	13.3	21.3

(mm)

Reel Dimensions

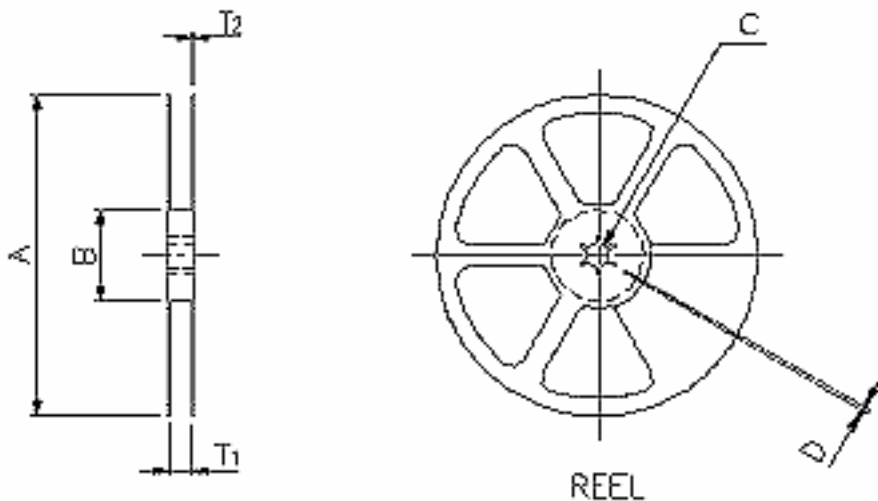

APPLICATION	MATERIAL	A	B	C	D	T ₁	T ₂
SOP8	PLASTIC REEL (WHITE)	330±0.1	62±1.5	12.75+0. 15	2+0.6	12.4+0. 2	2.0+0.2