



STD11NM60N-1 - STB11NM60N/-1 STD11NM60N-STP11NM60N-STF11NM60N

N-channel 600 V - 0.37 Ω - 10 A - TO-220 - TO-220FP- I²PAK - IPAK
DPAK - D²PAK second generation MDmesh™ Power MOSFET

Features

| Type | V _{DSS} (@T _{Jmax}) | R _{DS(on)} max | I _D |
|--------------|---|----------------------------|---------------------|
| STB11NM60N-1 | 650 V | 0.45 Ω | 10 A |
| STB11NM60N | 650 V | 0.45 Ω | 10 A |
| STD11NM60N | 650 V | 0.45 Ω | 10 A |
| STD11NM60N-1 | 650 V | 0.45 Ω | 10 A |
| STF11NM60N | 650 V | 0.45 Ω | 10 A ⁽¹⁾ |
| STP11NM60N | 650 V | 0.45 Ω | 10 A |

1. Limited only by maximum temperature allowed

- 100% avalanche tested
- Low input capacitance and gate charge
- Low gate input resistance

Application

- Switching applications

Description

This series of devices is designed using the second generation of MDmesh™ technology. This revolutionary Power MOSFET associates a new vertical structure to the company's strip layout to yield one of the world's lowest on-resistance and gate charge. It is therefore suitable for the most demanding high efficiency converters.

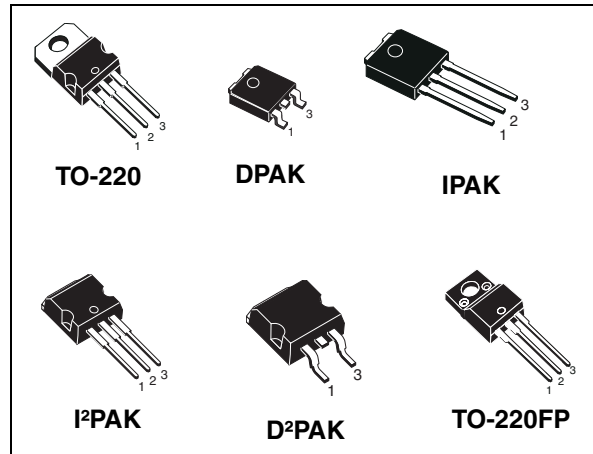

Figure 1. Internal schematic diagram

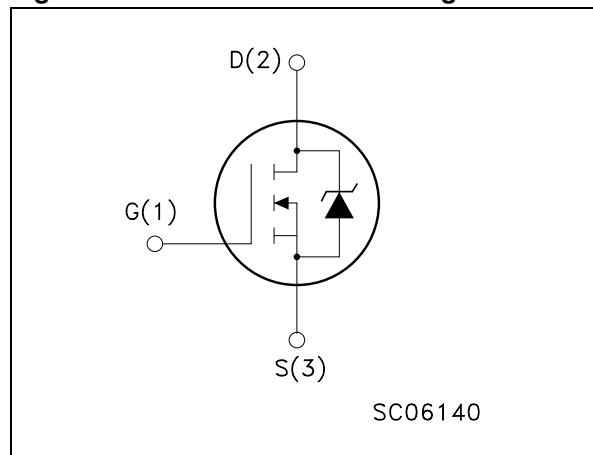

Table 1. Device summary

| Order codes | Marking | Package | Packaging |
|--------------|----------|--------------------|---------------|
| STB11NM60N-1 | B11NM60N | I ² PAK | Tube |
| STB11NM60N | 11NM60N | D ² PAK | Tape and reel |
| STD11NM60N-1 | D11NM60N | IPAK | Tube |
| STD11NM60N | D11NM60N | DPAK | Tape and reel |
| STP11NM60N | P11NM60N | TO-220 | Tube |
| STF11NM60N | F11NM60N | TO-220FP | Tube |

Contents

| | | |
|----------|---|-----------|
| 1 | Electrical ratings | 3 |
| 2 | Electrical characteristics | 4 |
| | 2.1 Electrical characteristics (curves) | 6 |
| 3 | Test circuits | 9 |
| 4 | Package mechanical data | 10 |
| 5 | Packaging mechanical data | 17 |
| 6 | Revision history | 19 |

1 Electrical ratings

Table 2. Absolute maximum ratings

| Symbol | Parameter | Value | | Unit |
|--------------------------------|---|--|--------------------|------|
| | | TO-220/I ² PAK D/D ² PAK/IPAK | TO-220FP | |
| V _{DS} | Drain-source voltage (V _{GS} = 0) | 600 | | V |
| V _{GS} | Gate-source voltage | ± 25 | | V |
| I _D | Drain current (continuous) at T _C = 25 °C | 10 | 10 ⁽¹⁾ | A |
| I _D | Drain current (continuous) at T _C = 100 °C | 6.3 | 6.3 ⁽¹⁾ | A |
| I _{DM} ⁽²⁾ | Drain current (pulsed) | 40 | 40 ⁽¹⁾ | A |
| P _{TOT} | Total dissipation at T _C = 25 °C | 90 | 25 | W |
| | Derating factor | 0.8 | 0.2 | W/°C |
| dv/dt ⁽³⁾ | Peak diode recovery voltage slope | 15 | | V/ns |
| V _{ISO} | Insulation withstand voltage (RMS) from all three leads to external heat sink (t = 1 s; T _C = 25 °C) | -- | 2500 | V |
| T _{stg} | Storage temperature | -55 to 150 | | °C |
| T _J | Max. operating junction temperature | 150 | | °C |

1. Limited only by maximum temperature allowed
2. Pulse width limited by safe operating area
3. I_{SD} ≤ 10 A, di/dt ≤ 400 A/μs, V_{DD} = 80% V_{(BR)DSS}

Table 3. Thermal data

| Symbol | Parameter | Value | | | | | | Unit |
|-----------------------|---|--------|--------------------|------|--------------------|------|----------|------|
| | | TO-220 | I ² PAK | DPAK | D ² PAK | IPAK | TO-220FP | |
| R _{thj-case} | Thermal resistance junction-case max | 1.38 | | | | | 5 | °C/W |
| R _{thj-amb} | Thermal resistance junction-amb max | 62.5 | -- | -- | 100 | 62.5 | °C/W | |
| R _{thj-pcb} | Thermal resistance junction-pcb max | -- | -- | 50 | 30 | -- | °C/W | |
| T _I | Maximum lead temperature for soldering purposes | 300 | | | | | | °C |

Table 4. Avalanche characteristics

| Symbol | Parameter | Max value | Unit |
|----------|---|-----------|------|
| I_{AS} | Avalanche current, repetitive or not-repetitive (pulse width limited by T_J max) | 3.5 | A |
| E_{AS} | Single pulse avalanche energy (starting $T_J = 25\text{ °C}$, $I_D = I_{AS}$, $V_{DD} = 50\text{ V}$) | 200 | mJ |

2 Electrical characteristics

(T_{CASE}=25°C unless otherwise specified)

Table 5. On/off states

| Symbol | Parameter | Test conditions | Min. | Typ. | Max. | Unit |
|----------------------|---|---|------|------|---------|----------|
| V _{(BR)DSS} | Drain-source breakdown voltage | I _D = 1 mA, V _{GS} = 0 | 600 | | | V |
| dv/dt ⁽¹⁾ | Drain-source voltage slope | V _{DD} = 400 V, I _D = 5 A, V _{GS} = 10 V | 45 | | | V/ns |
| I _{DSS} | Zero gate voltage drain current (V _{GS} = 0) | V _{DS} = Max rating, V _{DS} =Max rating, T _c =125 °C | | | 1 10 | μA μA |
| I _{GSS} | Gate body leakage current (V _{DS} = 0) | V _{GS} = ±20 V | | | ±100 | nA |
| V _{GS(th)} | Gate threshold voltage | V _{DS} = V _{GS} , I _D = 250 μA | 2 | 3 | 4 | V |
| R _{DS(on)} | Static drain-source on resistance | V _{GS} = 10 V, I _D = 5 A | | 0.37 | 0.45 | Ω |

1. Characteristic value at turn off on inductive load

Table 6. Dynamic

| Symbol | Parameter | Test conditions | Min. | Typ. | Max. | Unit |
|--|---|---|------|-------------------|------|----------------|
| g _{fs} ⁽¹⁾ | Forward transconductance | V _{DS} = 15 V, I _D = 5 A | | 7.5 | | S |
| C _{iss} C _{oss} C _{rss} | Input capacitance Output capacitance Reverse transfer capacitance | V _{DS} = 50 V, f = 1 MHz, V _{GS} = 0 | | 850 44 5 | | pF pF pF |
| C _{oss eq.} ⁽²⁾ | Equivalent output capacitance | V _{GS} = 0, V _{DS} = 0 to 480 V | | 130 | | pF |
| R _g | Gate input resistance | f = 1 MHz Gate DC Bias = 0 Test signal level = 20 mV open drain | | 3.7 | | Ω |
| Q _g Q _{gs} Q _{gd} | Total gate charge Gate-source charge Gate-drain charge | V _{DD} = 480 V, I _D = 10 A V _{GS} = 10 V (see Figure 19) | | 31 4.2 15.9 | | nC nC nC |

1. Pulsed: pulse duration = 300μs, duty cycle 1.5%

2. C_{oss eq.} is defined as a constant equivalent capacitance giving the same charging time as C_{oss} when V_{DS} increases from 0 to 80% V_{DSS}

Table 7. Switching times

| Symbol | Parameter | Test conditions | Min. | Typ. | Max. | Unit |
|--------------|---------------------|--|------|------|------|------|
| $t_{d(on)}$ | Turn-on delay time | $V_{DD} = 300\text{ V}$, $I_D = 5\text{ A}$, | | 22 | | ns |
| t_r | Rise time | $R_G = 4.7\ \Omega$, $V_{GS} = 10\text{ V}$ | | 18.5 | | ns |
| $t_{d(off)}$ | Turn-off delay time | (see Figure 18) | | 50 | | ns |
| t_f | Fall time | (see Figure 23) | | 12 | | ns |

Table 8. Source drain diode

| Symbol | Parameter | Test conditions | Min. | Typ. | Max. | Unit |
|----------------|-------------------------------|---|------|------|------|---------------|
| I_{SD} | Source-drain current | | | | 10 | A |
| I_{SDM} | Source-drain current (pulsed) | | | | 40 | A |
| $V_{SD}^{(1)}$ | Forward on voltage | $I_{SD} = 10\text{ A}$, $V_{GS}=0$ | | | 1.3 | V |
| t_{rr} | Reverse recovery time | $I_{SD} = 10\text{ A}$, $di/dt = 100\text{ A}/\mu\text{s}$, | | 340 | | ns |
| Q_{rr} | Reverse recovery charge | $V_{DD} = 100\text{ V}$ | | 3.26 | | μC |
| I_{RRM} | Reverse recovery current | (see Figure 20) | | 19.2 | | A |
| t_{rr} | Reverse recovery time | $V_{DD} = 100\text{ V}$ | | 460 | | ns |
| Q_{rr} | Reverse recovery charge | $di/dt = 100\text{ A}/\mu\text{s}$, $I_{SD} = 10\text{ A}$ | | 4.42 | | μC |
| I_{RRM} | Reverse recovery current | $T_J = 150\text{ }^\circ\text{C}$ (see Figure 20) | | 19.2 | | A |

1. Pulsed: pulse duration = 300 μs , duty cycle 1.5%

2.1 Electrical characteristics (curves)

Figure 2. Safe operating area for TO-220 / I²PAK / D²PAK

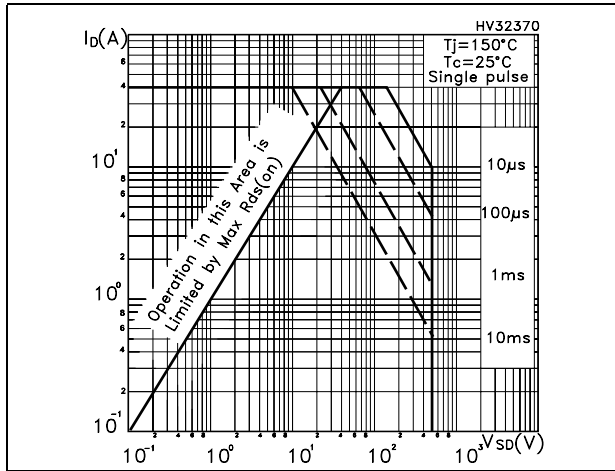

Figure 3. Thermal impedance for TO-220 / I²PAK / D²PAK

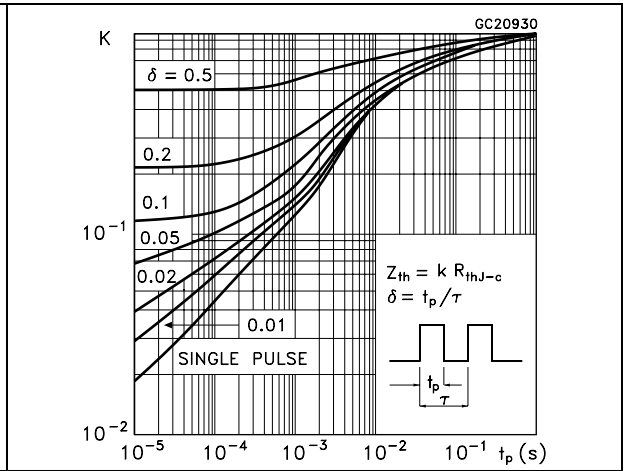

Figure 4. Safe operating area for TO-220FP

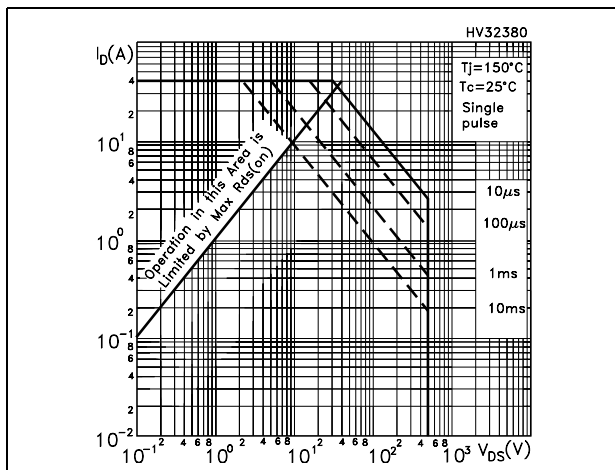

Figure 5. Thermal impedance for TO-220FP

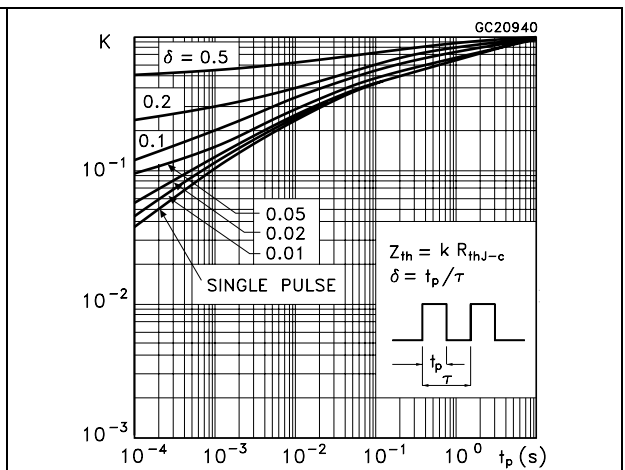

Figure 6. Safe operating area for DPAK / IPAK

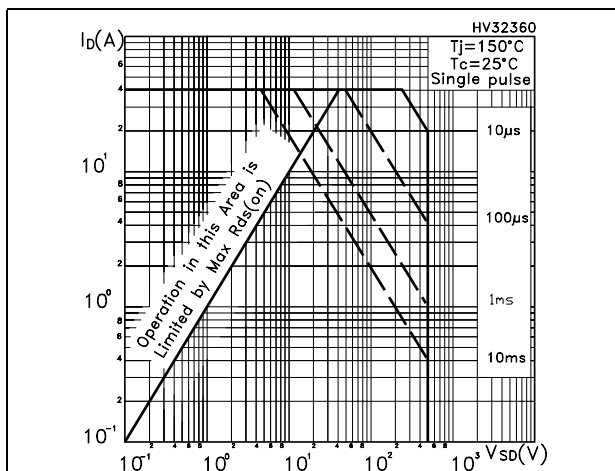

Figure 7. Thermal impedance for DPAK / IPAK

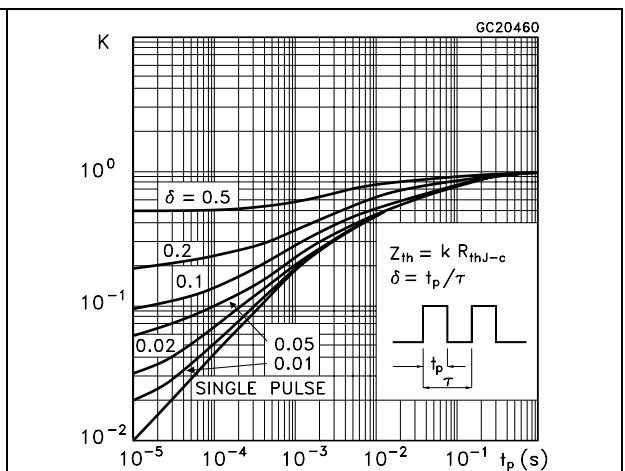

Figure 8. Output characteristics

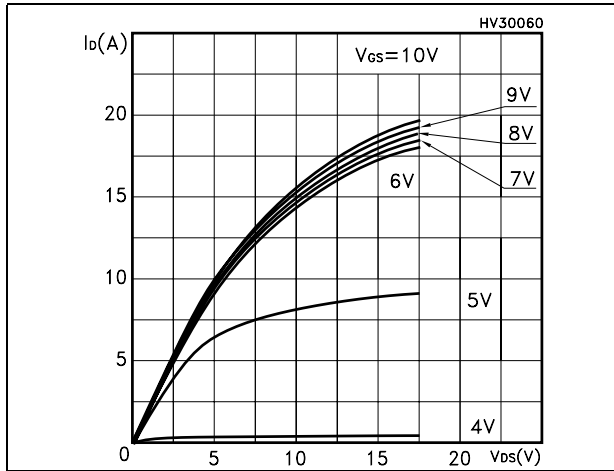

Figure 9. Transfer characteristics

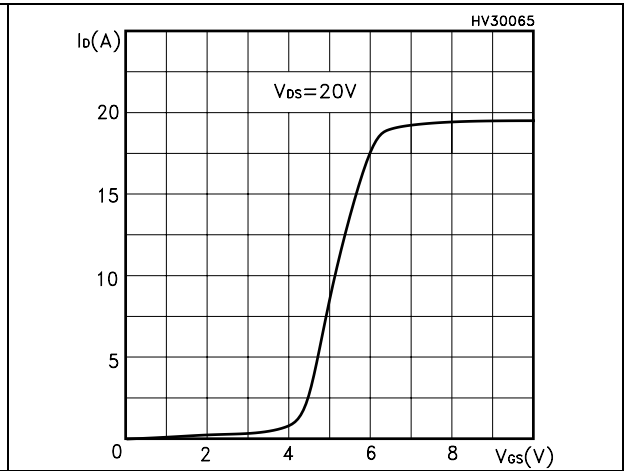

Figure 10. Transconductance

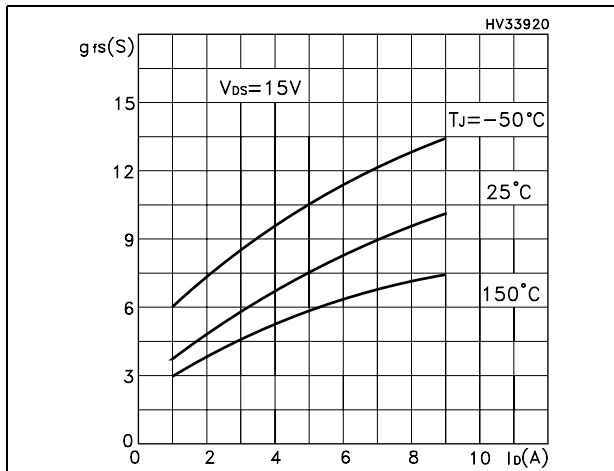

Figure 11. Static drain-source on resistance

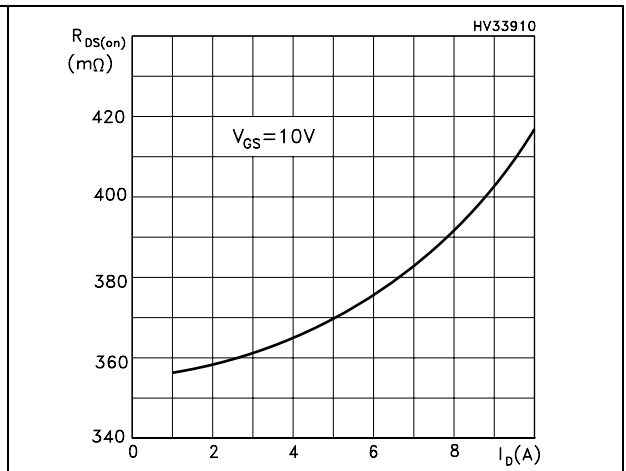

Figure 12. Gate charge vs gate-source voltage

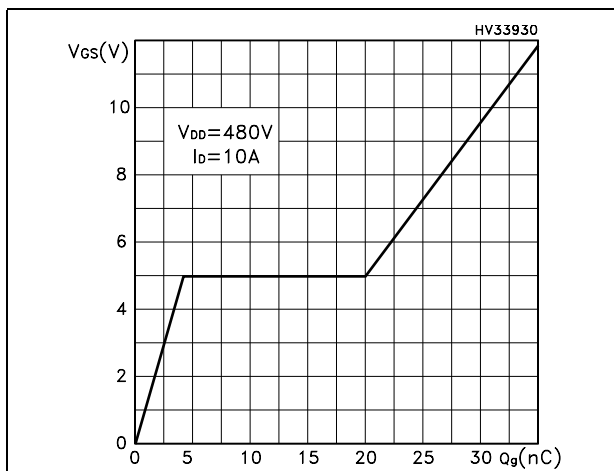

Figure 13. Capacitance variations

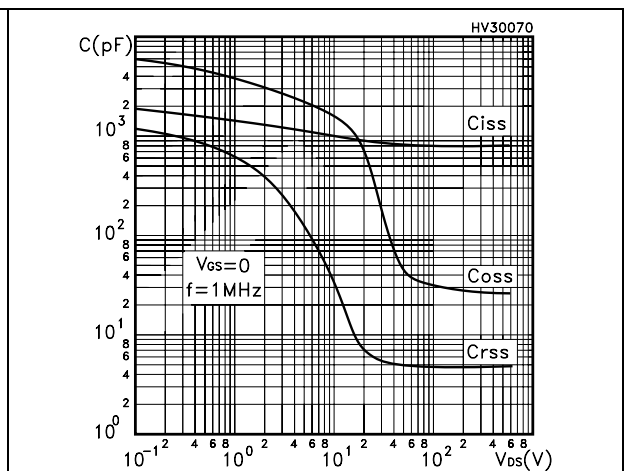

Figure 14. Normalized gate threshold voltage vs temperature

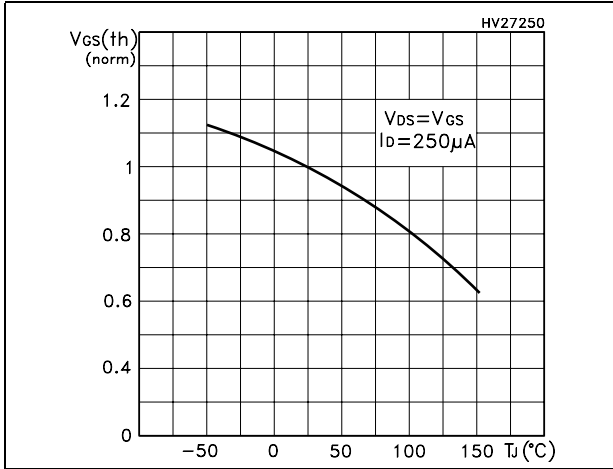

Figure 15. Normalized on resistance vs temperature

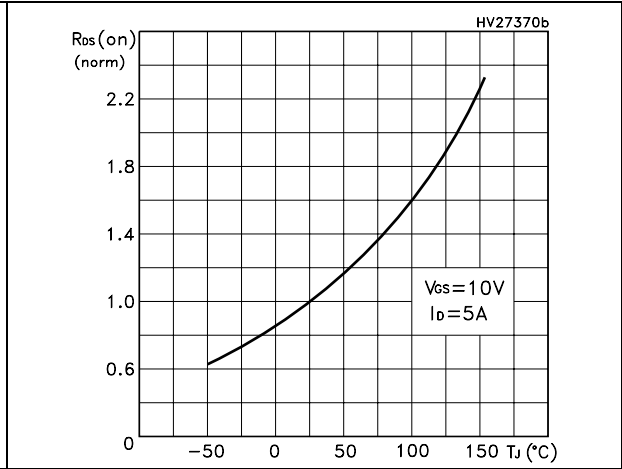

Figure 16. Source-drain diode forward characteristics

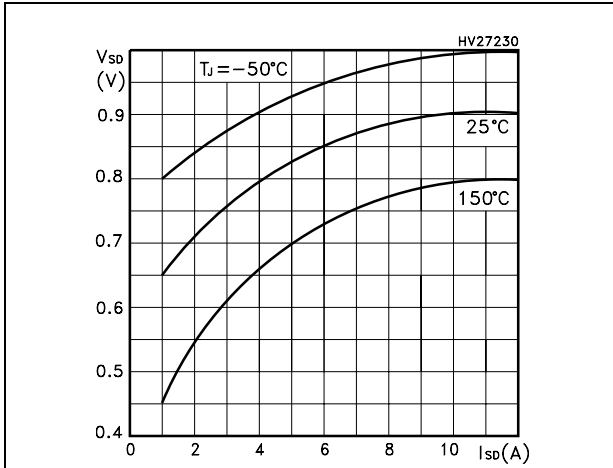
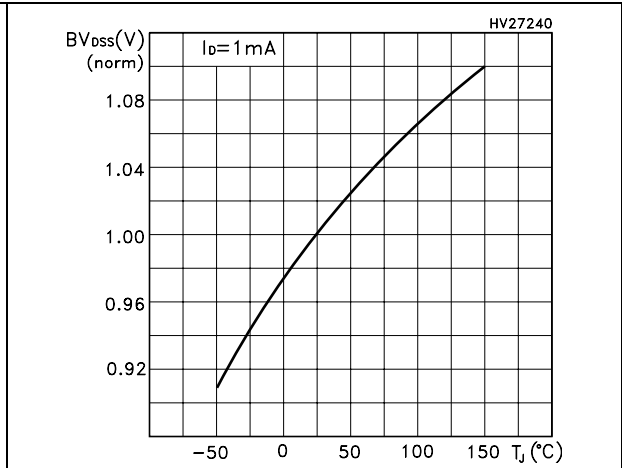

Figure 17. Normalized $B_{V_{DSS}}$ vs temperature



3 Test circuits

Figure 18. Switching times test circuit for resistive load

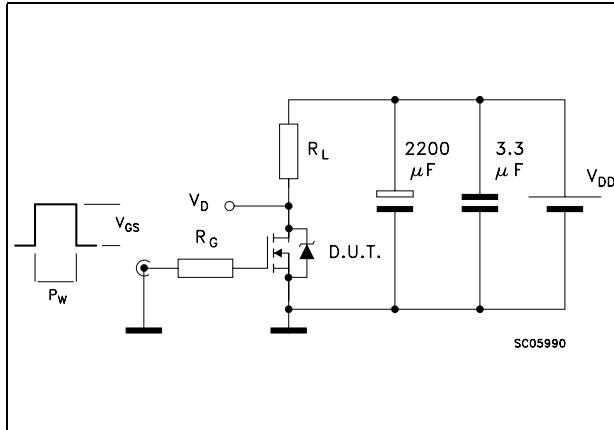

Figure 19. Gate charge test circuit

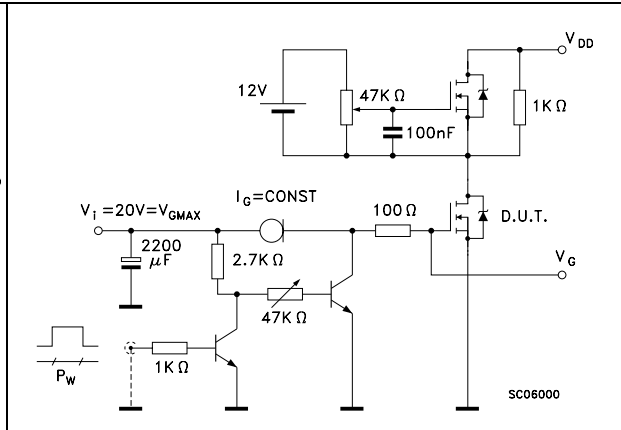

Figure 20. Test circuit for inductive load switching and diode recovery times

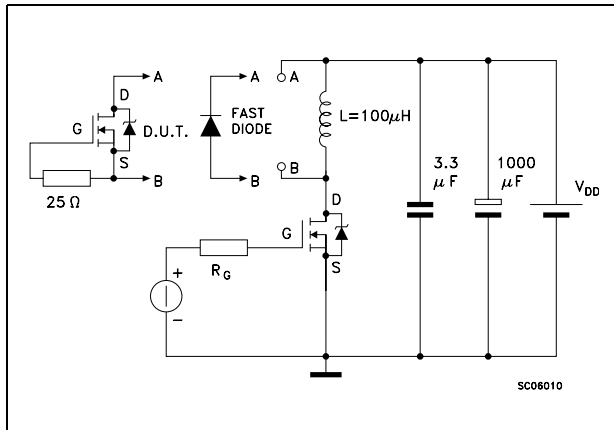

Figure 21. Unclamped inductive load test circuit

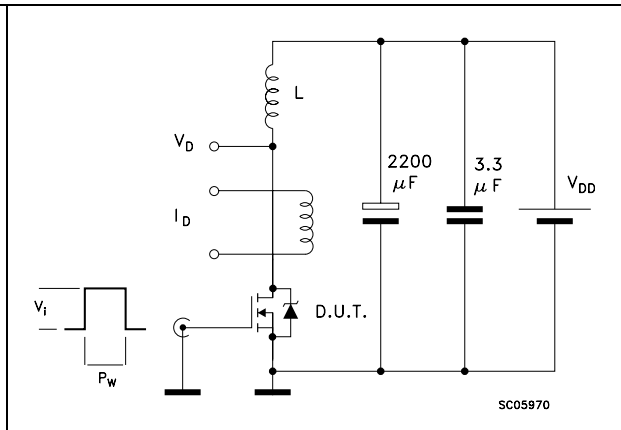

Figure 22. Unclamped inductive waveform

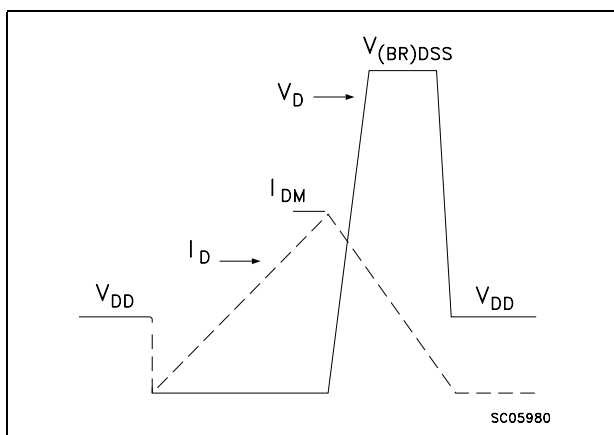
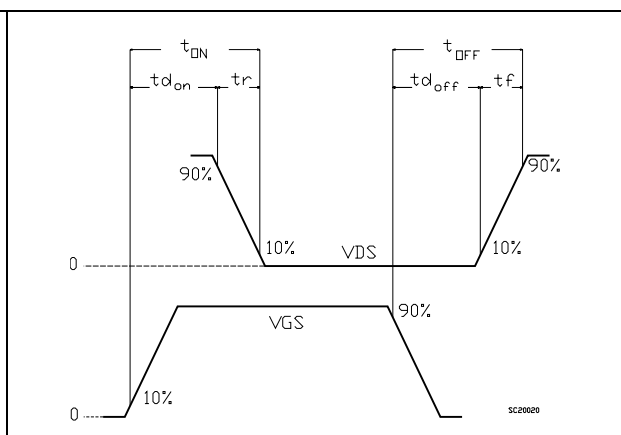

Figure 23. Switching time waveform



4 Package mechanical data

In order to meet environmental requirements, ST offers these devices in ECOPACK® packages. These packages have a Lead-free second level interconnect. The category of second level interconnect is marked on the package and on the inner box label, in compliance with JEDEC Standard JESD97. The maximum ratings related to soldering conditions are also marked on the inner box label. ECOPACK is an ST trademark. ECOPACK specifications are available at: www.st.com

TO-220 mechanical data

| Dim | mm | | | inch | | |
|-----|-------|-------|-------|-------|-------|-------|
| | Min | Typ | Max | Min | Typ | Max |
| A | 4.40 | | 4.60 | 0.173 | | 0.181 |
| b | 0.61 | | 0.88 | 0.024 | | 0.034 |
| b1 | 1.14 | | 1.70 | 0.044 | | 0.066 |
| c | 0.48 | | 0.70 | 0.019 | | 0.027 |
| D | 15.25 | | 15.75 | 0.6 | | 0.62 |
| D1 | | 1.27 | | | 0.050 | |
| E | 10 | | 10.40 | 0.393 | | 0.409 |
| e | 2.40 | | 2.70 | 0.094 | | 0.106 |
| e1 | 4.95 | | 5.15 | 0.194 | | 0.202 |
| F | 1.23 | | 1.32 | 0.048 | | 0.051 |
| H1 | 6.20 | | 6.60 | 0.244 | | 0.256 |
| J1 | 2.40 | | 2.72 | 0.094 | | 0.107 |
| L | 13 | | 14 | 0.511 | | 0.551 |
| L1 | 3.50 | | 3.93 | 0.137 | | 0.154 |
| L20 | | 16.40 | | | 0.645 | |
| L30 | | 28.90 | | | 1.137 | |
| ∅P | 3.75 | | 3.85 | 0.147 | | 0.151 |
| Q | 2.65 | | 2.95 | 0.104 | | 0.116 |

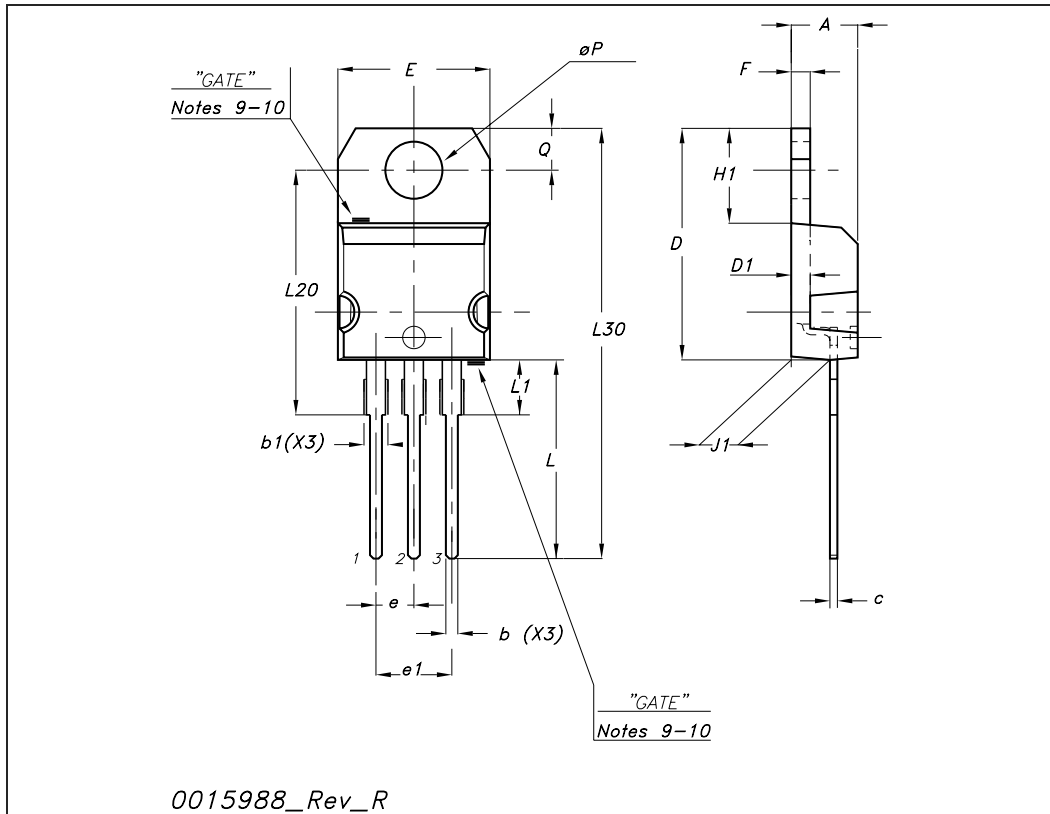

TO-220FP mechanical data

| Dim. | mm. | | | inch | | |
|------|-------|-----|-------|-------|-------|-------|
| | Min. | Typ | Max. | Min. | Typ. | Max. |
| A | 4.40 | | 4.60 | 0.173 | | 0.181 |
| B | 2.5 | | 2.7 | 0.098 | | 0.106 |
| D | 2.5 | | 2.75 | 0.098 | | 0.108 |
| E | 0.45 | | 0.70 | 0.017 | | 0.027 |
| F | 0.75 | | 1.00 | 0.030 | | 0.039 |
| F1 | 1.15 | | 1.50 | 0.045 | | 0.067 |
| F2 | 1.15 | | 1.50 | 0.045 | | 0.067 |
| G | 4.95 | | 5.20 | 0.195 | | 0.204 |
| G1 | 2.40 | | 2.70 | 0.094 | | 0.106 |
| H | 10 | | 10.40 | 0.393 | | 0.409 |
| L2 | | 16 | | | 0.630 | |
| L3 | 28.6 | | 30.6 | 1.126 | | 1.204 |
| L4 | 9.80 | | 10.60 | 0.385 | | 0.417 |
| L5 | 2.9 | | 3.6 | 0.114 | | 0.141 |
| L6 | 15.90 | | 16.40 | 0.626 | | 0.645 |
| L7 | 9 | | 9.30 | 0.354 | | 0.366 |
| Dia | 3 | | 3.2 | 0.118 | | 0.126 |

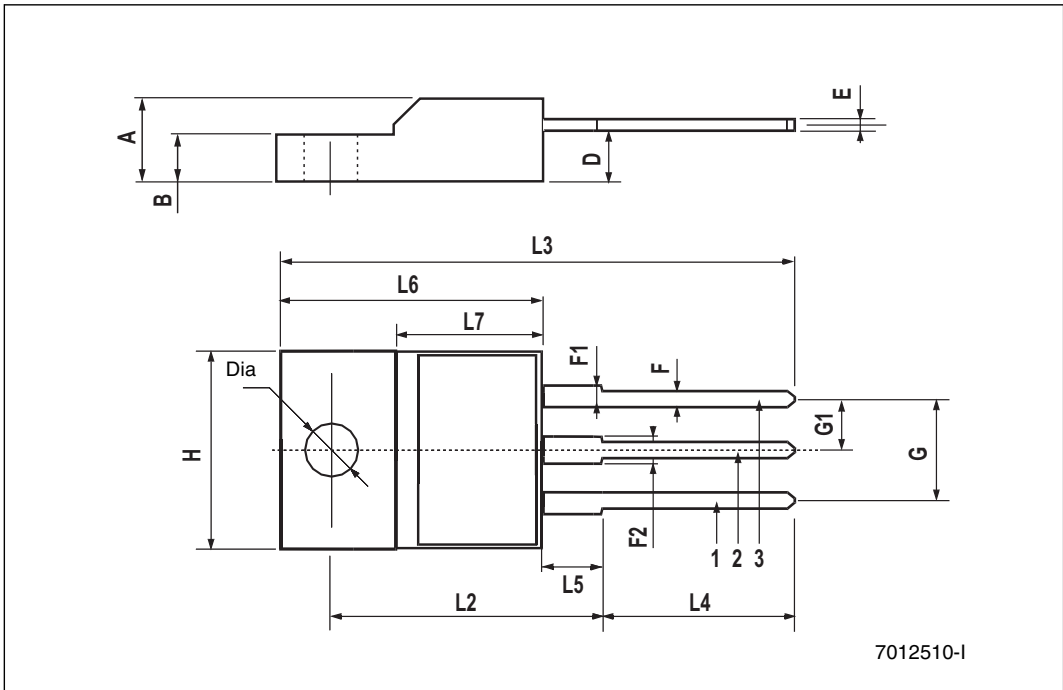

D²PAK (TO-263) mechanical data

| Dim | mm | | | inch | | |
|-----|------|------|-------|-------|-------|-------|
| | Min | Typ | Max | Min | Typ | Max |
| A | 4.40 | | 4.60 | 0.173 | | 0.181 |
| A1 | 0.03 | | 0.23 | 0.001 | | 0.009 |
| b | 0.70 | | 0.93 | 0.027 | | 0.037 |
| b2 | 1.14 | | 1.70 | 0.045 | | 0.067 |
| c | 0.45 | | 0.60 | 0.017 | | 0.024 |
| c2 | 1.23 | | 1.36 | 0.048 | | 0.053 |
| D | 8.95 | | 9.35 | 0.352 | | 0.368 |
| D1 | 7.50 | | | 0.295 | | |
| E | 10 | | 10.40 | 0.394 | | 0.409 |
| E1 | 8.50 | | | 0.334 | | |
| e | | 2.54 | | | 0.1 | |
| e1 | 4.88 | | 5.28 | 0.192 | | 0.208 |
| H | 15 | | 15.85 | 0.590 | | 0.624 |
| J1 | 2.49 | | 2.69 | 0.099 | | 0.106 |
| L | 2.29 | | 2.79 | 0.090 | | 0.110 |
| L1 | 1.27 | | 1.40 | 0.05 | | 0.055 |
| L2 | 1.30 | | 1.75 | 0.051 | | 0.069 |
| R | | 0.4 | | | 0.016 | |
| V2 | 0° | | 8° | 0° | | 8° |

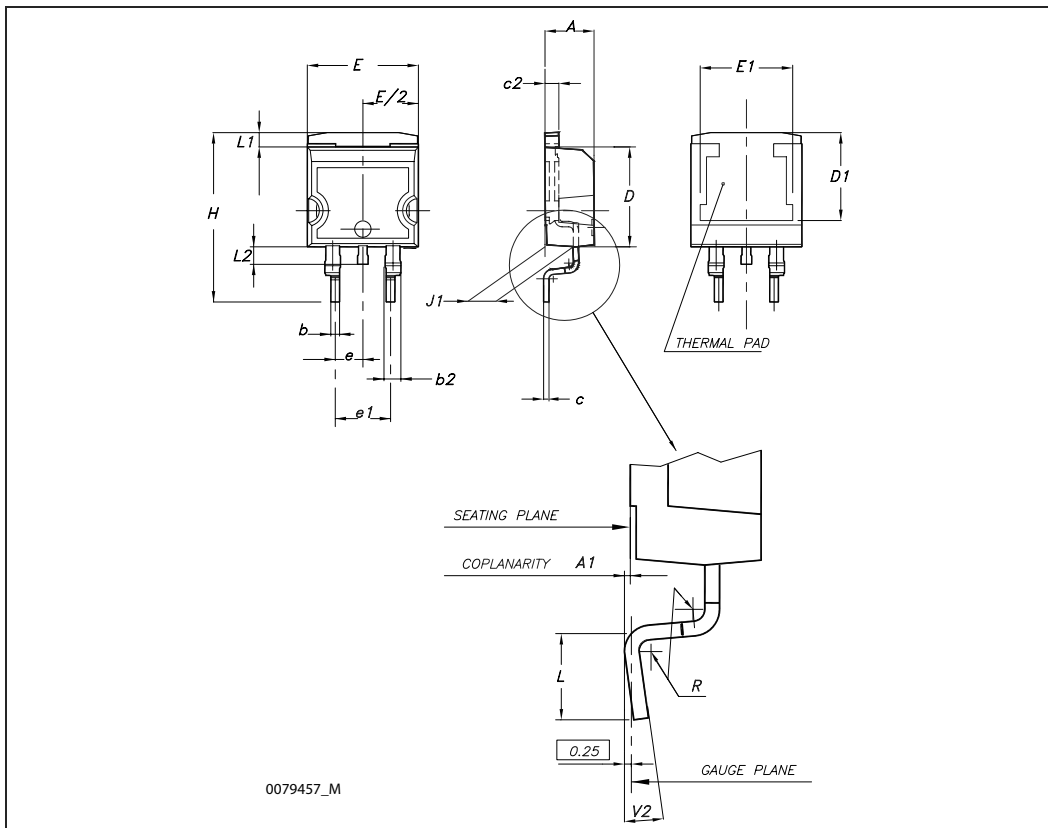

I²PAK (TO-262) mechanical data

| Dim | mm | | | inch | | |
|-----|------|-----|-------|-------|-----|-------|
| | Min | Typ | Max | Min | Typ | Max |
| A | 4.40 | | 4.60 | 0.173 | | 0.181 |
| A1 | 2.40 | | 2.72 | 0.094 | | 0.107 |
| b | 0.61 | | 0.88 | 0.024 | | 0.034 |
| b1 | 1.14 | | 1.70 | 0.044 | | 0.066 |
| c | 0.49 | | 0.70 | 0.019 | | 0.027 |
| c2 | 1.23 | | 1.32 | 0.048 | | 0.052 |
| D | 8.95 | | 9.35 | 0.352 | | 0.368 |
| e | 2.40 | | 2.70 | 0.094 | | 0.106 |
| e1 | 4.95 | | 5.15 | 0.194 | | 0.202 |
| E | 10 | | 10.40 | 0.393 | | 0.410 |
| L | 13 | | 14 | 0.511 | | 0.551 |
| L1 | 3.50 | | 3.93 | 0.137 | | 0.154 |
| L2 | 1.27 | | 1.40 | 0.050 | | 0.055 |

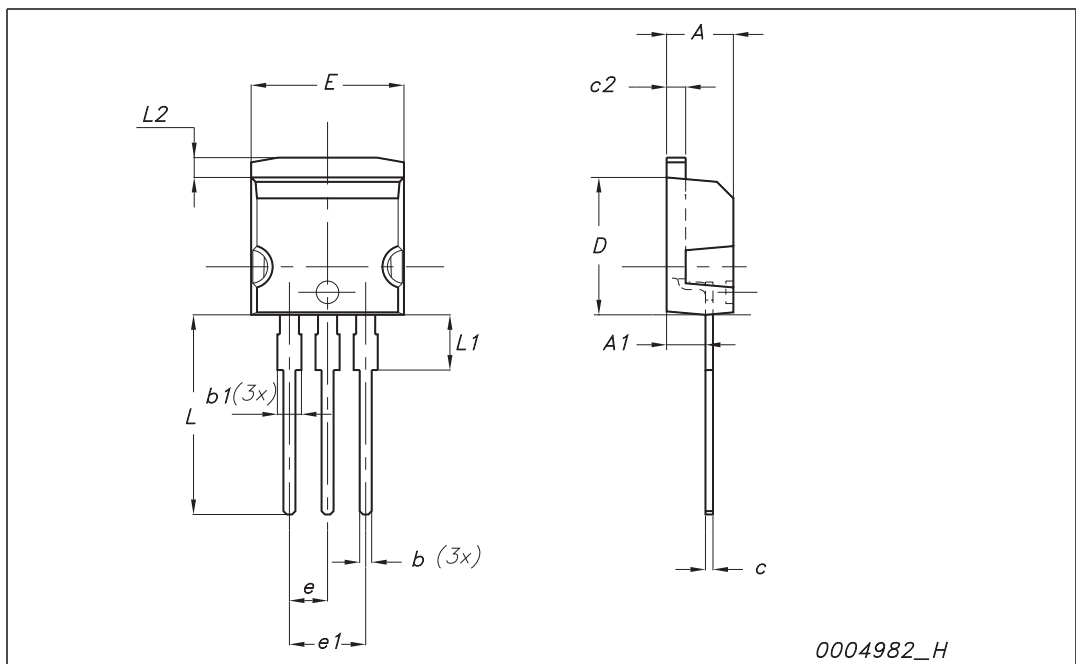

TO-252 (DPAK) mechanical data

| DIM. | mm. | | |
|------|------|------|-------|
| | min. | typ | max. |
| A | 2.20 | | 2.40 |
| A1 | 0.90 | | 1.10 |
| A2 | 0.03 | | 0.23 |
| b | 0.64 | | 0.90 |
| b4 | 5.20 | | 5.40 |
| c | 0.45 | | 0.60 |
| c2 | 0.48 | | 0.60 |
| D | 6.00 | | 6.20 |
| D1 | | 5.10 | |
| E | 6.40 | | 6.60 |
| E1 | | 4.70 | |
| e | | 2.28 | |
| e1 | 4.40 | | 4.60 |
| H | 9.35 | | 10.10 |
| L | 1 | | |
| L1 | | 2.80 | |
| L2 | | 0.80 | |
| L4 | 0.60 | | 1 |
| R | | 0.20 | |
| V2 | 0° | | 8° |

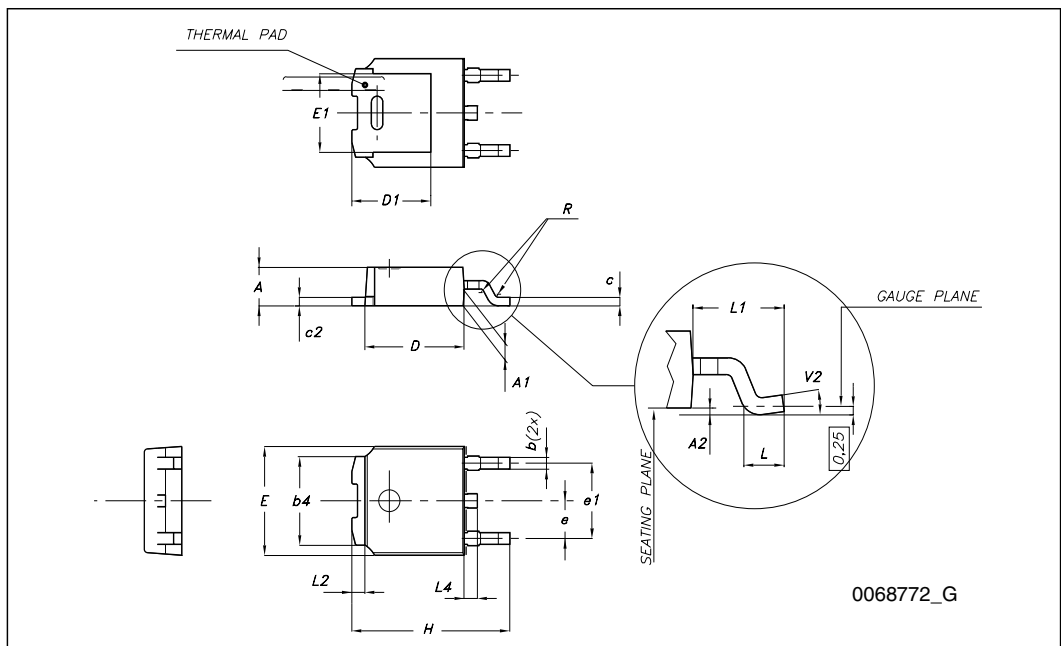

TO-251 (IPAK) mechanical data

| DIM. | mm. | | |
|------|------|-------|------|
| | min. | typ | max. |
| A | 2.20 | | 2.40 |
| A1 | 0.90 | | 1.10 |
| b | 0.64 | | 0.90 |
| b2 | | | 0.95 |
| b4 | 5.20 | | 5.40 |
| c | 0.45 | | 0.60 |
| c2 | 0.48 | | 0.60 |
| D | 6.00 | | 6.20 |
| E | 6.40 | | 6.60 |
| e | | 2.28 | |
| e1 | 4.40 | | 4.60 |
| H | | 16.10 | |
| L | 9.00 | | 9.40 |
| (L1) | 0.80 | | 1.20 |
| L2 | | 0.80 | |
| V1 | | 10° | |

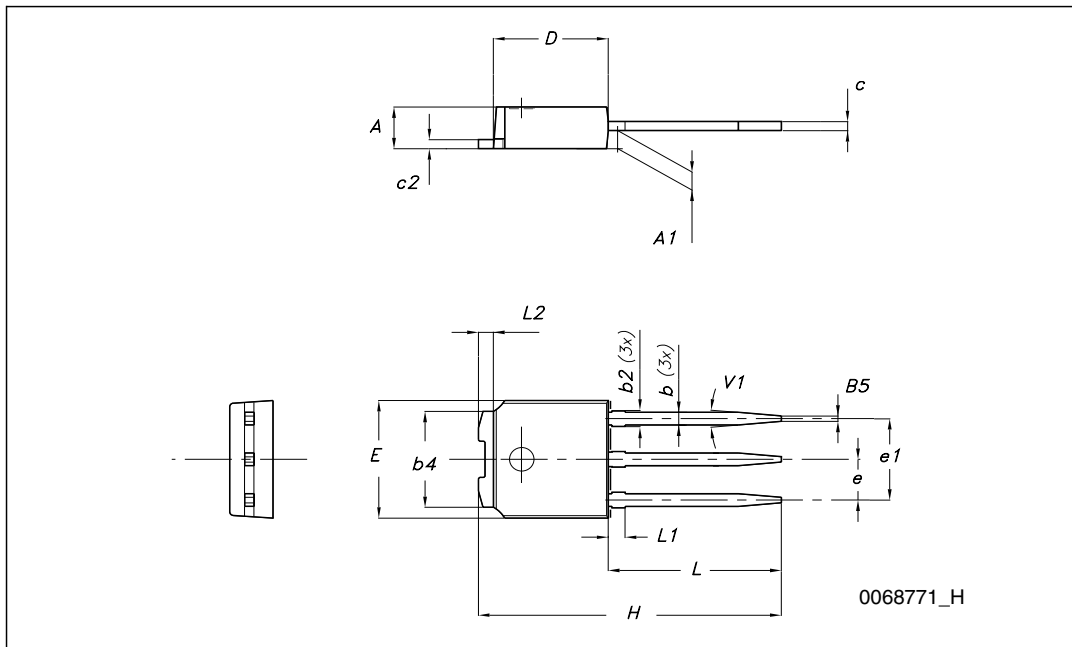

5 Packaging mechanical data

DPAK FOOTPRINT

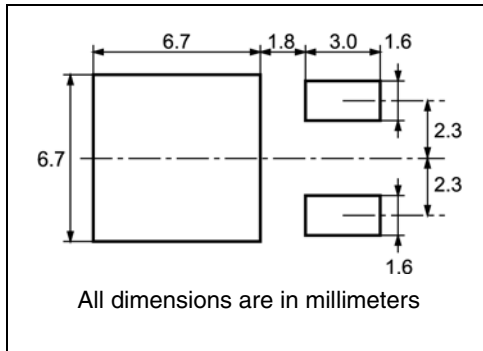

TAPE AND REEL SHIPMENT

| DIM. | mm | | inch | |
|------|------|------|-------|--------|
| | MIN. | MAX. | MIN. | MAX. |
| A | | 330 | | 12.992 |
| B | 1.5 | | 0.059 | |
| C | 12.8 | 13.2 | 0.504 | 0.520 |
| D | 20.2 | | 0.795 | |
| G | 16.4 | 18.4 | 0.645 | 0.724 |
| N | 50 | | 1.968 | |
| T | | 22.4 | | 0.881 |

| BASE QTY | BULK QTY |
|----------|----------|
| 2500 | 2500 |

| DIM. | mm | | inch | |
|------|------|------|-------|-------|
| | MIN. | MAX. | MIN. | MAX. |
| A0 | 6.8 | 7 | 0.267 | 0.275 |
| B0 | 10.4 | 10.6 | 0.409 | 0.417 |
| B1 | | 12.1 | | 0.476 |
| D | 1.5 | 1.6 | 0.059 | 0.063 |
| D1 | 1.5 | | 0.059 | |
| E | 1.65 | 1.85 | 0.065 | 0.073 |
| F | 7.4 | 7.6 | 0.291 | 0.299 |
| K0 | 2.55 | 2.75 | 0.100 | 0.108 |
| P0 | 3.9 | 4.1 | 0.153 | 0.161 |
| P1 | 7.9 | 8.1 | 0.311 | 0.319 |
| P2 | 1.9 | 2.1 | 0.075 | 0.082 |
| R | 40 | | 1.574 | |
| W | 15.7 | 16.3 | 0.618 | 0.641 |

D²PAK FOOTPRINT

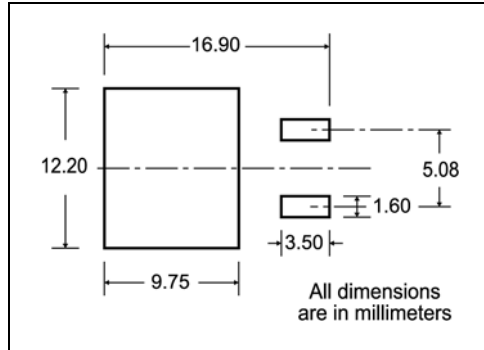

TAPE AND REEL SHIPMENT

TAPE MECHANICAL DATA

| DIM. | mm | | inch | |
|------|------|------|--------|--------|
| | MIN. | MAX. | MIN. | MAX. |
| A0 | 10.5 | 10.7 | 0.413 | 0.421 |
| B0 | 15.7 | 15.9 | 0.618 | 0.626 |
| D | 1.5 | 1.6 | 0.059 | 0.063 |
| D1 | 1.59 | 1.61 | 0.062 | 0.063 |
| E | 1.65 | 1.85 | 0.065 | 0.073 |
| F | 11.4 | 11.6 | 0.449 | 0.456 |
| K0 | 4.8 | 5.0 | 0.189 | 0.197 |
| P0 | 3.9 | 4.1 | 0.153 | 0.161 |
| P1 | 11.9 | 12.1 | 0.468 | 0.476 |
| P2 | 1.9 | 2.1 | 0.075 | 0.082 |
| R | 50 | | 1.574 | |
| T | 0.25 | 0.35 | 0.0098 | 0.0137 |
| W | 23.7 | 24.3 | 0.933 | 0.956 |

REEL MECHANICAL DATA

| DIM. | mm | | inch | |
|------|------|------|-------|--------|
| | MIN. | MAX. | MIN. | MAX. |
| A | | 330 | | 12.992 |
| B | 1.5 | | 0.059 | |
| C | 12.8 | 13.2 | 0.504 | 0.520 |
| D | 20.2 | | 0.795 | |
| G | 24.4 | 26.4 | 0.960 | 1.039 |
| N | 100 | | 3.937 | |
| T | | 30.4 | | 1.197 |

| BASE QTY | BULK QTY |
|----------|----------|
| 1000 | 1000 |

10 pitches cumulative tolerance on tape +/- 0.2 mm

Center line of cavity

User Direction of Feed

FEED DIRECTION

Bending radius

* on sales type

6 Revision history

Table 9. Document revision history

| Date | Revision | Changes |
|-------------|----------|--|
| 03-Aug-2006 | 1 | First release |
| 14-Nov-2006 | 2 | Complete version |
| 02-Oct-2007 | 3 | Figure 8.: Output characteristics has been updated. Added new package (I ² PAK) |
| 03-Mar-2008 | 4 | Added new package D ² PAK |

Please Read Carefully:

Information in this document is provided solely in connection with ST products. STMicroelectronics NV and its subsidiaries ("ST") reserve the right to make changes, corrections, modifications or improvements, to this document, and the products and services described herein at any time, without notice.

All ST products are sold pursuant to ST's terms and conditions of sale.

Purchasers are solely responsible for the choice, selection and use of the ST products and services described herein, and ST assumes no liability whatsoever relating to the choice, selection or use of the ST products and services described herein.

No license, express or implied, by estoppel or otherwise, to any intellectual property rights is granted under this document. If any part of this document refers to any third party products or services it shall not be deemed a license grant by ST for the use of such third party products or services, or any intellectual property contained therein or considered as a warranty covering the use in any manner whatsoever of such third party products or services or any intellectual property contained therein.

UNLESS OTHERWISE SET FORTH IN ST'S TERMS AND CONDITIONS OF SALE ST DISCLAIMS ANY EXPRESS OR IMPLIED WARRANTY WITH RESPECT TO THE USE AND/OR SALE OF ST PRODUCTS INCLUDING WITHOUT LIMITATION IMPLIED WARRANTIES OF MERCHANTABILITY, FITNESS FOR A PARTICULAR PURPOSE (AND THEIR EQUIVALENTS UNDER THE LAWS OF ANY JURISDICTION), OR INFRINGEMENT OF ANY PATENT, COPYRIGHT OR OTHER INTELLECTUAL PROPERTY RIGHT.

UNLESS EXPRESSLY APPROVED IN WRITING BY AN AUTHORIZED ST REPRESENTATIVE, ST PRODUCTS ARE NOT RECOMMENDED, AUTHORIZED OR WARRANTED FOR USE IN MILITARY, AIR CRAFT, SPACE, LIFE SAVING, OR LIFE SUSTAINING APPLICATIONS, NOR IN PRODUCTS OR SYSTEMS WHERE FAILURE OR MALFUNCTION MAY RESULT IN PERSONAL INJURY, DEATH, OR SEVERE PROPERTY OR ENVIRONMENTAL DAMAGE. ST PRODUCTS WHICH ARE NOT SPECIFIED AS "AUTOMOTIVE GRADE" MAY ONLY BE USED IN AUTOMOTIVE APPLICATIONS AT USER'S OWN RISK.

Resale of ST products with provisions different from the statements and/or technical features set forth in this document shall immediately void any warranty granted by ST for the ST product or service described herein and shall not create or extend in any manner whatsoever, any liability of ST.

ST and the ST logo are trademarks or registered trademarks of ST in various countries.

Information in this document supersedes and replaces all information previously supplied.

The ST logo is a registered trademark of STMicroelectronics. All other names are the property of their respective owners.

© 2008 STMicroelectronics - All rights reserved

STMicroelectronics group of companies

Australia - Belgium - Brazil - Canada - China - Czech Republic - Finland - France - Germany - Hong Kong - India - Israel - Italy - Japan - Malaysia - Malta - Morocco - Singapore - Spain - Sweden - Switzerland - United Kingdom - United States of America

www.st.com