

Model WS7.5 with analog or SSI output

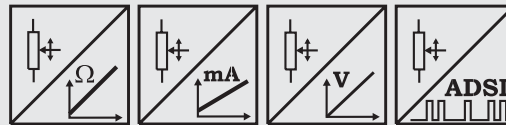

Compact industrial sensor for long ranges

- Protection class IP52
- Measurement ranges:
0 ... 10000 mm to 0 ... 40000 mm
- Analog output 0 ... 10 V, 4 ... 20 mA, potentiometer or A/D converted synchronous serial output (SSI)



Specifications	Outputs	Potentiometer: 1 kΩ Voltage: 0 ... 10 V Current: 4 ... 20 mA Voltage and current output, adjustable A/D converted synchronous serial max. 16 bit
	Resolution	Analog: essentially infinite; ADSI16: max. 16 bit f.s.
	Material	Aluminium and stainless steel. Cable: stainless steel
	Sensing device	Precision potentiometer
	Connector	8 pin socket (M12 or DIN 45326)
	Continuation at page 28	

Order code WS7.5 Analog or SSI

Model Name	WS7.5 - [] - [] - [] - [] - []
Measurement Range (in mm)	10000 / 20000 / 30000 / 40000
Outputs (see pages 57 ff.)	R1K = Potentiometer 1 kΩ (other values on request) 10V = with 0 ... 10 V signal conditioner 420A = with 4 ... 20 mA signal conditioner (2 wire) 420T = with 4 ... 20 mA signal conditioner (3 wire) PMU = with 0...10 V/4...20 mA signal conditioner, adjustable ADSI16 = with A/D converted synchronous serial output 16 bit (option: 12, 14 bit)
Linearity	L10 = ±0.10 % option: L05 = ±0,05 % L25 = ±0.25 %
Cable fixing	M4 = M4 cable fixing SB0 = Cable clip
Connection	M12 = 8 pin socket M12 D8 = 8 pin socket DIN 45326

Order Code Mating Connector (see accessories p. 82) D8: **CONN-DIN-8F-W** M12: **CONN-M12-8F-G**

Order Example: WS7.5 - 30000 - 420T - M4 - M12

Model WS7.5 with absolute or incremental encoder output



Compact industrial sensor for long ranges

- Protection class IP52
- Measurement ranges:
0 ... 10000 mm to 0 ... 40000 mm
- Absolute or incremental encoder

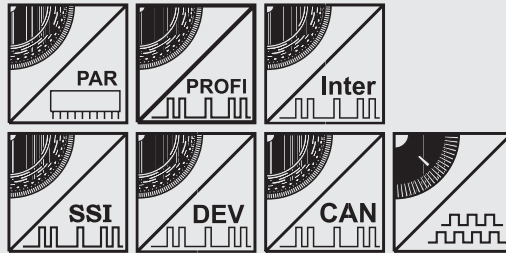

Specifications (Continuation)	Outputs	See order code
	Resolution for 12 bit per revolution (4096 steps/rev.)	Up to 30000 mm range: 0.073 mm 40000 mm range: 0.088 mm
	Material	Aluminium and stainless steel. Cable: stainless steel
	Sensing device	Precision potentiometer
	Connector	Depending on the encoder type

Continuation at page 28

Order Code WS7.5

Absolute or incremental

Model Name

WS7.5

Measurement Range (in mm)

10000 / 20000 / 25000 / 30000 / 40000

Outputs (see pages 61 ff.)

- ME = Mechanism only for installation of suitable multiturn encoders
- BK = Customer sources encoder for fitting by ASM
- LD5VC = Incremental encoder TTL compatible inverted
- PP24VC = Incremental encoder HTL compatible inverted
- HSSI = Absolute encoder with synchronous serial output (SSI)
- HSSIP = Absolute encoder with synchronous serial output (SSI), programmable
- HPROF = Absolute encoder with Profibus interface
- HINT = Absolute encoder with Interbus interface
- HCAN = Absolute encoder with CAN bus interface
- HCANOP = Absolute encoder with CANopen bus interface
- HDEV = Absolute encoder with DeviceNet interface
- HPAR = Absolute encoder with parallel interface

Linearity (Option)

L01 = ±0,01 %

Cable fixing

- M4 = M4 cable fixing
- SB0 = Cable clip

Order Code Mating Connector (see accessories page 82)

Incremental, SSI: **CONN-CONIN-12F-G**

Order Example: WS7.5 - 30000 - HSSI - M4

Model WS7.5

with analog output,
or with absolute or incremental encoder output



Specifications (Continuation)	Linearity	Analog up to ± 0.05 % f.s. Encoder up to ± 0.01 % f.s.
	Protection class	IP52
	Weight	10 kg max.
	Environmental	
	EMC	Refer to output specification
Temperature	Refer to output specification	

Cable Forces typical at 20 °C	Range [mm]	Maximum pull-out force [N]	Minimum pull-in force [N]
	10000 - 30000	8.0	4.2
	40000	7.0	3.4

Outline drawing

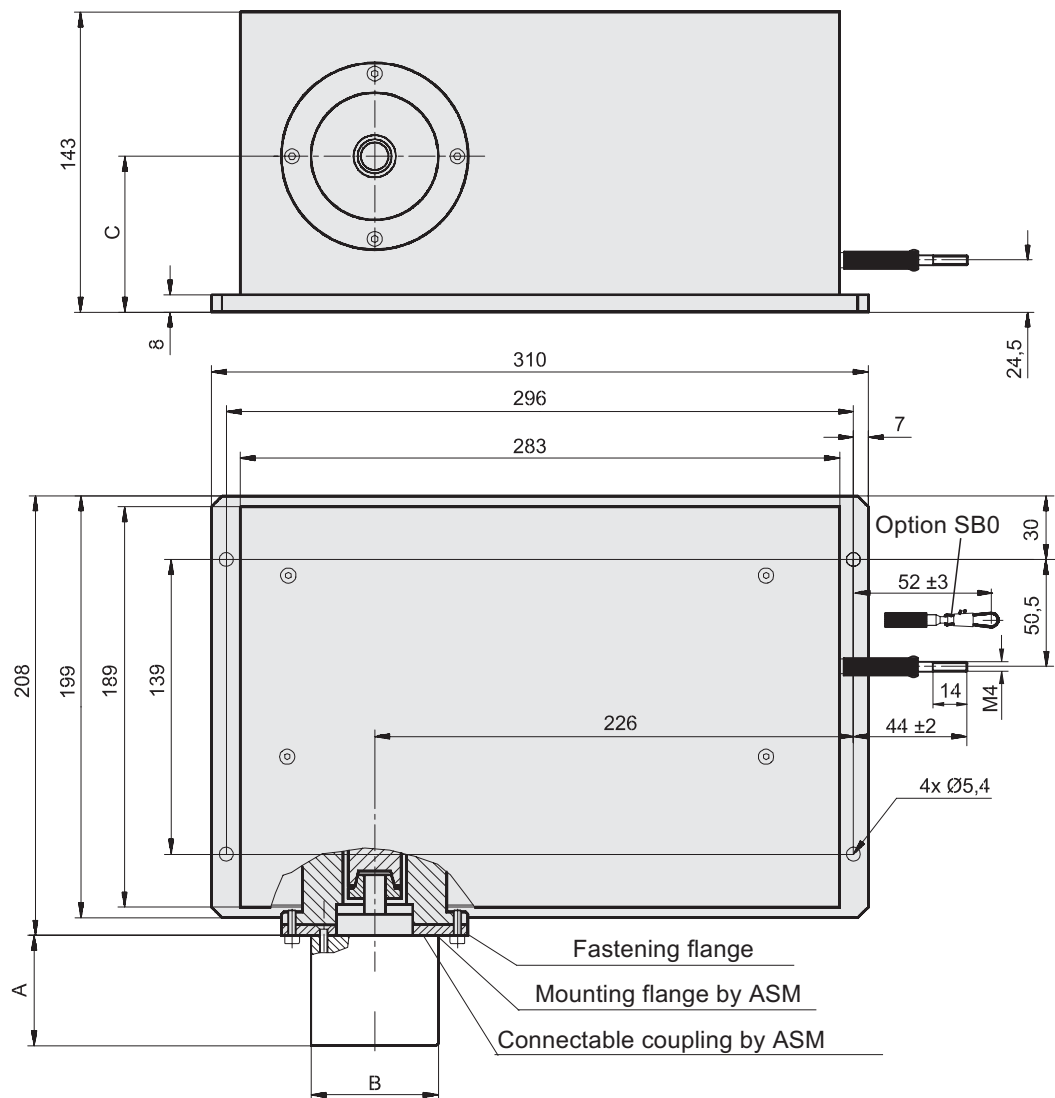

Dimensions informative only.
For guaranteed dimensions
consult factory

Dimensions	Output	Design	A	B	C
	Analog	Closed housing with connector	–	–	34 (Connector position)
	Encoder ME	Mounting flange	Depending on encoder type		79.5

Model WS7.5
with analog output,
or with absolute or incremental encoder output



Output ME

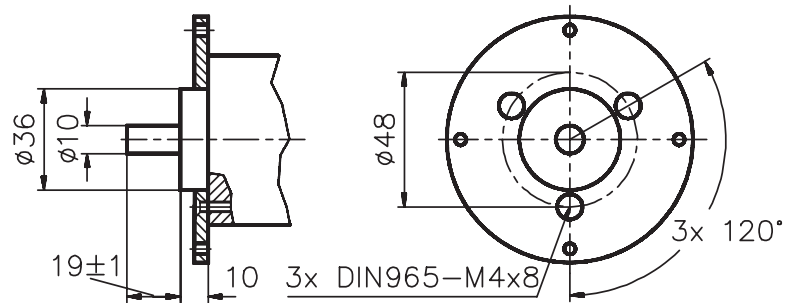

Dimensions for encoder mounting

**Connectable Coupling in two parts
(output ME)**

The outer part of the coupling should be fitted to the encoder shaft. Adjust a 0.5 mm clearance between the fastening and the mounting flanges to give an initial tension on the coupling when the mounting bolts are tightened.

Dimensions informative only.
For guaranteed dimensions consult factory

Output Specifications

R1K and 10V for WS position sensors



Voltage divider R1K Potentiometer 	Excitation Voltage	32 VDC max. at 1 kΩ (input power 1 W max.)
	Potentiometer Impedance	1 kΩ ±10%
	Thermal coefficient	±25 x 10 ⁻⁶ / °C full scale
	Sensitivity	Depends on measurement range, individual sensitivity of sensor specified on label
	Voltage Divider Utilization Range	Approx. 3% ... 97% of full range
	Operating Temperature	-20 ... +85 °C

Signal diagram

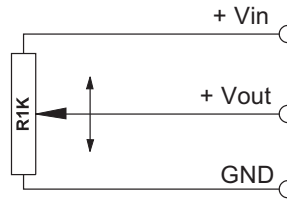

Note: The potentiometer must be connected as a voltage divider. The input impedance of the following processing circuit should be 10 MΩ min.

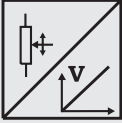
Signal conditioner 10V Voltage output 	Excitation Voltage	+18 ... +27 V DC non stabilized
	Excitation Current	20 mA max.
	Output Voltage	0 ... +10 V DC
	Output Current	2 mA max.
	Output Load	> 5 kΩ
	Stability (Temperature)	±50 x 10 ⁻⁶ / °C full scale
	Protection	Reverse polarity, short circuit
	Output Noise	0,5 mV _{RMS}
	Operating Temperature	-20 ... +85 °C
	EMC	According to EN 61326:2004

Signal diagram

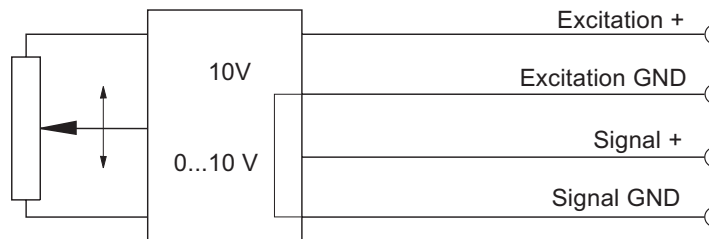

Signal Wiring	Output signals		Cable color	Connector pin no.
	R1K	10V		
	+ Vin	Excitation +	White	1
	GND	Excitation GND	Brown	2
	+ Vout	Signal +	Green	3
		Signal GND	Yellow	4

Connection

Mating Connector

View to solder terminals

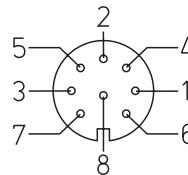

CONN-DIN-8F-W

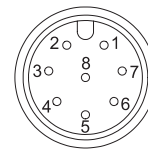

CONN-M12-8F-G

Output Specifications

420A and 420T for WS position sensors

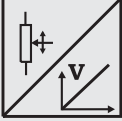

Signal conditioner 420A Current output (2 wire) 	Excitation Voltage	+12 ... 27 VDC non stabilized, measured at the sensor terminals
	Excitation Current	35 mA max.
	Output Current	4 ... 20 mA equivalent to 0 ... 100% range
	Stability (Temperature)	$\pm 100 \times 10^{-6} / ^\circ\text{C}$ full scale
	Protection	Reverse polarity, short circuit
	Output Noise	0.5 mV _{RMS}
	Operating Temperature	-20 ... +85 °C
	EMC	According to EN 61326:2004

Signal Diagram

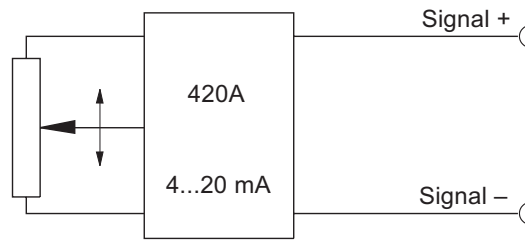

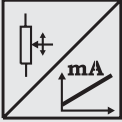
Signal Conditioner 420T Current output (3 wire) 	Excitation Voltage	+18...+27 V DC non stabilized
	Excitation Current	40 mA max.
	Load Resistor	350 Ω max.
	Output Current	4 ... 20 mA equivalent to 0 ... 100% range
	Stability (Temperature)	$\pm 50 \times 10^{-6} / ^\circ\text{C}$ full scale
	Protection	Reverse polarity, short circuit
	Output Noise	0.5 mV _{RMS}
	Operating Temperature	-20 ... +85 °C
	EMC	According to EN 61326:2004

Signal diagram

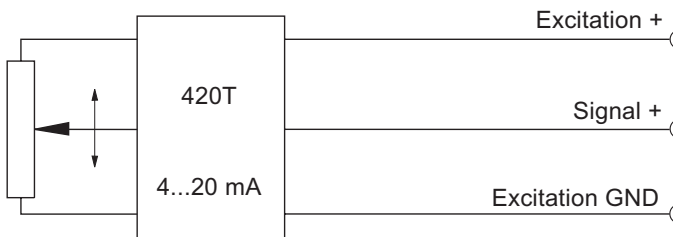

Signal Wiring	Output signals		Cable color	Connector pin no.
	420A	420T		
Signal +		Excitation +	White	1
Signal -		Excitation GND	Brown	2
		Signal +	Green	3

Connection

Mating Connector

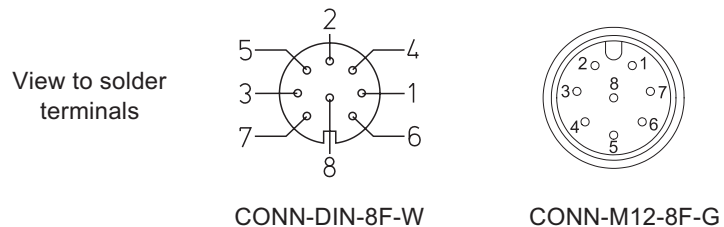

Output Specification

PMU for WS position sensors



Signal Conditioner PMU, adjustable Voltage output and current output (3 wire)	Excitation voltage	+18 ... 27 V DC
	Excitation current	50 mA max.
	Voltage output	0 ... 10 V
	Output current	10 mA max.
	Output load	1 kΩ min.
	Current output	4 ... 20 mA (3 wire)
	Load resistor	500 Ω max.
	Adjustment	
	Activation of offset and gain adjust	Connect with excitation GND (0 V)
	Scalable range	90 % max. full scale
	Stability (Temperature)	$\pm 50 \times 10^{-6} / ^\circ\text{C}$ full scale
	Protection	Reverse polarity, short circuit
	Output noise	1 mV _{eff}
Operating temperature	-20 ... +85 °C	
EMC	According to EN 61326:2004	

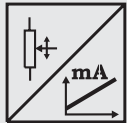
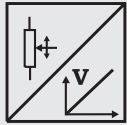

Signal diagram

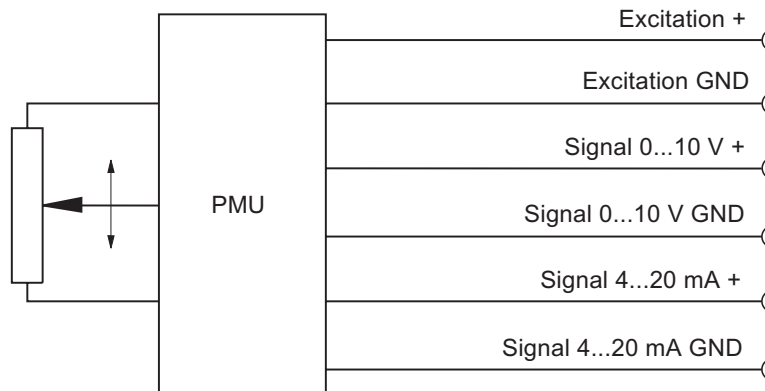

Signal wiring	Output signals	Connector pin no.
	Excitation +	1
	Excitation GND	2
	Signal 0...10 V +	3
	Signal 0...10 V GND	4
	Signal 4...20 mA +	5
	Signal 4...20 mA GND	6
	Offset	7
	Gain	8

Connection

Mating Connector

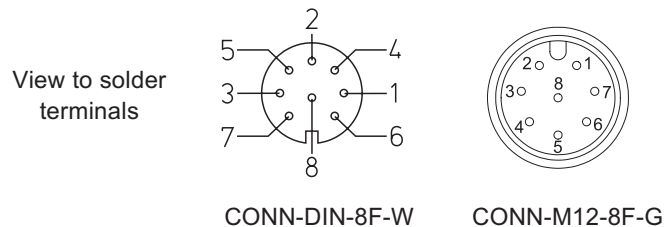

Output Specification

ADSI16 for WS position sensors



- Resolution 16 bit, data transmission synchronous serial/SSI
- Optional available with 12 bit (ADSI) or 14 bit (ADSI14) resolution
- No loss of data at power-down
- Easy to connect to PLC's with SSI input circuit

Description

The sensing device of the ADSI is a precision potentiometer. The position information is given by an analog/digital converter output serialized as a data word. Data transmission takes place by means of the signals CLOCK and DATA. The processing unit (PLC, Micro-computer) sends pulse sequences which clock the data transmission with the required transfer rate. With the first falling edge of a pulse sequence the position of the sensor is recorded and stored. The following rising edges control the bit-by-bit A/D conversion, encoding and output of the data word. After a delay time the next new position information will be transmitted.

Data Format

(Train of 26 Pulses)



Signal Conditioner

ADSI

A/D converted synchronous serial



Output	EIA RS-422, RS-485, short-circuit proof
Excitation voltage	11 ... 27 VDC
Excitation current	200 mA max.
Clock frequency	70 ... 500 kHz
Code	Gray code, continuous progression
Delay between pulse trains	T=30 μs min.
Resolution	16 bit (65536 counts) full scale; optional 12 bit or 14 bit
Stability (temperature)	±50 x 10 ⁻⁶ / °C full scale
Operation temperature	-20 ... +85 °C
EMC	According to EN 61326:2004

Recommended Processing Input Circuit

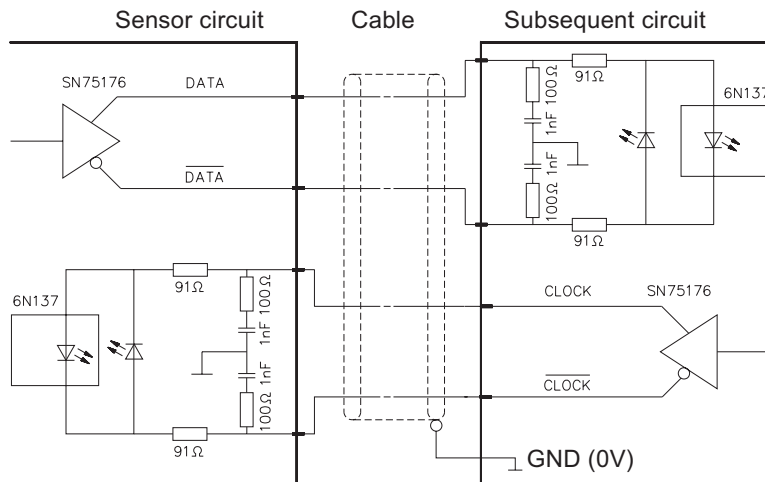

Transmission rate

Cable length	Baud rate
< 50 m	< 300 kHz
< 100 m	< 100 kHz

Note:

Extension of the cable length will reduce the maximum transmission rate. The signals CLOCK/CLOCK and DATA/DATA must be connected in a twisted pair cable, shielded per pair and common.

Signal Wiring

Signal names	Connector pin no.
Excitation +	1
Excitation GND (0V)	2
CLOCK	3
CLOCK	4
DATA	5
DATA	6
Screen	not connected

Mating connector: view to solder terminals

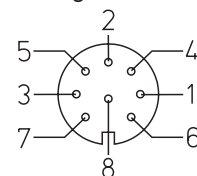

CONN-DIN-8F-W

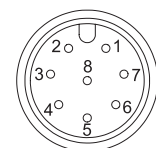

CONN-M12-8F-G

Output Specifications

IE58LI and IE58HI (IE41LI and IE41HI)

for WS position sensors

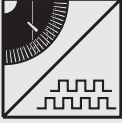

IE58LI and IE58HI incremental	IE58LI / IE41LI		IE58HI / IE41HI
		Excitation voltage	5 V DC $\pm 10\%$
	Excitation current	120 mA max.	
	Max. frequency	300 kHz	200 kHz
	Output	RS422	Push-pull antivalent
	Output current	± 30 mA	30 mA
	Output voltage	Depending on the excitation voltage	
	Stability (temperature)	$\pm 20 \times 10^{-6} / ^\circ\text{C}$ f.s. (sensor mechanism)	
	Operation temperature	-10 ... +70 $^\circ\text{C}$	
	Protection against short circuit	1 channel for 1 s max.	Yes
	EMC	According to EN 61326:2004	

Output circuit and recommended processing input circuit

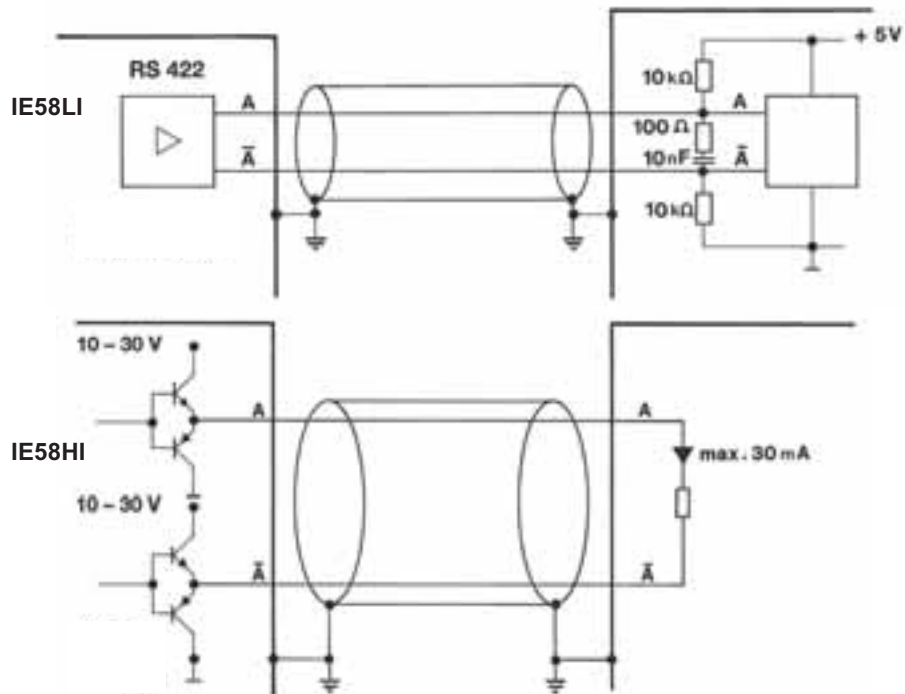

Output signals

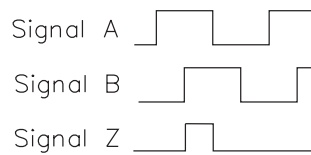

Signal wiring	Output signals	Connector CONN-CONIN-12F
		Excitation +
	Excitation GND (0V)	10
	Signal A	5
	Signal \bar{A}	6
	Signal B	8
	Signal \bar{B}	1
	Signal Z (reference pulse)	3
	Signal \bar{Z}	4

Connection

Mating connector

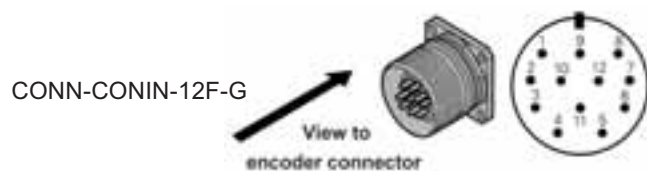

Output Specifications

PP24V and LD5V for WS position sensors



PP24V Incremental 	Output	Push-pull line driver (24 V - HTL)
	Excitation voltage	10 ... 30 V DC
	Excitation current	150 mA max. w/o load
	Output frequency	300 kHz max.
	Output current	100 mA per channel
	Signal level	
	Ud High at Id=20 mA, Ub=24 V	≥21 V
	Ud Low at Id=20 mA, Ub=24 V	≤2,8 V
	Transition time positive edge	< 200 ns
	Transition time negative edge	< 200 ns
	Stability (Temperature)	±20 x 10 ⁻⁶ / °C full scale (sensor mechanism)
	Operation temperature	-20 ... +85 °C
	Protection	Short circuit, overvoltage, reverse polarity
	EMC)	According to EN 61326:2004

LD5V Incremental 	Output	Line driver according to RS-422
	Excitation voltage	5 V DC ± 10%
	Excitation current	150 mA max. w/o load
	Output frequency	300 kHz max.
	Output current	20 mA per channel
	Signal level	
	Ud High at Id=20 mA	≥2,5 V
	Ud Low at Id=20 mA	≤0,5 V
	Transition time positive edge	< 100 ns
	Transition time negative edge	< 100 ns
	Stability (Temperature)	±20 x 10 ⁻⁶ / °C full scale (sensor mechanism)
	Operation temperature	-20 ... +85 °C
	Protection	Short circuit, overvoltage
	EMC	According to EN 61326:2004

Output circuit and recommended processing input circuit

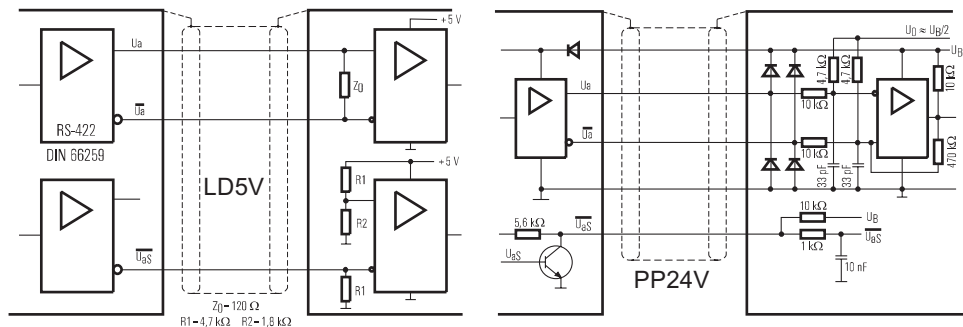

Output signals and output connectors

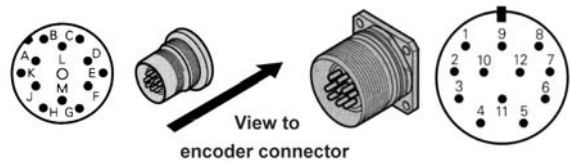
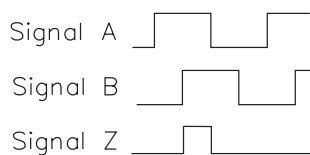

Signal wiring and connection	Output signals (Note: Do not connect pins not listed in this table)	WS19KT:	WS19KK:
		CONN-DIN-12F-W	CONN-CONIN-12F-G
Excitation +		M	12
Excitation GND (0V)		K	10
Signal A		E	5
Signal \bar{A}		F	6
Signal B		H	8
Signal \bar{B}		A	1
Signal Z (reference pulse)		C	3
Signal \bar{Z}		D	4
Fault detection signal \bar{U}_{as}		G	7
Shield		Housing	Housing

Output Specification for absolute encoders with SSI interface



Signal Conditioner HSSI Absolute Encoder synchronous serial 	Excitation voltage	10 ... 30 V DC
	Excitation current	100 mA
	Interface	Standard SSI
	Lines / drivers	Clock and data / RS-422
	Code	Gray
	Resolution multiturn	12 + 12 bit
	3 dB cutoff frequency	500 kHz
	Control input	Direction
	Alarm output	Alarm bit (SSI option), warning bit
	Status LED	Green = OK, red = alarm
	Connection	Cable or male socket 12 pin

Data format	Resolution	Clock												
		T1 T2 T3 ... T12 T13 ... T21 T22 T23 T24 T25 T26												
		Data bits												
	24 bit	M11 M10 M9 ... M0 S11 ... S3 S2 S1 S0 0												

Mx = multiturn bits, Sx = single turn bits

Transmission rate	Cable length	Baud rate	Note: Extension of the cable length will reduce the maximum transmission rate. The signals <u>CLOCK/CLOCK</u> and <u>DATA/DATA</u> must be connected in a twisted pair cable, shielded per pair and common.
	< 50 m	< 400 kHz	
	< 100 m	< 300 kHz	
	< 200 m	< 200 kHz	
	< 400 m	< 100 kHz	

Signal Wiring / Connection	Signal names	Color	Connector pin no.
	Excitation +	white	8
	Excitation GND (0V)	brown	1
	CLOCK	yellow	3
	CLOCK	green	11
	DATA	pink	2
	DATA	grey	10
	Direction *	blue	5
	0 V signal output	black	12

* Excitation + = cw increasing code, 0 V = cw decreasing code

Connection Mating Connector

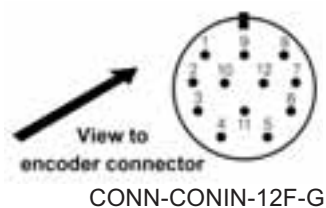

Output Specification for absolute encoders with programmable SSI interface



Programmable Signal Conditioner HSSI Absolute Encoder synchronous serial 	Excitation voltage	10 ... 30 V DC
	Excitation current	250 mA
	Interface	SSI programmable
	Lines/drivers	Clock and data / RS-422
	Code	Binary or Gray, programmable
	Resolution	13 (9 ... 20 bit) + 12 bit
	Format	MSB justified or fir tree
	Programmability	Resolution, code, rotating direction, format, warning, alarm
	Control input	Direction, Preset1, Preset2
	Reset button under housing cover	Lockable by programming
	Alarm output	Alarm bit (SSI option), warning bit
	Status LED	Green = ok, red = alarm
	Connection	Cable or male socket 12 pin

Transmission rate	Cable length	Baud rate	Note: Extension of the cable length will reduce the maximum transmission rate. The signals CLOCK/CLOCK and DATA/DATA must be connected in a twisted pair cable, shielded per pair and common.
	< 50 m	< 400 kHz	
	< 100 m	< 300 kHz	
	< 200 m	< 200 kHz	
	< 400 m	< 100 kHz	

Signal Wiring / Connection	Signal names	Color	CONN-CONIN-12F
	Excitation +	white *	11
	Excitation GND (0V)	brown *	12
	CLOCK	yellow	2
	CLOCK	green	1
	DATA	pink	3
	DATA	grey	4
	Direction	blue	8
	0 V signal output	black	7
	RS-232 TxD	brown	5
	RS-232 RxD	white	6
	Preset 1	red	9
	Preset 2	violet	10

* = larger width 0,5 mm²

Connection Mating Connector

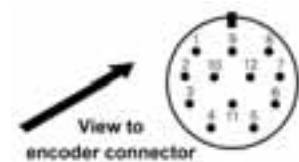

CONN-CONIN-12F-G

Output Specification for absolute encoders with Profibus interface



Interface HPROF Absolute Encoder Profibus 	Excitation voltage	10 ... 30 V DC
	Excitation current	250 mA
	Interface	RS-485
	Protocol	Profibus DP with encoder profile class C2
	Resolution	12 (10 ... 14) + 12 bit
	Output code	Binary
	Baudrate	Automatically selected between 9,6 kBaud and 12 MBaud
	Programmability	Resolution, preset, direction
	Integrated special functions	Velocity, acceleration, operating time
	Bus terminating resistor	Selectable via DIP switch
	Connection	Bus cover with T-manifold
	EMC	EN61326 : class A

Signal Wiring / Connection	Signal name	Cable terminal no. (bus cover)
	UB in	1
	0V in	2
	UB out	3
	0V out	4
	B in	5
	A in	6
	B out	7
	A out	8

Output Specification for absolute encoders with Parallel interface



Interface HPAR Absolute Encoder Parallel 	Excitation voltage	10 ... 30 V DC
	Excitation current	300 mA
	Interface	Parallel
	Output code	Binary, Gray, Gray Excess
	Resolution	12 bit + 12 bit
	Output current	30 mA per bit short circuit protected
	Alarm output	NPN open collector 5 mA max.
	Control inputs	Latch, Direction, Tristate
	Connection	Cable 0.1 m with SUB-D 37 pin connector

Control inputs	Input name	Level (physical)	Function
	Direction	1 (+UB or open input)	CW increasing code values
		0 (0 V)	CW decreasing code values
	Latch	1 (+UB or open input) 0 (0 V)	Encoder data free running Encoder data stored (data hold)
	Tristate	1 (+UB)	Outputs in tristate condition
		0 (0 V or open input)	Outputs active

Switching delay 10 μs typ. for push-pull operation, for open collector signals an external pull-down resistor (1 kΩ) is necessary.

Signal Wiring / Connection	Signal names	Color	Connector SUB-D 37 pin	
	S0	brown	2	
	S1	green	21	
	S2	yellow	3	
	S3	grey	22	
	S4	pink	4	
	S5	violet	23	
	S6	Singleturn bits	grey/pink	5
	S7		red/blue	24
	S8	white/green	6	
	S9	brown/green	25	
	S10	white/yellow	7	
	S11	yellow/brown	26	
	M0	Multiturn bits	white/grey	8
	M1		grey/brown	27
	M2		white/pink	9
	M3		pink/brown	28
	M4		white/blue	14
	M5		brown/blue	33
	M6		white/red	15
	M7		brown/red	34
	M8		white/black	16
	M9		brown/black	35
	M10		grey/green	17
	M11	yellow/grey	36	
	Alarm		pink/green	18
	Direction		yellow/pink	10
Latch		green/blue	30	
Tristate		yellow/blue	12	
10...30 V DC		red (0.5 mm2)	13	
10...30 V DC		white (0.5 mm2)	31	
0 V		blue (0.5 mm2)	1	
0 V		black (0.5 mm2)	20	

Connection Mating Connector

View to encoder connector

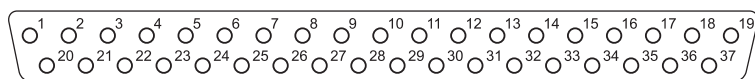

CONN-SUBD-37F

Output Specification for absolute encoders with Interbus interface



Interface HINT Absolute Encoder Interbus 	Excitation voltage	10 ... 30 V
	Excitation current	250 mA
	Interface	Interbus, ENCOM Profile K3 (programmable), K2
	Output code	Binary 32 bit
	Baud rate	500 kBaud
	Data refresh	Every 600 µs
	Resolution	12 (10 ... 12) + 12 bit
	Programmability	Direction, preset, offset, resolution
	Connection	Bus cover with T-manifold
	EMC	EN 50081-2, 50082-2

Data format Interbus K2		Differential signals (RS485) ENCOM profile K3, K2, 32 bit, binary process data				
	DT format	S _{mpi} address	0	1	2	3
	(according to the Phoenix company)	Byte no.	3	2	1	0
	ID code K2		36 H (= 54 dec.)			
	ID code K3		37 H (= 55 dec.)			

Signal wiring / connection	Signal names	Cable terminal no. (bus cover)
		UB +
	GND	2
	DI1	3
	DI1	4
	DO1	5
	DO1	6
	DO2	7
	DO2	8
	DI2	9
	DI2	10
	RBST	11
	GND	12

Output Specification for absolute encoders with DeviceNet interface



Interface HDEV Absolute Encoder DeviceNet 	Excitation voltage	10 ... 30 V DC
	Excitation Current	250 mA
	Interface	CAN highspeed according ISO/DIS 11898 CAN specification 2.0 A (11 bit identifier)
	Protocol	DeviceNet according to Rev. 2.0, programmable encoder
	Resolution	12 (10 ... 14) + 12 bit
	Programmable	Resolution, preset, direction
	Output code	Binary
	MAC ID	Selectable via DIP switch
	Data refresh	Every 5 ms
	Baud rate	Selectable 125, 250, 500 kBaud, DIP switch
	Bus terminating resistor	Selectable via DIP switch
	Connection	Bus cover with T-manifold
	EMC	EN 50081-2, 50082-2

Recommended transmission	Characteristic impedance	135 ... 165 Ω (3...20 MHz)
	Operating capacity	< 30 pF
	Loop resistance	< 110 Ω /km
	Wire diameter	> 0.63 mm
	Wire width	> 0.34 mm ²

Transmission rate	Segment length	Kbit/s
	500 m	125
	250 m	250
	100 m	500

Signal Wiring / Connection	Signal name	Cable terminal no. (bus cover)
	UB in	1
	0V in	2
	CAN-L	3
	CAN-H	4
	Drain	5
	Drain	6
	CAN-H	7
CAN-L	8	

Output Specification for absolute encoders with CAN interface



Interface HCAN/HCANOP Absolute Encoder CANopen/CAN Layer 2 	Excitation voltage	10 ... 30 V DC
	Excitation current	250 mA
	Interface	CAN highspeed according ISO/DIS 11898
	Protocol	CANopen according to DS301 with encoder profile DSP 406, programmable encoder according to class 2
	Resolution	12 (10 ... 14) + 12 bit
	Programmable	CANopen: direction, resolution, preset, offset; CAN L2: direction, limit values
	Output code	Binary
	Data refresh	Every millisecond (adjustable), on request
	Baud rate	Selectable 10 to 1000 kBaud
	Base identifier	Selectable via DIP switches
	Integrated special functions	CANopen: speed, acceleration, limit values CAN L2: direction, limit values
	Connection	Bus cover with T-manifold
	EMC	EN 50081-2, EN50082-2

Signal wiring / connection	Signal names	Cable terminal no. (bus cover)
	UB in	1
	0V in	2
	CAN in – (dominant L)	3
	CAN in + (dominant H)	4
	CAN GND in	5
	CAN GND out	6
	CAN out + (dominant H)	7
	CAN out - (dominant L)	8
	0V out	9
	UB out	10