

isc Silicon NPN Power Transistor

2SC3254

DESCRIPTION

- Low Collector Saturation Voltage
- Good Linearity of h_{FE}
- High Switching Speed
- Complement to Type 2SA1290

APPLICATIONS

- Various inductance lamp drivers for electrical equipment
- Inverters, converters
- Power amplifier
- Switching regulator, driver

ABSOLUTE MAXIMUM RATINGS($T_a=25^{\circ}C$)

SYMBOL	PARAMETER	VALUE	UNIT
V_{CBO}	Collector-Base Voltage	80	V
V_{CEO}	Collector-Emmitter Voltage	60	V
V_{EBO}	Emitter-Base Voltage	5	V
I_C	Collector Current-Continuous	7	A
I_{CM}	Collector Current-Pulse	10	A
P_C	Collector Power Dissipation @ $T_C=25^{\circ}C$	35	W
T_J	Junction Temperature	150	$^{\circ}C$
T_{stg}	Storage Temperature Range	-55~150	$^{\circ}C$

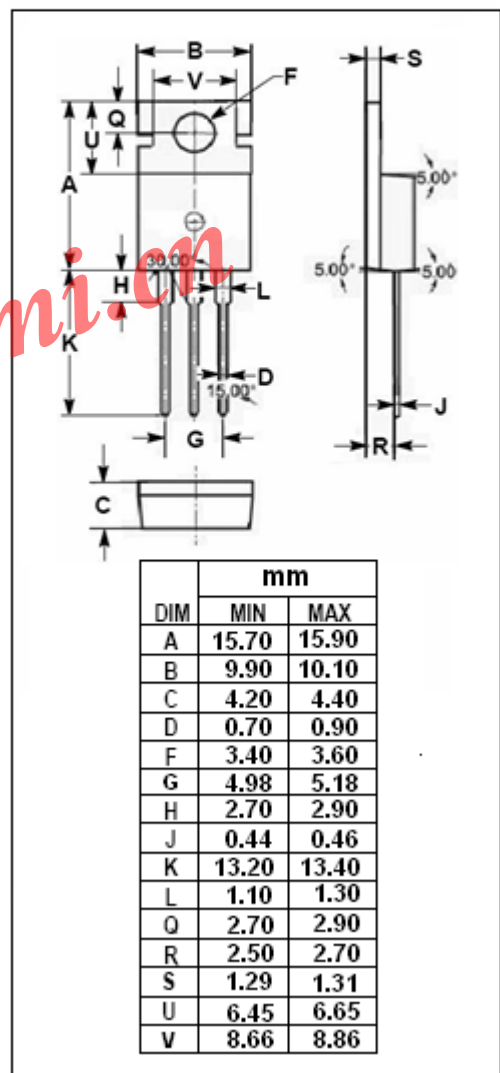
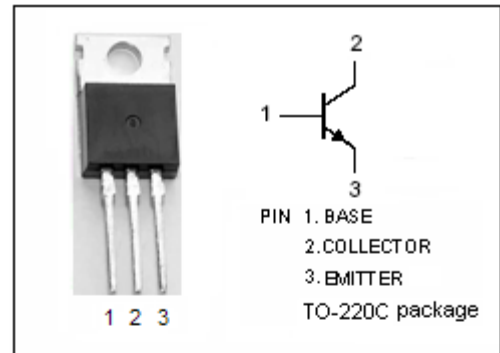

isc Silicon NPN Power Transistor

2SC3254

ELECTRICAL CHARACTERISTICS

 $T_C=25^\circ\text{C}$ unless otherwise specified

SYMBOL	PARAMETER	CONDITIONS	MIN	TYP.	MAX	UNIT
$V_{(BR)CEO}$	Collector-Emitter Breakdown Voltage	$I_C=1\text{mA}; R_{BE}=\infty$	60			V
$V_{(BR)CBO}$	Collector-Base Breakdown Voltage	$I_C=1\text{mA}; I_E=0$	80			V
$V_{(BR)EBO}$	Emitter-Base Breakdown Voltage	$I_E=1\text{mA}; I_C=0$	5			V
$V_{CE(sat)}$	Collector-Emitter Saturation Voltage	$I_C=3.5\text{A}; I_B=0.175\text{A}$			0.4	V
I_{CBO}	Collector Cutoff Current	$V_{CB}=40\text{V}; I_E=0$			100	μA
I_{EBO}	Emitter Cutoff Current	$V_{EB}=4\text{V}; I_C=0$			100	μA
h_{FE}	DC Current Gain	$I_C=1\text{A}; V_{CE}=2\text{V}$	70		280	
f_T	Current-Gain—Bandwidth Product	$I_C=1\text{A}; V_{CE}=5\text{V}$		100		MHz

Switching times

t_{on}	Turn-on Time	$I_C=3\text{A}; I_{B1}=-I_{B2}=0.15\text{A}; R_L=6.67\Omega; V_{CC}=20\text{V}$		0.1		μs
t_{stg}	Storage Time			0.5		μs
t_f	Fall Time			0.1		μs

◆ h_{FE} Classifications

Q	R	S
70-140	100-200	140-280