

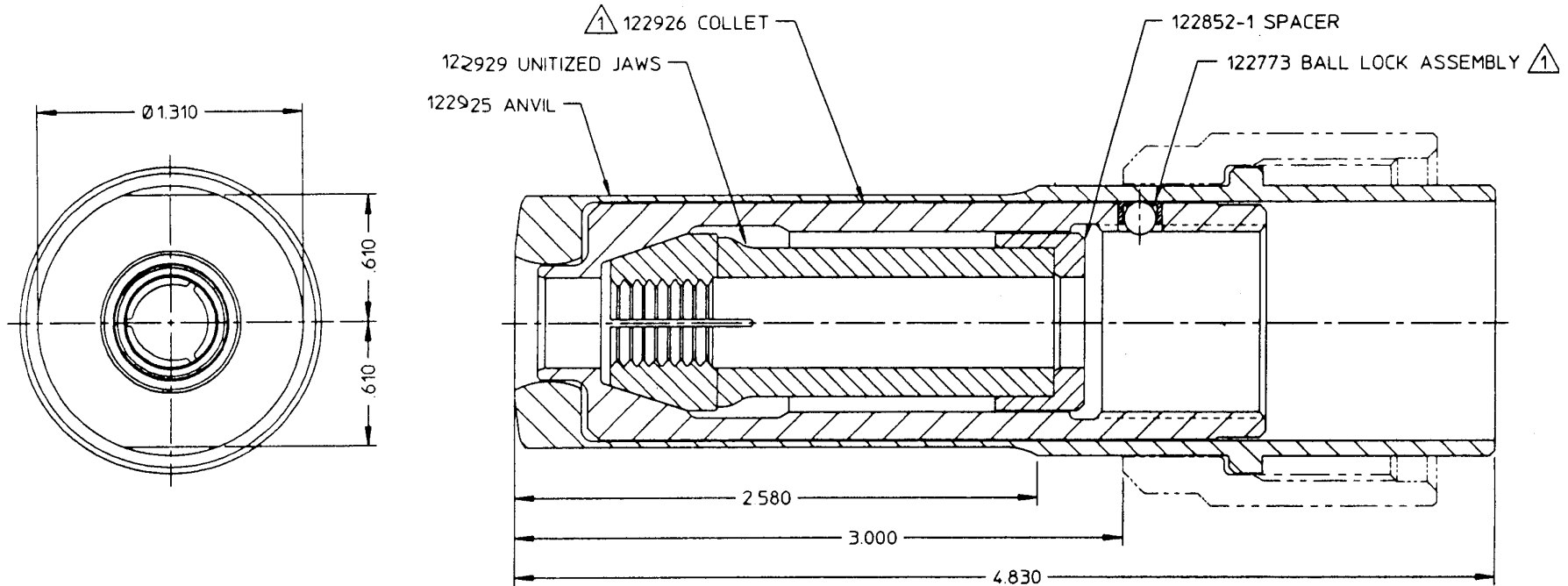

**Huck
Fasteners**

From Cordant Technologies

NOSE ASSEMBLY DATA SHEET



©Huck International, Inc. 1995
 ©Registered Trademark of Huck International, Inc., Irvine, CA
 ™Trademark of Huck International, Inc., Irvine, CA

**Yellow band on anvils of
LGP® fasteners.**

NOTES:

- △ COLLET & LOCK ASSEMBLY P/N 122927
 CONSISTS OF:
 122926 COLLET
 122773 BALL LOCK ASSEMBLY
 NOT AVAILABLE SEPARATELY.

U.S. Patent No. 4,347,728

99-2657	NOSE ASSEMBLY	Huck International, Inc. Installation System Division 1 Corporate Drive - Kingston, NY 12401	
		TYPE: Non-Self-releasing, Short FOR: HUCKBOLT LGP -14 TOOL: 2600	
OTHER		ISSUED:	2-93
		REVISED:	

Nose Assembly Maintenance

1. Prepare tool per manual. Blind fasteners require pintail tube, 122771 - - also use tube if pintails of any other type fasteners will drop through tube.

WARNING

Before maintenance or adjustments, POWERIG Hydraulic Unit must be disconnected from electrical or air supply. If not disconnected, severe personal injury and/or damage may result.

Disconnect POWERIG Hydraulic Unit's power source. Connect tool's hoses and controls to unit. Reconnect power source. Depress trigger for 30 seconds piston stops completely forward. Disconnect controls and RETURN hose - - tool piston must remain completely forward.

2. Disassembly/assembly as applies:
Remove parts of nose assembly for inspection and maintenance.

Anvil:

Where used, pressed-in anvil insert is pressed out with drift and arbor press - - press new anvil in squarely to prevent cracking.

Collet:

Check to be sure brass locking ball is not missing or worn - - press new lock assembly squarely into collet. After collet bottoms out on tool's piston rod, put thumb pressure on brass ball and turn collet slowly until ball drops in groove.

CAUTION: Do not turn collet past first groove.

Attaching anvil:

Push anvil over collet. Install tool's retaining nut hand-tight.

3. Checking nose assembly:

See WARNING connect controls and RETURN hose. Reconnect hydraulic unit to power source. Install fasteners in test plate of correct thickness with proper size holes check pintail ejection and installed fasteners.

Notes:

1. *To extend jaw life:*

Disassemble nose assembly periodically; clean and inspect components - - use a pick to clean jaw grooves. **CAUTION:** Wash parts in **mineral spirits or isopropyl alcohol** only dry urethane (UNITIZED) jaw assemblies **immediately** after cleaning as prolonged contact with solvent causes swelling dry other parts.

2. *Spare parts - - as applicable:* Collet locks; jaws; driving anvils.

3. *Tool/service items as applicable:*

Adjustable wrench, 503044; VIBRATITE, 505125 (if applicable, for collet extension); 7/16 hex key, 505898, for tool piston.