

Silicon PNP Darlington Power Transistors

2SB1558

DESCRIPTION

- With TO-3PI package
- Complement to type 2SD2387

APPLICATIONS

- For power amplifier applications

PINNING

PIN	DESCRIPTION
1	Base
2	Collector;connected to mounting base
3	Emitter

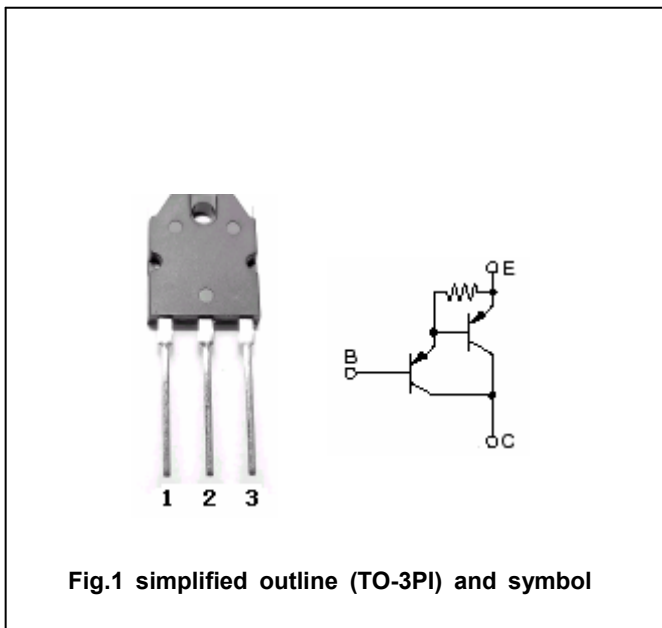

Fig.1 simplified outline (TO-3PI) and symbol

Absolute maximum ratings(Ta=□)

SYMBOL	PARAMETER	CONDITIONS	VALUE	UNIT
V _{CBO}	Collector-base voltage	Open emitter	-140	V
V _{CEO}	Collector-emitter voltage	Open base	-140	V
V _{EBO}	Emitter-base voltage	Open collector	-5	V
I _C	Collector current		-8	A
I _B	Base current		-0.1	A
P _C	Collector power dissipation	T _C =25□	80	W
T _j	Junction temperature		150	□
T _{stg}	Storage temperature		-55~150	□

Silicon PNP Darlington Power Transistors

2SB1558

CHARACTERISTICS

T_j=25 °C unless otherwise specified

SYMBOL	PARAMETER	CONDITIONS	MIN	TYP.	MAX	UNIT
V _{(BR)CEO}	Collector-emitter breakdown voltage	I _C =-50mA ; I _B =0	-140			V
V _{CEsat}	Collector-emitter saturation voltage	I _C =-7A ; I _B =-7mA			-2.5	V
V _{BE}	Base-emitter on voltage	I _C =-7A ; V _{CE} =-5V			-3.0	V
I _{CBO}	Collector cut-off current	V _{CB} =-140V ; I _E =0			-5	μA
I _{EBO}	Emitter cut-off current	V _{EB} =-5V ; I _C =0			-5	μA
h _{FE-1}	DC current gain	I _C =-7A ; V _{CE} =-5V	5000		30000	
h _{FE-2}	DC current gain	I _C =-12A ; V _{CE} =-5V	2000			
C _{ob}	Output capacitance	I _E =0 ; V _{CB} =-10V ; f=1MHz		170		pF
f _T	Transition frequency	I _C =-1A ; V _{CE} =-5V		30		MHz

◆ h_{FE-1} Classifications

A	B	C
5000-12000	9000-18000	15000-30000

Silicon PNP Darlington Power Transistors

2SB1558

PACKAGE OUTLINE

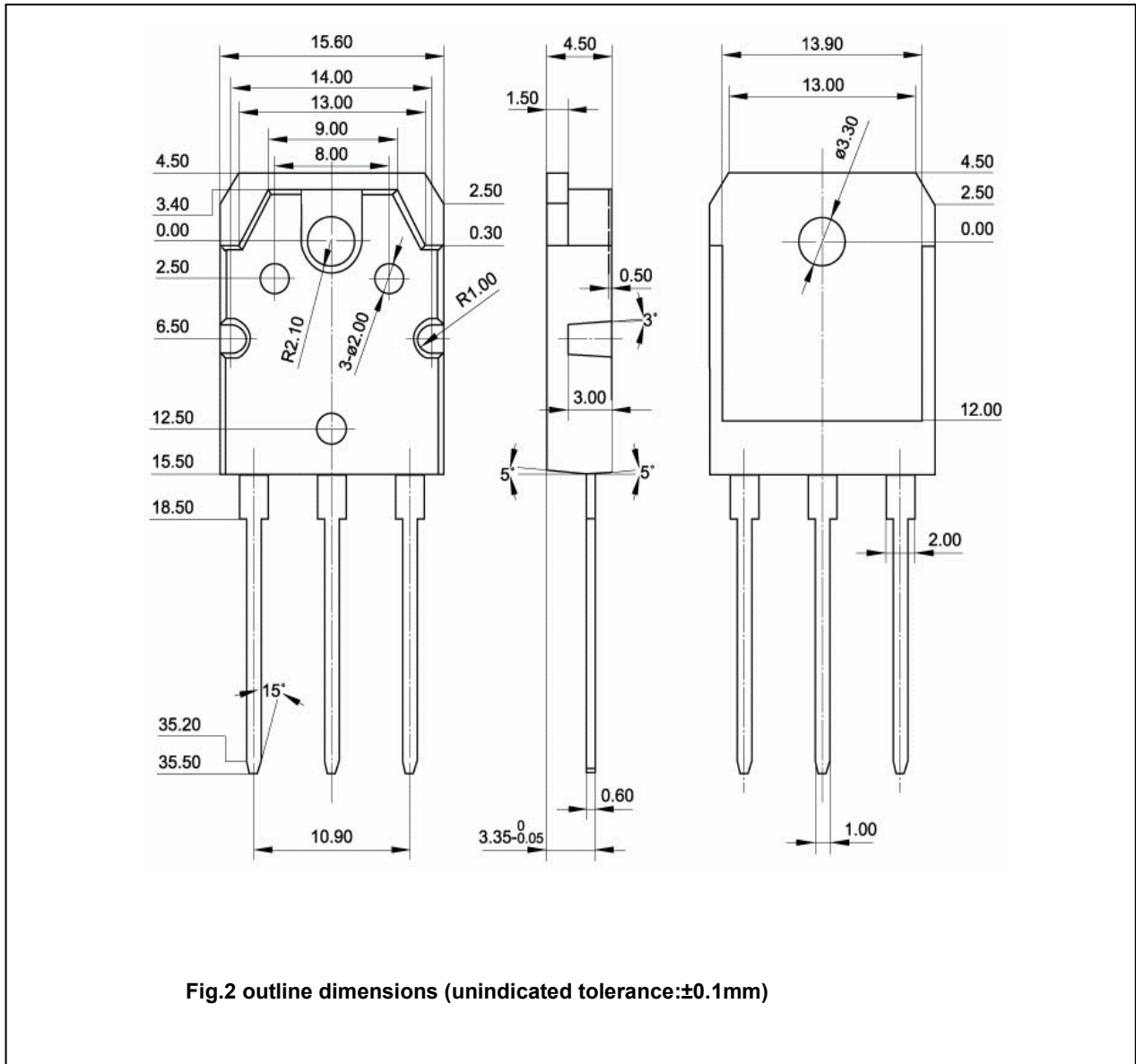

Fig.2 outline dimensions (unindicated tolerance:±0.1mm)