

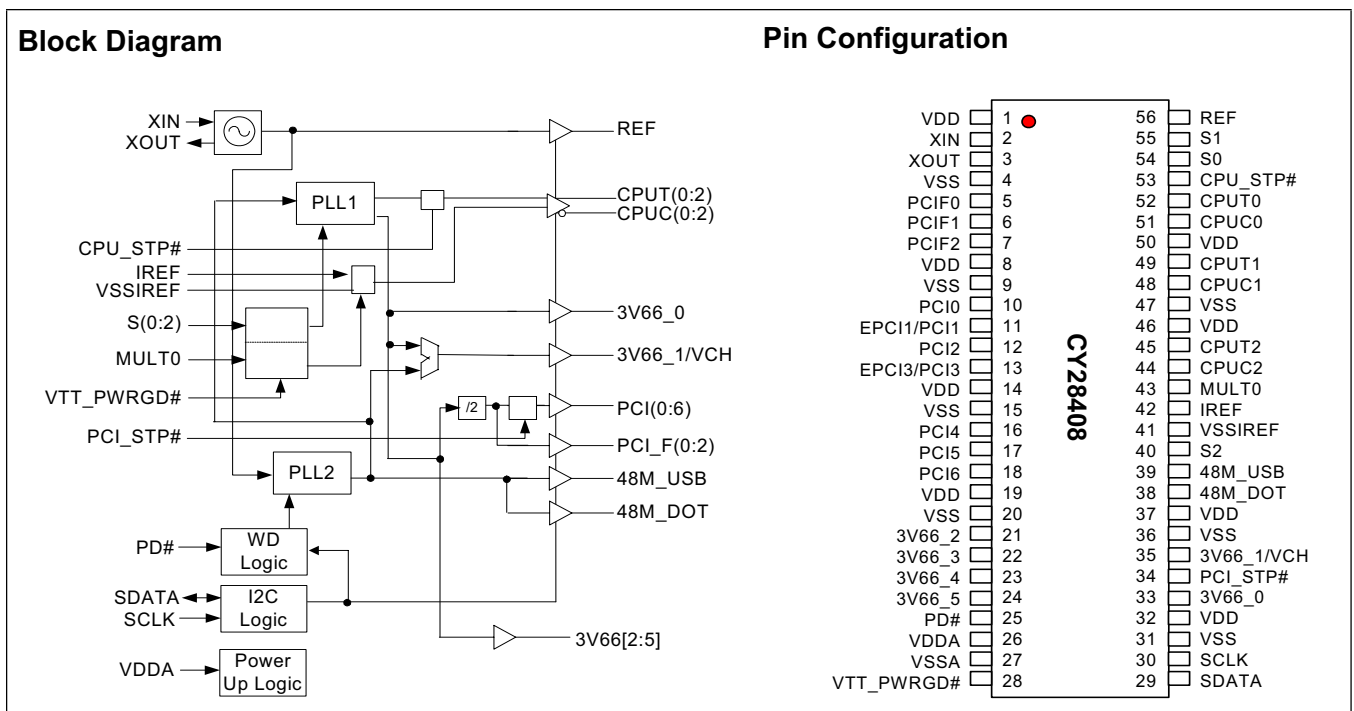
Clock Synthesizer with Differential CPU Outputs

Features

- Compatible to Intel® CK 408 Mobile Clock Synthesizer
- Support Intel P4 and Brookdale CPU
- Specifications
- 3.3V power supply
- Three differential CPU clocks
- Ten copies of PCI clocks
- Six copies of 3V66 clocks
- SMBus support with read back capabilities
- Spread Spectrum electromagnetic interference (EMI) reduction
- Dial-A-Frequency® features
- Dial-A-dB™ features
- 56-pin TSSOP package

Table 1. Frequency Table^[1]

S2	S1	S0	CPU(0:2)	3V66	PCI_PCIF	REF	USB/DOT	
1	0	0	100 MHz	66 MHz	33 MHz	14.318 MHz	48 MHz	
1	0	1	133 MHz	66 MHz	33 MHz	14.318 MHz	48 MHz	
1	1	0	Reserved					
1	1	1	166 MHz	66 MHz	33 MHz	14.318 MHz	48 MHz	
0	0	0	66 MHz	66 MHz	33 MHz	14.318 MHz	48 MHz	
0	0	1	100 MHz	66 MHz	33 MHz	14.318 MHz	48 MHz	
0	1	0	Reserved					
0	1	1	133 MHz	66 MHz	33 MHz	14.318 MHz	48 MHz	
M	0	0	Hi-Z	Hi-Z	Hi-Z	Hi-Z	Hi-Z	
M	0	1	TCLK/2	TCLK/4	TCLK/8	TCLK	TCLK/2	



Note:

1. TCLK is a test clock driven on the XTAL_IN input during test mode. M = driven to a level between 1.0V and 1.8V. If the S2 pin is at a M level during power-up, an 0 state will be latched into the device's internal state register.

Pin Description

Pin	Name	PWR	I/O	Description
2	XIN	VDD	I	Oscillator buffer input. Connect to a crystal or to an external clock.
3	XOUT	VDD	O	Oscillator buffer output. Connect to a crystal. Do not connect when an external clock is applied at XIN.
52, 51, 49, 48, 45, 44	CPUT(0:2), CPUC(0:2)	VDD	O	Differential host output clock pairs. See <i>Table 1</i> for frequencies and functionality.
10, 12, 16, 17, 18	PCI(0,2)/(3:5)	VDDP	O	PCI clock outputs. Synchronous to the 3V66 clock. See <i>Table 1</i> .
11, 13	EPCI/PCI(1,3)	VDD	I/O PD	Early or normal PCI clock outputs. There is an internal 250k Ω pull-down resistor. See <i>Table 8</i> .
5, 6, 7	PCIF (0:2)	VDD	O	33-MHz PCI clocks, which are ± 2 copies of 3V66 clocks, may be free running (not stopped when PCI_STP# is asserted LOW) or may be stoppable depending on the programming of SMBus register Byte3, Bits (3:5).
56	REF	VDD	O	Buffered output copy of the device's XIN clock.
42	IREF	VDD	I	Current reference programming input for CPU buffers. A resistor is connected between this pin and VSSIREF.
28	VTT_PWRGD#	VDD	I	Qualifying input that latches S(0:2) and MULT0. When this input is at a logic low, the S(0:2) and MULT0 are latched
39	48M_USB	VDD48	O	Fixed 48-MHz USB clock outputs.
38	48M_DOT	VDD48	O	Fixed 48-MHz DOT clock outputs.
33	3V66_0	VDD	O	3.3V 66-MHz fixed frequency clock.
35	3V66_1/VCH	VDD	O	3.3V clock selectable with SMBus byte0, Bit5, when Byte5, Bit5. When Byte 0 Bit 5 is at a logic 1, then this pin is a 48M output clock. When byte0, Bit5 is a logic 0, then this is a 66-MHz output clock (default).
21, 22, 23, 24	3V66(2:5)	VDD	O	3.3V 66-MHz fixed frequency clock.
25	PD#	VDD	I PU	This pin is a power-down mode pin. A logic LOW level causes the device to enter a power-down state. All internal logic is turned off except for the SMBus logic. All output buffers are stopped.
43	MULT0	VDD	I PU	Programming input selection for CPU clock current multiplier. 0 = 4 * IREF, 1 = 6 * IREF
55, 54	S(0,1)	VDD	I	Frequency select inputs. See <i>Table 1</i>
29	SDATA	VDD	I/O PU	Serial data input. Conforms to the SMBus specification of a Slave Receive/Transmit device. It is an input when receiving data. It is an open drain output when acknowledging or transmitting data.
30	SCLK	VDD	I PU	Serial clock input. Conforms to the SMBus specification.
40	S2	VDD	I T	Frequency select input. See <i>Table 1</i> . This is a tri-level input that is driven HIGH, LOW, or driven to an intermediate level.
34	PCI_STP#	VDD	I PU	PCI clock disable input. When asserted LOW, PCI (0:6) clocks are synchronously disabled in a LOW state. This pin does not effect PCIF (0:2) clock outputs if they are programmed to be PCIF clocks via the device's SMBus interface.
53	CPU_STP#	VDD	I PU	CPU clock disable input. When asserted LOW, CPUT (0:2) clocks are synchronously disabled in a HIGH state and CPUC(0:2) clocks are synchronously disabled in a LOW state.
1, 8, 14, 19, 32, 37, 46, 50	VDD	–	PWR	3.3V power supply.
4, 9, 15, 20, 27, 31, 36, 47	VSS	–	PWR	Common ground.
41	VSSIREF	–	PWR	Current reference programming input for CPU buffers. A resistor is connected between this pin and IREF. This pin should also be returned to device VSS.
26	VDDA	–	PWR	Analog power input. Used for PLL and internal analog circuits. It is also specifically used to detect and determine when power is at an acceptable level to enable the device to operate.

Serial Data Interface

To enhance the flexibility and function of the clock synthesizer, a two-signal serial interface is provided. Through the Serial Data Interface, various device functions, such as individual clock output buffers, can be individually enabled or disabled. The registers associated with the Serial Data Interface initialize to their default setting upon power-up, and therefore use of this interface is optional. Clock device register changes are normally made upon system initialization, if any are required. The interface can also be used during system operation for power management functions.

Table 2. Command Code Definition

Bit	Description
7	0 = Block read or block write operation, 1 = Byte read or byte write operation
(6:0)	Byte offset for byte read or byte write operation. For block read or block write operations, these bits should be '0000000'

Data Protocol

The clock driver serial protocol accepts block write and block read operations from the controller. For block write/read operation, the bytes must be accessed in sequential order from lowest to highest byte (most significant bit first) with the ability to stop after any complete byte has been transferred.

The block write and block read protocol is outlined in *Table 3* while *Table 4* outlines the corresponding byte write and byte read protocol. The slave receiver address is 11010010 (D2h).

Table 3. Block Read and Block Write Protocol

Block Write Protocol		Block Read Protocol	
Bit	Description	Bit	Description
1	Start	1	Start
8:2	Slave address – 7 bits	8:2	Slave address – 7 bits
9	Write	9	Write
10	Acknowledge from slave	10	Acknowledge from slave
18:11	Command Code – 8 Bits	18:11	Command Code – 8 Bits
19	Acknowledge from slave	19	Acknowledge from slave
27:20	Byte Count – 8 bits (Skip this step if I ² C_EN bit set)	20	Repeat start
28	Acknowledge from slave	27:21	Slave address – 7 bits
36:29	Data byte 1 – 8 bits	28	Read = 1
37	Acknowledge from slave	29	Acknowledge from slave
45:38	Data byte 2 – 8 bits	37:30	Byte Count from slave – 8 bits
46	Acknowledge from slave	38	Acknowledge
....	Data Byte /Slave Acknowledges	46:39	Data byte 1 from slave – 8 bits
....	Data Byte N –8 bits	47	Acknowledge
....	Acknowledge from slave	55:48	Data byte 2 from slave – 8 bits
....	Stop	56	Acknowledge
		Data bytes from slave / Acknowledge
		Data Bte N from slave – 8 bits
		NOT Acknowledge
		...	Stop

Table 4. Byte Read and Byte Write Protocol

Byte Write Protocol		Byte Read Protocol	
Bit	Description	Bit	Description
1	Start	1	Start
8:2	Slave address – 7 bits	8:2	Slave address – 7 bits
9	Write	9	Write
10	Acknowledge from slave	10	Acknowledge from slave
18:11	Command Code – 8 bits	18:11	Command Code – 8 bits

Table 4. Byte Read and Byte Write Protocol (continued)

Byte Write Protocol		Byte Read Protocol	
Bit	Description	Bit	Description
19	Acknowledge from slave	19	Acknowledge from slave
27:20	Data byte – 8 bits	20	Repeated start
28	Acknowledge from slave	27:21	Slave address – 7 bits
29	Stop	28	Read
		29	Acknowledge from slave
		37:30	Data from slave – 8 bits
		38	NOT Acknowledge
		39	Stop

Byte 0: CPU Clock Register^[2]

Bit	@Pup	Name	Description
7	0		Spread Spectrum Enable, 0 = Spread Off, 1 = Spread On This is a Read and Write control bit.
6	0		CPU clock Power-down Mode Select. 0 = Drive CPUT to 4 or 6 IREF and drive CPUC to low when PD# is asserted LOW. 1 = Three-state all CPU outputs. This is only applicable when PD# is LOW. It is not applicable to CPU_STP#.
5	0	3V66_1/VCH	3V66_1/VCH frequency Select, 0 = 66M selected, 1 = 48M selected This is a Read and Write control bit.
4	Pin 53	CPU_STP#	Reflects the current value of the external CPU_STP#. This bit is Read-only.
3	Pin 34	PCI_STP#	Reflects the current value of the internal PCI_STP# function when read. Internally PCI_STP# is a logical AND function of the internal SMBus register bit and the external PCI_STP# pin. This is a Read and Write control bit.
2	Pin 40	SEL2	Frequency Select Bit 2. Reflects the value of SEL2. This bit is Read-only.
1	Pin 55	SEL1	Frequency Select Bit 1. Reflects the value of SEL1. This bit is Read-only.
0	Pin 54	SEL0	Frequency Select Bit 0. Reflects the value of SEL0. This bit is Read-only.

Byte 1: CPU Clock Register

Bit	@Pup	Name	Description
7	Pin 43		MULT0 Value. This bit is Read-only.
6	0		Controls functionality of CPUT/C outputs when CPU_STP# is asserted. 0 = Drive CPUT to 4 or 6 IREF and drive CPUC to low when CPU_STP# is asserted LOW. 1 = Tri-state all CPU outputs when CPU_STP# is asserted. This bit will override Byte0, Bit6 such that even if it is a 0, when PD# goes low the CPU outputs will be tri-stated.
5	0		Controls CPU2 functionality when CPU_STP# is asserted LOW 1 = Free Running, 0 = Stopped LOW with CPU_STP# asserted LOW This is a Read and Write control bit.
4	0		Controls CPU1 functionality when CPU_STP# is asserted LOW 1 = Free Running, 0 = Stopped LOW with CPU_STP# asserted LOW This is a Read and Write control bit.
3	0		Controls CPUT0 functionality when CPU_STP# is asserted LOW 1 = Free Running, 0 = Stopped LOW with CPU_STP# asserted LOW This is a Read and Write control bit.
2	1	CPUT/C2	CPUT/C2 Output Control 1 = enabled, 0 = three-state CPUT/C2 This is a Read and Write control bit.

Note:

2. PU = Internal Pull-up. PD = Internal Pull-down. T = Tri-level logic input.

Byte 1: CPU Clock Register (continued)

Bit	@Pup	Name	Description
1	1	CPUT/C1	CPUT/C1 Output Control 1 = enabled, 0 = three-state CPUT/C1 This is a Read and Write control bit.
0	1	CPUT/C0	CPUT/C0 Output Control 1 = enabled, 0 = three-state CPUT/C0 This is a Read and Write control bit.

Byte 2: PCI Clock Control Register (all bits are read- and write-functional)

Bit	@Pup	Name	Description
7	0	REF	REF Output Control. 0 = high strength, 1 = low strength
6	1	PCI6	PCI6 Output Control 1 = enabled, 0 = forced LOW
5	1	PCI5	PCI5 Output Control 1 = enabled, 0 = forced LOW
4	1	PCI4	PCI4 Output Control 1 = enabled, 0 = forced LOW
3	1	PCI3	PCI3 Output Control 1 = enabled, 0 = forced LOW
2	1	PCI2	PCI2 Output Control 1 = enabled, 0 = forced LOW
1	1	PCI1	PCI1 Output Control 1 = enabled, 0 = forced LOW
0	1	PCI0	PCI0 Output Control 1 = enabled, 0 = forced LOW

Byte 3: PCI_F Clock and 48M Control Register (all bits are read- and write-functional)

Bit	@Pup	Name	Description
7	1	48M_DOT	48M_DOT Output Control 1 = enabled, 0 = forced LOW
6	1	48M_USB	48M_USB Output Control 1 = enabled, 0 = forced LOW
5	0		PCI_STP#, control of PCI_F2. 0 = Free Running, 1 = Stopped when PCI_STP# is LOW
4	0		PCI_STP#, control of PCI_F1. 0 = Free Running, 1 = Stopped when PCI_STP# is LOW
3	0		PCI_STP#, control of PCI_F0. 0 = Free Running, 1 = Stopped when PCI_STP# is LOW
2	1	PCI_F2	PCI_F2 Output Control 1 = running, 0 = forced LOW
1	1	PCI_F1	PCI_F1 Output Control 1 = running, 0 = forced LOW
0	1	PCI_F0	PCI_F0 Output Control 1 = running, 0 = forced LOW

Byte 4: 3V66 Control Register (all bits are read- and write-functional)

Bit	@Pup	Name	Description
7	0		SS2 Spread Spectrum control bit (0 = down spread, 1 = center spread)
6	0		Reserved
5	1	3V66_0	3V66_0 Output Enabled, 1 = enabled, 0 = disabled
4	1	3V66_1/VCH	3V66_1/VCH Output Enable 1 = enabled, 0 = disabled
3	1	3V66_5	3V66_5 Output Enable 1 = enabled, 0 = disabled
2	1	3V66_4	3V66_4 Output Enabled 1 = enabled, 0 = disabled
1	1	3V66_3	3V66_3 Output Enabled 1 = enabled, 0 = disabled
0	1	3V66_2	3V66_2 Output Enabled 1 = enabled, 0 = disabled

Byte 5: Spread Spectrum Control Register (all bits are read and write functional)

Bit	@Pup	Name	Description
7	0		SS1 Spread Spectrum control bit
6	1		SS0 Spread Spectrum control bit
5	0		Reserved
4	0		Reserved
3	0		Reserved
2	0		48M_DOT edge rate control. When set to 1, the edge is slowed by 40%.
1	0		Reserved
0	0		USB edge rate control. When set to 1, the edge is slowed by 40%.

Spread Spectrum Clock Generation (SSCG)

Spread Spectrum is a modulation technique used to minimizing EMI reduction generated by repetitive digital signals. A clock presents the generated EMI energy at the center frequency it is generating. Spread Spectrum distributes this energy over a specific and controlled frequency bandwidth therefore causing the average energy at any point in this band to decrease in value. This technique is achieved by modulating the clock away from its resting frequency by a certain percentage (which also determines the amount of EMI reduction). In this device, Spread Spectrum is enabled by setting specific register bits in the SMBus control bytes. *Table 5* is a listing of the modes and percentages of Spread Spectrum modulation that this device incorporates.

Table 5. Spread Spectrum

SS2	SS1	SS0	Spread Mode	Spread%
0	0	0	Down	+0.00, -0.25
0	0	1	Down	+0.00, -0.50
0	1	0	Down	+0.00, -0.75
0	1	1	Down	+0.00, -1.00
1	0	0	Center	+0.13, -0.13
1	0	1	Center	+0.25, -0.25
1	1	0	Center	+0.37, -0.37
1	1	1	Center	+0.50, -1.50

Byte 6: Silicon Signature Register (all bits are read-only)

Bit	@Pup	Name	Description
7	0	Revision ID Bit 3	Revision ID Bit 3
6	0	Revision ID Bit 2	Revision ID Bit 2
5	0	Revision ID Bit 1	Revision ID Bit 1
4	0	Revision ID Bit 0	Revision ID Bit 0
3	1	Vendor ID Bit 3	Vendor ID Bit 3
2	0	Vendor ID Bit 2	Vendor ID Bit 2
1	0	Vendor ID Bit 1	Vendor ID Bit 1
0	0	Vendor ID Bit 0	Vendor ID Bit 0

Byte 7: Reserved

Bit	@Pup	Name	Description
7	0		Reserved
6	0		Reserved
5	0		Reserved
4	0		Reserved
3	1		Reserved
2	1		Reserved
1	1		Reserved
0	0		N8, MSB

Byte 8: Dial-a-Frequency Control Register N (all bits are read and write functional)

Bit	@Pup	Name	Description
7	0		N7
6	0		N6
5	0		N5
4	0		N4
3	0		N3
2	0		N2
1	0		N3
0	0		N0, LSB

Byte 9: Dial-a-Frequency™ Control Register R (all bits are read and write functional)

Bit	@Pup	Name	Description
7	0		R6 MSB
6	0		R5
5	0		R4
4	0		R3
3	0		R2
2	0		R1
1	0		R0, LSB
0	0		R and N register mux selection. 0 = R and N values come from the ROM. 1 = data is loaded from DAF (SMBus) registers.

Dial-a-Frequency Feature

SMBus Dial-a-Frequency feature is available in this device via Byte8 and Byte9. See our App Note AN-0025 for details on our Dial-a-Frequency feature.

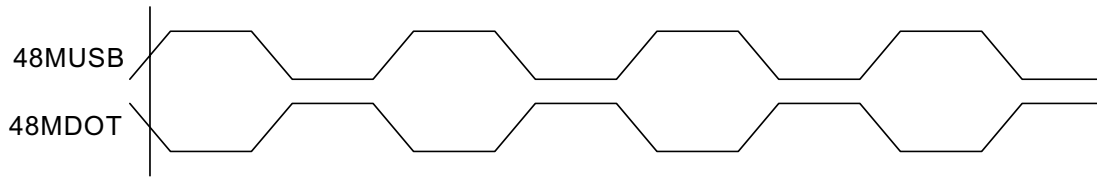
P is a large value PLL constant that depends on the frequency selection achieved through the hardware selectors (S1, S0). P value may be determined from *Table 6*.

Table 6. P Value

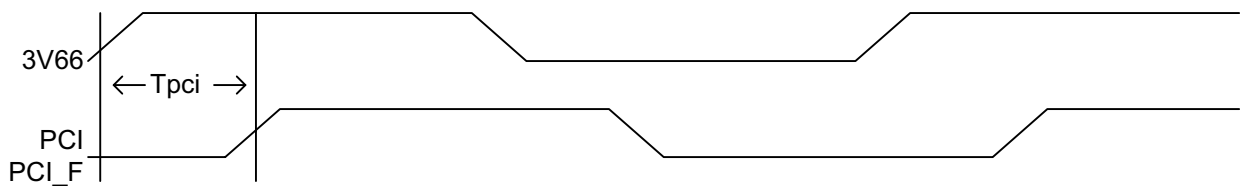
S(1:0)	P
0 0	32005333
0 1	48008000
1 0	96016000
1 1	64010667

USB and DOT 48M Phase Relationship

The 48M_USB and 48M_DOT clocks are normally in phase. It is understood that the difference in edge rate will introduce some inherent offset. When 3V66_1/VCH clock is configured for VCH (48-MHz) operation it is also in phase with the USB and DOT outputs. See *Figure 1*.


Figure 1. 48M_USB and 48M_DOT Phase Relationship
Table 7. Group Timing Relationship and Tolerances

Description	Offset	Tolerance	Conditions
3V66 to PCI	2.5 ns	±1.0 ns	3V66 Leads PCI
48M_USB to 48M_DOT Skew	0 or 10.4 ns	±1.0 ns	


Figure 2. 3V66 to PCI and PCI_F Phase Relationship
Table 8. Early PCI Select Functions^[3]

EPCI3	EPCI1	EPCI(3,1)
0	0	0.0 ns
1	0	0.8 ns
1	1	1.6 ns

Special Functions

PCI_F and IOAPIC Clock Outputs

The PCIF clock outputs are intended to be used, if required, for systems IOAPIC clock functionality. ANY two of the PCI_F clock outputs can be used as IOAPIC 33-MHz clock outputs. They are 3.3V outputs will be divided down via a simple resistive voltage divider to meet specific system IOAPIC clock voltage requirements. In the event these clocks are not required, then these clocks can be used as general PCI clocks or disabled via the assertion of the PCI_STP# pin.

Note:

3. 0 = 10K Pull-down resistor, 1 = 10k Pull-up resistor.

3V66_1/VCH Clock Output

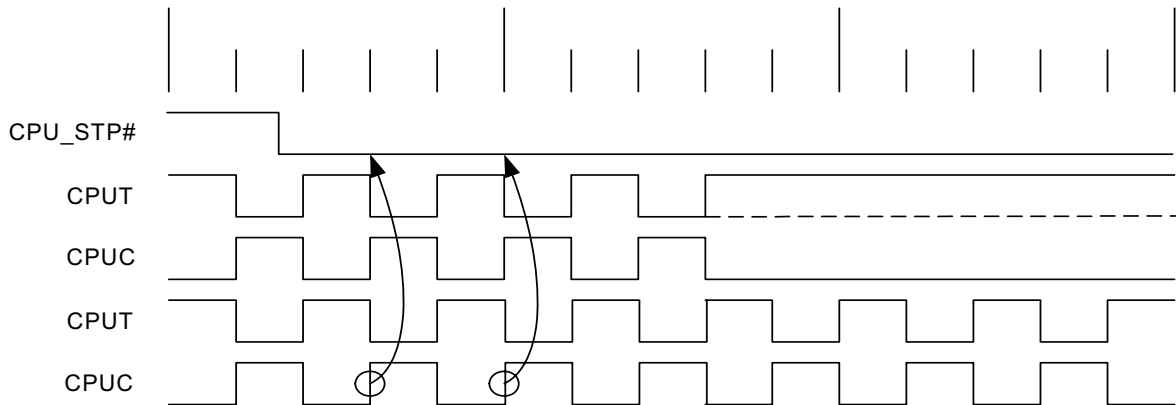
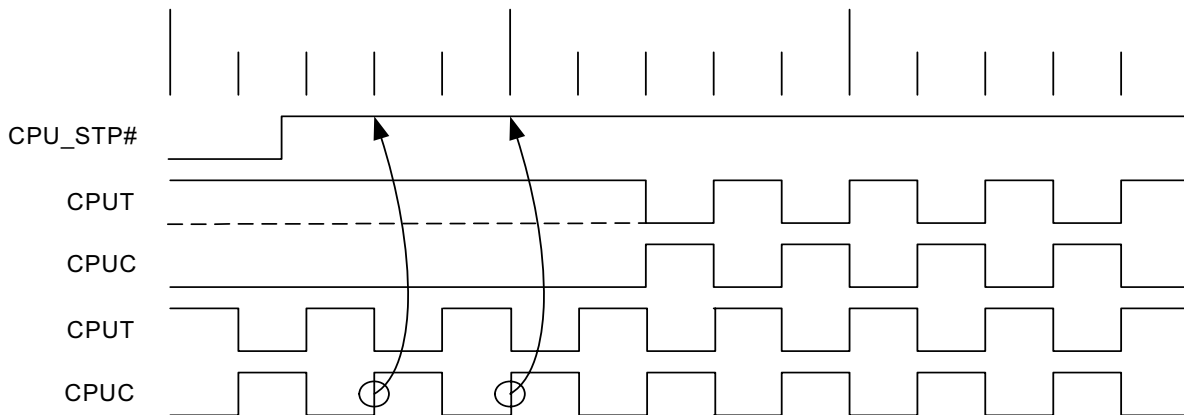
The 3V66_1/VCH pin has a dual functionality that is selectable via SMBus. If Byte0, Bit 5 = '1', then the output is configured as a 48-MHz non-spread spectrum output. This output is phase aligned with the other 48M outputs (USB and DOT), to within 1 ns pin-to-pin skew. The switching of 3V66_1/VCH into VCH mode occurs at system power on. When the SMBus Bit 5 of Byte 0 is programmed from a '0' to a '1', the 3V66_1/VCH output may glitch while transitioning to 48M output mode.

CPU_STP# Clarification

The CPU_STP# signal is an active LOW input used for synchronous stopping and starting the CPU output clocks while the rest of the clock generator continues to function.

CPU_STP# – Assertion

When CPU_STP# pin is asserted, all CPUT/C outputs that are set with the SMBus configuration to be stoppable via assertion of CPU_STP# will be stopped after being sampled by two falling CPUT/C clock edges. The final state of the stopped CPU signals is CPUT = HIGH and CPU0C = LOW. There is no change to the output drive current values during the stopped state. The CPUT is driven HIGH with a current value equal to (Mult 0 'select') x (Iref), and the CPUC signal will not be driven. Due to external pull-down circuitry CPUC will be LOW during this stopped state.


Figure 3. CPU_STP# Assertion Waveform

Figure 4. CPU_STP# Deassertion Waveform
CPU_STP# Deassertion

The deassertion of the CPU_STP# signal will cause all CPUT/C outputs that were stopped to resume normal operation in a synchronous manner. Synchronous manner meaning that no short or stretched clock pulses will be produced when the clock resumes. The maximum latency from the deassertion to active outputs is no more than 2 CPUC clock cycles.

Three-state Control of CPU Clocks Clarification

During CPU_STP# and PD# modes, CPU clock outputs may be set to driven or undriven (three-state) by setting the corresponding SMBus entry in Bit6 of Byte0 and Bit6 of Byte1.

Table 9. Cypress Clock Power Management Truth Table

B0b6	B1b6	PD#	CPU_STP#	Stoppable CPUT	Stoppable CPUC	Non-Stop CPUT	Non-Stop CPUC
0	0	1	1	Running	Running	Running	Running
0	0	1	0	Iref x6	Iref x6	Running	Running
0	0	0	1	Iref x2	Low	Iref x2	Low
0	0	0	0	Iref x2	Low	Iref x2	Low
0	1	1	1	Running	Running	Running	Running
0	1	1	0	Hi Z	Hi Z	Running	Running
0	1	0	1	Hi Z	Hi Z	Hi Z	Hi Z
0	1	0	0	Hi Z	Hi Z	Hi Z	Hi Z
1	0	1	1	Running	Running	Running	Running
1	0	1	0	Iref x6	Iref x6	Running	Running
1	0	0	1	Hi Z	Hi Z	Hi Z	Hi Z
1	0	0	0	Hi Z	Hi Z	Hi Z	Hi Z

Table 9. Cypress Clock Power Management Truth Table (continued)

B0b6	B1b6	PD#	CPU_STP#	Stoppable CPUT	Stoppable CPUC	Non-Stop CPUT	Non-Stop CPUC
1	1	1	1	Running	Running	Running	Running
1	1	1	0	Hi Z	Hi Z	Running	Running
1	1	0	1	Hi Z	Hi Z	Hi Z	Hi Z
1	1	0	0	Hi Z	Hi Z	Hi Z	Hi Z

PCI_STP# Assertion

The PCI_STP# signal is an active LOW input used for synchronous stopping and starting the PCI outputs while the rest of the clock generator continues to function. The set-up time for capturing PCI_STP# going LOW is 10 ns (t_{setup}) (see Figure 7). The PCI_F clocks will not be affected by this pin if their control bits in the SMBus register are set to allow them to be free running.

PCI_STP# – Deassertion

The deassertion of the PCI_STP# signal will cause all PCI and stoppable PCI_F clocks to resume running in a synchronous manner within two PCI clock periods after PCI_STP# transitions to a high level.

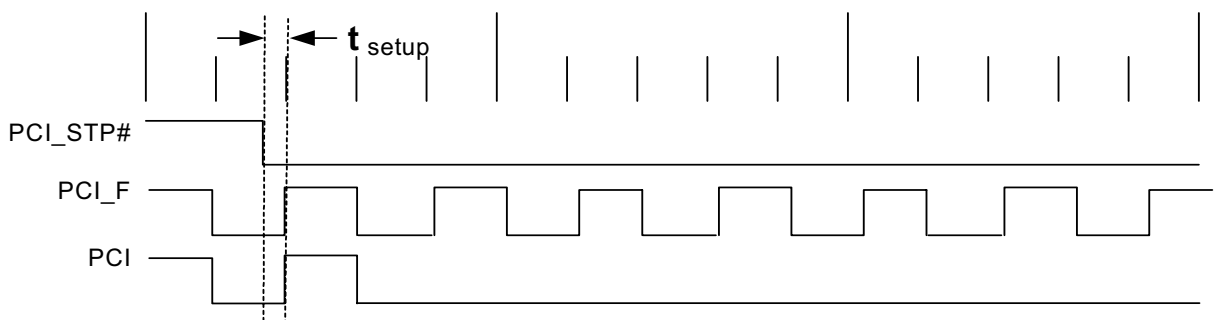
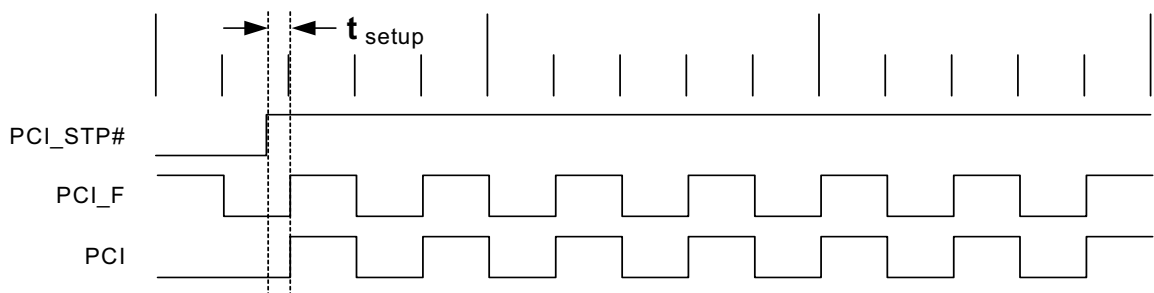
Note that the PCI STOP function is controlled by two inputs. One is the device PCI_STP# pin number 34 and the other is SMBus byte 0 bit 3. These two inputs to the function are logically ANDed. If either the external pin or the internal SMBus register bit is set low then the stoppable PCI clocks will be stopped in a logic low state. Reading SMBus Byte 0 Bit 3 will return a 0 value if either of these control bits are set LOW thereby indicating the devices stoppable PCI clocks are not running.

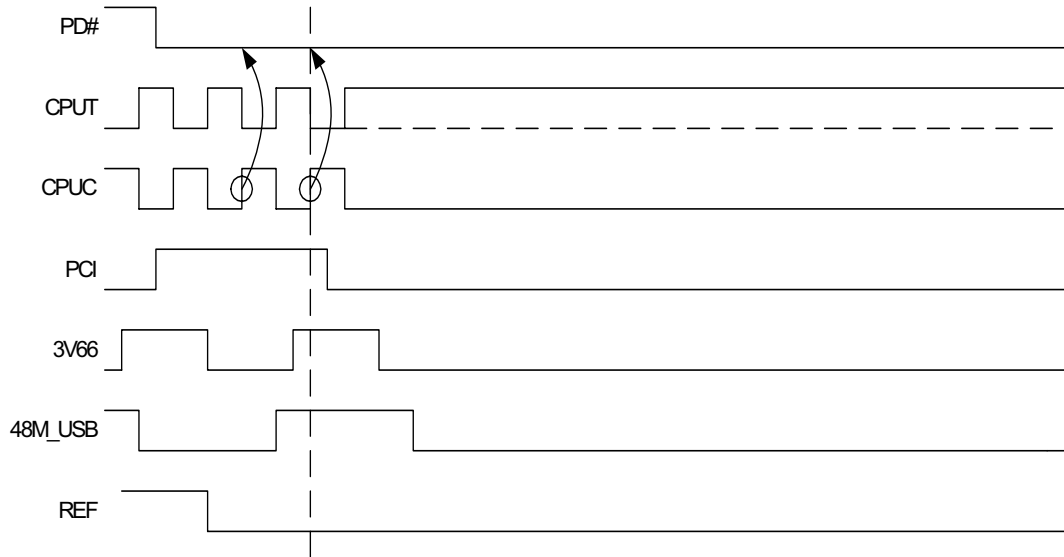
PD# (Power-down) Clarification

The PD# (Power-down) pin is used to shut off ALL clocks prior to shutting off power to the device. PD# is an asynchronous active LOW input. This signal is synchronized internally to the device powering down the clock synthesizer. PD# is an asynchronous function for powering up the system. When PD# is low, all clocks are driven to a LOW value and held there and the VCO and PLLs are also powered down. All clocks are shut down in a synchronous manner so has not to cause glitches while transitioning to the low 'stopped' state.

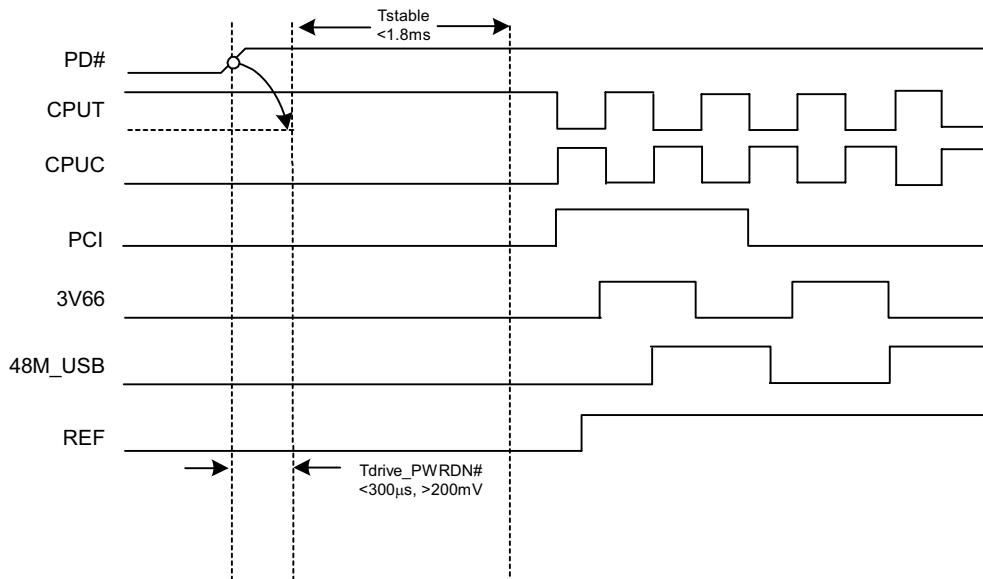
PD# – Assertion

When PD# is sampled LOW by two consecutive rising edges of the CPUC clock, then on the next HIGH-to-LOW transition of PCIF, the PCIF clock is stopped LOW. On the next HIGH-to-LOW transition of 66Buff, the 66Buff clock is stopped LOW. From this time, each clock will stop LOW on its next HIGH-to-LOW transition, except the CPUC clock. The CPU clocks are held with the CPUC clock pin driven HIGH with a value of $2 \times I_{ref}$, and CPUC undriven. After the last clock has stopped, the rest of the generator will be shut down.

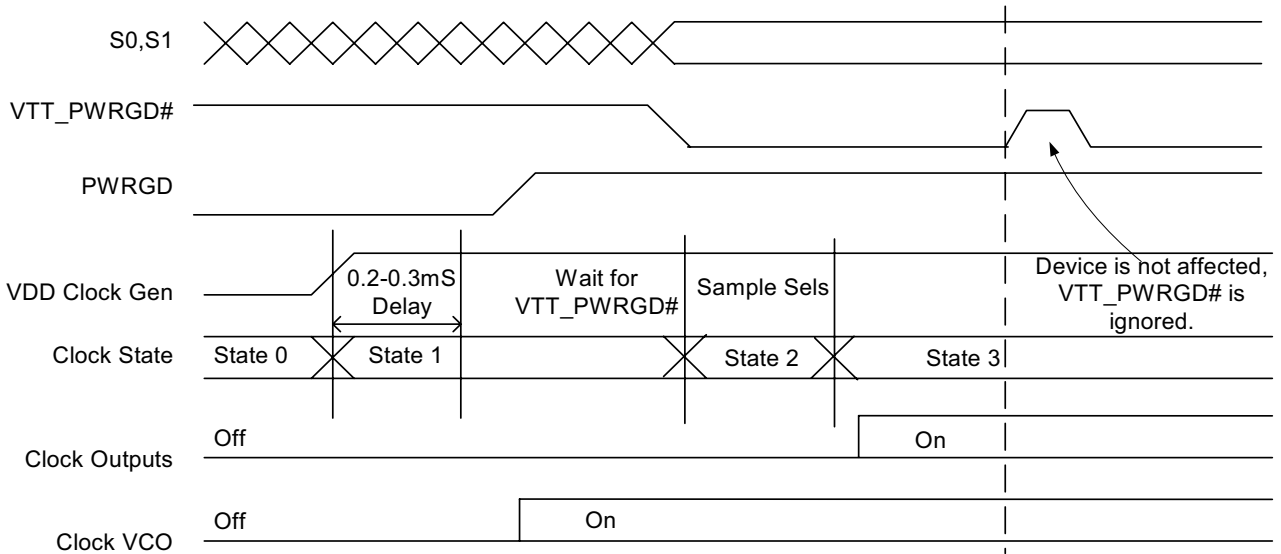
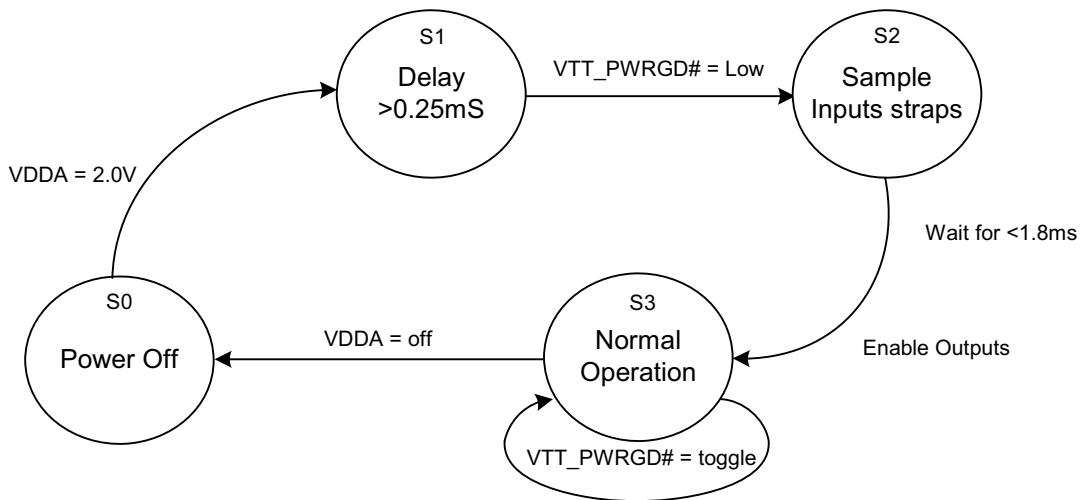

Figure 5. PCI_STP# Assertion Waveform

Figure 6. PCI_STP# Deassertion Waveform


Figure 7. Power-down Assertion Timing Waveforms
PD# – Deassertion

The power-up latency between PD# rising to a valid logic '1' level and the starting of all clocks is less than 1.8 ms.


Figure 8. Power-down Assertion Timing Waveforms
Table 10. PD# Functionality

PD#	3V66	PCI_F	PCI	USB/DOT
1	66 MHz	33 MHz	33 MHz	48 MHz
0	Low	Low	Low	Low


Figure 9. VTT_PWRGD# Timing Diagram

Figure 10. Clock Generator Power-up/Run State Diagram

Absolute Maximum Conditions

Parameter	Description	Condition	Min.	Max.	Unit
V _{DD}	Core Supply Voltage		-0.5	4.6	V
V _{DD_A}	Analog Supply Voltage		-0.5	4.6	V
V _{IN}	Input Voltage	Relative to V _{SS}	-0.5	V _{DD} +0.5	VDC
T _S	Temperature, Storage	Non-functional	-65	150	°C
T _A	Temperature, Operating Ambient	Functional	0	70	°C
T _J	Temperature, Junction	Functional	-	150	°C
ESD _{HBM}	ESD Protection (Human Body Model)	MIL-STD-883, Method 3015	2000	-	V
∅ _{JC}	Dissipation, Junction to Case	Mil-STD-883E Method 1012.1	20.62		°C/W
∅ _{JA}	Dissipation, Junction to Ambient	JEDEC (JESD 51)	62.26		°C/W
UL-94	Flammability Rating	@1/8 in.	V-0		
MSL	Moisture Sensitivity Level		1		

DC Electrical Specifications

Parameter	Description	Conditions	Min.	Max.	Unit
V _{DD} , V _{DDA}	3.3 Operating Voltage	3.3V ± 5%	3.135	3.465	V
V _{IL12C}	Input Low Voltage	SDATA, SCLK	-	-	1.0
V _{IH12C}	Input High Voltage	SDATA, SCLK	2.2	-	-
V _{IL}	Input Low Voltage		V _{SS} - 0.5	0.8	V
V _{IH}	Input High Voltage		2.0	V _{DD} + 0.5	V
V _{ILS2}	S2 Input Low Voltage	V _{DD} = 3.3V	V _{SS} - 0.5	0.7	V
V _{IMS2}	S2 Input Mid Voltage	V _{DD} = 3.3V	1.2	1.6	V
V _{IHS2}	S2 Input High Voltage	V _{DD} = 3.3V	2.0	V _{DD} + 0.5	V
I _{IL}	Input Leakage Current	except Pull-ups or Pull downs 0 < V _{IN} < V _{DD}	-5	5	μA
V _{OL}	Output Low Voltage	I _{OL} = 1 mA	-	0.4	V
V _{OH}	Output High Voltage	I _{OH} = -1 mA	2.4	-	V
I _{OZ}	High-Impedance Output Current		-10	10	μA
C _{IN}	Input Pin Capacitance		2	5	pF
C _{OUT}	Output Pin Capacitance		3	6	pF
L _{IN}	Pin Inductance		-	7	nH
V _{XIH}	Xin High Voltage		0.7V _{DD}	V _{DD}	V
V _{XIL}	Xin Low Voltage		0	0.3V _{DD}	V
I _{DD}	Dynamic Supply Current	At 166 MHz and all outputs loaded per <i>Table 11</i> and <i>Figures 11</i> and <i>12</i>	-	280	mA
I _{PD}	Power-down Supply Current	PD# Asserted, Byte0 bit 6="1"	-	2.0	mA

AC Electrical Specifications

Parameter	Description	Condition	Min.	Max.	Unit
Crystal					
T _{DC}	XIN Duty Cycle	When driven from external source	47.5	52.5	%
T _{PERIOD}	XIN period	Measured at VDD/2	69.841	71.0	ns
T _R / T _F	XIN Rise and Fall Times	Measured between 0.3VDD and 0.7VDD	-	10.0	ns
T _{CCJ}	XIN Cycle to Cycle Jitter	When driven from external source	-	500	ps

AC Electrical Specifications (continued)

Parameter	Description	Condition	Min.	Max.	Unit
CPU at 0.7V					
T _{DC}	CPUT and CPUC Duty Cycle	Measured at VOX	45	55	%
T _{PERIOD}	100MHz CPUT and CPUC Period	Measured at VOX	5.9	6.1	ns
T _{PERIOD}	133 MHz CPUT and CPUC Period	Measured at VOX	9.85	10.2	ns
T _{PERIOD}	166 MHz CPUT and CPUC Period	Measured at VOX	7.35	7.65	ns
T _{SKEW}	Any CPUT/C to CPUT/C Clock Skew	See Figure 12	–	100	ps
T _{CCJ}	CPUT/C Cycle to Cycle Jitter	See Figure 12	–	255	ps
T _R / T _F	CPUT and CPUC Rise and Fall Times	Measured from 0.175 to 0.525	175	1000	ps
T _{RFM}	Rise/Fall Matching	Fraction of $2x(T_R - T_F)/(T_R + T_F)$	–	20	%
ΔT _R	Rise Time Variation	Measured from 0.175 to 0.525	–	150	ps
ΔT _F	Fall Time Variation	Measured from 0.525 to 0.175	–	150	ps
V _{OX}	Crossing Point Voltage at 0.7V Swing	See Figure 12	280	430	mv
CPU at 1.0V					
T _{DC}	CPUT and CPUC Duty Cycle	Measured at VOX	45	55	%
T _{PERIOD}	100MHz CPUT and CPUC Period	Measured at VOX	5.9	6.1	ns
T _{PERIOD}	133 MHz CPUT and CPUC Period	Measured at VOX	9.85	10.2	ns
T _{PERIOD}	166 MHz CPUT and CPUC Period	Measured at VOX	7.35	7.65	ns
T _{SKEW}	Any CPUT/C to CPUT/C Clock Skew	See Figure 11	–	100	ps
T _{CCJ}	CPUT/C Cycle to Cycle Jitter	See Figure 11	–	255	ps
T _R / T _F	CPUT and CPUC Rise and Fall Times	Measured differentially from –0.35 to 0.35	175	1000	ps
V _{OX}	Crossing Point Voltage at 0.7V Swing	See Figure 11	510	760	mv
Δ Slew	Absolute Single Ended Rise/Fall Waveform Symmetry	Measured from 0.41 to 0.36	–	325	ps
3V66					
T _{DC}	3V66 Duty Cycle	Measured at 1.5V	45	55	%
T _{PERIOD}	3V66 Period	Measured at 1.5V	15.0	15.3	ns
T _{HIGH}	3V66 High Time	Measured at 2.4V	4.95	–	ns
T _{LOW}	3V66 Low Time	Measured at 0.4V	4.55	–	ns
T _R / T _F	3V66 Rise and Fall Times	Measured from 0.4V to 2.4V	0.5	2.3	ns
T _{SKEW}	Any 3V66 to Any 3V66 Clock Skew	Measured at 1.5V	–	500	ps
T _{CCJ}	3V66 Cycle to Cycle Jitter	Measured at 1.5V. See Table 11	–	400	ps
PCI/PCIF					
T _{DC}	PCI /PCI_F Duty Cycle	Measure at 1.5V	45	55	%
T _{PERIOD}	PCIF/PCI Period	Measured at 1.5V		30	ns
T _{HIGH}	PCIF and PCI high time	Measured at 1.5V	12.0	–	ns
T _{LOW}	PCIF and PCI low time	Measured at 0.4V	12.0	–	ns
T _R / T _F	PCIF and PCI rise and fall times	Measured at 0.4V to 2.4V	0.5	2.3	ns
T _{SKEW}	Any PCI clock to Any PCI clock Skew	Measured at 1.5V	–	500	ps
T _{CCJ}	PCIF and PCI Cycle to Cycle Jitter	Measured at 1.5V. See Table 11	–	325	ps
48M_DOT					
T _{DC}	Duty Cycle	Measured at 1.5V	45	55	%
T _{PERIOD}	Period	Measured at 1.5V	20.837		ns
T _R / T _F	Rise and Fall Times	Measured at 0.4 to 2.4V	0.5	1.0	ns
T _{CCJ}	REF Cycle to Cycle Jitter	Measured at 1.5V. See Table 11	–	350	ps

AC Electrical Specifications (continued)

Parameter	Description	Condition	Min.	Max.	Unit
48M_USB					
T _{DC}	Duty Cycle	Measured at 1.5V	45	55	%
T _{PERIOD}	Period	Measured at 1.5V	20.8299	20.8333	ns
T _R / T _F	Rise and Fall Times	Measured at 0.4 to 2.4V	1.0	2.0	ns
T _{CCJ}	Cycle to Cycle Jitter	Measured at 1.5V. See <i>Table 11</i>	–	350	ps
REF					
T _{DC}	REF Duty Cycle	Measured at 1.5V	45	55	%
T _{PERIOD}	REF Period	Measured at 1.5V	69.84	71.0	ns
T _R / T _F	REF Rise and Fall Times	Measured at 0.4 to 2.4V	0.5	2.0	V/ns
T _{CCJ}	REF Cycle to Cycle Jitter	Measured at 1.5V. See <i>Table 11</i>	–	1000	ps
ENABLE/DISABLE and SETUP					
T _{PZL} /T _{PZH}	Output Enable Delay (all outputs)		1.0	10.0	ns
T _{PLZ} /T _{PHZ}	Output Disable Delay (all outputs)		1.0	10.0	ns
T _{STABLE}	Clock Stabilization from Power-up		–	3.0	ms
T _{SS}	Stopclock Setup Time		10.0	–	ns
T _{SH}	Stopclock Hold Time		0	–	ns

Table 11. Maximum Lumped Capacitive Output Loads

Clock	Max Load	Unit
PCI Clocks	30	pF
3V66	30	pF
48M_USB Clock	20	pF
48M_DOT	10	pF
REF Clock	50	pF

Test and Measurement Set-up
For Differential CPU Output Signals

The following diagram shows lumped test load configurations for the differential Host Clock Outputs.

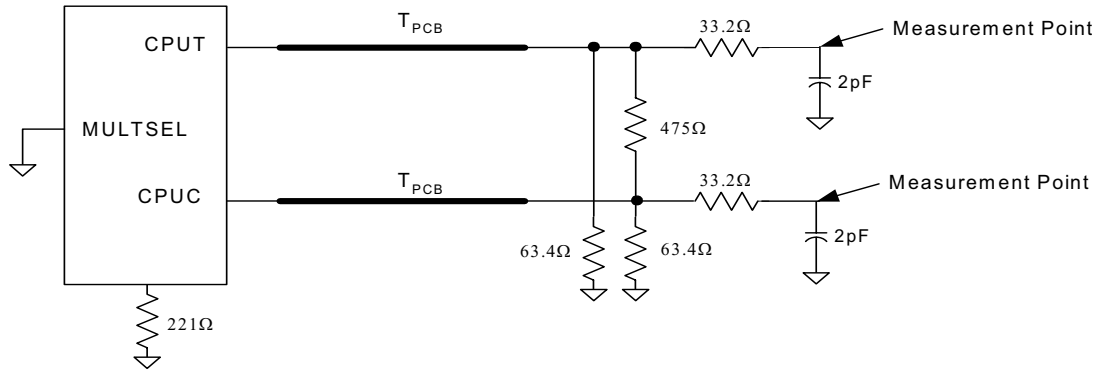


Figure 11. 1.0V Test Load Termination

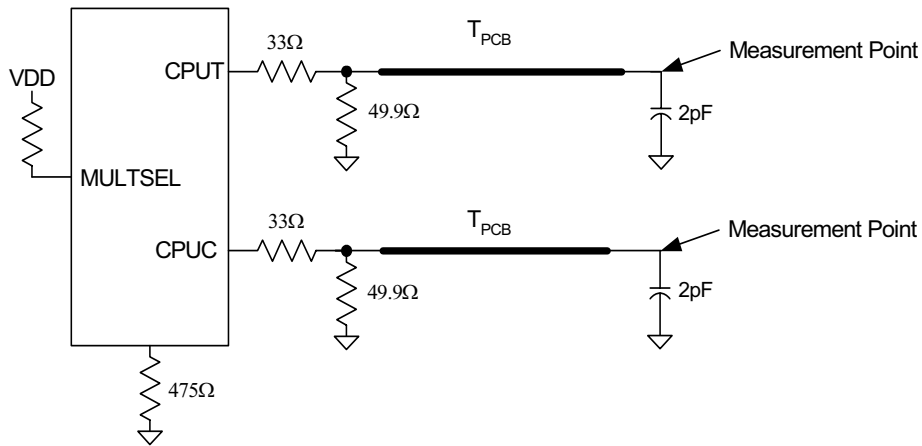
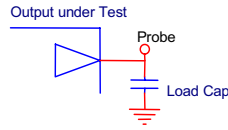
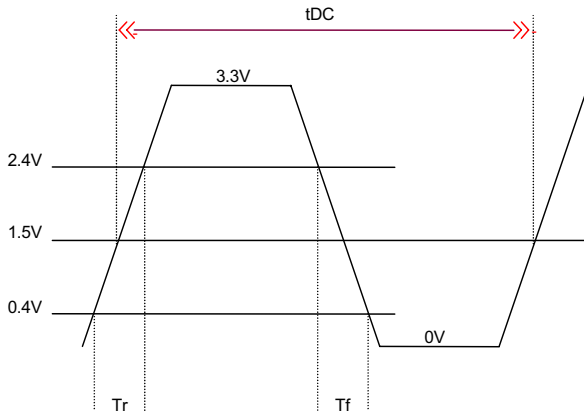


Figure 12. 0.7V Test Load Termination

For Single-Ended Output Signals

3.3V signals

Figure 13.
Buffer Characteristics
Current Mode CPU Clock Buffer Characteristics

The current mode output buffer detail and current reference circuit details are contained in the previous table of this data sheet. The following parameters are used to specify output buffer characteristics:

1. Output impedance of the current mode buffer circuit – R_o (see *Figure 14*).
2. Minimum and maximum required voltage operation range of the circuit – V_{op} (see *Figure 14*).
3. Series resistance in the buffer circuit – R_{os} (see *Figure 14*).
4. Current accuracy at given configuration into nominal test load for given configuration.

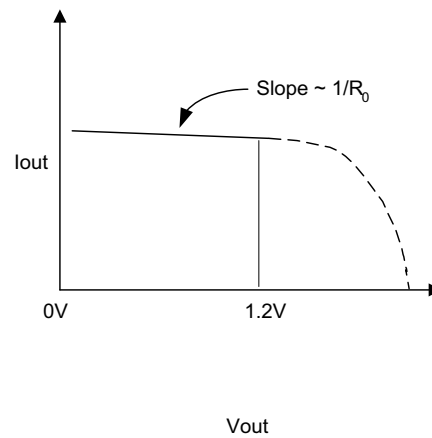
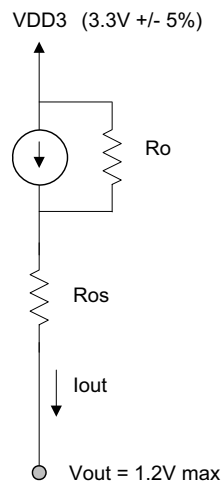

Figure 14.

Table 12. Host Clock (HCSL) Buffer Characteristics

Characteristic	Minimum	Maximum
Ro	3000 Ohms (recommended)	N/A
Ros		
Vout	N/A	1.2V

Iout is selectable depending on implementation. The parameters above apply to all configurations. Vout is the voltage at the pin of the device.

The various output current configurations are shown in the host swing select functions table. For all configurations, the deviation from the expected output current is ±7% as shown in the current accuracy table.

Table 13. CPU Clock Current Select Function

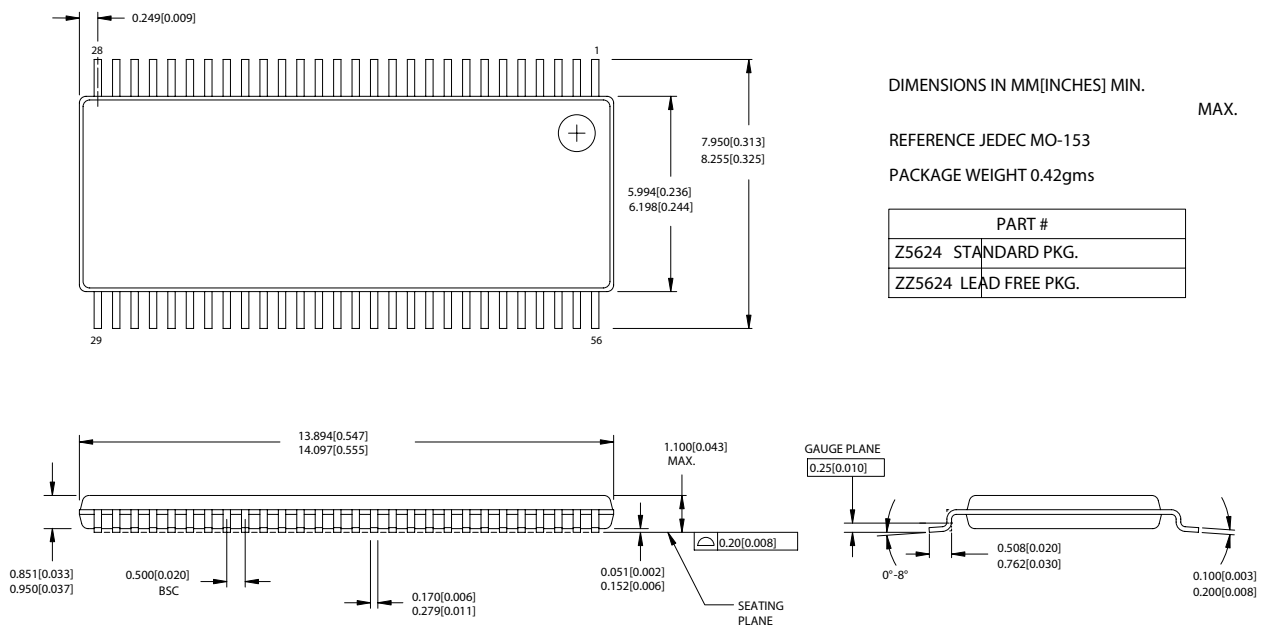
Mult0	Board Target Trace/Term Z	Reference R, Iref – Vdd (3*Rr)	Output Current	Voh @ Z
0	50 Ohms	Rr = 221 1%, Iref = 5.00mA	Ioh = 4*Iref	1.0V @ 50
1	50 Ohms	Rr = 475 1%, Iref = 2.32mA	Ioh = 6*Iref	0.7V @ 50

Ordering Information

Part Number	Package Type	Product Flow
CY28408ZC	56-Pin TSSOP	Commercial, 0° to 70°C
CY28408ZCT	56-Pin TSSOP - Tape and Reel	Commercial, 0° to 70°C

Package Drawings and Dimensions

56-Lead Thin Shrunken Small Outline Package, Type II (6 mm x 12 mm) Z56



While SLI has reviewed all information herein for accuracy and reliability, Spectra Linear Inc. assumes no responsibility for the use of any circuitry or for the infringement of any patents or other rights of third parties which would result from each use. This product is intended for use in normal commercial applications and is not warranted nor is it intended for use in life support, critical medical instruments, or any other application requiring extended temperature range, high reliability, or any other extraordinary environmental requirements unless pursuant to additional processing by Spectra Linear Inc., and expressed written agreement by Spectra Linear Inc. Spectra Linear Inc. reserves the right to change any circuitry or specification without notice.