

GLASS PASSIVATED BRIDGE RECTIFIERS

REVERSE VOLTAGE - 50 to 1000Volts
FORWARD CURRENT - 1.0 Amperes

FEATURES

- Rating to 1000V PRV
- Ideal for printed circuit board
- Low forward voltage drop, high current capability
- Reliable low cost construction utilizing molded plastic technique results in inexpensive product
- Lead tin Pb/Sn copper
- The plastic material has UL flammability classification 94V-0

MECHANICAL DATA

- Polarity: As marked on Body
- Weight: 0.02 ounces, 0.38 grams
- mounting position: Any

DF

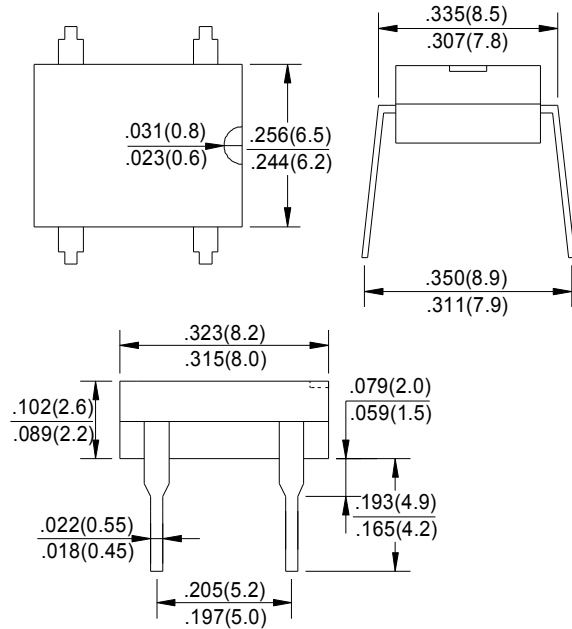

Dimensions in inches and (millimeters)

MAXIMUM RATINGS AND ELECTRICAL CHARACTERISTICS

Rating at 25°C ambient temperature unless otherwise specified.

Single phase, half wave, 60Hz, resistive or inductive load.

For capacitive load, derate current by 20%

CHARACTERISTICS	SYMBOL	DF005	DF01	DF02	DF04	DF06	DF08	DF10	UNIT
Maximum Recurrent Peak Reverse Voltage	V _{RRM}	50	100	200	400	600	800	1000	V
Maximum RMS Voltage	V _{RMS}	35	70	140	280	420	560	700	V
Maximum DC Blocking Voltage	V _{DC}	50	100	200	400	600	800	1000	V
Maximum Average Forward Rectified Current @T _A =40°C	I <sub(av)< sub=""></sub(av)<>	1.0							A
Peak Forward Surge Current 8.3ms Single Half Sine-Wave Super Imposed on Rated Load	I _{FSM}	50							A
Maximum Forward Voltage at 1.0A DC	V _F	1.1							V
Maximum DC Reverse Current at Rated DC Blocking Voltage @T _J =25°C @T _J =125°C	I _R	10 500							μA
I ² Rating for Fusing (t<8.3ms)	I ² t	10.4							A ² s
Typical Junction Capacitance Per Element (Note1)	C _J	25							pF
Typical Thermal Resistance (Note2)	R _{θJC}	40							°C/W
Operating Temperature Range	T _J	-55 to +150							°C
Storage Temperature Range	T _{STG}	-55 to +150							°C

Note:1. Measured at 1.0MHz and applied reverse voltage of 4.0V DC

2. Thermal resistance from junction to ambient mounted on P.C.B
with 0.5*0.5"(13*13mm) copper pads.



FIG.1-FORWARD CURRENT DERATING CURVE

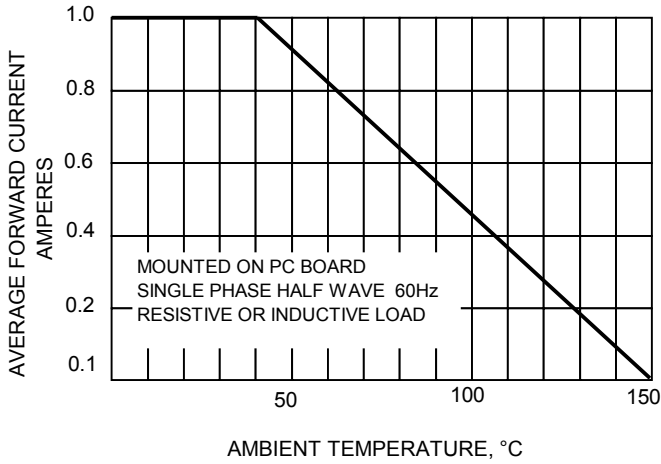

FIG.2-MXIMUM NON-REPETITIVE SURGE CURRENT

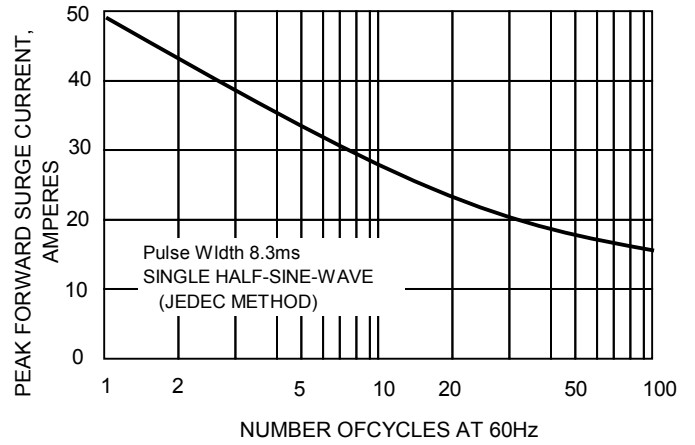

FIG.3-TYPICAL JUNCTION CAPACITANCE

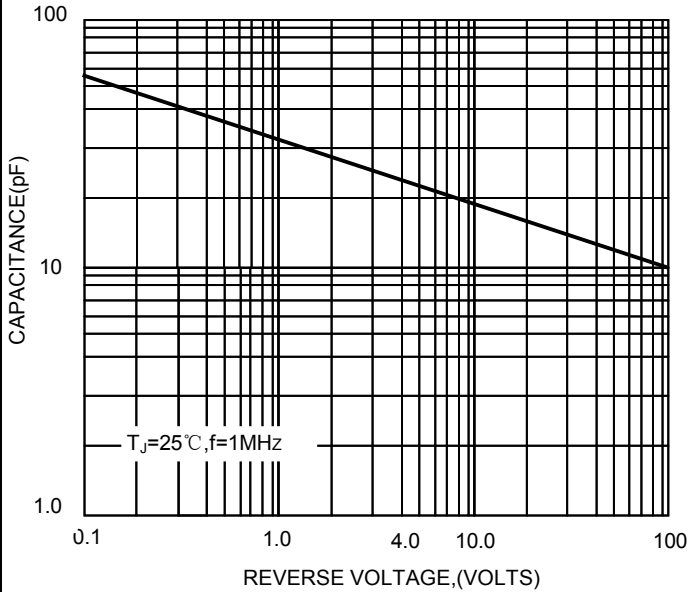

FIG.4-TYPICAL FORWARD CHARACTERISTICS

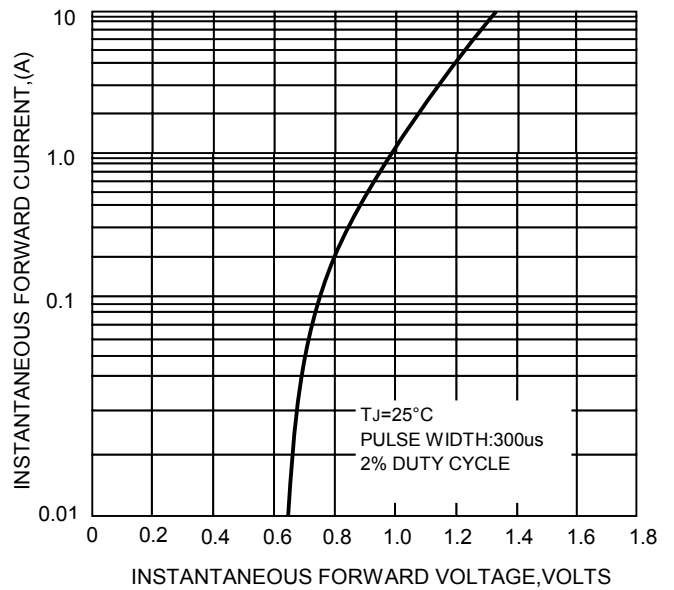

FIG.5-TYPICAL REVERSE CHARACTERISTICS

