

OV7680 VGA product brief

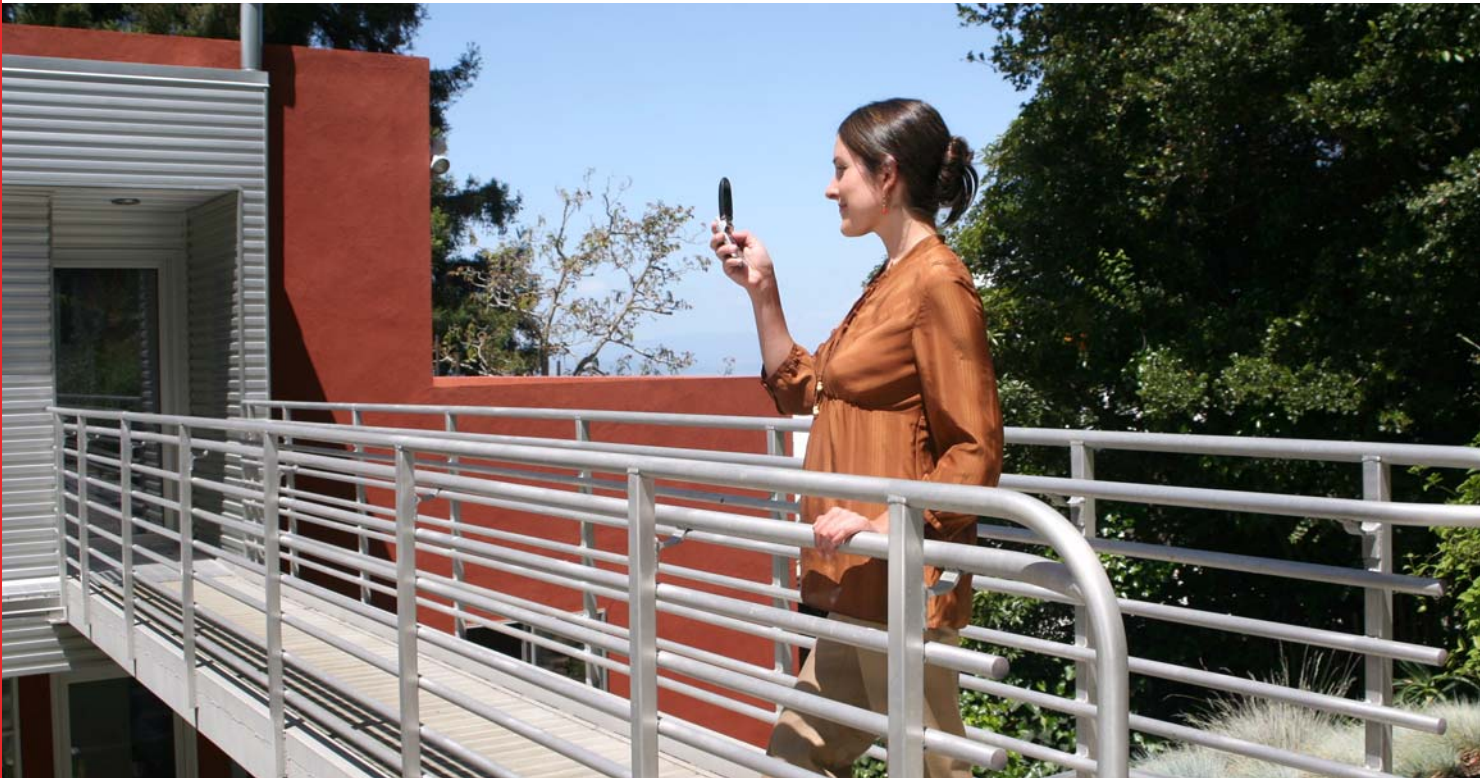

available in
a lead-free
package

1/10 inch VGA image sensor for low cost, ultra-slim camera phones

The OV7680 is a single-chip, high-performance VGA image sensor with an optical format of 1/10 inch. Using a $2.2\ \mu\text{m} \times 2.2\ \mu\text{m}$ pixel built on OmniPixel2™ technology, the OV7680 enables ultra thin camera modules of just $4.5 \times 4.5 \times 3.17\ \text{mm}$. This is a critical characteristic for slim camera phones and notebook applications where the camera module can be no thicker than the LCD housing.

The OV7680's ultra thin module size allows for a 1-plastic lens design. Additionally, the OV7680's unique non-linear micro lens shift technology allows for a reduction in the distance between sensor and lens; reducing module height even further without loss of image quality or camera performance.

The OV7680 employs OmniVision's proprietary OmniPixel2 architecture, which significantly increases signal-to-noise ratio and delivers exceptional low-light performance. Operating at a low voltage, the OV7680 image sensor provides the full functionality of a single chip VGA camera and image processor in a small footprint package. This includes full-frame, sub-sampled or windowed 8-bit images in a wide range of formats controlled through a serial camera control bus (SCCB) interface.

The OV7680 can operate at 30 frames per second (fps) in VGA with full user control over image quality, formatting and output data transfer. As part of OmniVision's next generation of image sensors, the OV7680 delivers low-noise, low-cost, low-power consumption, high integration, wide dynamic range and excellent low-light performance.

applications

- camera/video phones
- webcams
- games/toys
- pattern/face recognition

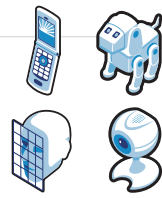

OV7680

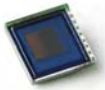

ordering information

- OV07680-G00A (color, chip probing, no backgrinding)
- OV07680-V24A (color, lead-free, CSP2-24)
- OV07680-G03A (reconstructed wafer)

product features

- high sensitivity for low-light operation
- low operating voltage for embedded portable applications
- lens shading correction
- saturation level auto adjust
- edge enhancement and auto adjust
- ISP includes noise reduction and defect pixel correction
- image quality controls including color saturation, hue, gamma, sharpness (edge enhancement) and anti-blooming
- automatic image control functions including:
 - automatic exposure control (AEC)
 - automatic gain control (AGC)
 - automatic white balance (AWB)
 - automatic band filter (ABF)
 - automatic black-level calibration (ABLC)
 - 50/60 Hz auto detection

product specifications

- array size: 640 x 480
- power supply:
 - analog: 2.45V to 3.0V
 - I/O: 1.7V to 3.0V
- package dimensions: 3285 μm x 3485 μm
- maximum image transfer rate:
 - 30 fps for VGA
 - 60 fps for QVGA
- S/N ratio: 40 dB
- chief ray angle: 29° non-linear
- power requirements:
 - active: 80mW typical
 - standby: < 20 μA
- lens size: 1/10"
- pixel size: 2.2 μm x 2.2 μm
- image area: 1443.2 μm x 1082.4 μm

functional block diagram

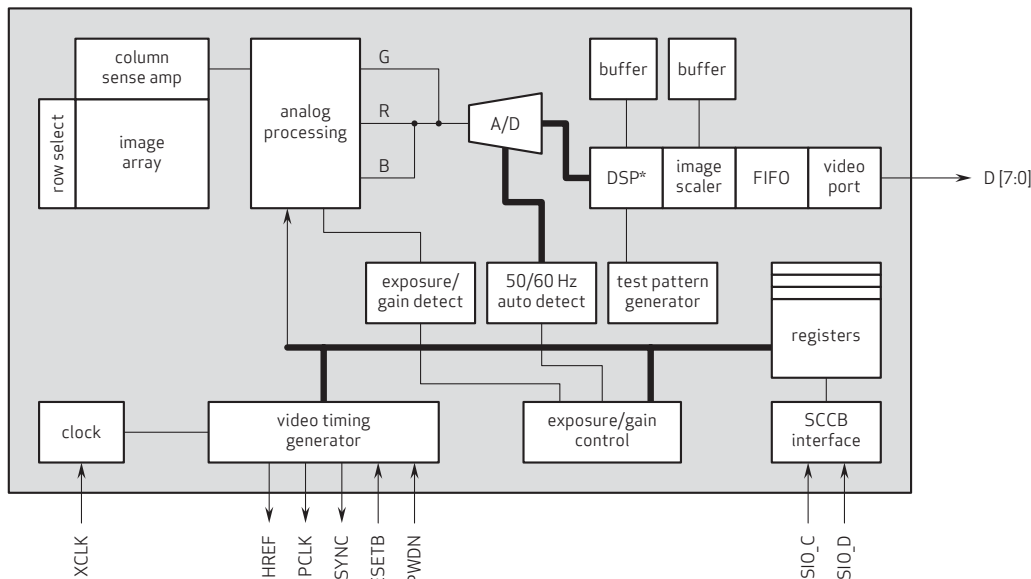

note 1 DSP* (lens shading correction, white/black pixel correction, auto white balance, etc.)

1341 Orleans Drive
Sunnyvale, CA 94089

tel: +1 408 542 3000
fax: +1 408 542 3001
www.ovt.com

OmniVision reserves the right to make changes to their products or to discontinue any product or service without further notice. OmniVision, the OmniVision logo and Omnipixel are registered trademarks of OmniVision Technologies, Inc. Omnipixel is a trademark of OmniVision Technologies, Inc. All other trademarks are the property of their respective owners.