

387-083 Composite Multi-Shield Cone and Ring Style EMI/RFI Shield Termination Backshell with Self-Locking Rotatable Coupling and Strain Relief

A

CONNECTOR DESIGNATOR:	
H	MIL-DTL-38999 Series III and IV
SELF-LOCKING	
ROTATABLE COUPLING	
STANDARD PROFILE	

Note: See Table I in Intro for Front-End Dimensional Details

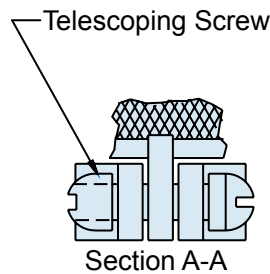
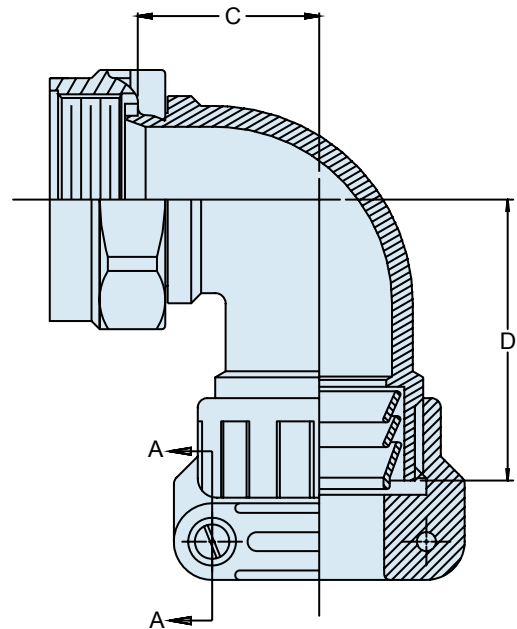
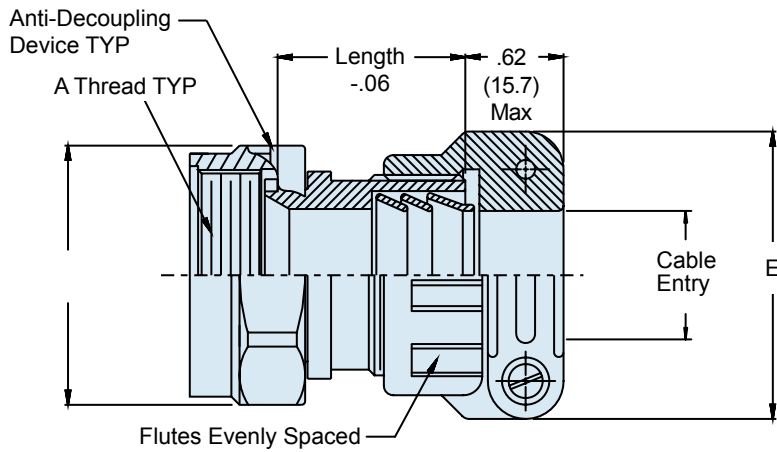
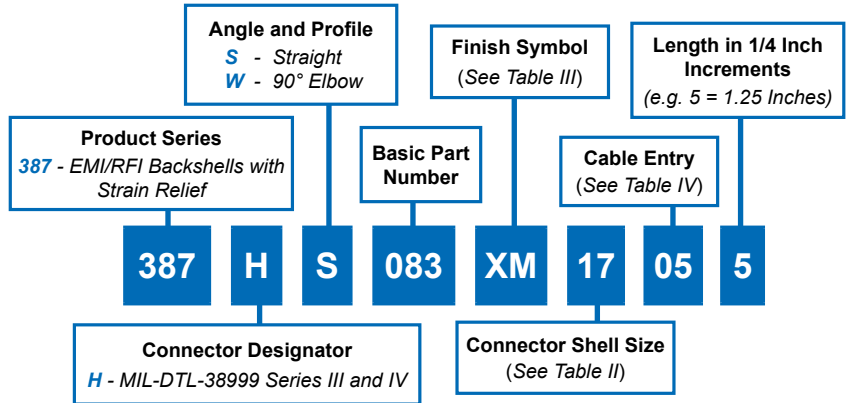

NOTES

1. See Table I in Intro for front-end dimensional details.
2. Coupling nut supplied unplated.
3. Metric dimensions (mm) are in parenthesis and are for reference only.

387-083
Composite Multi-Shield Cone and Ring Style
EMI/RFI Shield Termination Backshell
with Self-Locking Rotatable Coupling and Strain Relief



TABLE II: SHELL SIZE						
Shell Size	Shell Size Code	A Thread ISO Metric	B Max	C ±.078 (2.0)	D ±.078 (2.0)	Max Available Entry
09	A	M12x 1-6H	.94 (23.9)	.722 (18.3)	1.750 (44.4)	04
11	B	M15x 1-6H	1.06 (26.9)	.784 (19.9)	1.820 (46.2)	06
13	C	M18x 1-6H	1.17 (29.7)	.816 (20.7)	1.860 (47.2)	08
15	D	M22x 1-6H	1.29 (32.8)	.878 (22.3)	1.880 (47.8)	10
17	E	M25x 1-6H	1.42 (36.1)	.942 (23.9)	1.942 (49.3)	12
19	F	M28x 1-6H	1.54 (39.1)	1.003 (25.5)	2.000 (50.8)	14
21	G	M31x 1-6H	1.67 (42.4)	1.037 (26.3)	2.062 (52.4)	16
23	H	M34x 1-6H	2.01 (51.1)	1.116 (28.3)	2.194 (55.7)	17
25	J	M37x 1-6H	2.12 (53.8)	1.194 (30.3)	2.257 (57.3)	20

TABLE IV: CABLE ENTRY		
Dash Number	E Max	Cable Entry ±.039 (1.0)
04	1.125 (28.6)	.312 (7.9)
06	1.250 (31.8)	.437 (11.1)
08	1.312 (33.3)	.500 (12.7)
10	1.438 (36.5)	.625 (15.9)
12	1.625 (41.3)	.750 (19.1)
14	1.688 (42.9)	.874 (22.2)
16	1.750 (44.5)	.937 (23.8)
17	1.906 (48.5)	1.094 (27.8)
20	2.062 (52.4)	1.250 (31.8)

TABLE III: FINISH	
Symbol	Finish Description
XM	2000 Hour Corrosion Resistant Electroless Nickel
XMT	2000 Hour Corrosion Resistant Ni-PTFE, Nickel-Fluorocarbon Polymer. <i>1000 Hour Grey™</i>
XW	2000 Hour Corrosion Resistant Cadmium/Olive Drab over Electroless Nickel

BACKSHELL WEIGHT					
Symbol "S" Straight Weight Table			Symbol "W" 90° Weight Table		
Shell Size	Dash Number	Max Weight (KG)	Shell Size	Dash Number	Max Weight (KG)
09	04	.0296	09	04	.0326
11	06	.0327	11	06	.0360
13	08	.0370	13	08	.0420
15	10	.0430	15	10	.0480
17	12	.0500	17	12	.0550
19	12	.0560	19	12	.0610
21	16	.0640	21	16	.0690
23	16	.0700	23	16	.0750
25	20	.0750	25	20	.0800