

### ■ General Description

The AME41-ADJ is a micropower 3-terminal band-gap voltage regulator diode with a user adjustable output voltage. It operates over a 30µA to 20mA current range. Each circuit is trimmed at wafer sort to provide a ±0.50% initial tolerance. The design of the AME41-ADJ allows for a large range of load capacitances and operating currents. The low start-up current makes these parts ideal for battery applications.

AME offers this part in a TO-92 and SOP-8 packages as well as the space saving SOT-23.

### ■ Features

- Small Packages: SOT-23, TO-92, SOP-8
- Tolerates Capacitive Loads
- User Adjustable Reverse Breakdown Voltage
- Tight Voltage Tolerance ----- ±0.5%
- Wide Operating Current ----- 30µA to 20mA
- Wide Temperature Range ----- -40°C to +85°C
- Low Temperature Coefficient --100ppm/°C (max)
- Excellent Transient Response
- All AME's Lead Free Products Meet RoHS Standards

### ■ Applications

- Portable Electronics
- Power Supplies
- Computer Peripherals
- Data Acquisition Systems
- Battery Chargers
- Consumer Electronics

### ■ Functional Block Diagram

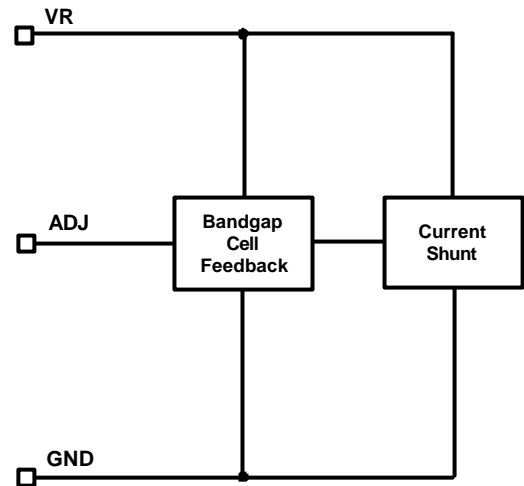

### ■ Typical Application

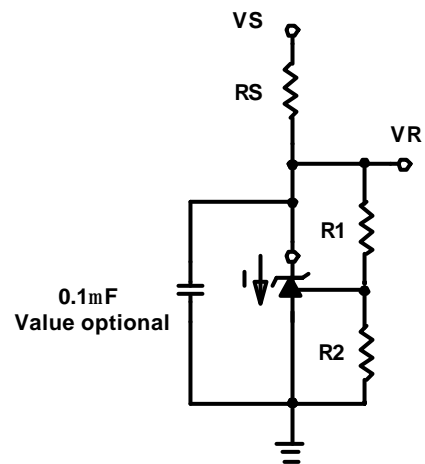

$$RS = \frac{VS - VR}{I}$$

$$VR = \frac{1.25 (R1 + R2)}{R1}$$

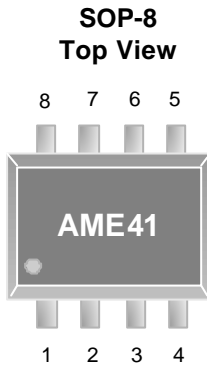
**■ Pin Configuration**

**AME 41-ADJ**

1. NC
2. NC
3. NC
4. -
5. ADJ
6. NC
7. NC
8. +

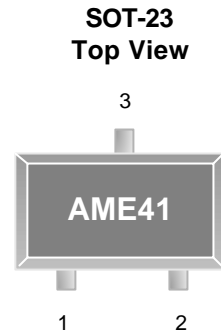
**\* Die Attach:  
Conductive Epoxy**

**AME 41-ADJ**

1. ADJ
2. +
3. -

**\* Die Attach:  
Non-Conductive Epoxy**

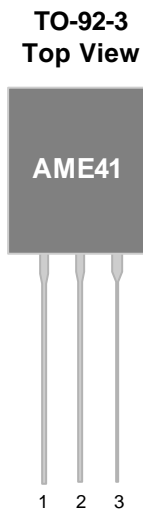
**AME 41-ADJ**

1. ADJ
2. +
3. -

**\* Die Attach:  
Non-Conductive Epoxy**

\* The NC pin must float or be connected to - (negative)



# AME41-ADJ

# Shunt Bandgap Voltage Reference

## Ordering Information

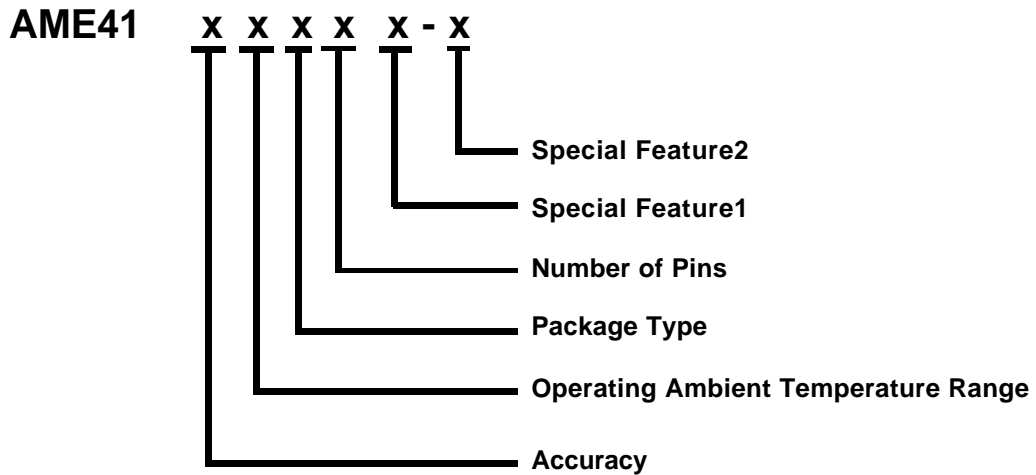

Accuracy	Operating Ambient Temperature Range	Package Type	Number of Pins	Special Feature1	Special Feature2 (For TO-92 Package Only)									
B: 0.5% (SOT-23) (SOP-8) (TO-92-3)	E: -40°C to +85°C	A: TO-92 E: SOT-2X H: SOP	A: 8 T: 3	Z: Lead Free	<table border="1"> <thead> <tr> <th></th> <th>Package</th> <th>Lead Pitch</th> </tr> </thead> <tbody> <tr> <td>N/A:</td> <td>Taping</td> <td>5.08mm</td> </tr> <tr> <td>1:</td> <td>Bulk</td> <td>2.54mm</td> </tr> </tbody> </table>		Package	Lead Pitch	N/A:	Taping	5.08mm	1:	Bulk	2.54mm
	Package	Lead Pitch												
N/A:	Taping	5.08mm												
1:	Bulk	2.54mm												



## AME41-ADJ

## Shunt Bandgap Voltage Reference

### ■ Ordering Information

Part Number	Marking*	Accuracy	Package	Operating Ambient Temperature Range
AME41BEET	ACBww	0.5%	SOT-23	- 40°C to +85°C
AME41BEETZ	ACBww	0.5%	SOT-23	- 40°C to +85°C
AME41BEAT	AME 41 BEAT yyww	0.5%	TO-92-3	- 40°C to +85°C
AME41BEAT-1	AME 41 BEAT yyww	0.5%	TO-92-3	- 40°C to +85°C
AME41BEATZ	AME 41 BEAT yyww	0.5%	TO-92-3	- 40°C to +85°C
AME41BEATZ-1	AME 41 BEAT yyww	0.5%	TO-92-3	- 40°C to +85°C
AME41BEHA	41 BEHA yyww	0.5%	SOP-8	- 40°C to +85°C
AME41BEHAZ	41 BEHA yyww	0.5%	SOP-8	- 40°C to +85°C

Note: ww & yyww represents date code

\* A line on top of the first letter represents lead free plating such as  $\overline{ACB}$ .

Please consult AME sales office or authorized Rep./Distributor for the availability of voltage accuracy and package type.

**■ Absolute Maximum Ratings**

Parameter	Maximum	Unit
Supply Current	50	mA

Caution: Stress above the listed absolute maximum rating may cause permanent damage to the device

**■ Recommended Operating Conditions**

Parameter	Symbol	Rating	Unit
Ambient Temperature Range	$T_A$	- 40 to +85	°C
Junction Temperature Range	$T_J$	- 40 to +125	°C
Storage Temperature Range	$T_{STG}$	- 65 to +150	°C
Supply Current		100 $\mu$ A ~ 20mA	

**■ Thermal Information**

Parameter	Package	Die Attach	Symbol	Maximum	Unit
Thermal Resistance* (Junction to Case)	SOT-23	Non-Conductive Epoxy	$\theta_{JC}$	140	°C / W
	TO-92-3			80	
	SOP-8	Conductive Epoxy		60	
Thermal Resistance (Junction to Ambient)	SOT-23	Non-Conductive Epoxy	$\theta_{JA}$	280	°C / W
	TO-92-3			150	
	SOP-8	Conductive Epoxy		150	
Internal Power Dissipation	SOT-23	Non-Conductive Epoxy	$P_D$	400	mW
	TO-92-3			625	
	SOP-8	Conductive Epoxy		810	
Maximum Junction Temperature				150	°C
Solder Iron (10 Sec)**				350	°C

\* Measure  $\theta_{JC}$  on center of molding compound if IC has no tab.

\*\* MIL-STD-202G 210F

**■ Electrical Specifications**

Unless otherwise specified,  $T_A = 25^\circ\text{C}$ ,  $I = 100\mu\text{A}$

Parameter	Symbol	Test Condition	Min	Typ	Max	Units
Reference Voltage, $\pm 0.5\%$	$V_{REF}$	$T_A = 25^\circ\text{C}$ , $I_{REF} = 100\mu\text{A}$	1.244	1.250	1.256	V
Minimum Current	$I_{MIN}$				30	$\mu\text{A}$
Reference Voltage Change With Current	$dV_{REF/I}$	$I_{MIN} \leq I \leq 1\text{mA}$		1.5	3	mV
		$1\text{mA} \leq I \leq 20\text{mA}$		4	8	
ADJ Pin Current	$I_{ADJ}$			20		nA
Reference Voltage Temp. Coeff.	$V_{REFTC}$	$0^\circ\text{C} < T_A < 70^\circ\text{C}$			100	ppm/°C

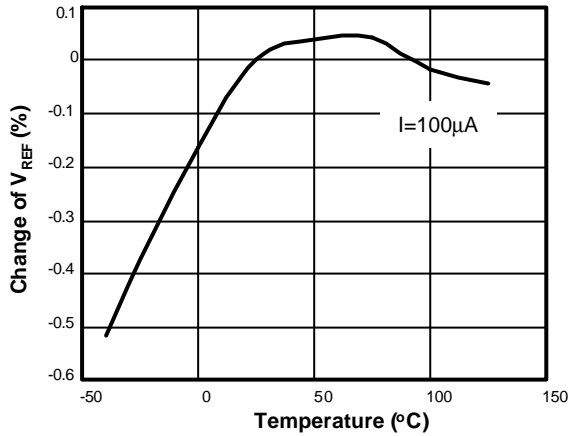
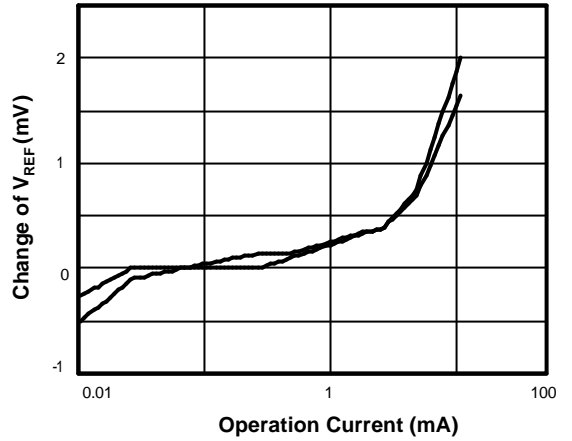
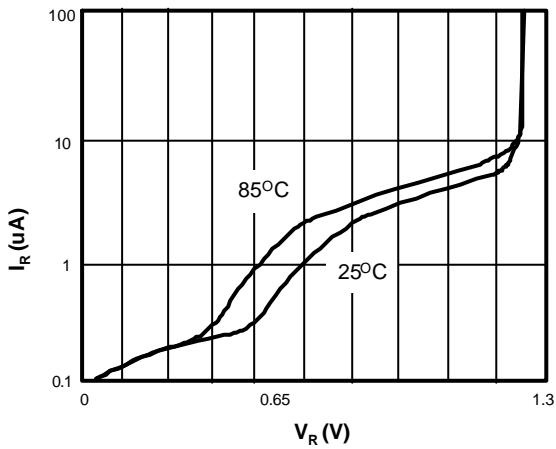
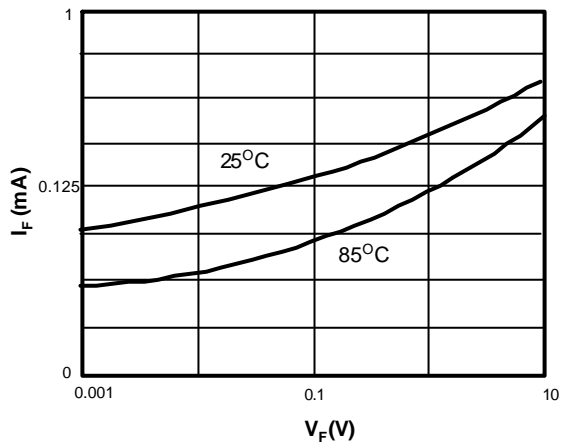
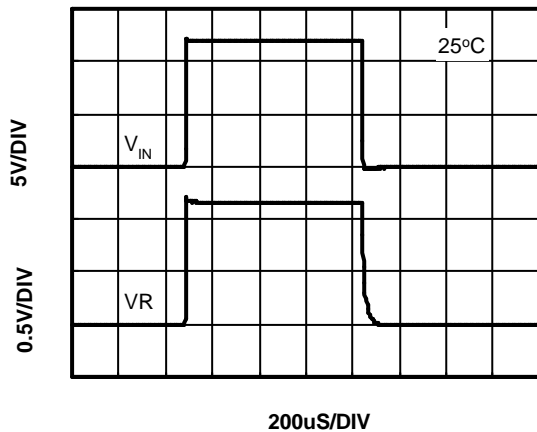
**■ Characterization Curve(For reference only)**
**Normalized Percentage Change vs. Temp.**

**Reference Voltage Change vs. Current**

**Reverse Characteristic**

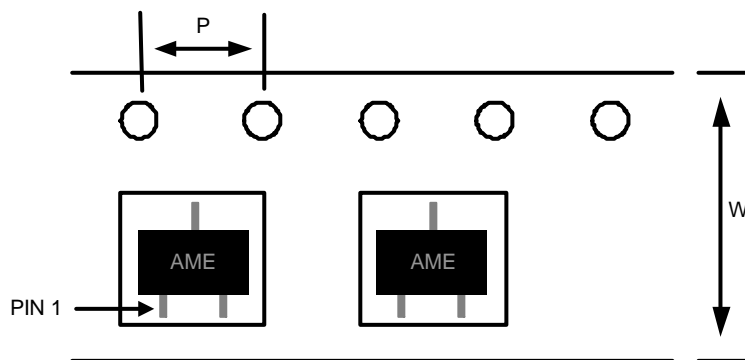
**Forward Characteristic**

**Line Transient Response**

**■ Date Code Rule**

Marking			Date Code		Year
A	A	A	W	W	xxx0
A	A	A	W	<u>W</u>	xxx1
A	A	A	<u>W</u>	W	xxx2
A	A	A	<u>W</u>	<u>W</u>	xxx3
A	A	<u>A</u>	W	W	xxx4
A	A	<u>A</u>	W	<u>W</u>	xxx5
A	A	<u>A</u>	<u>W</u>	W	xxx6
A	A	<u>A</u>	<u>W</u>	<u>W</u>	xxx7
A	<u>A</u>	A	W	W	xxx8
A	<u>A</u>	A	W	<u>W</u>	xxx9

**■ Tape and Reel Dimension**
**SOT-23**

**Carrier Tape, Number of Components Per Reel and Reel Size**

Package	Carrier Width (W)	Pitch (P)	Part Per Full Reel	Reel Size
SOT-23	8.0±0.1 mm	4.0±0.1 mm	3000pcs	180±1 mm

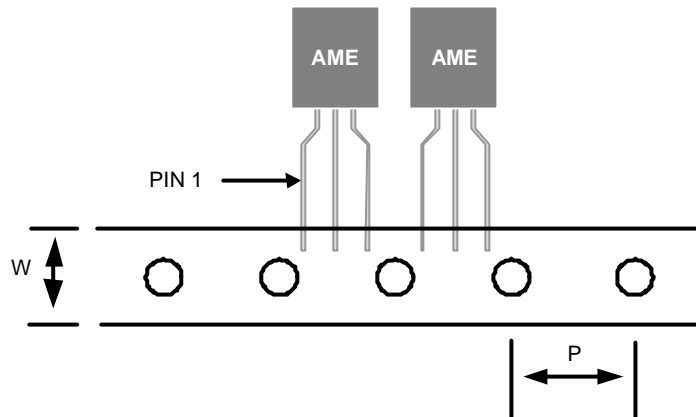

**■ Tape and Reel Dimension**
**TO-92-3**

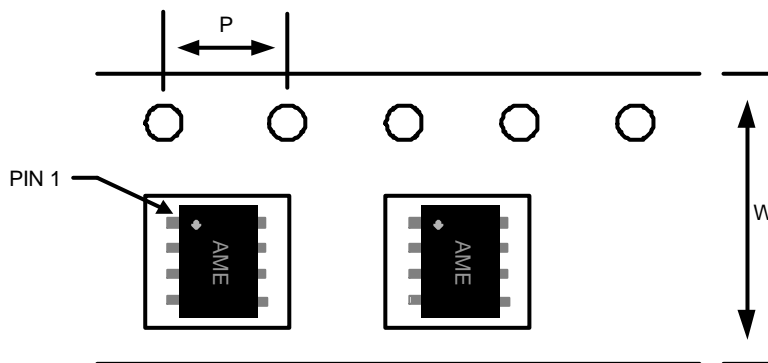
**Carrier Tape, Number of Components Per Reel and Reel Size**

Package	Carrier Width (W)	Pitch (P)	Part Per Full Reel	Reel Size
TO-92-3	18.0 <sup>+1.0</sup> <sub>-0.5</sub> mm	12.7±0.2 mm	2000pcs	N/A

**SOP-8**

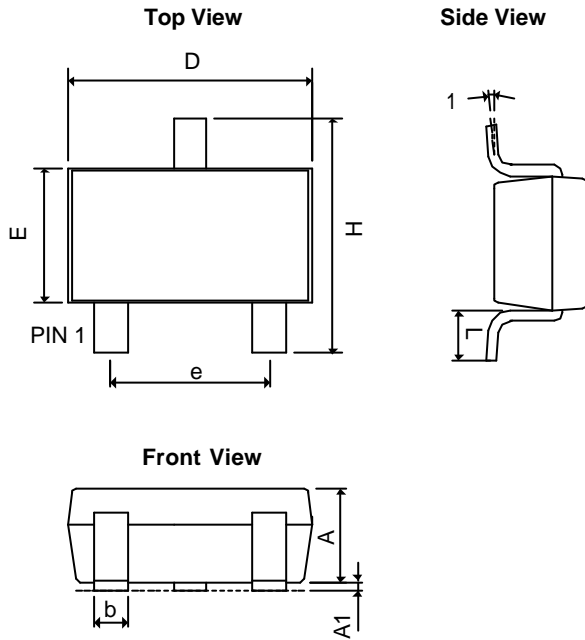
**Carrier Tape, Number of Components Per Reel and Reel Size**

Package	Carrier Width (W)	Pitch (P)	Part Per Full Reel	Reel Size
SOP-8	12.0±0.1 mm	4.0±0.1 mm	2500pcs	330±1 mm

**■ Package Dimension**
**SOT-23**

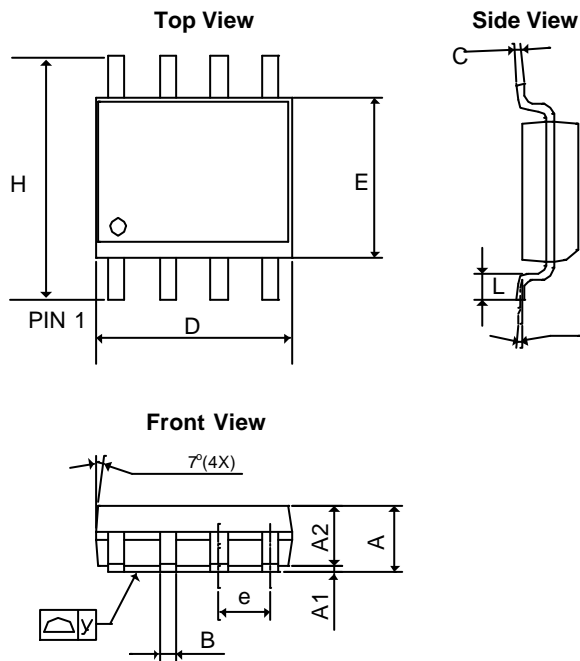
SYMBOLS	MILLIMETERS		INCHES	
	MIN	MAX	MIN	MAX
A	1.00	1.40	0.0394	0.0551
A <sub>1</sub>	0.00	0.15	0.0000	0.0059
b	0.35	0.50	0.0138	0.0197
D	2.70	3.10	0.1063	0.1220
E	1.40	1.80	0.0551	0.0709
e	1.90 BSC		0.0748 BSC	
H	2.40	3.00	0.09449	0.11811
L	0.35BSC		0.0138BSC	
q1	0°	10°	0°	10°

**SOP-8**

SYMBOLS	MILLIMETERS		INCHES	
	MIN	MAX	MIN	MAX
A	1.35	1.75	0.05315	0.0689
A <sub>1</sub>	0.10	0.30	0.00394	0.01181
A <sub>2</sub>	1.473 REF		0.05799 REF	
B	0.33	0.51	0.01299	0.02008
C	0.19	0.25	0.00748	0.00984
D	4.80	5.33	0.18898	0.20984
E	3.80	4.00	0.14961	0.15748
e	1.27 BSC		0.05000 BSC	
L	0.40	1.27	0.01575	0.05000
H	5.80	6.30	0.22835	0.24803
y	-	0.10	-	0.00394
q	0°	8°	0°	8°

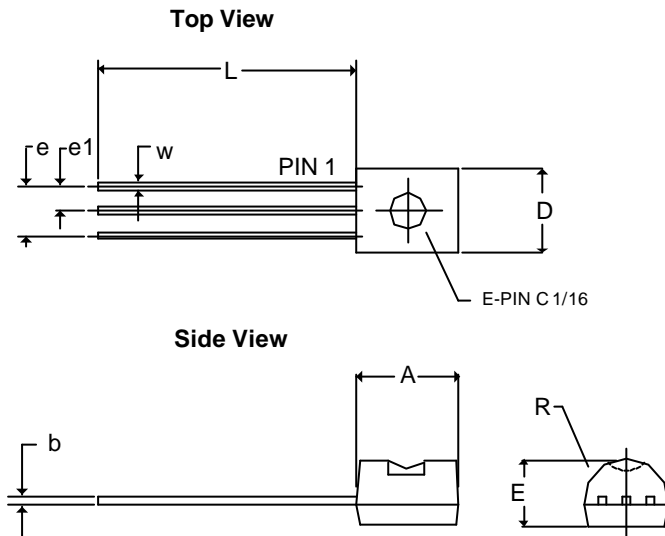
**■ Package Dimension**
**TO-92-3 (bulk pack)**

SYMBOLS	MILLIMETERS		INCHES	
	MIN	MAX	MIN	MAX
<b>A</b>	2.80	4.95	0.1102	0.1949
<b>b</b>	0.40REF		0.0157REF	
<b>E</b>	3.94REF		0.1551REF	
<b>e</b>	2.54REF		0.1000REF	
<b>e1</b>	1.27REF		0.0500REF	
<b>L</b>	12.70	15.49	0.5000	0.6098
<b>R</b>	2.29		0.0902	
<b>W</b>	0.35	0.76	0.0138	0.0299
<b>D</b>	3.80	4.95	0.1496	0.1949

- Notes:
1. Package outline exclusive of any mold flashes dimension.
  2. Package outline exclusive of burr dimension.
  3. Lead pitch=2.54mm is bulk pack.
  4. Lead pitch=5.08mm is tape pack.

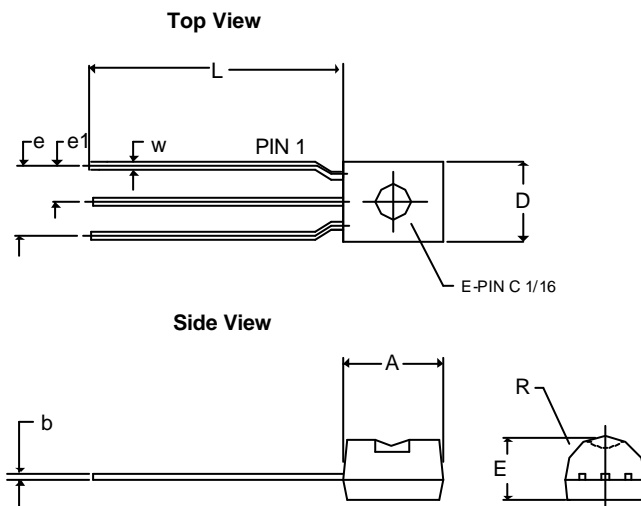
**TO-92-3 (tape pack)**

SYMBOLS	MILLIMETERS		INCHES	
	MIN	MAX	MIN	MAX
<b>A</b>	2.80	4.95	0.1102	0.1949
<b>b</b>	0.40REF		0.0157REF	
<b>E</b>	2.40	3.94	0.0945	0.1551
<b>e</b>	5.08REF		0.2REF	
<b>e1</b>	2.54REF		0.1REF	
<b>L</b>	12.70	15.49	0.5000	0.6098
<b>R</b>	2.00		0.0787	
<b>W</b>	0.35	0.76	0.0138	0.0299
<b>D</b>	3.80	4.95	0.1496	0.1949

- Notes:
1. Package outline exclusive of any mold flashes.
  2. Package outline exclusive of burr dimension.
  3. Lead pitch=2.54mm is bulk pack.
  4. Lead pitch=5.08mm is tape pack.



**www.ame.com.tw**  
**E-Mail: sales@ame.com.tw**

Life Support Policy:

These products of AME, Inc. are not authorized for use as critical components in life-support devices or systems, without the express written approval of the president of AME, Inc.

AME, Inc. reserves the right to make changes in the circuitry and specifications of its devices and advises its customers to obtain the latest version of relevant information.

© AME, Inc. , November 2008

Document: 2003/2037-DS41-ADJ-G.03

**Corporate Headquarter**  
**AME, Inc.**

2F, 302 Rui-Guang Road, Nei-Hu District

Taipei 114, Taiwan.

Tel: 886 2 2627-8687

Fax: 886 2 2659-2989