

# SPECIFICATION FOR APPROVAL

REF :20080805-A

PAGE: 1

PROD. NAME	SHIELDED SMD POWER INDUCTOR	ABC'S DWG NO.	SU1030□□□□F□-□□□
		ABC'S ITEM NO.	

## I . CONFIGURATION & DIMENSIONS :

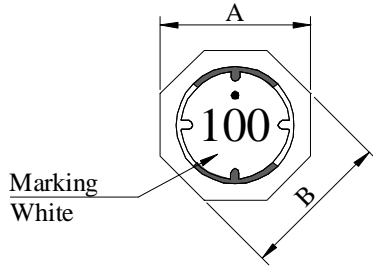

A : 10.00 ±0.30	m/m
B : 10.00 ±0.30	m/m
C : 2.80 ±0.30	m/m
D : 3.00 typ.	m/m
E : 4.00 typ.	m/m
F : 8.20 typ.	m/m
G : 4.20 ref.	m/m
H : 8.20 ref.	m/m
I : 1.40 ref.	m/m

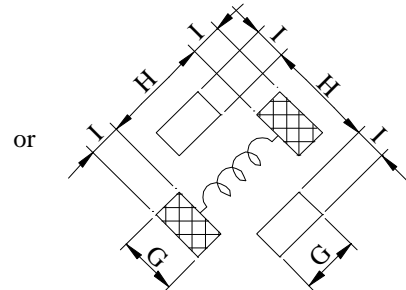
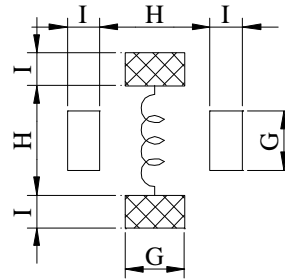
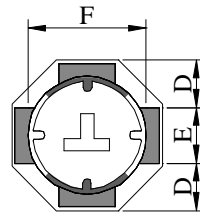
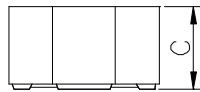

( PCB Pattern )

## II . SCHEMATIC DIAGRAM :

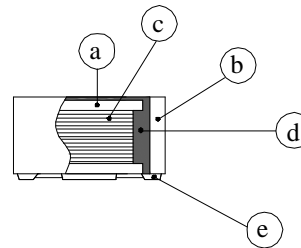
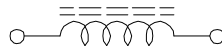

## III . MATERIALS :

- a . Core : Ferrite DR core
- b . Core : Ferrite RI core
- c . Wire : Enamelled copper wire (Class F &H)
- d . Adhesive : Epoxy resin
- e . Terminal : Ag/Ni/Sn
- f . Remark : Products comply with RoHS' requirements

Peak Temp : 260°C max.  
 Max time above 230°C : 50sec max.  
 Max time above 200°C : 70sec max.

## IV . GENERAL SPECIFICATION :

- a . Temp. rise : 40°C typ.
- b . Rated current :  
 Base on temp. rise &  $\Delta L / LOA = 35\%$  typ.
- c . Storage temp. : -40°C ---- +125°C
- d . Operating temp. : -40°C ---- +105°C
- e . Resistance to solder heat : 260°C .10 secs.

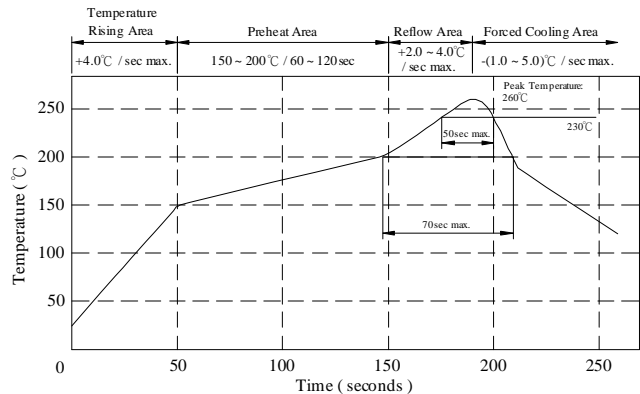

AR-001A

# SPECIFICATION FOR APPROVAL

PROD. NAME	SHIELDED SMD POWER INDUCTOR	ABC'S DWG NO.	SU1030□□□□F□-□□□
		ABC'S ITEM NO.	

### V . ELECTRICAL CHARACTERISTICS :

DWG No.	Inductance ( μH )	Q ref.	SRF (MHz) typ.	RDC (mΩ)		Irms (A) typ.	Isat (A) typ.
				typ.	max.		
SU10303R5YF□-□□□	3.5 ±30%	16	45	20.5	27.0	5.00	5.20
SU10304R7YF□-□□□	4.7 ±30%	14	36	25.0	32.5	4.20	4.40
SU10306R2YF□-□□□	6.2 ±30%	12	30	32.0	42.0	3.80	3.90
SU1030100YF□-□□□	10.0 ±30%	16	26	44.0	58.0	3.00	3.10
SU1030150YF□-□□□	15.0 ±30%	16	22	73.0	95.0	2.60	2.55
SU1030220YF□-□□□	22.0 ±30%	16	18	110.0	145.0	2.00	2.10
SU1030330YF□-□□□	33.0 ±30%	12	14	150.0	195.0	1.70	1.74
SU1030470YF□-□□□	47.0 ±30%	14	12	210.0	270.0	1.40	1.35
SU1030680YF□-□□□	68.0 ±30%	14	10	285.0	370.0	1.20	1.22
SU1030101YF□-□□□	100.0 ±30%	14	8.5	395.0	520.0	1.10	1.02
SU1030151YF□-□□□	150.0 ±30%	12	5.5	640.0	840.0	0.85	0.84

- 1) . □ : Packaging Information... [A] : Bulk [B] : Taping Reel
- 2) . "-□□□":Reference code
- 3) . Inductance Test Freq. : 100KHz / 0.1V
- 4) . Q Test Freq. : 3R5~6R2--7.96MHz , 100~680--2.52MHz , 101~151--0.796MHz
- 5) . Isat base on  $\Delta L / LOA=35\%$  typ.
- 6) . Irms base on Temp. rise 40°C typ.

@ Inductance VS. DC Superposition Characteristics

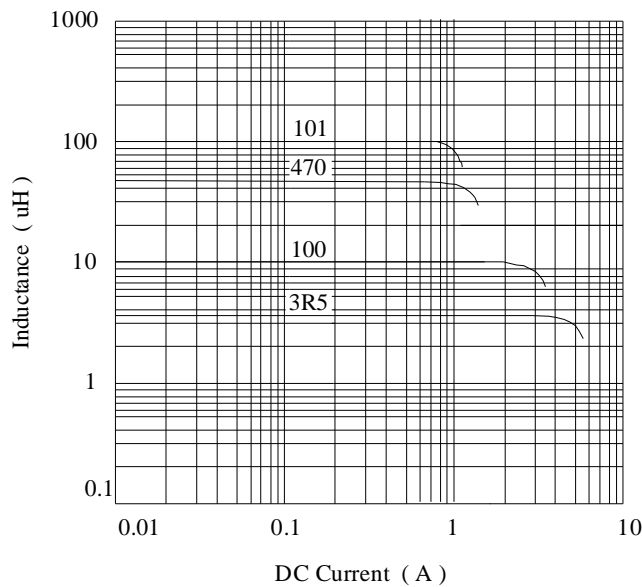

# SPECIFICATION FOR APPROVAL

REF :20080805-A

PAGE: 3

PROD. NAME	SHIELDED SMD POWER INDUCTOR	ABC'S DWG NO.	SU1030□□□□F□-□□□
		ABC'S ITEM NO.	

## VI . PACKAGING INFORMATION :

### ( 1 ) Configuration

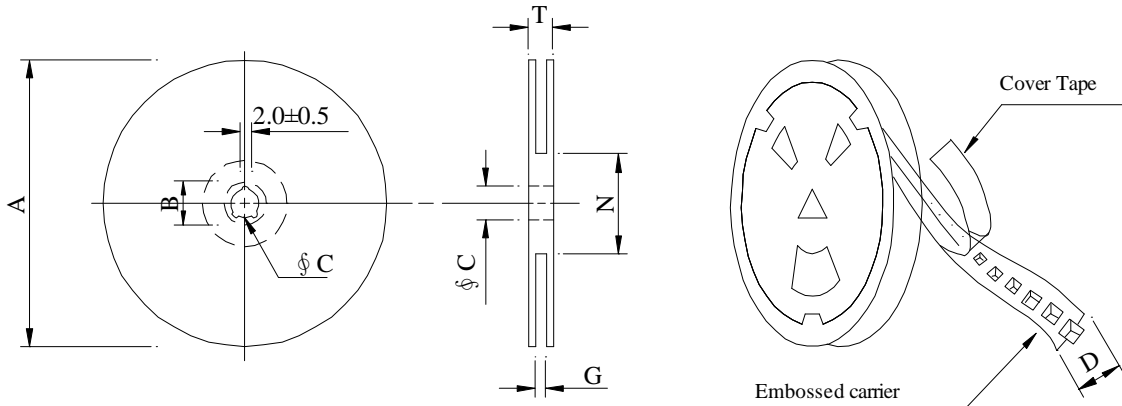

※Carrier tape width : D

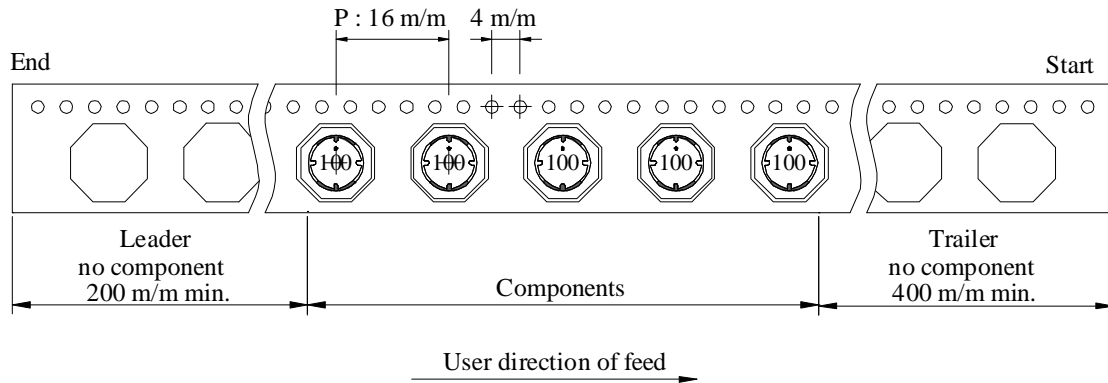

### ( 2 ) Dimensions

Unit:m/m

Style	A	B	C	D	G	N	T
13 - 24	330	21±0.8	13±0.5	24	26 <sup>+0</sup>	50 <sup>-0</sup>	30.4

### ( 3 ) QTY & G.W. Per package

Series	Inner : Reel			Outer : Carton		
	Q'TY (pcs)	G.W. (gw)	Style	Q'TY (pcs)	G.W. (Kg)	Size (cm)
SU1030	1200	1,800	13 - 24	4,800	10	40 x 40 x 24

AR-001A



# SPECIFICATION FOR APPROVAL

REF :20080805-A

PAGE: 4

PROD.	SHIELDED SMD	ABC'S DWG NO.	SU1030□□□□F□-□□□
NAME	POWER INDUCTOR	ABC'S ITEM NO.	

**VII . DWGING NUMBER EXPRESSION :**

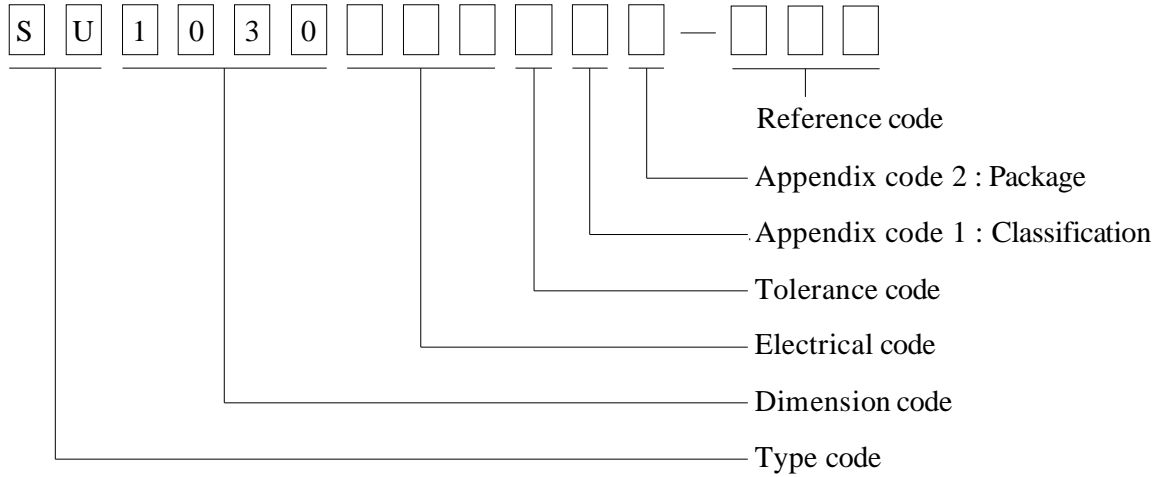

**Appendix code 1 : Product Classification**

- F : Lead Free Standard products comply with RoHS' requirements
- 1 ~ 9 : Lead Free Special products comply with RoHS' requirements

**Appendix code 2 : Package Information**

Code	Inner package	Inner package Q'TY	Remark
A	T.B.D.	T.B.D.	
B	T / R ( Reel package )	1200 pcs	

AR-001A

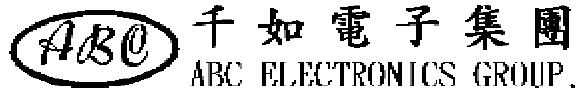

# SPECIFICATION FOR APPROVAL

REF :20080805-A

PAGE: 5

PROD.	SHIELDED SMD	ABC'S DWG NO.	SU1030□□□□F□-□□□
NAME	POWER INDUCTOR	ABC'S ITEM NO.	

**VIII . RELIABILITY TEST :**

Test item	Specification	Test condition						
Solderability	More than 95% of the terminal electrode shall be covered With fresh solder.	Preheat : 155°C / 4 hours. Solder : Sn96.5 / Ag3 / Cu0.5 or equivalent Solder temp. : 235±5°C Flux : Rosin Dip time : 5±0.5 seconds						
Thermal shock test ( Temp. cycle )	Electrical oharacteristics shall not change more than ±20%	<table style="width: 100%; border: none;"> <tr> <td style="text-align: center;">Room temp. 15 minutes</td> <td style="text-align: center;">→</td> <td style="text-align: center;">-40 °C 30 minutes</td> </tr> <tr> <td style="text-align: center;">Room temp. 15 minutes</td> <td style="text-align: center;">→</td> <td style="text-align: center;">+105 °C 30 minutes</td> </tr> </table> <p>Total : 50 cycles</p>	Room temp. 15 minutes	→	-40 °C 30 minutes	Room temp. 15 minutes	→	+105 °C 30 minutes
Room temp. 15 minutes		→	-40 °C 30 minutes					
Room temp. 15 minutes		→	+105 °C 30 minutes					
Humidity test		Temperature : 40±2°C Humidity : 90±5% Time : 1000 hours						
High temp. Resistance test	Temperature : 105±5°C Applied current : Per spec. Time : 96 hours							

AR-001A



# SPECIFICATION FOR APPROVAL

REF :20080805-A

PAGE: 6

PROD.	SHIELDED SMD	ABC'S DWG NO.	SU1030□□□□F□-□□□
NAME	POWER INDUCTOR	ABC'S ITEM NO.	

**IX . UL CARD :**

OBMW2 September 8, 2000

Magnet Wire-Component

JUNG SHING WIRE CO LTD E174837

231 CHUNG CHENG RD, SEC 3 JEN-TEH HSIANG, TAINAN

HSIEN TAIWAN

Mtl Dsg	Mark Dsg	BC	Coat Typ	OC	ANSI Type	Temp Class
AIW	---	Polyamideimide	---	---	MW81-C	220
CFUEWB	---	Polyurethane	---	---	MW75C	130
EIAIW	---	Polyesterimide	Polyamideimide	---	MW35C	200
EILOCKY	---	Polyesterimide	Polyamide	---	---	180
EILOCKW	---	Polyesterimide	Modified Epoxy	---	---	200
EIW	---	Polyesterimide	---	---	---	220
EIW-2	---	Polyesterimide	---	---	MW74-C	200
FL.EILOCKY	---	Modified Polyester	Polyamide	---	---	155
LSFFW	---	Polyurethane	---	---	MW79-C	155
LSUEW	---	Polyurethane	---	---	---	130
PEW	---	Polyester	---	---	---	155
PEY	---	Polyester	Nylon	---	MW24-C	155
SF.FLW	---	Modified Polyester	---	---	MW26C	155
SF.EIW	---	Polyesterimide	---	---	MW77C	180
SF.BY@	---	Modified Polyester	Nylon	---	MW27-C	155
SF.FLY@	---	Modified Polyester	Nylon	---	MW27-C	155
SF.BLOCKBS	---	Modified Polyester	Modified Polyamide	---	---	155
SF.EILOCKY#	---	Polyesterimide	Polyamide	---	---	180
SF.EILOCKBS	---	Polyesterimide	Modified Polyamide	---	---	180
SF.BW@	---	Modified Polyester	---	---	MW26C	155
SFFW	---	Polyurethane	---	---	MW79	155

28780602 Page 1 of 2

Mtl Dsg	Mark Dsg	BC	Coat Typ	OC	ANSI Type	Temp Class
SFFY	---	Polyurethane	Polyamide	---	MW80C	155
UEW-1	---	Polyurethane	---	---	MW2-C	105
UEW-2	---	Polyurethane	---	---	---	130
UEW-4	---	Polyurethane	---	---	MW75C	130
UEY	---	Polyurethane	Nylon	---	MW28-C	130
UEY-2	---	Polyurethane	Polyamide	---	MW28-C	130

@ - May be suffixed by LZ; # - May be suffixed by LZ, EL or LZL  
 LZ - Signifies magened wires twisted together; EL - signifies base coated magnet wire laid parallel with top coat applied overall; LZL - signifies base coated magnet wire twisted together and covered with top coat overall.

Marking: Company name or trademarks **(JSW)** or 聚晶電線, material designation or marked designation on packaed or reel, and Recognized Component Mark.

See General Information Preceding These Recognitions  
 For use only in equipment where the acceptability of the combination is determined by Underwriters Laboratories Inc.

28780602 Page 2 of 2

OBMW2/E174837  
September 8, 2000

AR-001A



# SPECIFICATION FOR APPROVAL

REF :20080805-A

PAGE: 7

PROD. NAME	SHIELDED SMD POWER INDUCTOR	ABC'S DWG NO.	SU1030□□□□F□-□□□
		ABC'S ITEM NO.	

OBMW2 August 27, 1999

Magnet Wire-Component

ELEKTRISOLA (MALAYSIA) SDN BHD E143312

IALAN DAMN SATU IANDA BAIK 28750 BENTONG, PAHANG  
DARUL MAKMUR MALAYSIA

Mtl Dsg	Mark Dsg	Coating Type		ANSI Typ	Temp Class
		BC	OC		
Estersol 160	E180	Polyesterimide (solderable)	—	MW-77	180
Amldester 200	A200	Polyesterimide	—	MW-74	200
Polysol-N 155	PN155	Polyurethane	Nylon	MW-80,	155,
				MW-28	100
Polysol 155	P155	Polyurethane	—	MW-79,	155,
				MW-79	130
Polysol 155g	Pg155	Polyurethane	—	MW-79	130
Polysol 155p	Pp155,Gp155	Polyurethane	—	MW-79	155
Polysol 160	P160	Polyurethane	—	MW-79	155
Polysol 180	P180	Polyurethane	—	MW-79	155
Polysol 170	P170 or G170	Polyurethane	—	MW-79	156
Polysol-N 180	PN180	Polyurethane	Nylon	—	180

Marking : Company name/material designation or marked designation and factory identification on package ok reel

---

See General Information preceding These Recognitions  
For use only in equipment where the acceptability of the combination is determined by Underwriters Laboratories Inc.

AR-001A

