

Silicon PNP Power Transistors

2SB727K

DESCRIPTION

- With TO-220C package
- Complement to type 2SD768K
- DARLINGTON

APPLICATIONS

- For medium speed and power switching applications

PINNING

PIN	DESCRIPTION
1	Base
2	Collector; connected to mounting base
3	Emitter

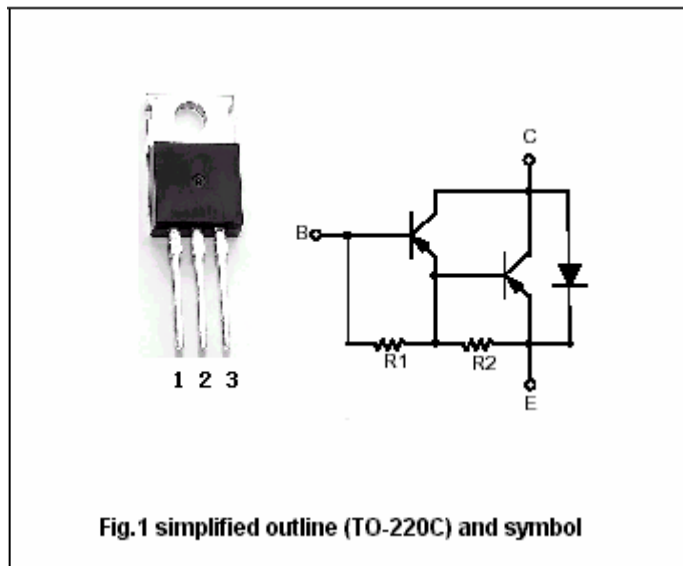

Fig.1 simplified outline (TO-220C) and symbol

Absolute maximum ratings(Ta=25)

SYMBOL	PARAMETER	CONDITIONS	VALUE	UNIT
V _{CBO}	Collector-base voltage	Open emitter	-120	V
V _{CEO}	Collector-emitter voltage	Open base	-120	V
V _{EBO}	Emitter-base voltage	Open collector	-7	V
I _C	Collector current		-6	A
I _{CM}	Collector current-peak		-10	A
P _C	Collector power dissipation	T _C =25	40	W
T _j	Junction temperature		150	
T _{stg}	Storage temperature		-55~150	

Silicon PNP Power Transistors

2SB727K

CHARACTERISTICS

T_j=25 unless otherwise specified

SYMBOL	PARAMETER	CONDITIONS	MIN	TYP.	MAX	UNIT
V _{(BR)CEO}	Collector-emitter breakdown voltage	I _C =-25mA, R _{BE} =	-120			V
V _{(BR)EBO}	Emitter-base breakdown voltage	I _E =-50mA, I _C =0	-7			V
V _{CEsat-1}	Collector-emitter saturation voltage	I _C =-3A, I _B =-6mA			-1.5	V
V _{CEsat-2}	Collector-emitter saturation voltage	I _C =-6A, I _B =-60mA			-3.0	V
V _{BEsat-1}	Base-emitter saturation voltage	I _C =-3A, I _B =-6mA			-2.0	V
V _{BEsat-2}	Base-emitter saturation voltage	I _C =-6A, I _B =-60mA			-3.5	V
I _{CBO}	Collector cut-off current	V _{CB} =-120V, I _E =0			-100	μA
I _{CEO}	Collector cut-off current	V _{CE} =-100V, R _{BE} =			-10	μA
h _{FE}	DC current gain	I _C =-3A; V _{CE} =-3V	1000		20000	

Switching times

t _{on}	Turn-on time	I _C =-3A, I _{B1} =-I _{B2} =-6mA		1.0		μs
t _{off}	Turn-off time			3.0		μs

Silicon PNP Power Transistors

2SB727K

PACKAGE OUTLINE

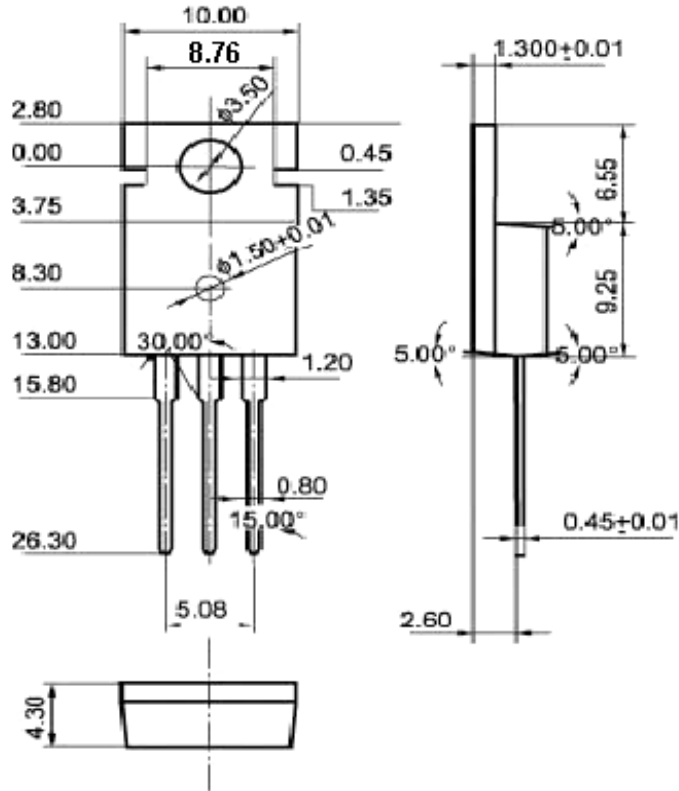

Fig.2 Outline dimensions

Silicon PNP Power Transistors

2SB727K

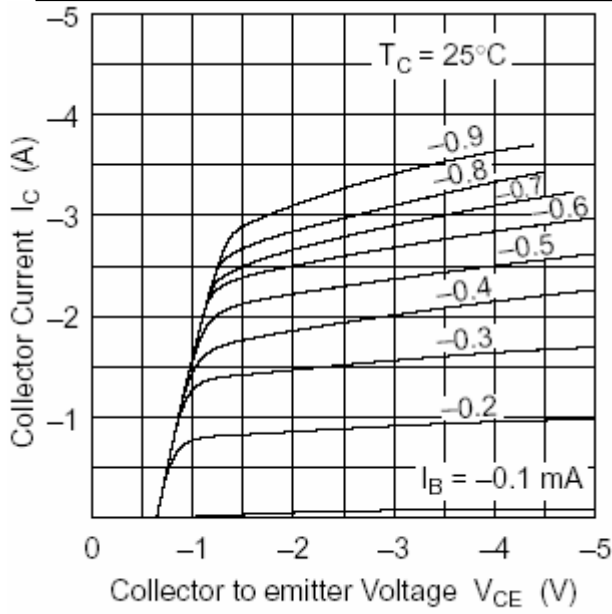

Fig.3 Static Characteristic

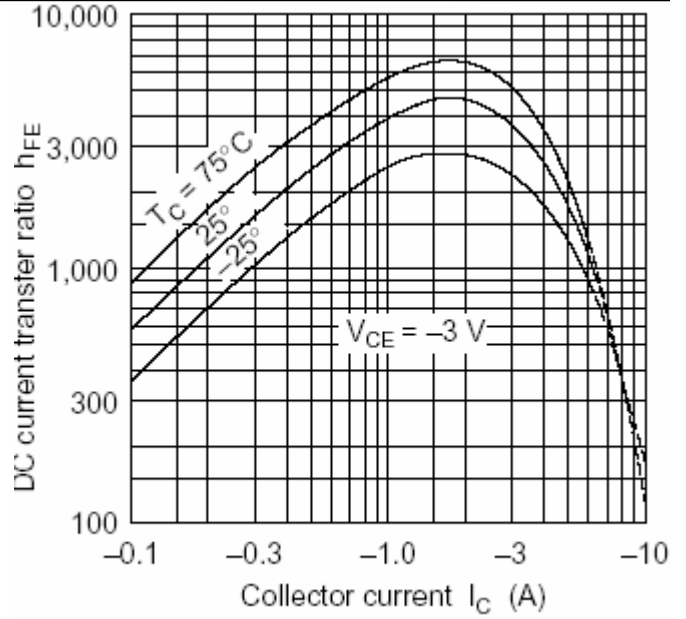

Fig.4 DC current Gain

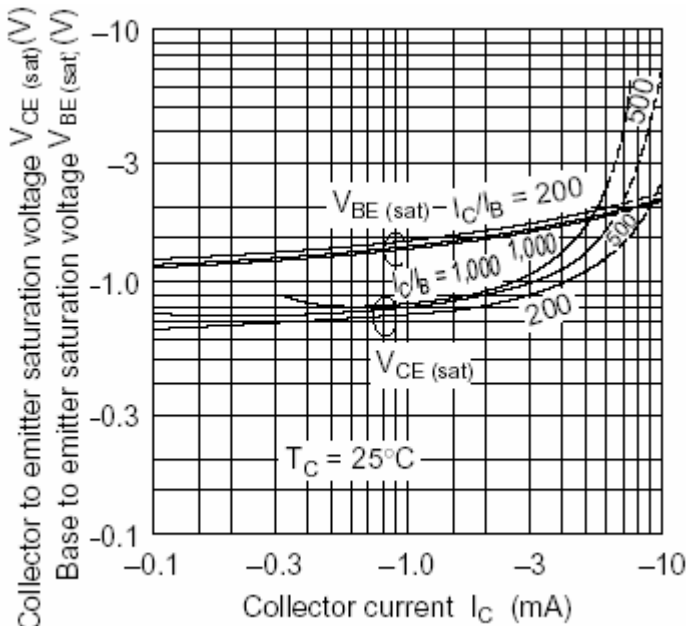

Fig.5 Collector-Emitter Saturation Voltage

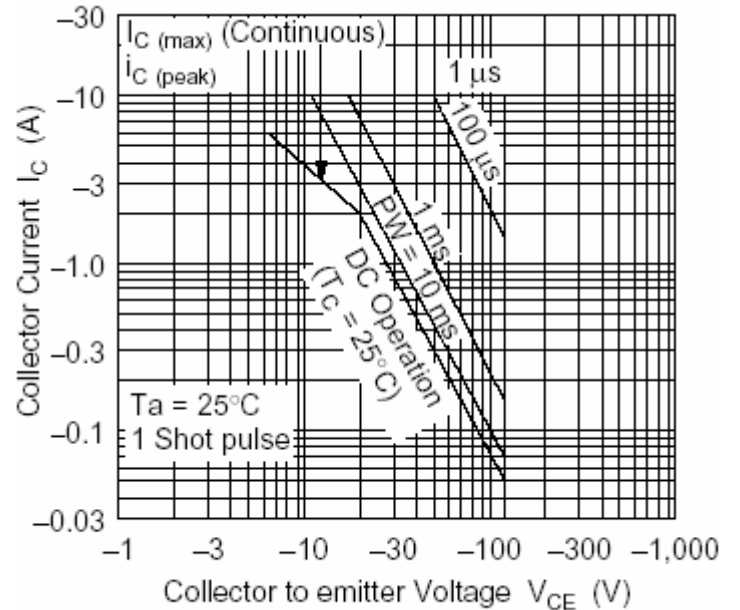

Fig.6 Safe Operating Area