

## Low Power 4X Multiplier EMI Reduction IC

### Features

- Generates a 4X EMI optimized clock signal at the output.
- Integrated loop filter components.
- Operates with a 3.3 / 2.5V Supply.
- Low power CMOS design.
- Input frequency range: 12MHz to 30MHz for 2.5V.  
: 12MHz to 30MHz for 3.3V.
- Frequency deviation: -1.5% (Typ) @66MHz Output Frequency.
- Available in 6-pin TSOT-23 Package.

The ASM3P2274A uses the most efficient and optimized modulation profile approved by the FCC and is implemented by using a proprietary all digital method.

The ASM3P2274A modulates the output of a single PLL in order to “spread” the bandwidth of a synthesized clock, and more importantly, decreases the peak amplitudes of its harmonics. This results in significantly lower system EMI compared to the typical narrow band signal produced by oscillators and most frequency generators. Lowering EMI by increasing a signal’s bandwidth is called ‘spread spectrum clock generation’.

### Product Description

The ASM3P2274 is a versatile Spread Spectrum Frequency Modulator designed specifically for a wide range of clock frequencies. It provides a 4x Spread Spectrum Modulated output from an input clock source.

The ASM3P2274A reduces electromagnetic interference (EMI) at the clock source, allowing system wide reduction of EMI of all clock dependent signals. The ASM3P2274A allows significant system cost savings by reducing the number of circuit board layers ferrite beads, shielding that are traditionally required to pass EMI regulations.

### Applications

The ASM3P2274A is targeted towards all portable devices with very low power requirements like MP3 players, MFP, LCD Panel Module and digital still cameras.

### Key Specifications

Description	Specification
Supply voltages	VDD = 3.3V / 2.5V
Cycle-to-Cycle Jitter	360pS (Typ)
Output Duty Cycle	45/55%
Modulation Rate Equation	$F_{IN}/640$
Frequency Deviation	-1.5% (Typ) @ 66MHz Output

### Block Diagram

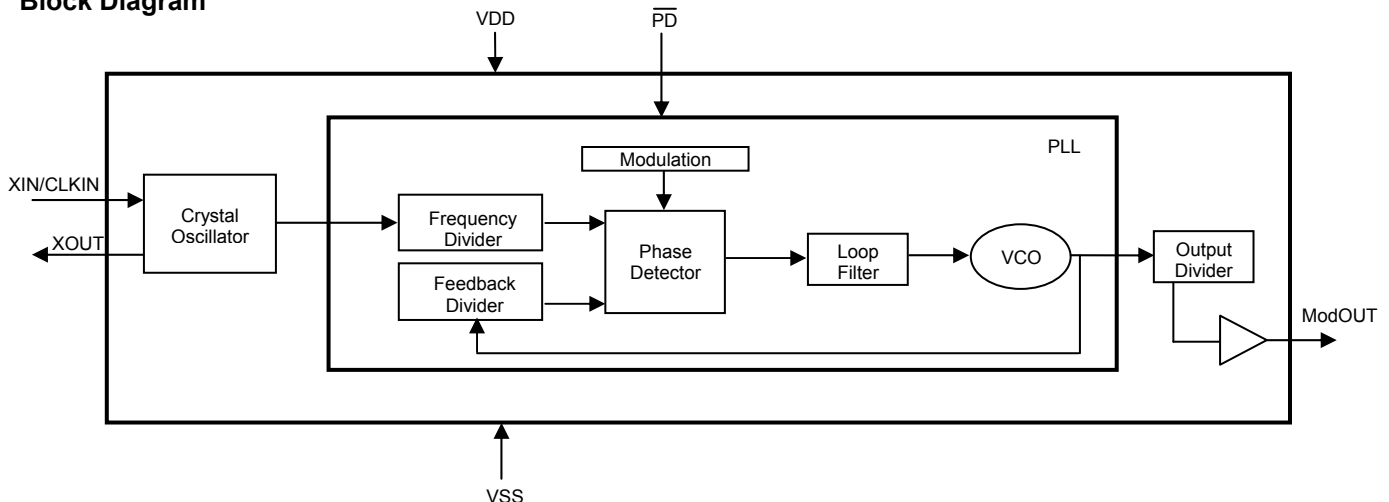

rev 1.1

Pin Configuration (6-pin TSOT- 23 Package)

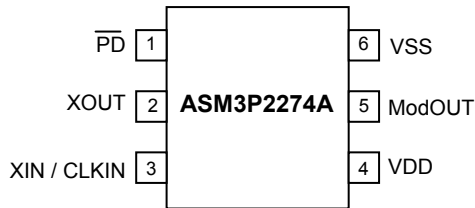

Pin Description

Pin#	Pin Name	Type	Description
1	$\overline{PD}$	I	Power-down control pin. Pull low to enable power-down mode. Connect to VDD if not used.
2	XOUT	O	Crystal connection. If using an external reference, this pin must be left unconnected.
3	XIN / CLKIN	I	Crystal connection or external reference frequency input. This pin has dual functions. It can be connected either to an external crystal or an external reference clock.
4	VDD	P	Power supply for the entire chip.
5	ModOUT	O	Spread spectrum clock output (4X output)
6	VSS	P	Ground connection.

Modulation Profile

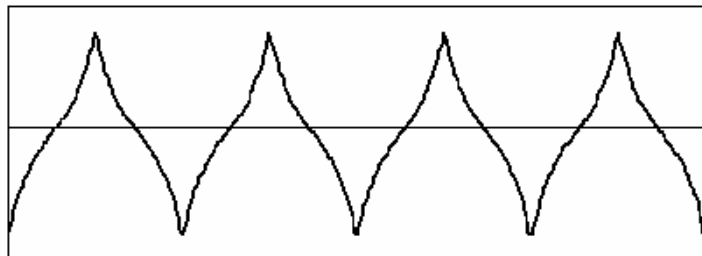

Specifications

Description		Specification
Input Frequency Range	For 2.5V Supply	12MHz < CLKIN < 30MHz
	For 3.3V Supply	12MHz < CLKIN < 30MHz
Modulation Equation		$F_{IN}/640$
Frequency Deviation		-1.5% (Typ) @ 66MHz Output

rev 1.1

**Absolute Maximum Ratings**

Symbol	Parameter	Rating	Unit
VDD, V <sub>IN</sub>	Voltage on any pin with respect to Ground	-0.5 to +4.6	V
T <sub>STG</sub>	Storage temperature	-65 to +125	°C
T <sub>A</sub>	Operating temperature	-40 to +85	°C
T <sub>s</sub>	Max. Soldering Temperature (10 sec)	260	°C
T <sub>J</sub>	Junction Temperature	150	°C
T <sub>DV</sub>	Static Discharge Voltage (As per JEDEC STD22- A114-B)	2	KV

Note: These are stress ratings only and are not implied for functional use. Exposure to absolute maximum ratings for prolonged periods of time may affect device reliability.

**DC Electrical Characteristics for 2.5V Supply**

(Test condition: All parameters are measured at room temperature (+25°C) unless otherwise stated)

Symbol	Parameter	Min	Typ	Max	Unit
V <sub>IL</sub>	Input low voltage	VSS - 0.3	-	0.8	V
V <sub>IH</sub>	Input high voltage	2.0	-	VDD + 0.3	V
I <sub>IL</sub>	Input low current	-	-	-35	µA
I <sub>IH</sub>	Input high current	-	-	35	µA
I <sub>XOL</sub>	XOUT output low current (@0.5V, VDD=2.5V)	-	3	-	mA
I <sub>XOH</sub>	XOUT output high current (@1.8V, VDD=2.5V)	-	3	-	mA
V <sub>OL</sub>	Output low voltage (VDD = 2.5V, I <sub>OL</sub> = 8 mA)	-	-	0.6	V
V <sub>OH</sub>	Output high voltage (VDD = 2.5V, I <sub>OH</sub> = 8 mA)	1.8	-	-	V
I <sub>DD</sub>	Static supply current*	-	-	2	uA
I <sub>CC</sub>	Dynamic supply current (2.5V, 66MHz and no load)	-	3.0	-	mA
VDD	Operating voltage	2.375	2.5	2.625	V
t <sub>ON</sub>	Power-up time (first locked cycle after power-up)**	-	-	5	mS
Z <sub>OUT</sub>	Output impedance	-	50	-	Ω

\* XIN /CLKIN pin and  $\overline{PD}$  pin are pulled low

\*\* VDD and XIN/CLKIN input are stable,  $\overline{PD}$  pin is made high from low.

**AC Electrical Characteristics for 2.5V Supply**

Symbol	Parameter	Min	Typ	Max	Unit	
CLKIN	Input frequency	12	-	30	MHz	
ModOUT	Output frequency	48	-	120	MHz	
f <sub>d</sub>	Frequency Deviation	Output Frequency = 48MHz	-	-1.6	-	%
		Output Frequency = 120MHz	-	-1.4	-	
t <sub>LH</sub> *	Output rise time (measured from 0.7V to 1.7V)	0.5	2.0	2.3	nS	
t <sub>HL</sub> *	Output fall time (measured from 1.7V to 0.7V)	0.4	1.0	1.2	nS	
t <sub>JC</sub>	Jitter (Cycle to cycle)	-	360	-	pS	
t <sub>D</sub>	Output duty cycle	40	50	60	%	

\* t<sub>LH</sub> and t<sub>HL</sub> are measured into a capacitive load of 15pF

rev 1.1

**DC Electrical Characteristics for 3.3V Supply**

(Test condition: All parameters are measured at room temperature (+ 25°C) unless otherwise stated)

Symbol	Parameter	Min	Typ	Max	Unit
V <sub>IL</sub>	Input low voltage	VSS - 0.3	-	0.8	V
V <sub>IH</sub>	Input high voltage	2.0	-	VDD + 0.3	V
I <sub>IL</sub>	Input low current	-	-	-35	μA
I <sub>IH</sub>	Input high current	-	-	35	μA
I <sub>XOL</sub>	XOUT output low current (@0.4V, VDD=3.3V)	-	3	-	mA
I <sub>XOH</sub>	XOUT output high current (@2.5V, VDD=3.3V)	-	3	-	mA
V <sub>OL</sub>	Output low voltage (VDD = 3.3V, I <sub>OL</sub> = 8 mA)	-	-	0.4	V
V <sub>OH</sub>	Output high voltage (VDD = 3.3V, I <sub>OH</sub> = 8 mA)	2.5	-	-	V
I <sub>DD</sub>	Static supply current*	-	-	2	uA
I <sub>CC</sub>	Dynamic supply current (3.3V, 66MHz and no load)	-	4.0	-	mA
VDD	Operating voltage	3.0	3.3	3.6	V
t <sub>ON</sub>	Power-up time (first locked cycle after power-up)**	-	-	5	mS
Z <sub>OUT</sub>	Output impedance	-	45	-	Ω

\* XIN /CLKIN pin and  $\overline{PD}$  pin are pulled low  
 \*\* VDD and XIN/CLKIN input are stable, PD pin is made high from low.

**AC Electrical Characteristics for 3.3V Supply**

Symbol	Parameter	Min	Typ	Max	Unit	
CLKIN	Input frequency	12	-	30	MHz	
ModOUT	Output frequency	48	-	120	MHz	
f <sub>d</sub>	Frequency Deviation	Output Frequency = 48MHz	-	-1.6	-	%
		Output Frequency = 120MHz	-	-1.4	-	
t <sub>LH</sub> *	Output rise time (measured from 0.8 to 2.0V)	0.4	1.3	1.6	nS	
t <sub>HL</sub> *	Output fall time (measured at 2.0V to 0.8V)	0.4	0.8	1.1	nS	
t <sub>JC</sub>	Jitter (Cycle to cycle)	-	360	-	pS	
t <sub>D</sub>	Output duty cycle	40	50	60	%	

\*t<sub>LH</sub> and t<sub>HL</sub> are measured into a capacitive load of 15pF

rev 1.1

Typical Crystal Oscillator Circuit

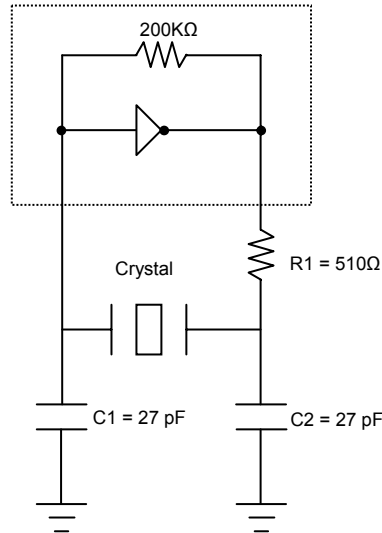

Typical Crystal Specifications

Fundamental AT cut parallel resonant crystal	
Nominal frequency	14.31818MHz
Frequency tolerance	± 50 ppm or better at 25°C
Operating temperature range	-25°C to +85°C
Storage temperature	-40°C to +85°C
Load capacitance	18pF
Shunt capacitance	7pF maximum
ESR	25 Ω

Package Information

6-pin TSOT-23 Package

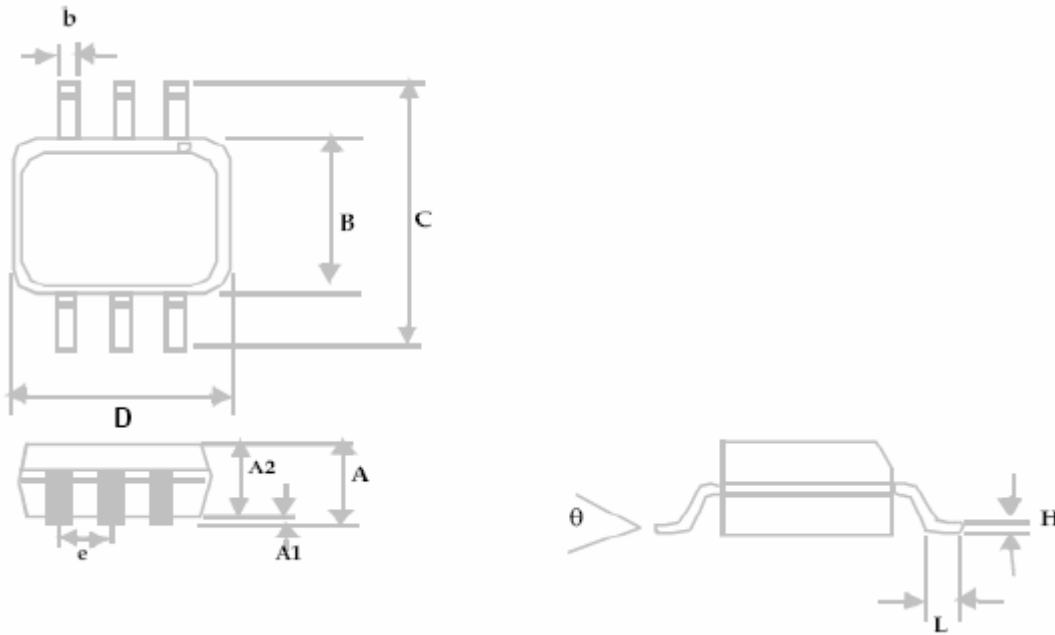

Symbol	Dimensions			
	Inches		Millimeters	
	Min	Max	Min	Max
A		0.04		1.00
A1	0.00	0.004	0.00	0.10
A2	0.033	0.036	0.84	0.90
b	0.012	0.02	0.30	0.50
H	0.005 BSC		0.127 BSC	
D	0.114 BSC		2.90 BSC	
B	0.06 BSC		1.60 BSC	
e	0.0374 BSC		0.950 BSC	
C	0.11 BSC		2.80 BSC	
L	0.0118	0.02	0.30	0.50
theta	0°	4°	0°	4°

rev 1.1

Ordering Information

Part Number	Marking	Package Type	Temperature
ASM3P2274AG-06-OR	Z3	6-Pin TSOT-23, TAPE & REEL, Green	Commercial
ASM3I2274AG-06-OR	Z6	6-Pin TSOT-23, TAPE & REEL, Green	Industrial

Device Ordering Information

ASM3P2274AF-06-OR

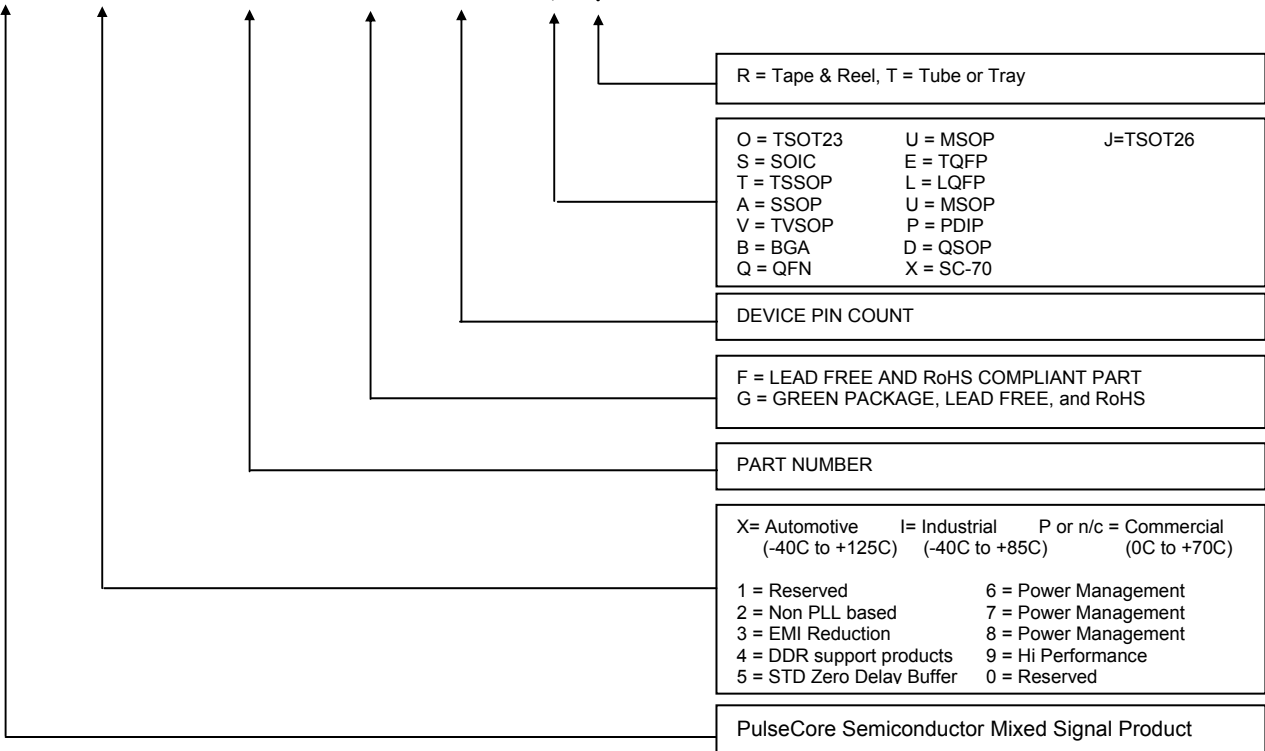

Licensed under U.S Patent Nos 5,488,627 and 5,631,921



PulseCore Semiconductor Corporation  
1715 S. Bascom Ave Suite 200  
Campbell, CA 95008  
Tel: 408-879-9077  
Fax: 408-879-9018  
www.pulsecoresemi.com

Copyright © PulseCore Semiconductor  
All Rights Reserved  
Part Number: ASM3P2274A  
Document Version: v1.1

Note: This product utilizes US Patent # 6,646,463 Impedance Emulator Patent issued to PulseCore Semiconductor, dated 11-11-2003

© Copyright 2006 PulseCore Semiconductor Corporation. All rights reserved. Our logo and name are trademarks or registered trademarks of PulseCore Semiconductor. All other brand and product names may be the trademarks of their respective companies. PulseCore reserves the right to make changes to this document and its products at any time without notice. PulseCore assumes no responsibility for any errors that may appear in this document. The data contained herein represents PulseCore's best data and/or estimates at the time of issuance. PulseCore reserves the right to change or correct this data at any time, without notice. If the product described herein is under development, significant changes to these specifications are possible. The information in this product data sheet is intended to be general descriptive information for potential customers and users, and is not intended to operate as, or provide, any guarantee or warranty to any user or customer. PulseCore does not assume any responsibility or liability arising out of the application or use of any product described herein, and disclaims any express or implied warranties related to the sale and/or use of PulseCore products including liability or warranties related to fitness for a particular purpose, merchantability, or infringement of any intellectual property rights, except as express agreed to in PulseCore's Terms and Conditions of Sale (which are available from PulseCore). All sales of PulseCore products are made exclusively according to PulseCore's Terms and Conditions of Sale. The purchase of products from PulseCore does not convey a license under any patent rights, copyrights; mask works rights, trademarks, or any other intellectual property rights of PulseCore or third parties. PulseCore does not authorize its products for use as critical components in life-supporting systems where a malfunction or failure may reasonably be expected to result in significant injury to the user, and the inclusion of PulseCore products in such life-supporting systems implies that the manufacturer assumes all risk of such use and agrees to indemnify PulseCore against all claims arising from such use.