

SURFACE MOUNT

- High capacitance range complimenting the standard DS range
- Available in X7R, X5R, Y5V and Z5U
- Suitable for many applications including digital consumer goods and high resolution LCD displays

CERAMIC SMD MULTI-LAYER HIGH CAPACITANCE DS

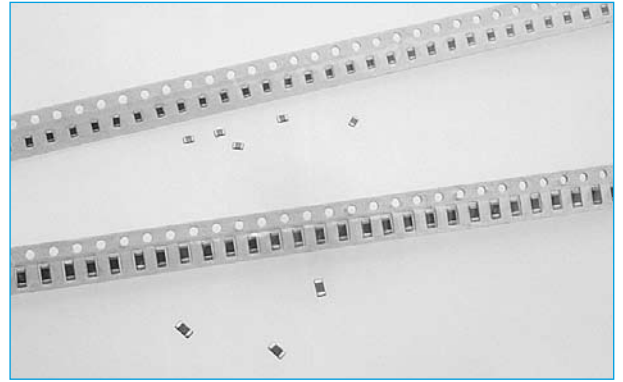

SECTION 1

OUTLINE DRAWING

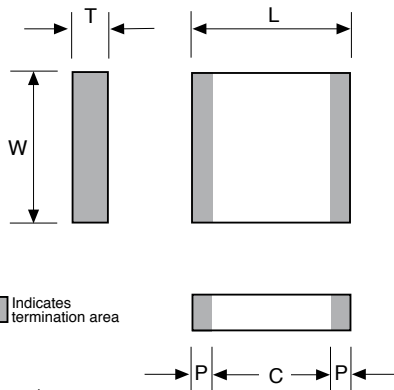

	L	W	T	P
Size Code	mm	mm	mm	mm
0402	1.0±0.1	0.5±0.05	0.6 MAX	0.2
0603	1.6±0.15	0.8±0.1	0.9 MAX	0.3
0805	2.0±0.2	1.25±0.15	1.3 MAX	0.5
1206	3.2±0.2	1.6±0.15	1.3 MAX	0.5
1210	3.2±0.3	2.5±0.3	1.7 MAX	0.5
1812	4.5±0.3	3.2±0.3	1.6 MAX	0.5

TOLERANCE

DIELECTRIC MATERIALS, CAPACITANCE VALUES AND TOLERANCE AVAILABLE

Dielectric	Available Tolerance	Capacitance	Tolerance Codes
X7R	+/- 10%, +/- 20%	As Tables	K=10% M=20%
X5R	+/- 10%, +/- 20%	As Tables	K=10% M=20%
Y5V	+/- 20%, -20% + 80%	As Tables	M=20% Z= -20% + 80%
Z5U	+/- 20%, -20% + 80%	As Tables	M=20% Z= -20% + 80%

ORDERING INFORMATION

DS	B	0805	X	106	K	N
Part	Voltage	Size	Dielectric	Value	Tolerance	Plating
	U = 50 E = 25V C = 16V B = 10V D = 6.3V	0402 0603 0805 1206 1210 1812	R = X7R X = X5R G = Y5V W = Z5U	Example 104 = 100nF 105 = 1µF 106 = 10µF	K = 10% M = 20% Z = 20+80%	N = Nickel barrier

RANGE

SECTION 1

Capacitance	Dielectric		X7R									
	Case Size		0603			0805			1206			1210
	16	25	50	10	16	25	50	16	25	50	25	
Rated Voltage (VDC)	16	25	50	10	16	25	50	16	25	50	25	
0.15uF (154)	x		x									
0.22uF (224)	x	x									x	
0.33uF (334)	x								x	x		
0.47uF (474)	x							x	x	x		
1.0uF (105)	x					x	x	x	x	x		
1.5uF (155)				x	x			x	x			
2.2uF (225)				x	x			x	x		x	
3.3uF (335)								x	x		x	
4.7uF (475)								x	x		x	
10uF (106)											x	

Capacitance	Dielectric		X5R																
	Case Size		0402			0603			0805				1206				1210		
	6.3	10	6.3	10	16	25	6.3	10	16	25	6.3	10	16	25	10	16	25		
Rated Voltage (VDC)	6.3	10	6.3	10	16	25	6.3	10	16	25	6.3	10	16	25	10	16	25		
0.22uF (224)		x		x	x	x													
0.33uF (334)				x	x	x											x		
0.47uF (474)				x	x	x								x			x		
0.68uF (684)				x	x	x								x			x		
0.82uF (824)				x	x	x								x			x		
1.0uF (105)	x	x	x	x	x	x	x	x	x	x	x						x		
1.2uF (125)								x	x	x							x		
1.5uF (155)								x	x	x		x	x	x	x				
1.8uF (185)								x	x	x		x	x	x	x				
2.2uF (225)	x			o	o	o		x	x	x		x	x	x	x	o	o	o	
3.3uF (335)								x	x	x		x	x	x	x	o	o	o	
4.7uF (475)				o				x	x	x		x	x	x	x	o	o	o	
6.8uF (685)												x	x	x		o	o	o	
8.2uF (825)												x	x	x		o	o	o	
10uF (106)				o				x	x	x		x	x	x	o	o	o	o	
12uF (126)																o	o		
15uF (156)																o	o		
22uF (226)				F				o				x				o	o		
33uF (336)																			
47uF (476)														o					
100uF (107)																			

F=Future
o=Reflow Only

General Purpose Ceramic Chip Capacitors Y5V/Z5U Nickel Barrier Terminations																	
Capacitance	Dielectric		Y5V/Z5U														
	Case Size		0603				0805				1206			1210		1812	
	10	16			6.3	10	16	25	10	16	25	16	25	35	16	25	
Rated Voltage (VDC)	10	16			6.3	10	16	25	10	16	25	16	25	35	16	25	
1.5uF (155)	x					x	x				x						
2.2uF (225)	x					x	x				x		x				
3.3uF (335)						x	x		x		x		x				
4.7uF (475)						x	x		x	x			x				
6.8uF (685)						x			x	x			x				
10uF (106)						x			x	x		x	x	x		x	
22uF (226)						x			x				x				
47uF (476)						x											
100uF (107)						x										x	

TAPE DIMENSIONS (mm)

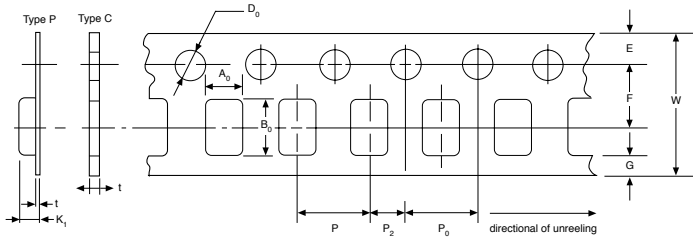

W	Type	D0	P	P0	P2	E	F	G	t
8.0 ± 0.3	C	1.5 +0.1, -0	4.0 ± 0.1	4.0 ± 0.1	2.0 ± 0.05	1.75 ± 0.1	3.5 ± 0.05	0.75 min	1.1 max
8.0 ± 0.3	P	1.5 +0.1, -0	4.0 ± 0.1	4.0 ± 0.1	2.0 ± 0.05	1.75 ± 0.1	3.5 ± 0.05	0.75 min	0.3 max
12.0 ± 0.3	P	1.5 +0.1, -0	8.0 ± 0.1	4.0 ± 0.1	2.0 ± 0.05	1.75 ± 0.1	5.5 ± 0.05	0.75 min	0.1 max

C = Card P = Plastic

REEL DIMENSIONS (mm)

Nom. Tape Width	A	W1
8	180 or 330 +0-2	8.4 +1.5-0
12	180 or 330 +0-2	12.4 +2-0

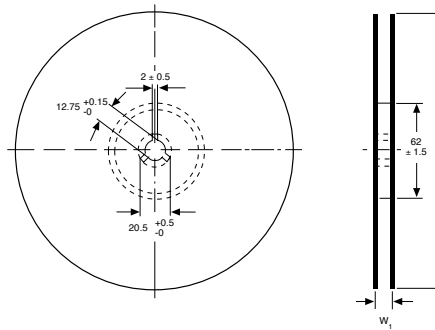

PERFORMANCE CHARACTERISTICS

PERFORMANCE CHARACTERISTICS				
1. ELECTRICAL				
Dielectric Code	X7R	X5R	Y5V	Z5U
General	X7R dielectrics offer higher capacitance for a given case size than COG.	X5R dielectrics offer higher capacitance for a given case size than X7R.	Y5V dielectrics offer the highest capacitance for a given case size than X5R.	Z5U dielectrics offer the highest capacitance for a given case size than Y5V.
Examples of Applications	Applications would include bypass, coupling and filtering circuits.	Applications would include bypass, coupling and filtering circuits.	Applications would include bypass and decoupling circuits or where temperature dependence is not of major importance.	Applications would include bypass and decoupling circuits or where temperature dependence is not of major importance.
Temperature Range	-55° to + 125°	- 55° to + 85°	- 25° to + 85°	- 25° to + 85°
Insulation Resistance (I.R.) after 1 min charging at Rated Voltage	>100G ohms or 1000 sec whichever is less	>100G ohms or 1000sec whichever is less.	>10G ohms or 100 sec whichever is less.	>10G ohms or 100 sec whichever is less.
Voltage Ratings dc	10, 16, 25, 50	10,16,25	10, 16, 25, 35	10, 16, 25, 35
Proof Voltage	2.5 x rated voltage	2.5 X rated voltage.	2 x rated voltage	2.5 x rated voltage
Max allowable Capacitance Variation over Temperature Range	± 15%	± 15%	+30% to - 80%	+22% to - 56%

2. ENVIRONMENT				
Test	Conditions	Requirement		
Resistance to soldering heat	Components completely immersed in a solder bath at 260 ± 10° for 5 secs.	25% Max leaching on each edge		
Adhesion	Component mounted to substrate a force of 5N applied normal to the line joining the termination and in a line parallel to the substrate.	No visible damage		
Rapid change or Temperature	- 55 to 125°C, 5 cycles (1B, 2C1) - 25 to +85°, 5 cycles (2F4)	No visible damage. After recovery		
		Δ C/C	≤±1% or pF	COG
		Δ C/C	≤±10%	X7R
		Δ C/C	≤±10%	X5R
		Δ C/C	≤±20%	Y5V
Tan		≤1.5 x specified value		
IR.		≤0.25 x specified value		