

规格书编号

SPEC NO :

# 产品规格书

# SPECIFICATION

CUSTOMER 客户: \_\_\_\_\_  
PRODUCT 产品: **SAW FILTER**  
MODEL NO 型号: **HDIF45A10Dc SIP5Dc**  
PREPARED 编制: \_\_\_\_\_ CHECKED 审核: \_\_\_\_\_  
APPROVED 批准: \_\_\_\_\_ D A T E 日期: 2008-6-25

客户确认 CUSTOMER RECEIVED:		
审核 CHECKED	批准 APPROVED	日期 DATE

无锡市好达电子有限公司  
Shoulder Electronics Limited



**1.SCOPE**

SHOULDER's SAW filter series have broad line up products meeting all broadcast standard including NTSC,PAL and SECAM systems. These filters are composed of two interdigital transducers on a single-crystal, piezoelectrical chip. they are used in electronic equipments such as TV and so on.

**2.Construction**

**2.1 Dimension and materials**

Manufacturer's name : SHOULDER ELECTRONICS LTD

Type : IF45A10Dc

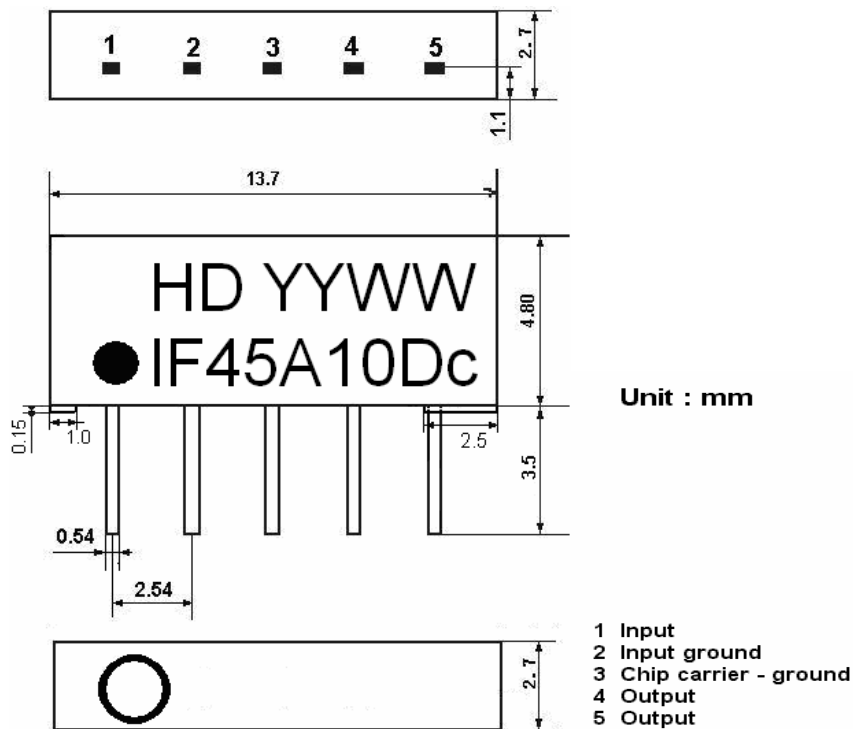

YY:year  
WW:week

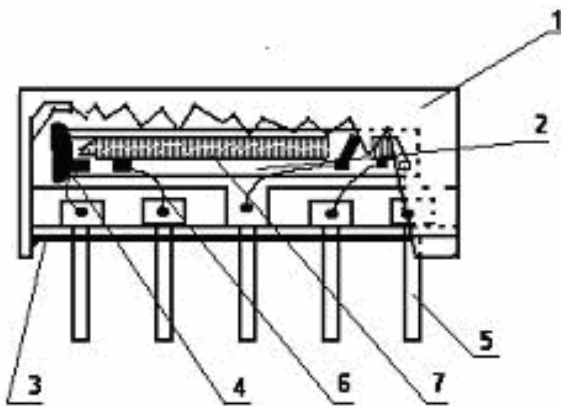

Components	Materials
1.Outer casing	PPS
2.Substrate	Lithium niobate
3.Base	Epoxy resin
4.Absorber	Epoxy resin
5.Lead	Cu alloy·Au plate
6.Bonding wire	AlSi alloy
7.Electrode	Al

**2.2. Circuit construction, measurement circuit**

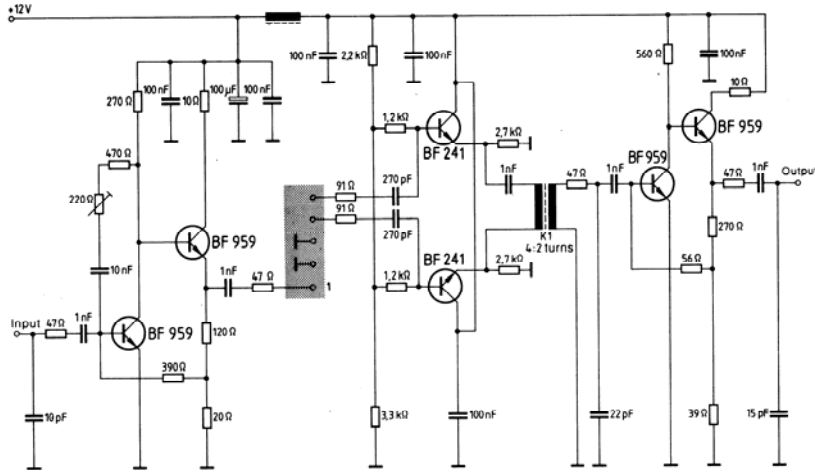

Test circuit for SIP-5 filter  
Input impedance of the symmetrical post-amplifier: 2 kΩ in parallel with 3 pF

**3.Characteristics**

Items	Conditions	Specifications
Standard atmospheric conditions	Unless otherwise specified , the standard rang of atmospheric conditions for making measurements and tests is as follows; Ambient temperature : 15°C to 35°C Relative humidity : 25% to 85% Air pressure : 86kPa to 106kPa	There shall be no damage.
Operating temperature rang	Operating temperature rang is the rang of ambient temperatures in which the filter can be operated continuously. -10°C ~ +60°C	
Storage temperature rang	Storage temperature rang is the rang of ambient temperatures at which the filter can be stored without damage. Conditions are as specified elsewhere in these specifications. -40°C ~ +70°C	
Reference temperature	+25°C	

### 3.1 Maximum Rating

<b>DC voltage</b>	<b>VDC</b>	<b>12</b>	<b>V</b>	<b>Between any terminals</b>
<b>AC voltage</b>	<b>Vpp</b>	<b>10</b>	<b>V</b>	<b>Between any terminals</b>

### 3.2 Electrical Characteristics

Source impedance

$Z_S=50\ \Omega$

Load impedance

$Z_L=2k\ \Omega //3pF$

$T_A=25^\circ C$

		Freq	Min	typ	max	
<b>Insertion attenuation</b>	Reference level	44.00MHz	9.4	11.4	13.4	dB
	<b>Relative attenuation</b>	45.75MHz	3.6	5.1	6.6	dB
42.17MHz		3.7	5.2	6.7	dB	
41.25MHz		17.7	19.7	21.7	dB	
39.75MHz		42.0	55.0		dB	
47.25MHz		41.0	48.0		dB	
<b>Sidelobe</b>	35.00~39.75MHz	35.0	41.0		dB	
	47.25~55.00MHz	35.0	40.0		dB	
Temperature coefficient			-72			ppm/k

### 3.3 Environmental Performance Characteristics

Item	Condition	Specifications
High temperature	The specimen shall be store at a temperature of $80\pm 2^\circ C$ for $96\pm 4h$ . Then it shall be subjected to standard atmospheric conditions for 1h, after which measurement shall be made within 1h.	Mechanical characteristics and specifications in electrical characteristics shall be satisfied. There shall be no excessive change in appearance.
Low temperature	The specimen shall be store at a temperature of $-20\pm 3^\circ C$ for $96\pm 4h$ . Then it shall be subjected to standard atmospheric conditions for 1h, after which measurement shall be made within 1h.	
Humidity	The specimen shall be store at a temperature of $40\pm 2^\circ C$ with relative humidity of 90% to 96% for $96\pm 4h$ . Then it shall be subjected to standard atmospheric conditions for 1h, after which measurement shall be made within 1h.	
Thermal shock	The specimen shall be subjected to 8 continuous cycles each as shown below. Then it shall be subjected to standard atmospheric conditions for 1h, after which measurement shall be made within 1h.	

	Temperature	Duration
1	+25 °C=>-40 °C	0.5h
2	-40 °C	4h
3	-40 °C=>+85 °C	2h
4	+85 °C	4h
5	+85 °C=>+25 °C	0.5h
6	+25 °C	1h

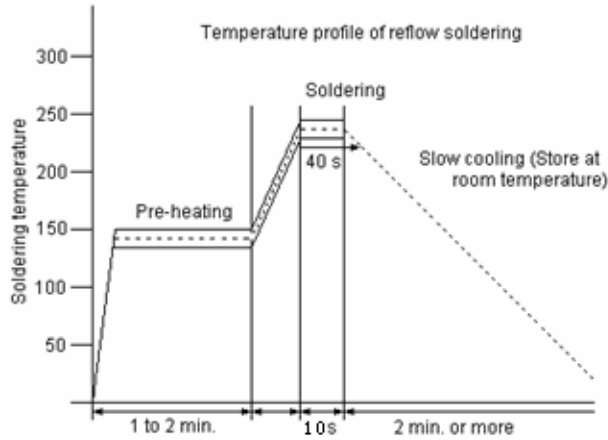

<p>Resistance to Soldering heat</p>	<p>Reflow soldering method Peak: 255 ±5 °C, 220 ±5 °C, 40s At electrode temperature of the specimen.</p>  <p>The specimen shall be passed through the reflow furnace with the condition shown in the above profile for 1 time. The specimen shall be stored at standard atmospheric conditions for 1h, after which the measurement shall be made. Test board shall be 1.6 mm thick. Base material shall be glass fabric base epoxy resin.</p>	
<p>Solder ability</p>	<p>Immerse the pins melt solder at 260°C+5/-0°C for 5 sec.</p>	<p>More then 95% of total area of the pins should be covered with solder</p>

**3.4 Mechanical Test**

Items	Conditions	Specifications
Vibration	600-3300rpm amplitude 1.5mm 3 directions 2 H each	There shall be no damage.
Drop	On maple plate from 1 m high 3 times	
Lead pull	Pull with 1 kg force for 30 seconds	
Lead bend	90° bending with 500g weigh 2 times	

**3.5 Voltage Discharge Test**

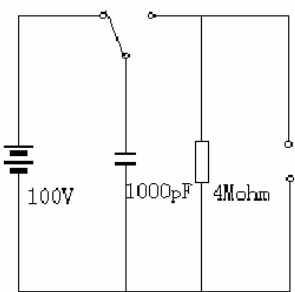
Item	Condition	Specifications
Surge	Between any two electrode 	There shall be no damage

**3.6 Frequency response:**

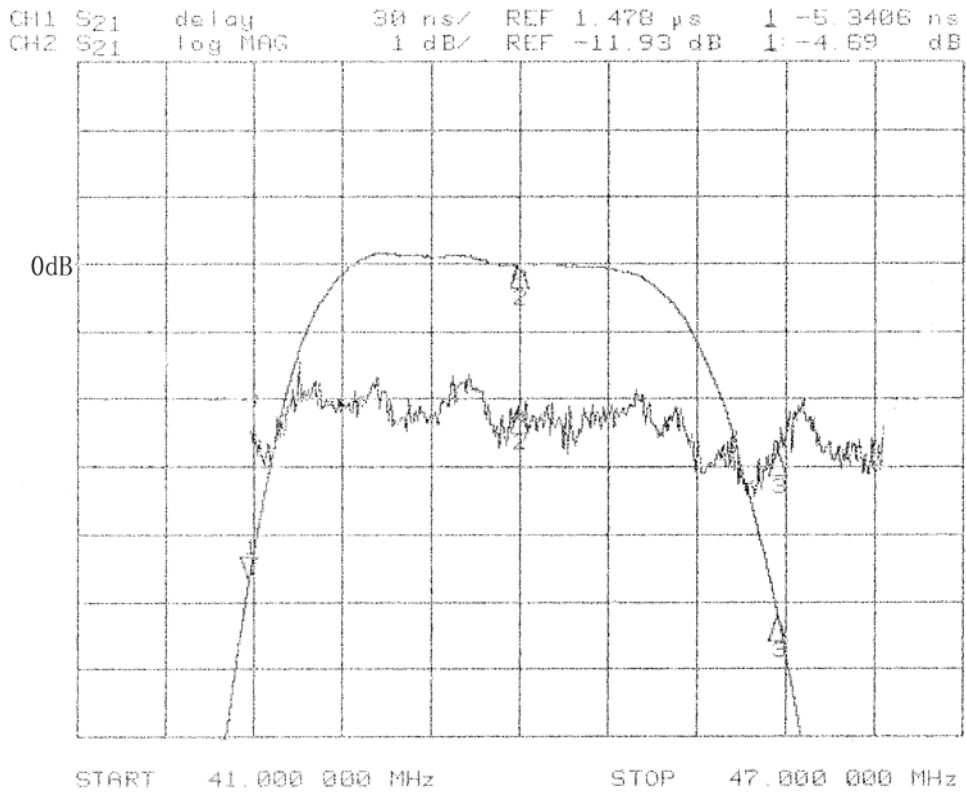
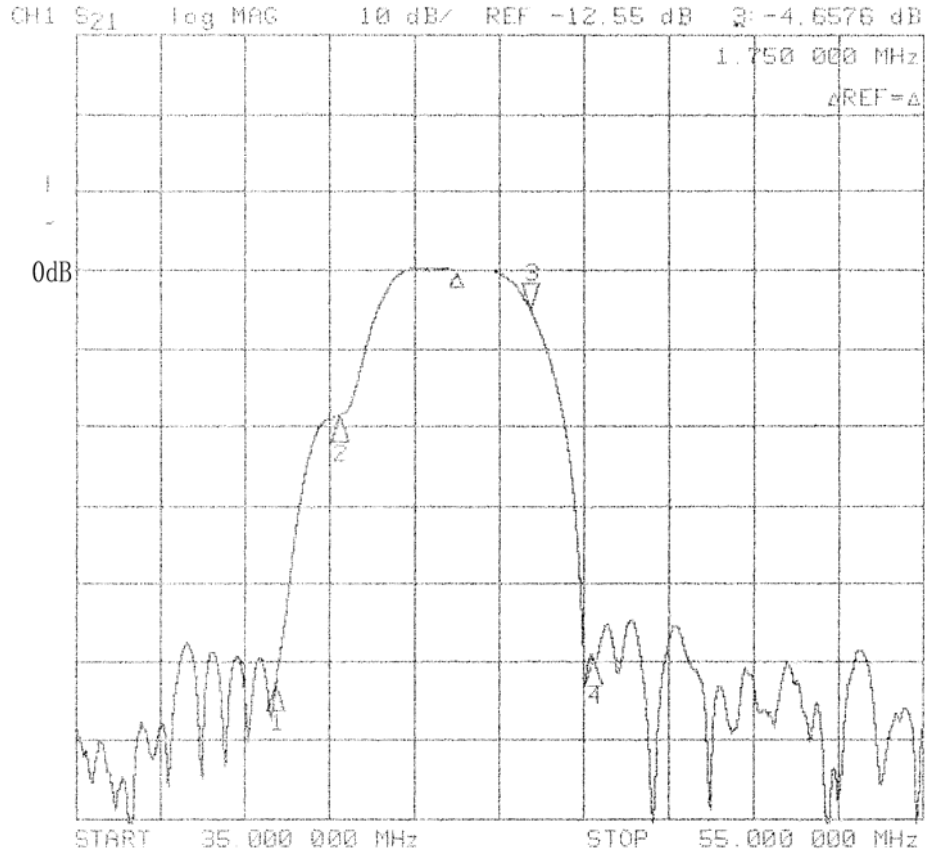



Time domain response:

