

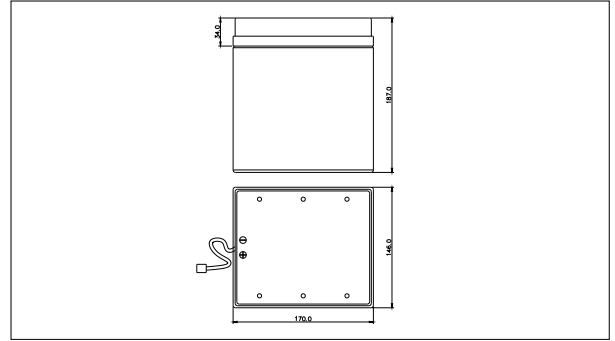

SW2418(24V18AH)



● Outer dimensions (mm)



● Specifications

Nominal Voltage		24V
Rated capacity (20hour rate)		18.0 Ah
Dimensions	Total Height	187mm (7.36inches)
	Height	187mm (7.36inches)
	Length	170mm (6.69inches)
	Width	146mm (5.75inches)
Weight Approx		11.0Kg (24.25 lbs)

● Terminal Type (mm)

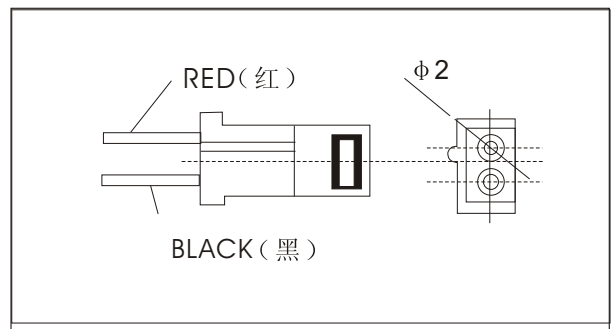

● Characteristics

Capacity 25°C(77°F)	20 hour rate(0.175A)	18.00 AH
	10 hour rate(0.32A)	16.56AH
	5 hour rate(0.60A)	13.50AH
	1 hour rate(2.1A)	10.80AH
	1.5 hour discharge to 10.5V	7.74A
Internal Resistance	Full charged Battery at 25°C(77°F)	25m Ω
Capacity affected by Temperature (20hour rate)	40°C(104°F)	102%
	25°C(77°F)	100%
	0°C(32°F)	85%
	-15°C(5°F)	65%
Self-Discharge at 25°C(77°F)	Capacity after 3 month storage	91%
	Capacity after 6 month storage	82%
	Capacity after 12 month storage	64%
Terminal	Tw10	
Charge (constant Voltage)	Cycle	Initial Charging Current less than 7.2A Voltage 28.80-29.40V
	Float	Voltage 27.0-27.60V

● Discharge Curves 25°C(77°F)

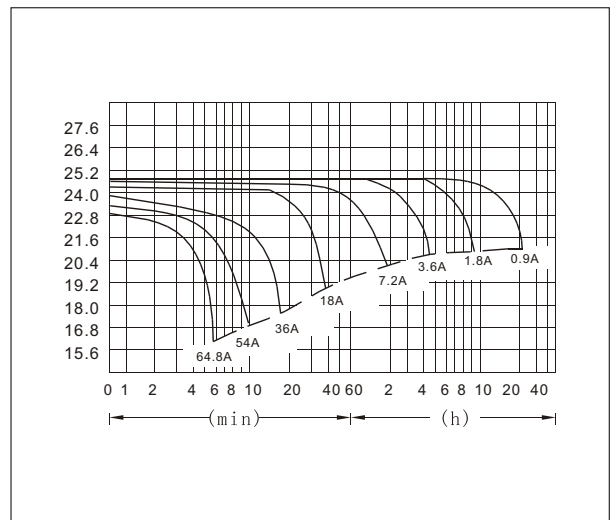

Constant Current(Amp) and Constant Power(Watt) Discharge Table at 25°C(77°F)

Time		5min	10min	15min	30min	1h	2h	3h	4h	5h	8h	10h	20h
19.20v	A	64.8	42.5	31.5	20.7	10.8	6.30	4.64	3.72	3.16	2.08	1.70	0.93
	W	1346	912	675	446	234	138.3	103.2	83.7	71.9	47.9	39.3	21.6
20.40v	A	59.4	40.6	28.9	19.7	10.1	6.04	4.50	3.60	3.10	2.05	1.67	0.91
	W	1277	909	648	441	230	139.4	104.3	83.7	72.2	47.9	39.3	21.3
21.00v	A	54.1	38.0	27.0	19.0	9.8	5.93	4.42	3.42	3.08	2.03	1.66	0.90
	W	1188	864	617	438	227	137.4	103.1	80.1	71.7	47.7	39.2	21.3
21.60v	A	52.0	36.3	25.2	18.5	9.5	5.77	4.35	3.36	2.93	1.97	1.61	0.88
	W	1166	837	581	429	221	135.3	102.6	79.4	69.2	46.8	38.4	20.9
22.20v	A	48.1	34.2	23.4	18.0	9.1	5.63	4.13	3.30	2.80	1.92	1.58	0.86
	W	1091	792	545	422	215	133.1	98.0	78.6	66.8	46.1	38.1	20.7