

Straight DIP Type



FEATURE

- DIP-type connector mounted directly on PCB. Contact tail is straight, allowing vertical mounting of connector on PCB.
- Number of contacts : 9, 15, 25 and 37
- Press-fabricated contacts. Standard surface finishing of contacts : Connections Au-plated (0.4μ) on Ni-substrata, tails Sn-Ag plated.
- To fasten engagement with counterpart, an engaging block and a hexagon-head nut can be attached, allowing connection of PCB's and metal shell's grounding and improving resistance against EMI.

SPECIFICATION

Voltage Rating	300V AC (r.m.s.)
Current Rating	5A/Contact
Dielectric Withstanding Voltage	1,000V AC (r.m.s.) for 1 minute
Insulation Resistance	1,000M Ω min. at 500V DC
Contact Resistance	15m Ω max.
Temperature	-25°C to +85°C

MATERIAL/FINISH

P/N	MATERIAL/FINISH
Block	Polyamide resin (UL94V-0)/Black
Shell	Steel/Nickel Plating
Contact	Copper alloy/Mating area : 0.4μ m, Gold over Nickel Plating Tail area : Sn-Ag over Nickel Plating
Eyelet	Brass/Nickel Plating

17JE-13250-37-FA

NO.OF.CONTACTS
09, 15, 25, 37

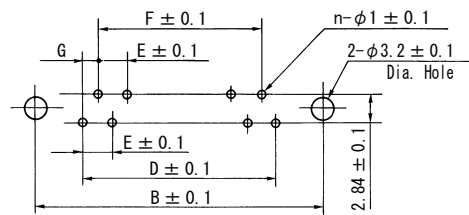
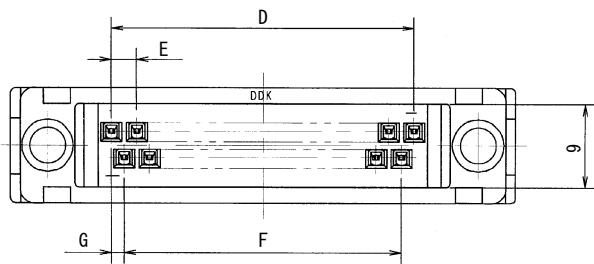
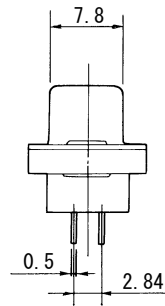
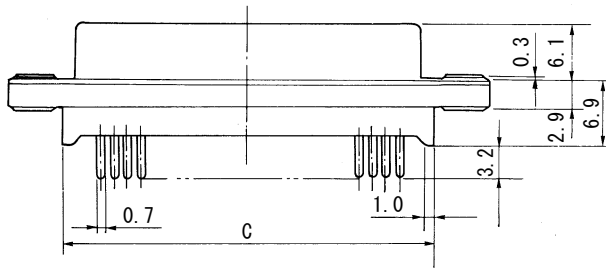
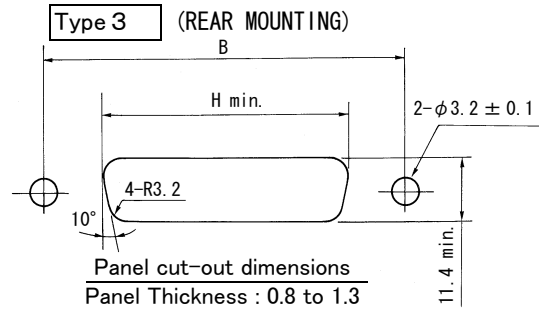
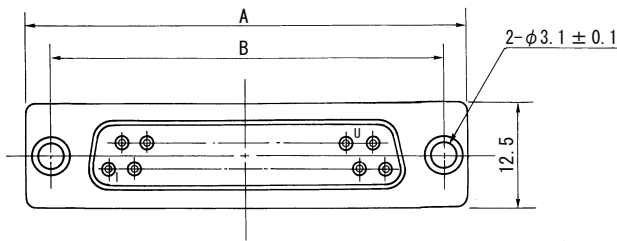

P. C. B. Mounting Dimensions
(REFERENCE)

P/N	A	B	C	D	E	F	G	H
17JE-13090-37-FA	30.8	24.99	18.99	10.98	2.74	8.22	1.37	20.5
17JE-13150-37-FA	39.1	33.32	27.32	19.20	2.74	16.44	1.37	28.8
17JE-13250-37-FA	53.0	47.04	41.04	33.12	2.76	30.36	1.38	42.5
17JE-13370-37-FA	69.3	63.50	57.50	49.68	2.76	46.92	1.38	59.1

G
17JE

17JE Series

Unit : mm

17JE-13250-37(D2A)-FA

NO.OF.CONTACTS
09, 15, 25, 37

DEVIATION
With Locking Device and Pan head Screw

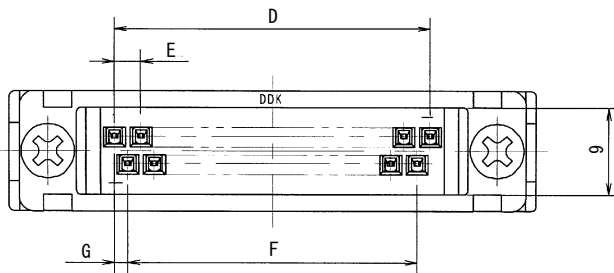
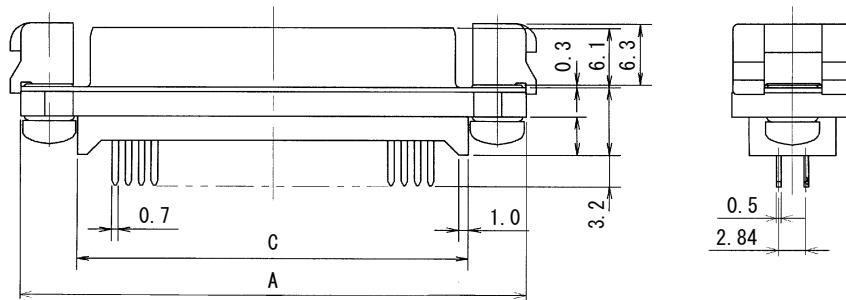
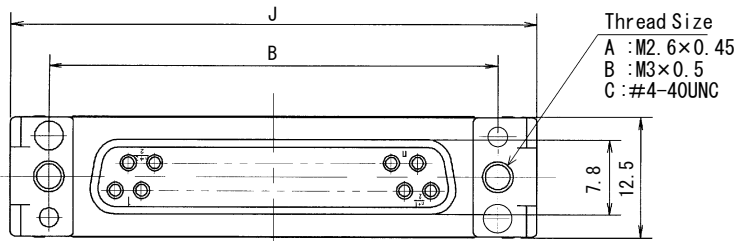

Type 1

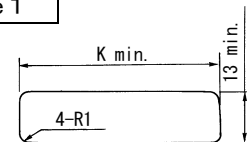

* Connector cannot be fixed on panel.

G
17JE

No.of Contacts	A	B	C	D	E	F	G	J	K
09	30.8	24.99	18.99	10.98	2.74	8.22	1.37	33.09	34.09
15	39.1	33.32	27.32	19.20	2.74	16.44	1.37	41.42	42.42
25	53.0	47.04	41.04	33.12	2.76	30.36	1.38	55.42	56.14
37	69.3	63.50	57.50	49.68	2.76	46.92	1.38	71.60	72.60

Mounting Straight DIP Type

(□ stands for type of engaging screw.)

Reference drawing of panel mounting hole

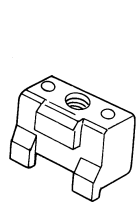

Stud
(17L-002□)

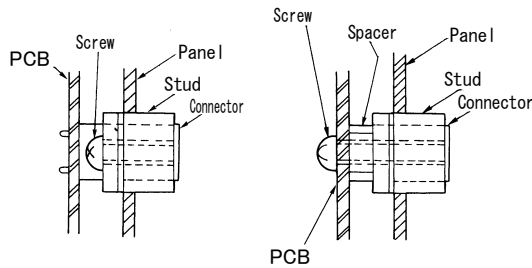

Type 1

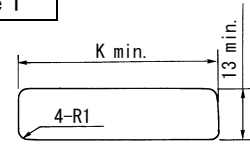

* Connector cannot be fixed on panel.

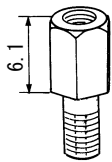

Jack Socket
(17L-003□1)

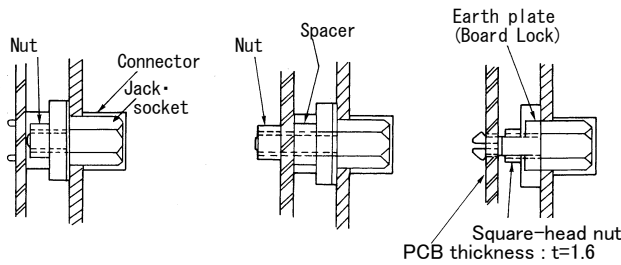

Type 2

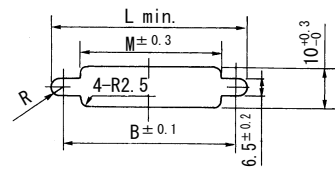

* Connector cannot be fixed on panel.

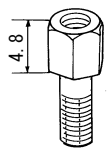

Jack Socket
(17L-003□3)

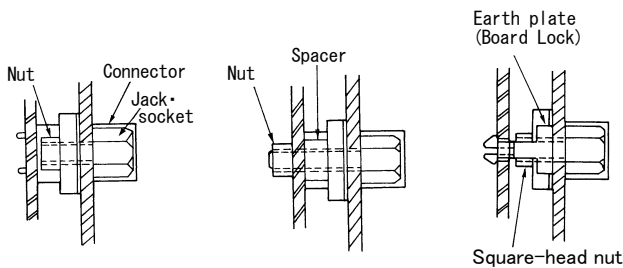

Type 3 (REAR MOUNTING)

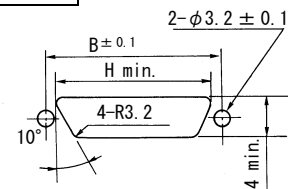

* Connector cannot be fixed on panel
(Panel thicknesses : 0.8 to 1.3)

□ : Jack socket thread size

A : M2.6 × 0.45 (Standard)

B : M3 × 0.5

C : #4-40UNC

No. of Contacts	B	H	K	L	M
9	24.99	20.5	34.09	31.0	18.5
15	33.32	28.8	42.42	39.3	26.8
25	47.04	42.5	56.14	53.2	40.5
37	63.50	59.1	72.60	69.5	57.0

List of Straight Type Deviations

(Shows combinations of ground tab/spacers and stud/jack sockets).

* "Equipped with" as used here means that connector has an accessory built in.

"Bundled (not built in)" as used here means that connector is supplied with an accessory not built in but bundled with it

		17JE-13□□0-37-FA 17JE-23□□0-37-FA		
Designations of Ground Tab and Spacer	Stud Jack Socket Designation		17J-011-FA Board Lock	57D-149-6A Spacer
Type1 Type not fastened to panel from both sides 	17L-002□ 	With locking device and pan head screw and 17L-002□ 17JE-13□□0-37(D2□)-FA		
Type2 Type not fastened to panel from both sides 	17L-003□1 	Equipped With M3 hexagon nut and 17L-003□1 17JE-13□□0-37(D3□)-FA	With M3 hexagon nut and 17L-003□1 17JE-13□□0-37(D23□)-FA	
	17L-003□2-CF 			Equipped With M3 hexagon nut and 17L-003□2-CF 17JE-13□□0-37(D28□)-CA
	17L-003□4-CF 			Equipped With M3 hexagon nut and 17L-003□4-CF 17JE-13□□0-37(D16□)-CA
Type3 Type fastened to panel from both sides (panel thickness : 1.3 max.) 	17L-003□3 	With Jack Sockets and hexagon nut 17L-003□3 17JE-13□□0-37(D4□)-FA Equipped With M3 hexagon nut and 17L-003□3 17JE-13□□0-37(D31□)-FA With Jack Sockets and 17L-003□3 17JE-13□□0-37(D36□)-FA		
	17L-003□6-CF 			Equipped With M3 hexagon nut and 17L-003□6-CF 17JE-13□□0-37(D71□)-CA With Jack Sockets and 17L-003□6-CF 17JE-13□□0-37(D30□)-CA

Stands for on combination.
 is recommended.
 stands for type of engaging screw.
 A :M2.6 × 0.45(Standard)
 B :M3 × 0.5
 C :#4-40UNC

G
 17JE