

## Ceramic Singlelayer Feed-Through Capacitors 400 V<sub>DC</sub>

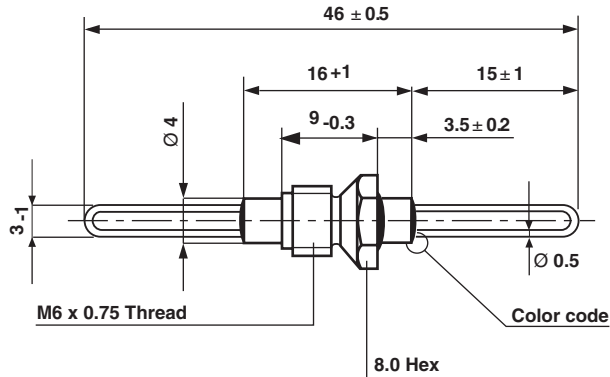

\* Dimensions in mm

### DIRECT CURRENT I<sub>DC</sub>:

8 A

### MAXIMUM PERMISSIBLE TORQUE:

0.8 Nm (clearance hole mounting)

0.5 Nm (threaded hole mounting)

### PERMISSIBLE POWER LOSS:

220 mW

### MARKING:

Capacitance value, Tolerance letter,  
Ceramic dielectric color code

### MOUNTING HARDWARE:

A threaded nut (8.0 HEX) is supplied in bulk

### DESIGN:

Feed-through capacitor, threaded type

### RATED VOLTAGE U<sub>R</sub>:

400 V<sub>DC</sub> (175 V<sub>RMS</sub>)

### DIELECTRIC STRENGTH BETWEEN LEADS:

1250 V<sub>DC</sub> 1 s

### DISSIPATION FACTOR tan δ:

Ceramic Class 1: see General Information

Ceramic Class 2:  $\leq 25 \cdot 10^{-3}$

### INSULATION RESISTANCE R<sub>is</sub>:

Ceramic Class 1:  $\geq 1 \cdot 10^{10} \Omega$

Ceramic Class 2:  $\geq 5 \cdot 10^9 \Omega$

### CATEGORY TEMPERATURE RANGE θ<sub>A</sub>:

Ceramic Class 1: (- 55 to + 125) °C

Ceramic Class 2: (- 25 to + 85) °C

### CLIMATIC TESTING CLASS ACC. TO EN 60068-1:

40 / 085 / 21

### PERMISSIBLE REACTIVE POWER:

8.8 VAR (Class 2), 150 VAR (Class 1B ,1F)

CLASS	CERAMIC DIELECTRIC	CAPACITANCE VALUE (pF)	TOLERANCE
1B	P 100	25	± 20 %
	N 150	50	
	N 750	250	
1F	N 1500	400	
2	R 700	500	- 20 + 50 %
		1000	
	R 2000	2500	
	R 4000	5000	

• other capacitance values are available on request

### ORDERING INFORMATION

DvML 0416

400 V<sub>DC</sub>

5000 pF

- 20 + 50 %

R 4000



## Disclaimer

All product specifications and data are subject to change without notice.

Vishay Intertechnology, Inc., its affiliates, agents, and employees, and all persons acting on its or their behalf (collectively, "Vishay"), disclaim any and all liability for any errors, inaccuracies or incompleteness contained herein or in any other disclosure relating to any product.

Vishay disclaims any and all liability arising out of the use or application of any product described herein or of any information provided herein to the maximum extent permitted by law. The product specifications do not expand or otherwise modify Vishay's terms and conditions of purchase, including but not limited to the warranty expressed therein, which apply to these products.

No license, express or implied, by estoppel or otherwise, to any intellectual property rights is granted by this document or by any conduct of Vishay.

The products shown herein are not designed for use in medical, life-saving, or life-sustaining applications unless otherwise expressly indicated. Customers using or selling Vishay products not expressly indicated for use in such applications do so entirely at their own risk and agree to fully indemnify Vishay for any damages arising or resulting from such use or sale. Please contact authorized Vishay personnel to obtain written terms and conditions regarding products designed for such applications.

Product names and markings noted herein may be trademarks of their respective owners.