

HD151TS201AT

Mother Board Clock Generator
for Intel P4 Chipset
Banias and Dothan processor / ODEM and
MONTARA–GM chip set

REJ03D0085–0100Z
Preliminary
Rev.1.00
Oct.21.2003

Description

The HD151TS201AT is Intel CK408 type high-performance, low-skew, low-jitter, PC motherboard Clock generator. It is specifically designed for Intel Pentium[®]4 chipset.
Banias and Dothan processor / ODEM and MONTARA–GM chip set

Features

- 3 differential pairs of current mode control CPU clock
- 7 PCI clocks and 3 PCIF clocks @3.3V, 33.3MHz typ.
- 1 copy of 48MHz for USB @3.3V
- 1 copy of 48MHz for DOT @3.3V
- 6 copies of 3V66 clock @3.3V,66.6MHz
- 1 copy of VCH@3.3V, 48MHz
- Power save and clock stop function.
- I²C[™] serial port programming
- Programmable Clock Control (Spread Spectrum Percentage, Clock Output Skew, Slew Rate)
- 56pin TSSOP (244 mils)
- Ordering Information

Part Name	Package Type	Package Code	Package Abbreviation	Taping Abbreviation (Quantity)
HD151TS201ATEL	TSSOP-56 pin	—	AT	EL (1,000 pcs / Reel)

Note: Please consult the sales office for the above package availability.

Note: I²C is a trademark of Philips Corporation.
Pentium is registered trademark of Intel Corporation

Key Specifications

- Supply Voltages: VDD = 3.0 V to 3.475 V
- CPU Clock cycle to cycle jitter = |150 ps|
- CPU clock group Skew = 100 ps
- 3V66 clock group Skew = 250 ps max
- PCI clock group Skew = 500 ps max

EOL announced Product

Pin Arrangement

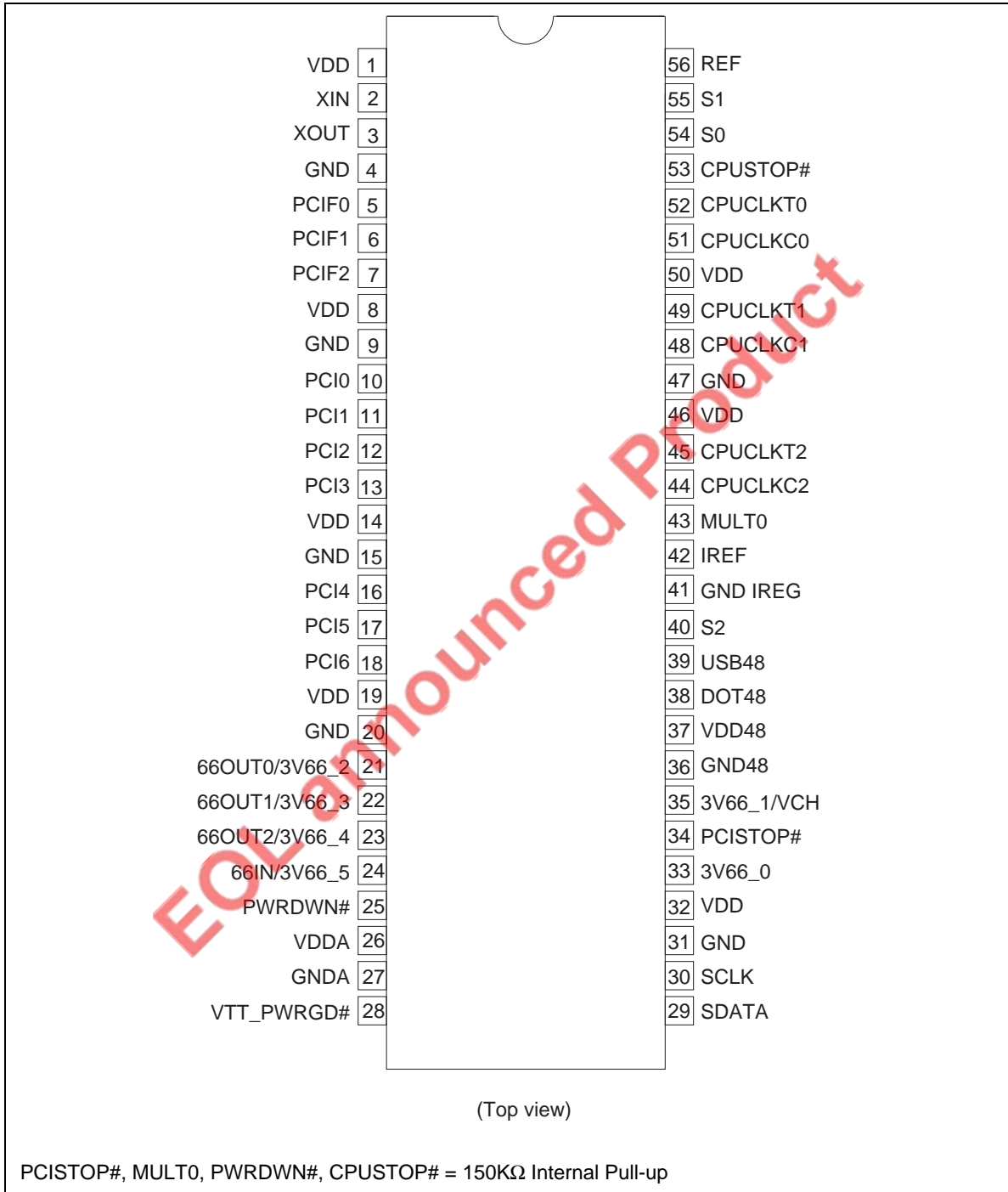

Block Diagram

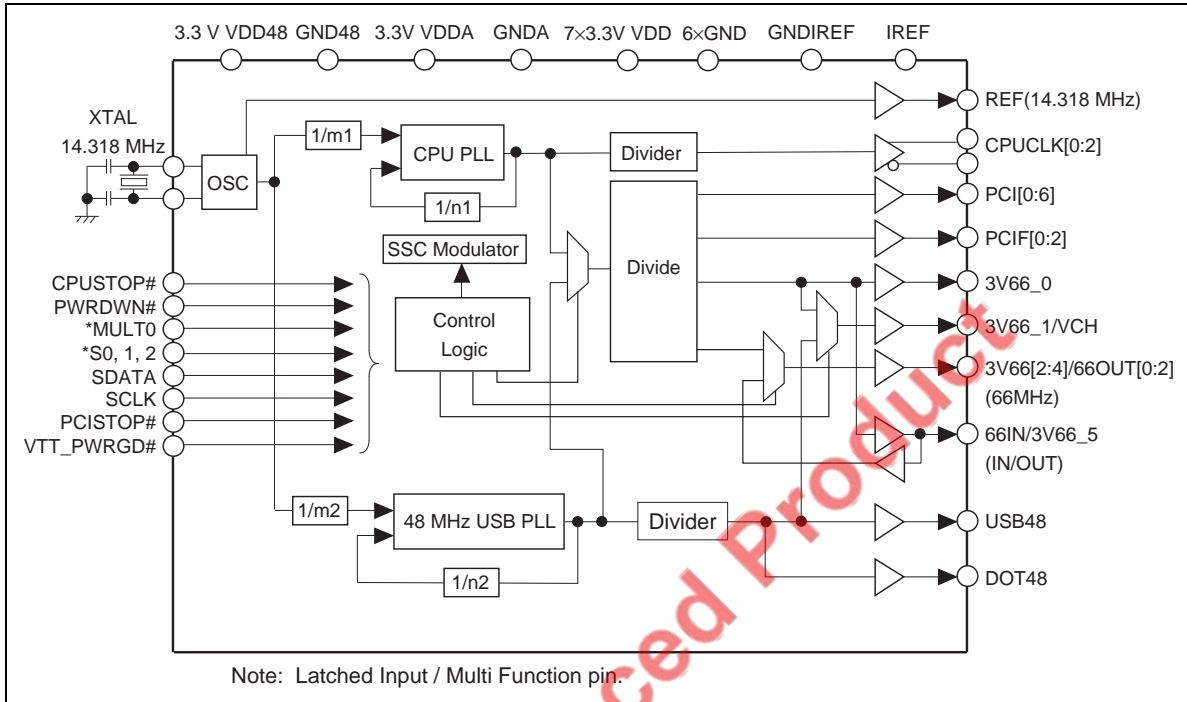

Table1 Clock Frequency Function Table & I²C

Byte8 (bit1, 2, 3, 4, 5)

	Bit5	Bit4	Bit3	Bit2	Bit1	CPU	3V66	PCI
0	0	0	0	0	0	66.67	66.67	33.33
1	0	0	0	0	1	100	66.67	33.33
2	0	0	0	1	0	200	66.67	33.33
3	0	0	0	1	1	133.33	66.67	33.33
4	0	0	1	0	0	150	50	25
5	0	0	1	0	1	166.67	55.56	27.78
6	0	0	1	1	0	150	66.67	33.33
7	0	0	1	1	1	166.67	66.67	33.33

EOL announced Product

Table2 Hardware Clock Frequency Table (MHz)

S2	S1	S0	CPU	3V66	66OUT[2:0] 3V66[4:0]	66IN 3V66_5	PCI	Note
0	0	0	66.67	66.67	66.67	66.67	33.33	Un-Buff Mode
0	0	1	100	66.67	66.67	66.67	33.33	Un-Buff Mode
0	1	0	200	66.67	66.67	66.67	33.33	Un-Buff Mode
0	1	1	133.33	66.67	66.67	66.67	33.33	Un-Buff Mode
1	0	0	66.67	66.67	66IN	66IN	66MHzIN/2	Buff Mode
1	0	1	100	66.67	66IN	66IN	66MHzIN/2	Buff Mode
1	1	0	200	66.67	66IN	66IN	66MHzIN/2	Buff Mode
1	1	1	133.33	66.67	66IN	66IN	66MHzIN/2	Buff Mode
Mid	0	0	Hi-Z	Hi-Z	Hi-Z	Hi-Z	Hi-Z	Tristate Mode
Mid	0	1	TCLK/2	TCLK/4	TCLK/4	TCLK/4	TCLK/8	Test Mode
Mid	1	0	150	50	50	50	25	
Mid	1	1	166.67	55.5	55.5	55.5	27.7	

Note: TCLK is a test clock over driven on the XIN during test mode.

Table3 CPUCLK Outputs Specification

MULT0 (pin43)	Board Target Trace/Term Z	Reference R, Iref = VDD/(3Rr)	Output Current Ioh	Voh @Z
0	50 Ω	Rr=221 1% I_REF=5.00mA	4 x Iref	1.0V @50 Ω
1	50 Ω	Rr=475 1% I_REF=2.32mA	6 x Iref	0.7V @50 Ω

Table4 Clock Power Management Truth Table

Byte0/bit6	Byte1/bit6	PWRDWN#	CPUSTOP#	*CPU Stoppable	*CPU Free Running
0	0	1	1	Run	Run
0	0	1	0	Iref*6	Run
0	0	0	1	Iref*2	Iref*2
0	0	0	0	Iref*2	Iref*2
0	1	1	1	Run	Run
0	1	1	0	Hi-Z	Run
0	1	0	1	Hi-Z	Iref*2
0	1	0	0	Hi-Z	Iref*2
1	0	1	1	Run	Run
1	0	1	0	Iref*6	Run
1	0	0	1	Hi-Z	Hi-Z
1	0	0	0	Hi-Z	Hi-Z
1	1	1	1	Run	Run
1	1	1	0	Hi-Z	Run
1	1	0	1	Hi-Z	Hi-Z
1	1	0	0	Hi-Z	Hi-Z

Note: CPURT&C State are controlled by Byte1 (bit3,4,5)

Table5 PCISTOP# I²C control Truth Table

PCISTOP# (pin34)	Byte0/bit3 Write bit	Byte0/bit3 Read bit (Internal status)
0	0	0
0	1	0
1	0	0
1	1	1

Table6 S2 pin Three Level Input

Logic Level	Min Voltage	Max Voltage
0 (Low)	—	0.8 V
Mid	1.0 V	1.8 V
1 (High)	2.0 V	—

I²C Controlled Register Bit Map

Byte0 Control Register

Bit	Description	Contents	Default
7	Spread spectrum Enable	"1" = SSC ON "0" = SSC OFF	0
6	CPUCLK Power down mode setting. See Table4.	See Table4	0
5	VCH (pin35) Select 66 MHZ or 48 MHZ	"1" = 48 MHZ "0" = 66 MHZ	0
4	CPUSTOP# status register	CPUSTOP# Reflects the current value of external CPUSTOP# (pin53). This bit is read only.	1
3	PCISTOP# Selection. See Table5	Reflects the current value of the internal PCISTOP# function when read. Internally PCISTOP# is a logical AND function of the internal SM Bus registers bit and the external PCISTOP# (pin34).	1
2	Reflects the value of the S2 (pin40)	Frequency selects bit2, reflects the value of S2 (pin40). This bit is read only.	X
1	Reflects the value of the S1 (pin55)	Frequency selects bit1, reflects the value of S1 (pin55). This bit is read only.	X
0	Reflects the value of the S0(pin54)	Frequency selects bit0, reflects the value of S0 (pin54). This bit is read only.	X

Byte1 Control Register

Bit	Description	Contents	Default
7	MULT0 (pin43) Value	MULT0 value. This bit is read only.	X
6	CPUCLK Power down mode setting. See Table4.	See Table4	0
5	Control of CPU2 with CPUSTOP#	"1" = Free running	0
4	Control of CPU1 with CPUSTOP#	"0" = Not free running.	0
3	Control of CPU0 with CPUSTOP#	When this bit is "0", CPUT/C outputs are affected by CPUSTOP# pin.	0
2	CPUT2/C2 Enable register	"1" = Enabled	1
1	CPUT1/C1 Enable register	"0" = Disabled	1
0	CPUT0/C0 Enable register	(CPUT stops "High" & CPUC stops "Low")	1

I²C Controlled Register Bit Map (cont.)

Byte2 PCI clock enable Register

Bit	Description	Contents	Default
7	(Reserved)		0
6	PCI6 Enable register	"1" = Enabled	1
5	PCI5 Enable register	"0" = Disabled	1
4	PCI4 Enable register	(Each PCI clock stops "Low")	1
3	PCI3 Enable register		1
2	PCI2 Enable register		1
1	PCI1 Enable register		1
0	PCI0 Enable register		1

Byte3 PCIF & USB, DOT enable Register

Bit	Description	Contents	Default
7	DOT output enable	1 = Enable, 0 = Disable (DC Low fixed)	1
6	USB output enable	1 = Enable, 0 = Disable (DC Low fixed)	1
5	Control of PCIF2 with PCISTOP#	"1" = Not Free running.	0
4	Control of PCIF1 with PCISTOP#	When this bit is "1", PCIF outputs are stopped by PCISTOP# pin.	0
3	Control of PCIF0 with PCISTOP#	"0" = Free running.	0
2	PCIF2 output enable	1 = Enable, 0 = Disable (DC Low fixed)	1
1	PCIF1 output enable	1 = Enable, 0 = Disable (DC Low fixed)	1
0	PCIF0 output enable	1 = Enable, 0 = Disable (DC Low fixed)	1

Byte4 66OUT, 3V66 Enable Register

Bit	Description	Contents	Default
7	Reserved		0
6	Reserved		0
5	3V66_0 Enable	1 = Enable, 0 = Disable (DC Low fixed)	1
4	3V66_1/VCH Enable	1 = Enable, 0 = Disable (DC Low fixed)	1
3	3V66_5 Enable	1 = Enable, 0 = Disable (DC Low fixed)	1
2	66OUT2/3V66_4 Enable	1 = Enable, 0 = Disable (DC Low fixed)	1
1	66OUT1/3V66_3 Enable	1 = Enable, 0 = Disable (DC Low fixed)	1
0	66OUT0/3V66_2 Enable	1 = Enable, 0 = Disable (DC Low fixed)	1

I²C Controlled Register Bit Map (cont.)

Byte5 Control Register

Bit	Description	Contents	Default
7	Reserved		0
6	Reserved		0
5	66IN to 66OUT [2:0] delay bit1		0
4	66IN to 66OUT[2:0] delay bit0		0
3	DOT Slew Rate Control bit1	00 = Default 01 = Fast1	0
2	DOT Slew Rate Control bit0	10 = Fast2 11 = Slow1	0
1	USB Slew Rate Control bit1	00 = Default 01 = Fast1	0
0	USB Slew Rate Control bit0	10 = Fast2 11 = Slow1	0

Byte6 Vendor ID Register

Bit	Description	Contents	Default
7	Revision Code		0
6			0
5			0
4			1
3	Vendor ID Register	Renesas = "1111"	1
2			1
1			1
0			1

Note: This register is read only register. Don't write any data.

Byte7 Byte Count Read Back Register

Bit	Description	Contents	Default
7	Byte Count setting bit7	Writing to this register will configure byte.	0
6	Byte Count setting bit6	Count and how many bytes will be read back.	0
5	Byte Count setting bit5	Default is 17hex = 23 bytes.	0
4	Byte Count setting bit4		1
3	Byte Count setting bit3		0
2	Byte Count setting bit2		1
1	Byte Count setting bit1		1
0	Byte Count setting bit0		1

I²C Controlled Register Bit Map (cont.)

Byte8 Clock Frequency Control Register

Bit	Description	Contents	Default
7	Reserved		X
6	Reserved		X
5	Reserved		0
4	Reserved		0
3	Clock Freq. Control bit2	See Table1	0
2	Clock Freq. Control bit1		0
1	Clock Freq. Control bit0		0
0	Freq. Select Mode bit	0 = Freq. is selected by latched input S2:0 1 = Freq. is selected by I ² C Byte8 bit5:1	0

Byte9 Control Register

Bit	Description	Contents	Default
7	Reserved		0
6	Reserved		0
5	Reserved		0
4	Reserved		0
3	Spread Spectrum Control bit	0 = -0.5% (Default) 1 = -1.0%	0
2	3V66 & PCI Clock PLL select bit	"0" = CPU PLL "1" = USB PLL When this bit set to "1", 3V66 & PCI clocks will be supply from USB PLL. Not depended on CPU PLL.	0
1	PLL N Divider Control bit9	PLL N Divider Control bit9	0
0	PLL N Divider Control bit8	PLL N Divider Control bit8	0

Note: Byte9 [1:0], Byte10 and Byte11 must be written together (at writing Byte11) in every case.

I²C Controlled Register Bit Map (cont.)

Byte10 PLL N Divider Ratio Control Register

Bit	Description	Contents	Default
7	PLL N Divider Control bit7	PLL N Divider Control bit7	X
6	PLL N Divider Control bit6	PLL N Divider Control bit6	X
5	PLL N Divider Control bit5	PLL N Divider Control bit5	X
4	PLL N Divider Control bit4	PLL N Divider Control bit4	X
3	PLL N Divider Control bit3	PLL N Divider Control bit3	X
2	PLL N Divider Control bit2	PLL N Divider Control bit2	X
1	PLL N Divider Control bit1	PLL N Divider Control bit1	X
0	PLL N Divider Control bit0	PLL N Divider Control bit0	X

Note: The default N value will be reflected in S [2:0] or Byte8 bit[5:1] frequency setting value. Byte9 [1:0], Byte10 and Byte11 must be written together (at writing Byte11) in every case.

Byte11 PLL M Divider Ratio Control Register

Bit	Description	Contents	Default
7	N & M divider enable bit	0: N & M value will be determined by S [2:0] or Byte8 bit[5:1]. 1: N & M value will be determined by Byte9,10,11.	0
6	PLL M Divider Control bit6	PLL M Divider Control bit6	X
5	PLL M Divider Control bit5	PLL M Divider Control bit5	X
4	PLL M Divider Control bit4	PLL M Divider Control bit4	X
3	PLL M Divider Control bit3	PLL M Divider Control bit3	X
2	PLL M Divider Control bit2	PLL M Divider Control bit2	X
1	PLL M Divider Control bit1	PLL M Divider Control bit1	X
0	PLL M Divider Control bit0	PLL M Divider Control bit0	X

Note: The default M value will be reflected in S [2:0] or Byte8 bit[5:1] frequency setting value. Byte9 [1:0], Byte10 and Byte11 must be written together (at writing Byte11) in every case.

I²C Controlled Register Bit Map (cont.)

Byte12 Clock Outputs Divider Control Register

Bit	Description	Contents	Default
7	Reserved		0
6	Reserved		0
5	Reserved		0
4	Reserved		0
3	Reserved		0
2	Reserved		0
1	Reserved		0
0	Reserved		0

Byte13 Clock Outputs Divider Control Register

Bit	Description	Contents	Default
7	PCISTOP# pin Enable	0 = Enable, 1 = Disable	0
6	CPUSTOP# pin Enable	0 = Enable, 1 = Disable	0
5	PWRDWN# pin Enable	0 = Enable, 1 = Disable	0
4	Reserved		0
3	Reserved		0
2	Reserved		0
1	Reserved		0
0	Reserved		0

Note: Byte 12 & 13 must be written together in every case.

I²C Controlled Register Bit Map (cont.)

Byte14 Control Register

Bit	Description	Contents	Default
7	Reserved		0
6	DOT Clock Invert	0=Normal, 1=Inverted	0
5	USB clock Invert	0=Normal, 1=Inverted	0
4	VCH clock Invert	0=Normal, 1=Inverted	0
3	PCI clock Invert	0=Normal, 1=Inverted	0
2	66OUT clock Invert	0=Normal, 1=Inverted	0
1	3V66 clock Invert	0=Normal, 1=Inverted	0
0	CPU clock Invert	0=Normal, 1=Inverted	0

Byte15 Control Register

Bit	Description	Contents	Default
7	REF clock enable	0 = Enable, 1 = Disable	0
6	Control of PCI6 with PCISTOP#	"0" = Not Free running	0
5	Control of PCI5 with PCISTOP#	When this bit is "0", PCI outputs are stopped by PCISTOP# pin.	0
4	Control of PCI4 with PCISTOP#	"1" = Free running.	0
3	Control of PCI3 with PCISTOP#		0
2	Control of PCI2 with PCISTOP#		0
1	Control of PCI1 with PCISTOP#		0
0	Control of PCI0 with PCISTOP#		0

Byte16 CPU Skew Control Register

Bit	Description	Contents	Default
7	(Reserved)		0
6	(Reserved)		0
5	CPU clock skew controlbit5	00 : Delay 0ps 10 : Ahead 500ps	0
4	CPU clock skew controlbit4	01 : Delay 250ps 11 : Ahead 250ps	0
3	CPU clock skew controlbit3	0100 : Delay 0ps	0
2	CPU clock skew controlbit2	0101 : Delay 500ps 0011 : Ahead 500ps	1
		0110 : Delay 1000ps 0010 : Ahead 1000ps	
1	CPU clock skew controlbit1	0111 : Delay 1500ps 0001 : Ahead 1500ps	0
0	CPU clock skew controlbit0	1000 : Delay 2000ps 0000 : Ahead 2000ps	0
		Don't set 1001 to 1111	

I²C Controlled Register Bit Map (cont.)

Byte17 3V66 Skew Control Register

Bit	Description	Contents	Default
7	(Reserved)		0
6	(Reserved)		0
5	3V66 clock skew controlbit5	00 : Delay 0ps 11 : Ahead 500ps	0
4	3V66 clock skew controlbit4	01 : Delay 250ps 11 : Ahead 250ps	0
3	3V66 clock skew controlbit3	0100 : Delay 0ps	0
2	3V66 clock skew controlbit2	0101 : Delay 500ps 0011 : Ahead 500ps 0110 : Delay 1000ps 0010 : Ahead 1000ps	0
1	3V66 clock skew controlbit1	0111 : Delay 1500ps 0001 : Ahead 1500ps	1
0	3V66 clock skew controlbit0	1000 : Delay 2000ps 0000 : Ahead 2000ps Don't set 1001 to 1111	0

Byte18 PCI Skew Control Register 1

Bit	Description	Contents	Default
7	(Reserved)		0
6	(Reserved)		0
5	PCI clock skew controlbit5	00 : Delay 0ps 10 : Ahead 500ps	0
4	PCI clock skew controlbit4	01 : Delay 250ps 11 : Ahead 250ps	0
3	PCI clock skew controlbit3	0100 : Delay 0ps	0
2	PCI clock skew controlbit2	0101 : Delay 500ps 0011 : Ahead 500ps 0110 : Delay 1000ps 0010 : Ahead 1000ps	1
1	PCI clock skew controlbit1	0111 : Delay 1500ps 0001 : Ahead 1500ps	1
0	PCI clock skew controlbit0	1000 : Delay 2000ps 0000 : Ahead 2000ps Don't set 1001 to 1111	0

Byte19 PCI Skew Control Register 2

Bit	Description	Contents	Default
7	(Reserved)		0
6	PCI_F2 skew Early or Late	"0" = Early	0
5	PCI_F1 skew Early or Late	"1" = Late	0
4	PCI_F0 skew Early or Late		0
3	PCI clock skew controlbit3	0100 : Delay 0ps	0
2	PCI clock skew controlbit2	0101 : Delay 500ps 0011 : Ahead 500ps 0110 : Delay 1000ps 0010 : Ahead 1000ps	1
1	PCI clock skew controlbit1	0111 : Delay 1500ps 0001 : Ahead 1500ps	0
0	PCI clock skew controlbit0	1000 : Delay 2000ps 0000 : Ahead 2000ps Don't set 1001 to 1111	0

I²C Controlled Register Bit Map (cont.)

Byte20 PCI Skew Control Register 3

Bit	Description	Contents	Default
7	(Reserved)		0
6	PCI6 skew Early or Late	"0" = Early	0
5	PCI5 skew Early or Late	"1" = Late	0
4	PCI4 skew Early or Late		0
3	PCI3 skew Early or Late		0
2	PCI2 skew Early or Late		0
1	PCI1 skew Early or Late		0
0	PCI0 skew Early or Late		0

Byte21 Slew Rate Control Register

Bit	Description	Contents	Default
7	PCI clock slew rate controlbit1	00 : Normal 10 : ++	0
6	PCI clock slew rate controlbit0	01 : + 11 : -	0
5	PCIF clock slew rate controlbit1	00 : Normal 10 : ++	0
4	PCIF clock slew rate controlbit0	01 : + 11 : -	0
3	66OUT clock slew rate controlbit1	00 : Normal 10 : ++	0
2	66OUT clock slew rate controlbit0	01 : + 11 : -	0
1	3V66 clock slew rate controlbit1	00 : Normal 10 : ++	0
0	3V66 clock slew rate controlbit0	01 : + 11 : -	0

Byte22 Slew Rate Control Register

Bit	Description	Contents	Default
7	Reserved		1
6	Reserved		0
5	Reserved		1
4	Reserved		1
3	REF clock slew rate controlbit1	00 : Normal 10 : ++	0
2	REF clock slew rate controlbit0	01 : + 11 : -	0
1	VCH clock slew rate controlbit1	00 : Normal 10 : ++	0
0	VCH clock slew rate controlbit0	01 : + 11 : -	0

Absolute Maximum Ratings

Item	Symbol	Ratings	Unit	Conditions
Supply voltage	VDD	-0.5 to 4.6	V	
Input voltage	V _I	-0.5 to 4.6	V	
Output voltage * ¹	V _O	-0.5 to VDD +0.5	V	
Input clamp current	I _{IK}	-50	mA	V _I < 0
Output clamp current	I _{OK}	-50	mA	V _O < 0
Continuous output current	I _O	±50	mA	V _O = 0 to VDD
Maximum power dissipation at Ta = 55°C (in still air)		0.7	W	
Storage temperature	Tstg	-65 to +150	°C	

Notes: Stresses beyond those listed under “absolute maximum ratings” may cause permanent damage to the device. These are stress ratings only, and functional operation of the device at these or any other conditions beyond those indicated under “recommended operating conditions” is not implied. Exposure to absolute maximum rated conditions for extended periods may affect device reliability.

1. The input and output negative voltage ratings may be exceeded if the input and output clamp current ratings are observed.

Recommended Operating Conditions

Item	Symbol	Min	Typ	Max	Unit	Conditions
Supply voltage	VDD	3.00	3.3	3.465	V	
Supply voltage	VDDA	3.00	3.3	3.465	V	
DC input signal voltage		-0.3	—	VDD+0.3	V	
High level input voltage	V _{IH}	2.0	—	VDD+0.3	V	
Low level input voltage	V _{IL}	-0.3	—	0.8	V	
Operating temperature	Ta	0	—	85	°C	

Pin Descriptions

Pin name	No.	Type	Description
GND	4,9,15,20 31,36,41,47	Ground	GND pins
VDD	1,8,14,19 32,37,46,50	Power	Power supplies pins. Nominal 3.3 V.
VDDA	26	Power	Power supply for PLL core.
GNDA	27	Power	Power supply for PLL core.
CPUT[2:0]	45,49,52	OUTPUT	“True” clocks of differential pair CPUCLK. These pins are HCSL output.
CPUC[2:0]	44,48,51	OUTPUT	“Complementary” clocks of differential pair CPUCLK. These pins are HCSL output.
CPUSTOP#	53	INPUT	CPUCLK STOP pin. Active low input. When asserted low, CPUT [2:0] clocks are synchronously disabled in high state and CPUC [2:0] clocks are synchronously disabled in a low state. CPUSTOP# pin is 150 kΩ internal pulled-up.
PCIF[2:0]	7,6,5	OUTPUT	Free running PCI clock 3.3 V output. 33 MHz clocks divided from 3V66.
PCI[6:0]	18,17,16,13 12,11,10	OUTPUT	3.3 V PCI clock outputs. 33 MHz clocks divided from 3V66.
PCISTOP#	34	INPUT	PCICLK STOP pin. Active low input. When asserted low, PCI [6:0] clocks are synchronously disabled in low state. This pin does not effect PCIF [2:0] clocks outputs if they are programmed to be PCIF clocks via the device’s SM Bus interface. PCISTOP# pin is 150 kΩ internal pulled-up.
S1, S0	55,54	INPUT	Frequency selects input. See frequency table2 in page5.
S2	40	INPUT	Frequency selects input. See frequency table2 in page5. This pin is 3 level input.
VTT_PWRGD#	28	INPUT	Qualifying input that latches S [2:0] and MULT0. When this input is at a logic low, the S[2:0] and MULT0 are latched.

Pin Descriptions (cont.)

Pin name	No.	Type	Description
REF	56	OUTPUT	14.318MHz reference clock.
MULT0	43	INPUT	CPUCLK's output current setting. This pin is 150kΩ internal pull-up.
PWRDWN#	25	INPUT	Power down pin. All circuits will be powered down. (Output state of each output is shown in page Table.) Asynchronous active low input pin used to power down the device into low power state. The internal clocks are disabled and VCO and the crystal are stopped.
USB48	39	OUTPUT	3.3V 48 MHz USB clock output.
DOT48	38	OUTPUT	3.3V 48MHz DOT clock output.
XIN	2	INPUT	XTAL input.
XOUT	3	OUTPUT	XTAL output. Don't connect when an external clock is applied to XIN.
SDATA	29	INPUT/ OUTPUT	Data input/output for I ² C logic. This pin is internal pull-up to VDD by 150KΩ resistor.
SCLK	30	INPUT	Clock input for I ² C logic. This pin is internal pull-up to VDD by 150KΩ resistor.
IREF	42	IN	A precision resistor is attached to this pin which is connected to internal current reference. A resistor is connected between this pin and GNDIREF.
3V66_0	33	OUTPUT	3.3 V 66 MHz clock.
3V66_1/VCH	35	OUTPUT	3.3V clock output selectable with SM Bus byte0, bit5. When Byte0 bit5 is at logic"1", this pin is 48 MHz clock output. When Byte0 bit5 is at logic"0", this pin is 66 MHz clock output. Default is 66 MHz output.
66IN/3V66_5	24	IN/OUT	If S2 = 1, Input connection for 66OUT [2:0]. If S2 = 0, outputs fixed 66 MHz clock.
66OUT[2:0]/ 3V66[4:2]	23,22,21	OUTPUT	If S2 = 1, Buffered copies of 66IN. If S2=0, outputs fixed 66MHz clock.

DC Electrical Characteristics / Serial Input Port

Ta = 0°C to 85°C, VDD = 3.3 V

Item	Symbol	Min	typ* ¹	Max	Unit	Test Conditions
Input Low Voltage	V _{IL}	—	—	0.8	V	
Input High Voltage	V _{IH}	2.0	—	—	V	
Input Current	I _I	-50	—	+50	μA	V _I = 0 V or 3.465 V, VDD = 3.465 V
Input capacitance	C _I	—	10	—	pF	SDATA & SCLK* ²

Note: 1. For conditions shown as Min or Max, use the appropriate value specified under recommended operating conditions.
 2. Target of design, not 100% tested in production.

AC Electrical Characteristics / Serial Input port

Item	Symbol	Min	Typ	Max	Unit	Test Conditions
SCLK Frequency	F _{SCLK}	—	—	100	kHz	Normal Mode
Start Hold Time	t _{STHD}	4.0	—	—	μs	
SCLK Low Time	t _{LOW}	4.7	—	—	μs	
SCLK High Time	t _{HIGH}	4.0	—	—	μs	
Data Setup Time	t _{DSU}	250	—	—	ns	
Data Hold Time	t _{DHD}	300	—	—	ns	
Stop Setup Time	t _{TSU}	4.0	—	—	μs	
BUS Free Time between Stop & Start Condition	t _{SPF}	4.7	—	—	μs	

Note: Target of design, not 100% tested in production.

DC Electrical Characteristics CPUT/C Clock

Ta = 0°C to 85°C

Item	Symbol	Min	Typ * ¹	Max	Unit	Test Conditions
Output voltage	V _O	—	0.695	1.2	V	R _p = 49.9, VDD = 3.3 V
Output Current	I _O	—	I(nom)	—	mA	VDD = 3.3 V * ²
Output resistance		3000	—	—	Ω	V _O = 1.2 V

Note: 1. For conditions shown as Min or Max, use the appropriate value specified under recommended operating conditions
 2. I(nom) is output current(I_{oh}) shown in Page5 Table3.

AC Electrical Characteristics CPUT/C Clock (CPU at 0.7V Timing)

Ta = 0°C to 85°C, VDD = 3.3 V, C_L = 2 pF, R_s = 33.2 Ω, R_p = 49.9 Ω

Item	Symbol	Min	Typ	Max	Unit	Test Conditions
Cycle to cycle jitter* ¹	t _{CCS}	—	150	—	ps	
CPU Group Skew (CPU clock out to CPU clock out)	t _{skS}	—	100	—	ps	
Rise time	t _r	175	—	700	ps	V _O = 0.175 V to 0.525 V
Fall time	t _f	175	—	700	ps	V _O = 0.175 V to 0.525 V
Clock Duty Cycle		45	50	55	%	
CPU clock period (66)		—	15.075	—	ns	
CPU clock period (100)		—	10.25	—	ns	
CPU clock period (133)		—	7.5	—	ns	
CPU clock period (200)		—	4.975	—	ns	

Note: 1. Difference of cycle time between two adjoining cycles.

HD151TS201AT

DC Electrical Characteristics / 3V66 Clock (CK408 Type5 Buffer)

Ta = 0°C to 85°C, VDD = 3.3 V

Item	Symbol	Min	Typ *1	Max	Unit	Test Conditions
Output Voltage	V _{OH}	3.1	—	—	V	I _{OH} = -1 mA, VDD = 3.3 V
	V _{OL}	—	—	50	mV	I _{OL} = 1 mA, VDD = 3.3 V
Output Current	I _{OH}	—	—	-33	mA	V _{OH} = 1.0 V
	I _{OL}	30	—	—	mA	V _{OL} = 1.95 V

Note: 1. For conditions shown as Min or Max, use the appropriate value specified under recommended operating conditions.

AC Electrical Characteristics / 3V66 Clock

Ta = 0°C to 85°C, VDD = 3.3 V, C_L = 30 pF

Item	Symbol	Min	Typ	Max	Unit	Test Conditions	Notes
Cycle to cycle jitter	t _{CCS}	—	250	—	ps	Fig1	*1
3V66 Group Skew	t _{skS}	—	0	250	ps	Rising edge @1.5 V to 1.5 V Fig.2	
Slew rate	t _{SL}	1.0	—	4.0	V/ns		0.4V to 2.4V
Clock Duty Cycle		45	50	55	%		
3V66[5:0] leads 33 MHz PCI		1.5	—	3.5	ns	Un-Buffer Mode	

Note: 1. Difference of cycle time between two adjoining cycles.

DC Electrical Characteristics / PCI & PCIF Clock (CK408 Type5 Buffer)

Ta = 0°C to 85°C, VDD = 3.3 V

Item	Symbol	Min	Typ *1	Max	Unit	Test Conditions
Output Voltage	V _{OH}	3.1	—	—	V	I _{OH} = -1 mA, VDD = 3.3 V
	V _{OL}	—	—	50	mV	I _{OL} = 1 mA, VDD = 3.3 V
Output Current	I _{OH}	—	—	-33	mA	V _{OH} = 1.0 V
	I _{OL}	30	—	—	mA	V _{OL} = 1.95 V

Note: 1. For conditions shown as Min or Max, use the appropriate value specified under recommended operating conditions.

AC Electrical Characteristics / PCI & PCIF Clock

Ta = 0°C to 85°C, VDD = 3.3 V, C_L = 30 pF

Item	Symbol	Min	Typ	Max	Unit	Test Conditions	Notes
Cycle to cycle jitter	t _{CCS}	—	250	—	ps	Fig1	*1
PCI Group Skew	t _{skS}	—	0	500	ps	Rising edge @1.5V to 1.5V Fig.2	
Clock Period		—	20.8316	—	ns		
Slew rate	t _{SL}	1.0	—	4.0	V/ns		0.4 V to 2.4 V
Clock Duty Cycle		45	50	55	%		

Note: 1. Difference of cycle time between two adjoining cycles.

DC Electrical Characteristics / USB & VCH Clock (CK408 Type3A Buffer)

Ta = 0°C to 85°C, VDD = 3.3 V

Item	Symbol	Min	Typ *1	Max	Unit	Test Conditions
Output Voltage	V _{OH}	3.1	—	—	V	I _{OH} = -1 mA, VDD = 3.3 V
	V _{OL}	—	—	50	mV	I _{OL} = 1 mA, VDD = 3.3 V
Output Current	I _{OH}	—	—	-29	mA	V _{OH} = 1.0 V
	I _{OL}	29	—	—	mA	V _{OL} = 1.95 V

Note: 1. For conditions shown as Min or Max, use the appropriate value specified under recommended operating conditions.

AC Electrical Characteristics / USB & VCH Clock

Ta = 0°C to 85°C, VDD = 3.3 V, C_L = 20 pF

Item	Symbol	Min	Typ	Max	Unit	Test Conditions	Notes
Cycle to cycle jitter	t _{ccs}	—	350	—	ps	Fig1	*1
Clock Period		—	20.82985	—	ns		
Slew rate	t _{SL}	1.0	—	2.0	V/ns		0.4 V to 2.4 V
Clock Duty Cycle		45	50	55	%		

Note: 1. Difference of cycle time between two adjoining cycles.

EOL announced Product

DC Electrical Characteristics / DOT Clock (CK408 Type3B Buffer)

Ta = 0°C to 85°C, VDD = 3.3 V

Item	Symbol	Min	Typ *1	Max	Unit	Test Conditions
Output Voltage	V _{OH}	3.1	—	—	V	I _{OH} = -1 mA, VDD = 3.3 V
	V _{OL}	—	—	50	mV	I _{OL} = 1 mA, VDD = 3.3 V
Output Current	I _{OH}	—	—	-29	mA	V _{OH} = 1.0 V
	I _{OL}	29	—	—	mA	V _{OL} = 1.95 V

Note: 1. For conditions shown as Min or Max, use the appropriate value specified under recommended operating conditions.

AC Electrical Characteristics / DOT Clock

Ta = 0°C to 85°C, VDD = 3.3 V, C_L = 10 pF

Item	Symbol	Min	Typ	Max	Unit	Test Conditions	Notes
Cycle to cycle jitter	t _{ccs}	—	350	—	ps	Fig1	*1
Clock Period		—	20.82985	—	ns		
Slew rate	t _{SL}	2.0	—	4.0	V/ns		0.4 V to 2.4 V
Clock Duty Cycle		45	50	55	%		

Note: 1. Difference of cycle time between two adjoining cycles.

EOL announced Product

DC Electrical Characteristics / REF Clock (CK408 Type5 Buffer)

Ta = 0°C to 85°C, VDD = 3.3 V

Item	Symbol	Min	Typ *1	Max	Unit	Test Conditions
Output Voltage	V _{OH}	3.1	—	—	V	I _{OH} = -1 mA, VDD = 3.3 V
	V _{OL}	—	—	50	mV	I _{OL} = 1 mA, VDD = 3.3 V
Output Current	I _{OH}	—	—	-33	mA	V _{OH} = 1.0 V
	I _{OL}	30	—	—	mA	V _{OL} = 1.95 V

Note: 1. For conditions shown as Min or Max, use the appropriate value specified under recommended operating conditions.

AC Electrical Characteristics / REF Clock

Ta = 0°C to 85°C, VDD = 3.3 V, C_L = 30 pF

Item	Symbol	Min	Typ	Max	Unit	Test Conditions	Notes
Cycle to cycle jitter	t _{ccs}	—	1000	—	ps	Fig1	*1
Clock Period		—	69.8413	—	ns		
Slew Rate		1.0	—	4.0	V/ns		
Clock Duty Cycle		45	50	55	%		

Note: 1. Difference of cycle time between two adjoining cycles.

EOL announced Product

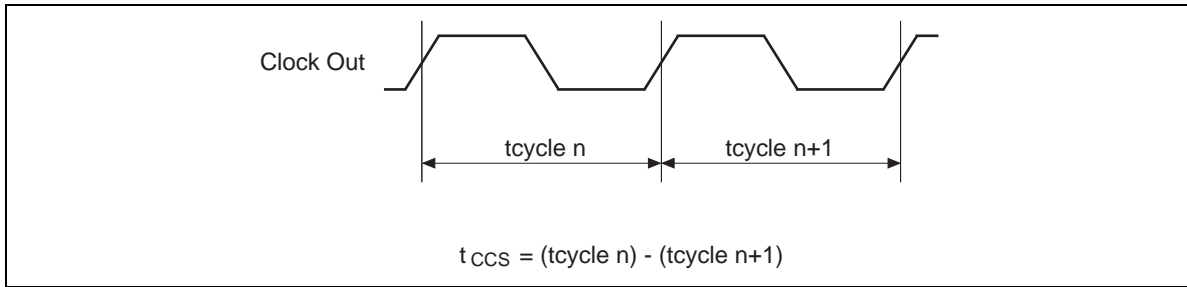

Figure1 Cycle to Cycle Jitter (3.3 V Single Ended Clock Output)

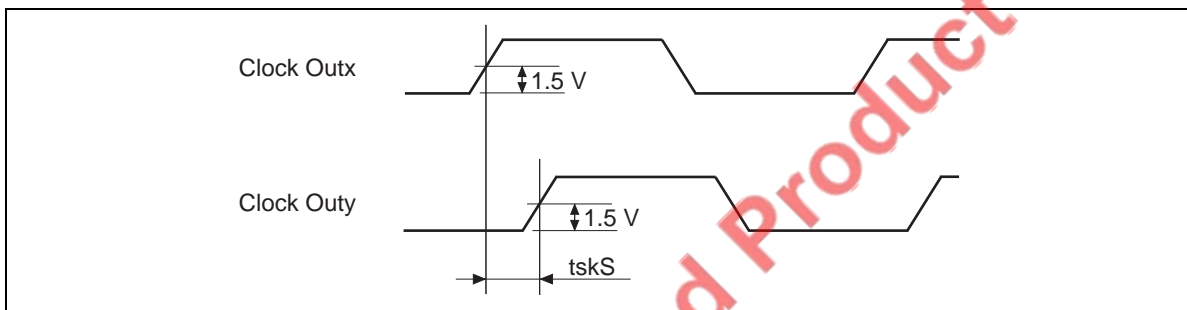

Figure2 Output Clock Skew (3.3 V Single Ended Clock Output)

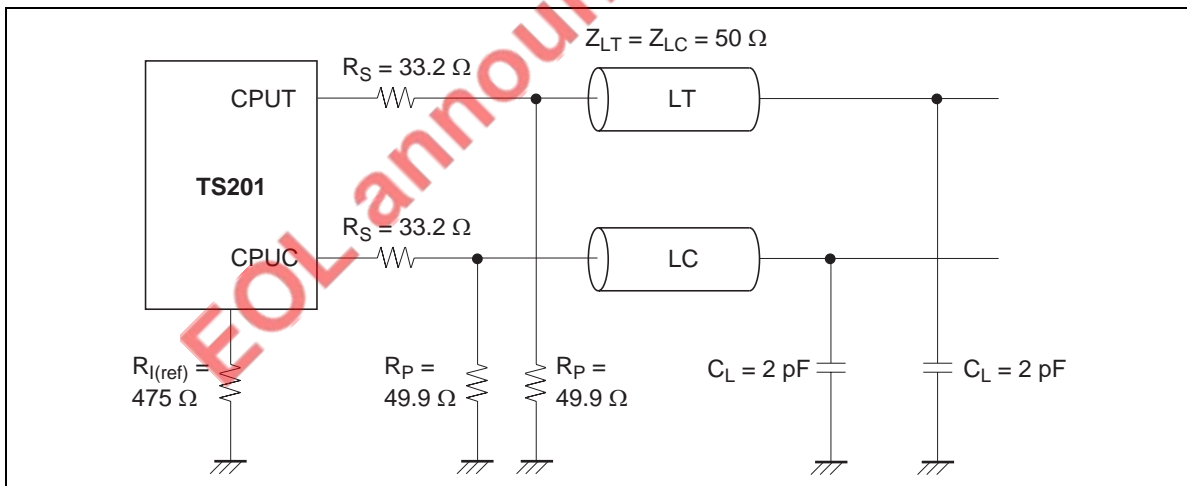
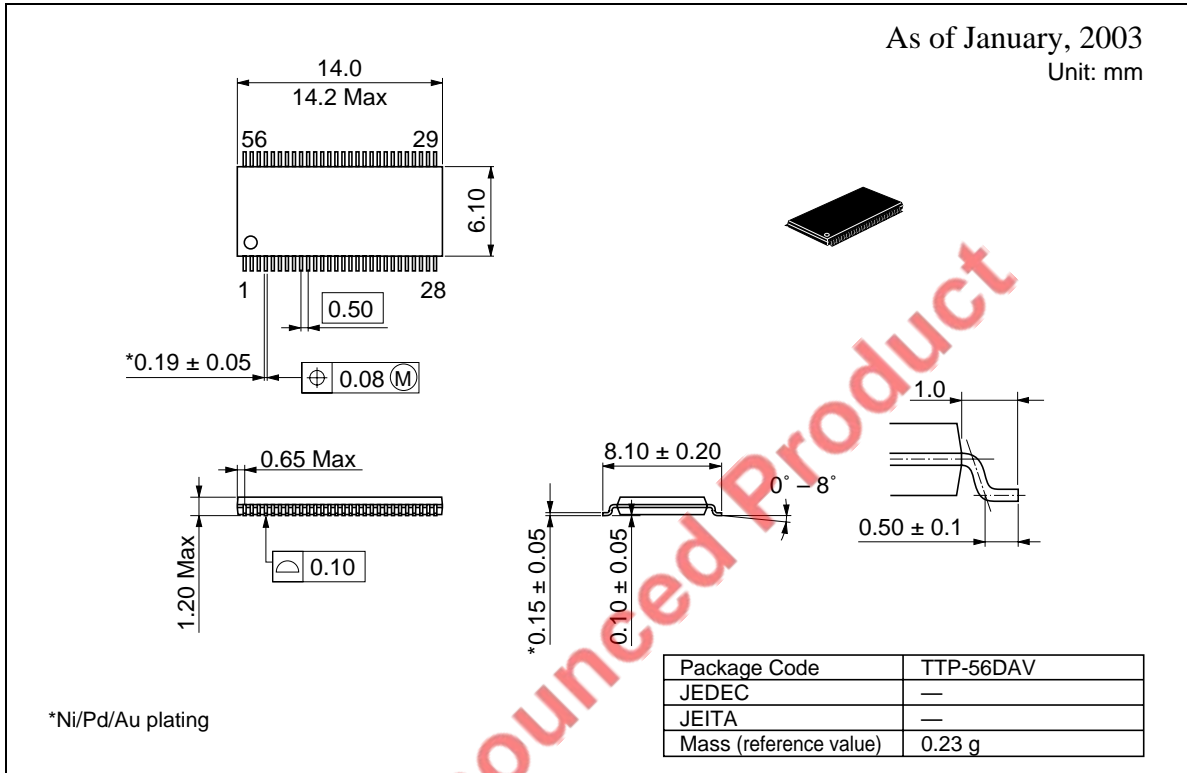

Figure3 Load Circuit for CPUT/C

Package Dimensions

• TSSOP-56



Renesas Technology Corp. Sales Strategic Planning Div. Nippon Bldg., 2-6-2, Ohte-machi, Chiyoda-ku, Tokyo 100-0004, Japan

Keep safety first in your circuit designs!

1. Renesas Technology Corp. puts the maximum effort into making semiconductor products better and more reliable, but there is always the possibility that trouble may occur with them. Trouble with semiconductors may lead to personal injury, fire or property damage.
Remember to give due consideration to safety when making your circuit designs, with appropriate measures such as (i) placement of substitutive, auxiliary circuits, (ii) use of nonflammable material or (iii) prevention against any malfunction or mishap.

Notes regarding these materials

1. These materials are intended as a reference to assist our customers in the selection of the Renesas Technology Corp. product best suited to the customer's application; they do not convey any license under any intellectual property rights, or any other rights, belonging to Renesas Technology Corp. or a third party.
2. Renesas Technology Corp. assumes no responsibility for any damage, or infringement of any third-party's rights, originating in the use of any product data, diagrams, charts, programs, algorithms, or circuit application examples contained in these materials.
3. All information contained in these materials, including product data, diagrams, charts, programs and algorithms represents information on products at the time of publication of these materials, and are subject to change by Renesas Technology Corp. without notice due to product improvements or other reasons. It is therefore recommended that customers contact Renesas Technology Corp. or an authorized Renesas Technology Corp. product distributor for the latest product information before purchasing a product listed herein.
The information described here may contain technical inaccuracies or typographical errors.
Renesas Technology Corp. assumes no responsibility for any damage, liability, or other loss rising from these inaccuracies or errors.
Please also pay attention to information published by Renesas Technology Corp. by various means, including the Renesas Technology Corp. Semiconductor home page (<http://www.renesas.com>).
4. When using any or all of the information contained in these materials, including product data, diagrams, charts, programs, and algorithms, please be sure to evaluate all information as a total system before making a final decision on the applicability of the information and products. Renesas Technology Corp. assumes no responsibility for any damage, liability or other loss resulting from the information contained herein.
5. Renesas Technology Corp. semiconductors are not designed or manufactured for use in a device or system that is used under circumstances in which human life is potentially at stake. Please contact Renesas Technology Corp. or an authorized Renesas Technology Corp. product distributor when considering the use of a product contained herein for any specific purposes, such as apparatus or systems for transportation, vehicular, medical, aerospace, nuclear, or undersea repeater use.
6. The prior written approval of Renesas Technology Corp. is necessary to reprint or reproduce in whole or in part these materials.
7. If these products or technologies are subject to the Japanese export control restrictions, they must be exported under a license from the Japanese government and cannot be imported into a country other than the approved destination.
Any diversion or reexport contrary to the export control laws and regulations of Japan and/or the country of destination is prohibited.
8. Please contact Renesas Technology Corp. for further details on these materials or the products contained therein.



RENESAS SALES OFFICES

<http://www.renesas.com>

Renesas Technology America, Inc.
450 Holger Way, San Jose, CA 95134-1368, U.S.A
Tel: <1> (408) 382-7500 Fax: <1> (408) 382-7501

Renesas Technology Europe Limited.
Dukes Meadow, Millboard Road, Bourne End, Buckinghamshire, SL8 5FH, United Kingdom
Tel: <44> (1628) 585 100, Fax: <44> (1628) 585 900

Renesas Technology Europe GmbH
Dornacher Str. 3, D-85622 Feldkirchen, Germany
Tel: <49> (89) 380 70 0, Fax: <49> (89) 929 30 11

Renesas Technology Hong Kong Ltd.
7/F., North Tower, World Finance Centre, Harbour City, Canton Road, Hong Kong
Tel: <852> 2265-6688, Fax: <852> 2375-6836

Renesas Technology Taiwan Co., Ltd.
FL 10, #99, Fu-Hsing N. Rd., Taipei, Taiwan
Tel: <886> (2) 2715-2888, Fax: <886> (2) 2713-2999

Renesas Technology (Shanghai) Co., Ltd.
26/F., Ruijin Building, No.205 Maoming Road (S), Shanghai 200020, China
Tel: <86> (21) 6472-1001, Fax: <86> (21) 6415-2952

Renesas Technology Singapore Pte. Ltd.
1, Harbour Front Avenue, #06-10, Keppel Bay Tower, Singapore 098632
Tel: <65> 6213-0200, Fax: <65> 6278-8001