

MS27470 Jam Nut Mount Hermetic Receptacle MIL-DTL-38999 Series I

How To Order: MS

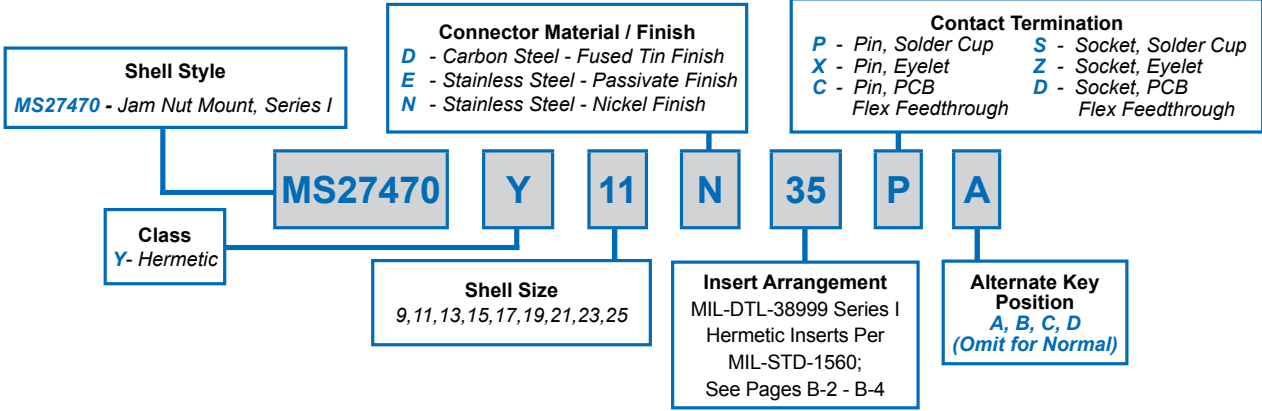

B

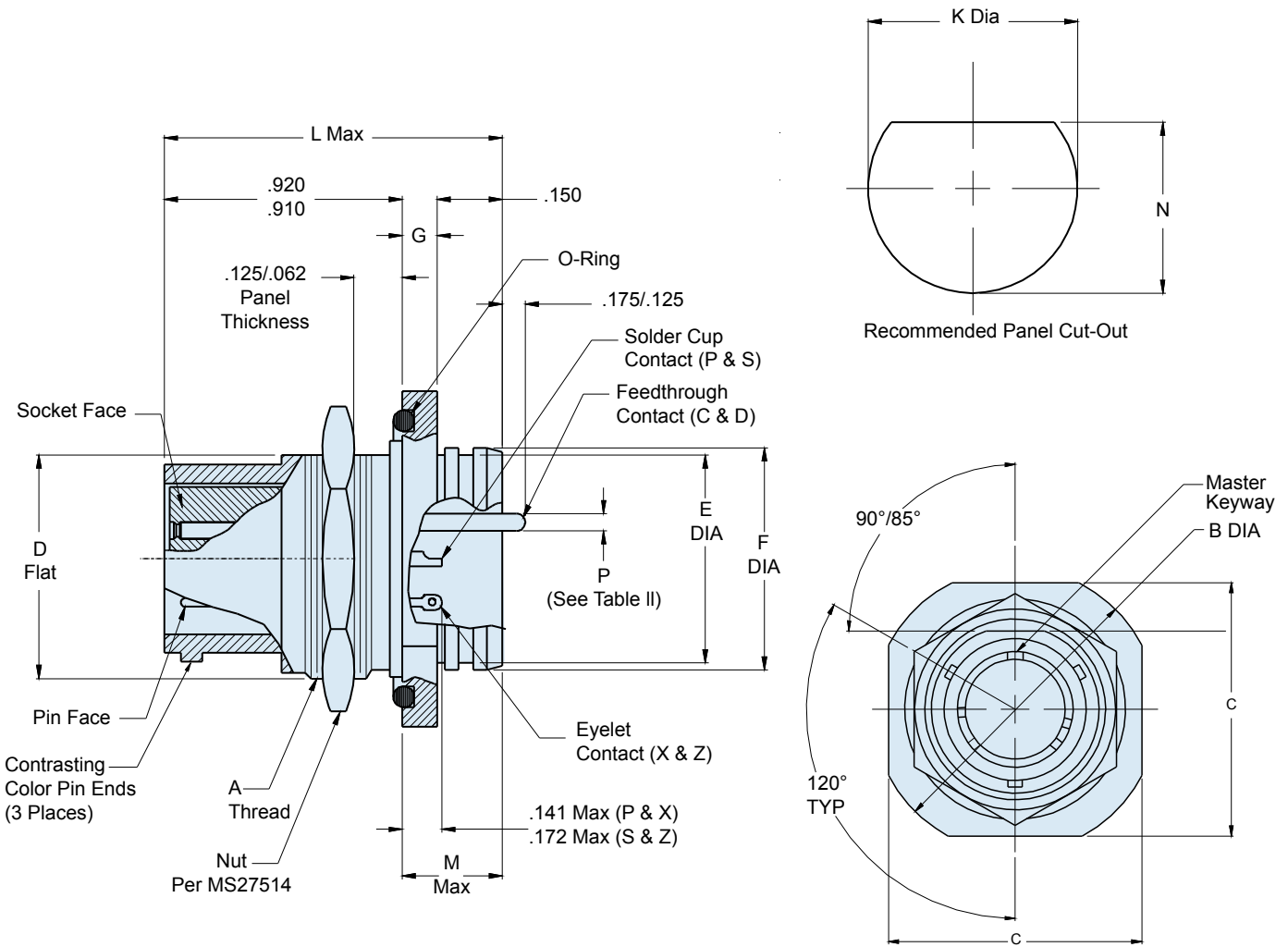

MS27470 Jam Nut Mount Hermetic Receptacle MIL-DTL-38999 Series I



D38999 QPL
Hermetics

How To Order: Commercial

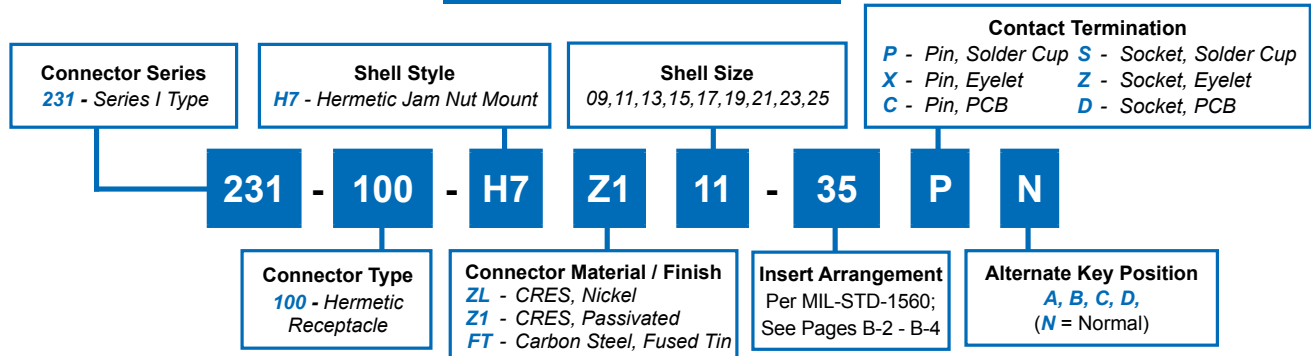

B

TABLE I: CONNECTOR DIMENSIONS

SHELL SIZE	A THREAD CLASS 2A	B DIA ±.016(0.4)	C ±.016(0.4)	D FLAT ±.005(0.1)	E DIA ±.011(0.3)	F DIA ±.005(0.1)
9/09	.6875-24 UNEF	1.188(30.2)	1.062(27.0)	.65(16.5)	.602(15.3)	.648(16.5)
11	.8125-20 UNEF	1.375(34.9)	1.25(31.8)	.75(19.1)	.726(18.4)	.772(19.6)
13	1.000-20 UNEF	1.5(38.1)	1.375(34.9)	.937(23.8)	.852(21.6)	.898(22.8)
15	1.125-18 UNEF	1.625(41.3)	1.5(38.1)	1.061(26.9)	.978(24.8)	1.024(26.0)
17	1.250-18 UNEF	1.75(44.5)	1.625(41.3)	1.186(30.1)	1.102(28.0)	1.148(29.2)
19	1.375-18 UNEF	1.938(49.2)	1.812(46.0)	1.311(33.3)	1.228(31.2)	1.274(32.4)
21	1.500-18 UNEF	2.062(52.4)	1.938(49.2)	1.436(36.5)	1.352(34.3)	1.398(35.5)
23	1.625-18 UNEF	2.188(55.6)	2.062(52.4)	1.561(39.6)	1.478(37.5)	1.524(38.7)
25	1.750-18 UNS	2.312(58.7)	2.188(55.6)	1.686(42.8)	1.602(40.7)	1.648(41.9)

TABLE I (CONTINUED): CONNECTOR DIMENSIONS

SHELL SIZE	G ±.016(0.4)	K DIA ±.005(0.1)	L MAX	M MAX	N ±.005(0.1)
9/09	.109(2.8)	.705(17.9)	1.200(30.5)	.280(7.1)	.665(16.9)
11	.109(2.8)	.827(21.0)	1.200(30.5)	.280(7.1)	.764(19.4)
13	.109(2.8)	1.012(25.7)	1.200(30.5)	.280(7.1)	.95(24.1)
15	.109(2.8)	1.139(28.9)	1.200(30.5)	.280(7.1)	1.079(27.4)
17	.109(2.8)	1.264(32.1)	1.200(30.5)	.280(7.1)	1.203(30.6)
19	.14(3.6)	1.389(35.3)	1.231(31.3)	.311(7.9)	1.328(33.7)
21	.14(3.6)	1.512(38.4)	1.231(31.3)	.311(7.9)	1.454(36.9)
23	.14(3.6)	1.639(41.6)	1.231(31.3)	.311(7.9)	1.579(40.1)
25	.14(3.6)	1.764(44.8)	1.231(31.3)	.311(7.9)	1.704(43.3)

TABLE II: CONTACT SIZE

PRINTED CIRCUIT TAIL CONFIGURATIONS
CONTACT STYLE C AND D



SIZE 12 AND SIZE 16

.050 ± .015
(1.27 ± 0.38)

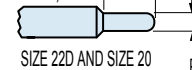

SIZE 22D AND SIZE 20

Contact Size	ø P
22D	.011 (0.28) .015 (0.38)
20	.024 (0.61) .028 (0.71)
16	.0635 (1.61) .0615 (1.56)
12	.095 (2.41) .093 (2.36)