

## Features

- Integrated PLL Loop Filter
- ESD Protection (4 kV HBM/200V MM; Except Pin 2: 4 kV HBM/100V MM) also at ANT1/ANT2
- High Output Power (8.0 dBm) with Low Supply Current (9.0 mA)
- Modulation Scheme ASK/FSK
  - FSK Modulation is Achieved by Connecting an Additional Capacitor Between the XTAL Load Capacitor and the Open Drain Output of the Modulating Microcontroller
- Easy to Design-in Due to Excellent Isolation of the PLL from the PA and Power Supply
- Single Li-cell for Power Supply
- Supply Voltage 2.0V to 4.0V in the Temperature Range of  $-40^{\circ}\text{C}$  to  $+85^{\circ}\text{C}$
- Package TSSOP8L
- Single-ended Antenna Output with High Efficient Power Amplifier
- CLK Output for Clocking the Microcontroller
- One-chip Solution with Minimum External Circuitry

## Applications

- Industrial/Aftermarket Remote Keyless Entry Systems
- Alarm, Telemetering, and Energy Metering Systems
- Remote Control Systems for Consumer and Industrial Markets
- Access Control Systems
- Home Automation
- Home Entertainment
- Toys

## 1. Description

The ATA8401 is a PLL transmitter IC, which has been developed for the demands of RF low-cost transmission systems for industrial applications at data rates up to 50 kBaud ASK and 32 kBaud FSK modulation scheme. The transmitting frequency range is 310 MHz to 350 MHz. It can be used in both FSK and ASK systems.

Figure 1-1. System Block Diagram

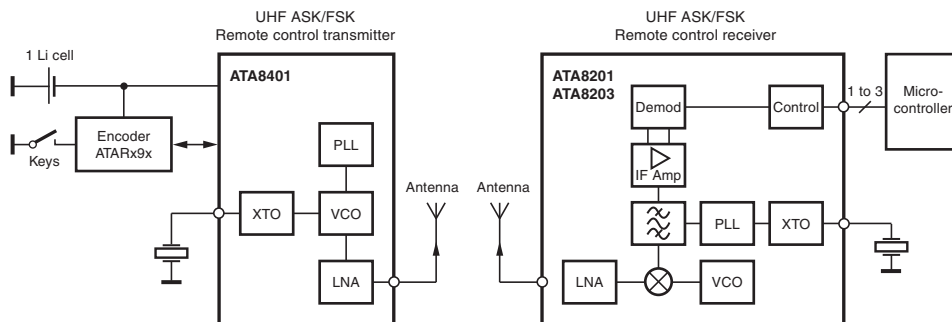

## UHF ASK/FSK Industrial Transmitter

## ATA8401

## 2. Pin Configuration

Figure 2-1. Pinning TSSOP8L

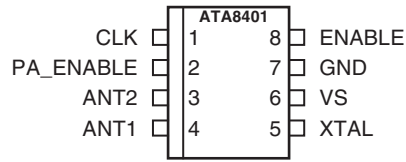

Table 2-1. Pin Description

Pin	Symbol	Function	Configuration
1	CLK	Clock output signal for microcontroller The clock output frequency is set by the crystal to $f_{XTAL}/4$	
2	PA_ENABLE	Switches on power amplifier used for ASK modulation	
3	ANT2	Emitter of antenna output stage	
4	ANT1	Open collector antenna output	

**Table 2-1.** Pin Description (Continued)

Pin	Symbol	Function	Configuration
5	XTAL	Connection for crystal	
6	VS	Supply voltage	See ESD protection circuitry (see <a href="#">Figure 4-5 on page 9</a> )
7	GND	Ground	See ESD protection circuitry (see <a href="#">Figure 4-5 on page 9</a> )
8	ENABLE	Enable input	

**Figure 2-2.** Block Diagram

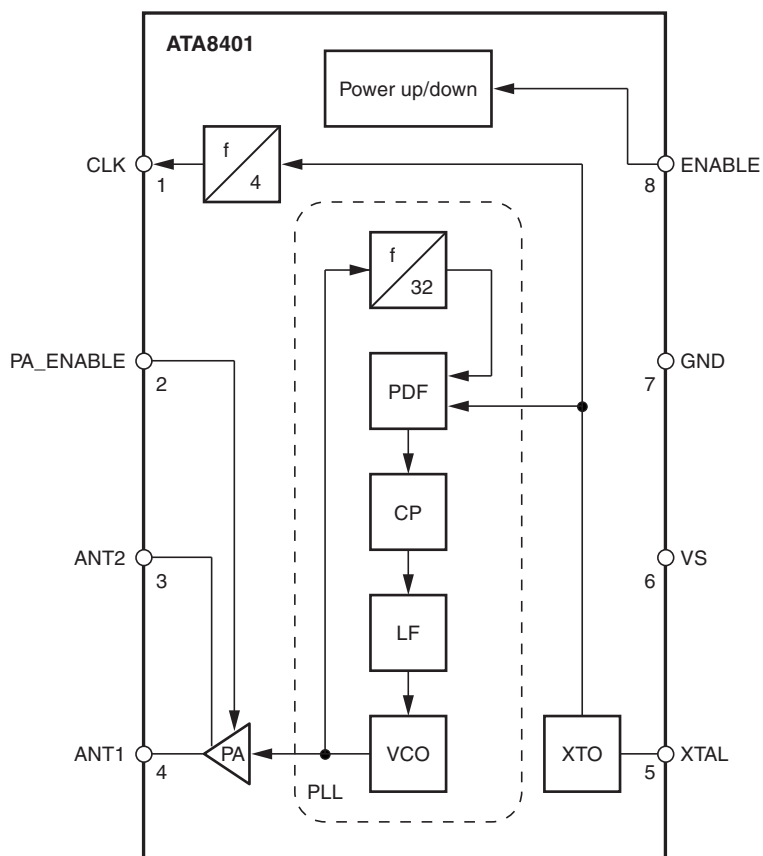

### 3. General Description

This fully integrated PLL transmitter allows particularly simple, low-cost RF miniature transmitters to be assembled. The VCO is locked to  $32 f_{XTAL}$ , and therefore a 9.8438 MHz crystal is needed for a 315 MHz transmitter. All other PLL and VCO peripheral elements are integrated.

The XTO is a series resonance oscillator so that only one capacitor together with a crystal connected in series to GND are needed as external elements.

The crystal oscillator together with the PLL typically needs  $< 3$  ms until the PLL is locked and the CLK output is stable. There is a wait time of  $\geq 3$  ms until the CLK is used for the microcontroller and the PA is switched on.

The power amplifier is an open-collector output delivering a current pulse, which is nearly independent from the load impedance. The delivered output power is therefore controllable via the connected load impedance.

This output configuration enables a simple matching to any kind of antenna or to  $50 \Omega$ . A high power efficiency of  $\eta = P_{out}/(I_{S,PA} V_S)$  of 40% for the power amplifier results when an optimized load impedance of  $Z_{Load} = (255 + j192) \Omega$  is used at 3V supply voltage.

### 4. Functional Description

If  $ENABLE = L$  and the  $PA\_ENABLE = L$ , the circuit is in standby mode, consuming only a very small amount of current, so that a lithium cell used as power supply can work for several years.

With  $ENABLE = H$  the XTO, PLL, and the CLK driver are switched on. If  $PA\_ENABLE$  remains L, only the PLL and the XTO are running, and the CLK signal is delivered to the microcontroller. The VCO locks to 32 times the XTO frequency.

With  $ENABLE = H$  and  $PA\_ENABLE = H$  the PLL, XTO, CLK driver, and the power amplifier are on. The power amplifier can be switched on and off with  $PA\_ENABLE$ . This is used to perform the ASK modulation.

#### 4.1 ASK Transmission

The ATA8401 is activated by  $ENABLE = H$ .  $PA\_ENABLE$  must remain L for typically  $\geq 3$  ms, then the CLK signal can be taken to clock the microcontroller and the output power can be modulated by means of the  $PA\_ENABLE$  pin. After transmission,  $PA\_ENABLE$  is switched to L and the microcontroller switches back to internal clocking. The ATA8401 is switched back to standby mode with  $ENABLE = L$ .

#### 4.2 FSK Transmission

The ATA8401 is activated by  $ENABLE = H$ .  $PA\_ENABLE$  must remain L for typically  $\geq 3$  ms, then the CLK signal can be taken to clock the microcontroller, and the power amplifier is switched on with  $PA\_ENABLE = H$ . The chip is then ready for FSK modulation. The microcontroller starts to switch on and off the capacitor between the XTAL load capacitor and GND with an open-drain output port, thus changing the reference frequency of the PLL. If the switch is closed, the output frequency is lower than if the switch is open. After transmission,  $PA\_ENABLE$  is switched to L, and the microcontroller switches back to internal clocking. The ATA8401 is switched back to standby mode with  $ENABLE = L$ .

The accuracy of the frequency deviation with XTAL pulling method is about  $\pm 25\%$  when the following tolerances are considered.

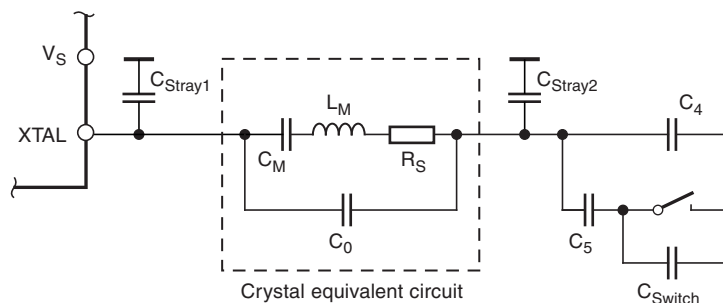
**Figure 4-1.** Tolerances of Frequency Modulation

Using  $C_4 = 8.2 \text{ pF} \pm 5\%$ ,  $C_5 = 10 \text{ pF} \pm 5\%$ , a switch port with  $C_{\text{Switch}} = 3 \text{ pF} \pm 10\%$ , stray capacitances on each side of the crystal of  $C_{\text{Stray1}} = C_{\text{Stray2}} = 1 \text{ pF} \pm 10\%$ , a parallel capacitance of the crystal of  $C_0 = 3.2 \text{ pF} \pm 10\%$ , and a crystal with  $C_M = 13 \text{ fF} \pm 10\%$ , typically results in an FSK deviation of  $\pm 21.5 \text{ kHz}$  with worst case tolerances of  $\pm 16.25 \text{ kHz}$  to  $\pm 28.01 \text{ kHz}$ .

### 4.3 CLK Output

An output CLK signal is provided for a connected microcontroller. The delivered signal is CMOS compatible if the load capacitance is lower than  $10 \text{ pF}$ .

#### 4.3.1 Clock Pulse Take-over

The clock of the crystal oscillator can be used for clocking the microcontroller. A special feature of Atmel®'s AVR® is that it starts with an integrated RC-oscillator to switch on the ATA8401 with  $\text{ENABLE} = \text{H}$ , and after  $3 \text{ ms}$  assumes the clock signal of the transmission IC, so that the message can be sent with crystal accuracy.

#### 4.3.2 Output Matching and Power Setting

The output power is set by the load impedance of the antenna. The maximum output power is achieved with a load impedance of  $Z_{\text{Load,opt}} = (255 + j192)\Omega$ . There must be a low resistive path to  $V_S$  to deliver the DC current.

The delivered current pulse of the power amplifier is  $9 \text{ mA}$ . The maximum output power is delivered to a resistive load of  $400\Omega$  if the  $1.0 \text{ pF}$  output capacitance of the power amplifier is compensated by the load impedance.

An optimum load impedance of:

$Z_{\text{Load}} = 400\Omega \parallel j/(2 \times \pi \times 1.0 \text{ pF}) = (255 + j192)\Omega$  thus results for the maximum output power of  $8 \text{ dBm}$ .

The load impedance is defined as the impedance seen from the ATA8401's ANT1, ANT2 into the matching network. Do not confuse this large signal load impedance with a small signal input impedance delivered as input characteristic of RF amplifiers and measured from the application into the IC instead of from the IC into the application for a power amplifier.

Less output power is achieved by lowering the real parallel part of  $400\Omega$  where the parallel imaginary part should be kept constant.

Output power measurement can be done with the circuit shown in [Figure 4-2](#). Note that the component values must be changed to compensate for the individual board parasitics until the ATA8401 has the right load impedance  $Z_{\text{Load,opt}} = (255 + j192)\Omega$ . Also the damping of the cable used to measure the output power must be calibrated out.

**Figure 4-2.** Output Power Measurement at  $f = 315$  MHz

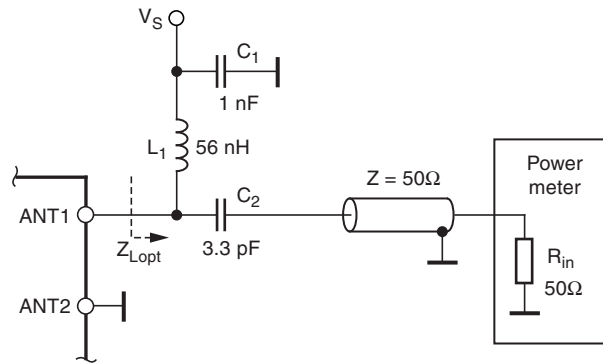

Note: For 345 MHz  $C_2$  has to be changed to 2.7 pF

## 4.4 Application Circuit

A value of  $C_3 = 68 \text{ nF}/X7R$  is recommended for the supply-voltage blocking capacitor  $C_3$  (see [Figure 4-3 on page 7](#) and [Figure 4-4 on page 8](#)).  $C_1$  and  $C_2$  are used to match the loop antenna to the power amplifier where  $C_1$  typically is 22 pF/NP0 and  $C_2$  is 10.8 pF/NP0 (18 pF + 27 pF in series). For  $C_2$ , two capacitors in series should be used to achieve a better tolerance value and to have the possibility of realizing the  $Z_{Load,opt}$  using standard valued capacitors.

$C_1$ , together with the pins of ATA8401 and the PCB board wires, forms a series resonance loop that suppresses the 1<sup>st</sup> harmonic. Therefore, the position of  $C_1$  on the PCB is important. Normally the best suppression is achieved when  $C_1$  is placed as close as possible to the pins ANT1 and ANT2.

The loop antenna should not exceed a width of 1.5 mm, otherwise the Q-factor of the loop antenna is too high.

$L_1$  ([50 nH to 100 nH) can be printed on PCB.  $C_4$  should be selected so that the XTO runs on the load resonance frequency of the crystal. Normally, a 15 pF load-capacitance crystal results in a value of 12 pF.

**Figure 4-3.** ASK Application Circuit

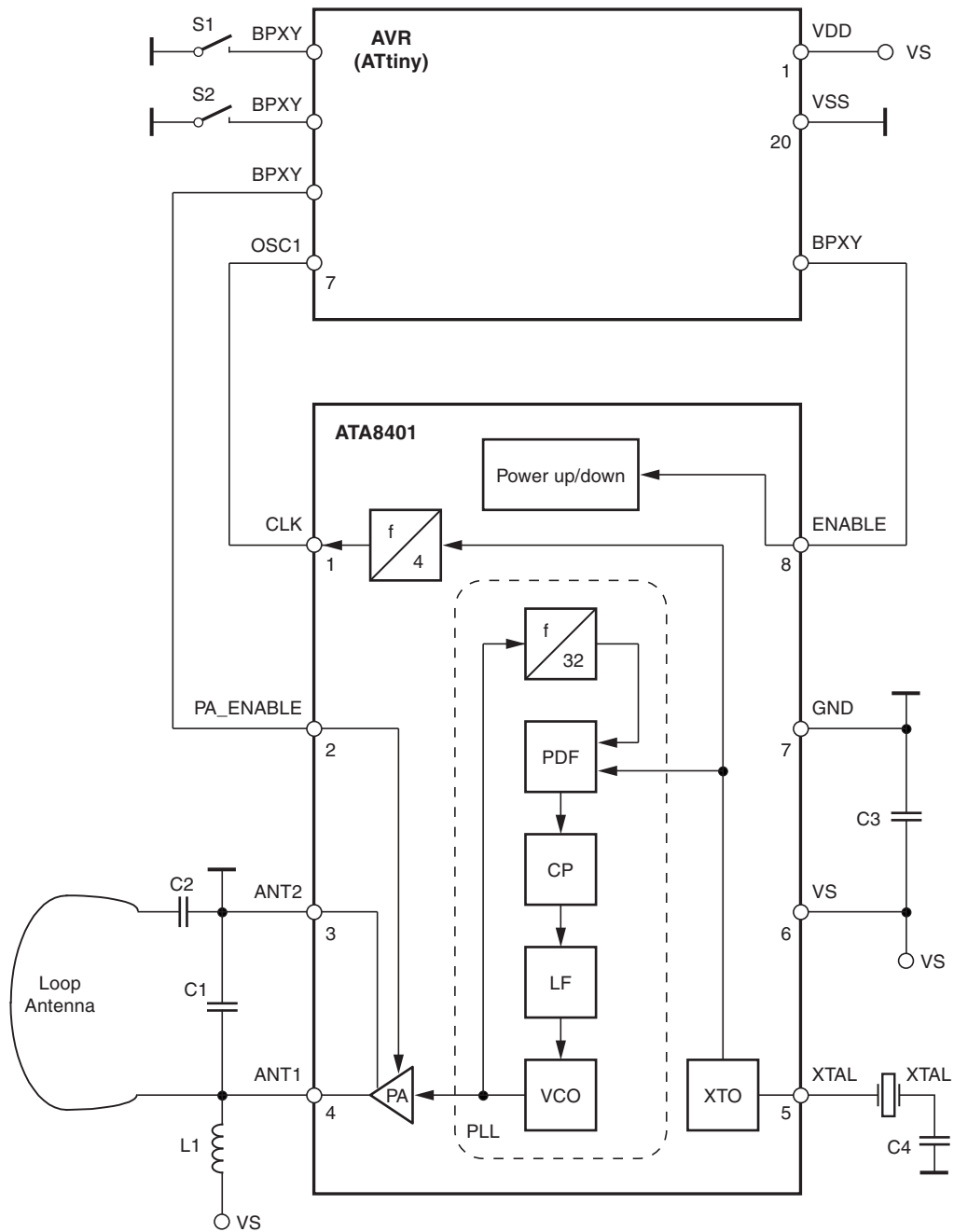

**Figure 4-4.** FSK Application Circuit

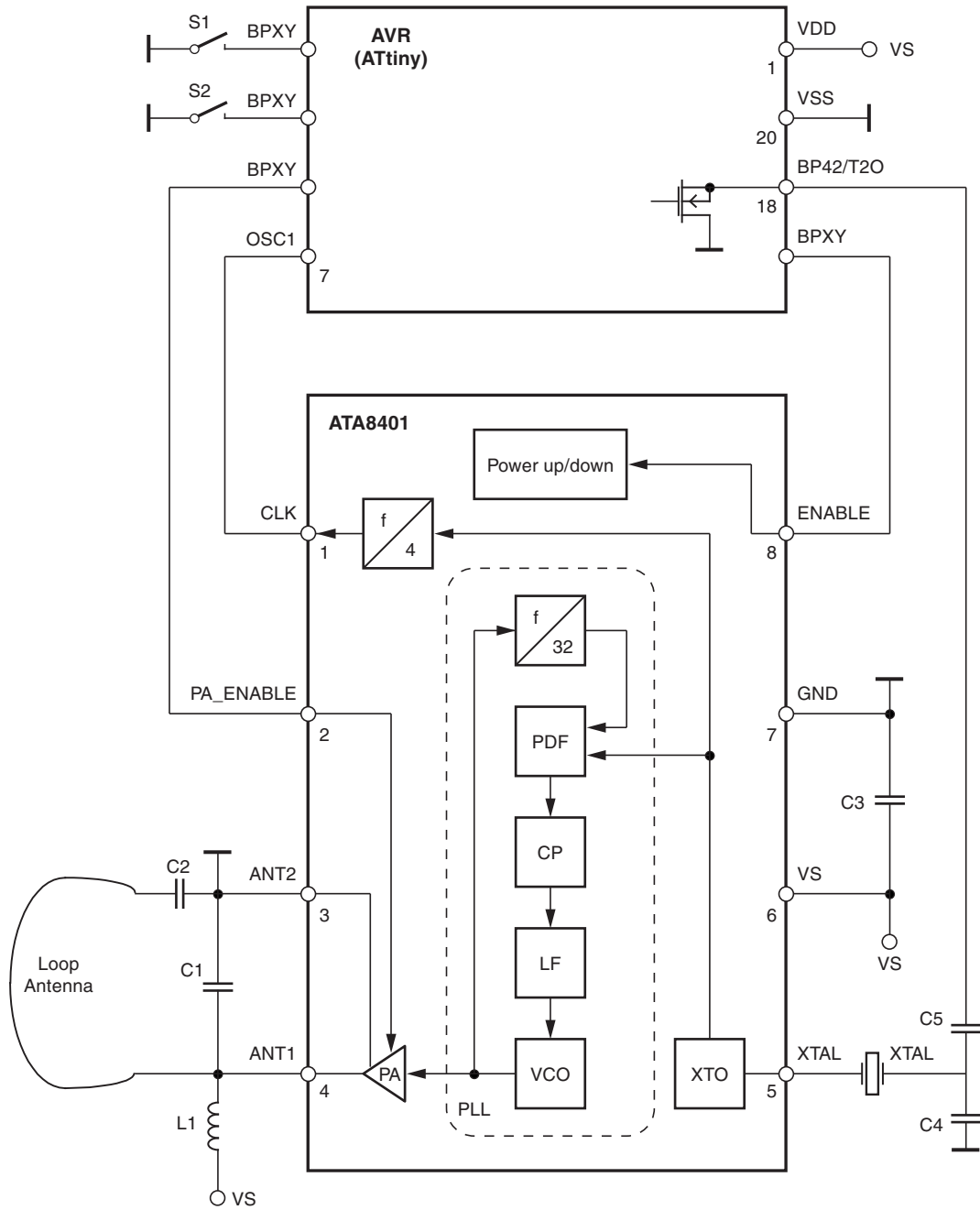
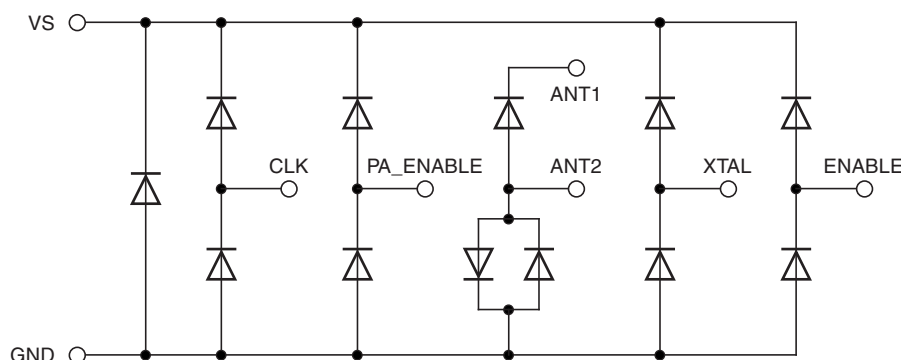



Figure 4-5. ESD Protection Circuit



## 5. Absolute Maximum Ratings

Stresses beyond those listed under “Absolute Maximum Ratings” may cause permanent damage to the device. This is a stress rating only and functional operation of the device at these or any other conditions beyond those indicated in the operational sections of this specification is not implied. Exposure to absolute maximum rating conditions for extended periods may affect device reliability.

Parameters	Symbol	Minimum	Maximum	Unit
Supply voltage	$V_S$		5	V
Power dissipation	$P_{tot}$		100	mW
Junction temperature	$T_j$		150	°C
Storage temperature	$T_{stg}$	-55	+85	°C
Ambient temperature	$T_{amb}$	-55	+85	°C
Input voltage	$V_{maxPA\_ENABLE}$	-0.3	$(V_S + 0.3)^{(1)}$	V

Note: 1. If  $V_S + 0.3$  is higher than 3.7V, the maximum voltage will be reduced to 3.7V.

## 6. Thermal Resistance

Parameters	Symbol	Value	Unit
Junction ambient	$R_{thJA}$	170	K/W

## 7. Electrical Characteristics

$V_S = 2.0V$  to  $4.0V$ ,  $T_{amb} = 25^\circ C$  unless otherwise specified.

Typical values are given at  $V_S = 3.0V$  and  $T_{amb} = 25^\circ C$ . All parameters are referred to GND (pin 7).

Parameters	Test Conditions	Symbol	Min.	Typ.	Max.	Unit
Supply current	Power down, $V_{ENABLE} < 0.25V$ , $-40^\circ C$ to $85^\circ C$ $V_{PA-ENABLE} < 0.25V$ , $25^\circ C$ (100% correlation tested)	$I_{S\_Off}$		< 10	350	nA nA
Supply current	Power up, PA off, $V_S = 3V$ , $V_{ENABLE} > 1.7V$ , $V_{PA-ENABLE} < 0.25V$	$I_S$		3.7	4.8	mA
Supply current	Power up, $V_S = 3.0V$ , $V_{ENABLE} > 1.7V$ , $V_{PA-ENABLE} > 1.7V$	$I_{S\_Transmit}$		9	11.6	mA

Note: 1. If  $V_S$  is higher than 3.6V, the maximum voltage will be reduced to 3.6V.

## 7. Electrical Characteristics (Continued)

$V_S = 2.0V$  to  $4.0V$ ,  $T_{amb} = 25^\circ C$  unless otherwise specified.

Typical values are given at  $V_S = 3.0V$  and  $T_{amb} = 25^\circ C$ . All parameters are referred to GND (pin 7).

Parameters	Test Conditions	Symbol	Min.	Typ.	Max.	Unit
Output power	$V_S = 3.0V$ , $T_{amb} = 25^\circ C$ , $f = 315 \text{ MHz}$ , $Z_{Load} = (255 + j192)\Omega$	$P_{Ref}$	6.0	8.0	10.5	dBm
Output power variation for the full temperature range	$T_{amb} = 25^\circ C$ , $V_S = 3.0V$ $V_S = 2.0V$	$\Delta P_{Ref}$ $\Delta P_{Ref}$			-1.5 -4.0	dB dB
Output power variation for the full temperature range	$T_{amb} = 25^\circ C$ , $V_S = 3.0V$ $V_S = 2.0V$ , $P_{Out} = P_{Ref} + \Delta P_{Ref}$	$\Delta P_{Ref}$ $\Delta P_{Ref}$			-2.0 -4.5	dB dB
Achievable output-power range	Selectable by load impedance	$P_{Out\_typ}$	0		8.0	dBm
Spurious emission	$f_{CLK} = f_0/128$ Load capacitance at pin CLK = 10 pF $f_O \pm 1 \times f_{CLK}$ $f_O \pm 4 \times f_{CLK}$ Other spurious are lower			-55 -52		dBc dBc
Oscillator frequency XTO (= phase comparator frequency)	$f_{XTO} = f_0/32$ $f_{XTAL}$ = resonant frequency of the XTAL, $C_M \leq 10 \text{ fF}$ , load capacitance selected accordingly $T_{amb} = 25^\circ C$	$f_{XTO}$		$f_{XTAL}$		ppm
PLL loop bandwidth				250		kHz
Phase noise of phase comparator	Referred to $f_{PC} = f_{XTO}$ , 25 kHz distance to carrier			-116	-110	dBc/Hz
In-loop phase noise PLL	25 kHz distance to carrier			-86	-80	dBc/Hz
Phase noise VCO	At 1 MHz At 36 MHz			-94 -125	-90 -121	dBc/Hz dBc/Hz
Frequency range of VCO		$f_{VCO}$	310		350	MHz
Clock output frequency (CMOS microcontroller compatible)				$f_0/128$		MHz
Voltage swing at pin CLK	$C_{Load} \leq 10 \text{ pF}$	$V_{Oh}$ $V_{Ol}$	$V_S \times 0.8$		$V_S \times 0.2$	V V
Series resonance R of the crystal		$R_s$			110	$\Omega$
Capacitive load at pin XTO					7	pF
FSK modulation frequency rate	Duty cycle of the modulation signal = 50%		0		32	kHz
ASK modulation frequency rate	Duty cycle of the modulation signal = 50%		0		50	kHz
ENABLE input	Low level input voltage High level input voltage Input current high	$V_{Il}$ $V_{Ih}$ $I_{In}$	1.7		0.25 20	V V $\mu A$
PA_ENABLE input	Low level input voltage High level input voltage Input current high	$V_{Il}$ $V_{Ih}$ $I_{In}$	1.7		0.25 $V_S^{(1)}$ 5	V V $\mu A$

Note: 1. If  $V_S$  is higher than 3.6V, the maximum voltage will be reduced to 3.6V.

## 8. Ordering Information

Extended Type Number	Package	MOQ	Remarks
ATA8401-6AQY	TSSOP8L	5000 pcs	Taped and reeled, Pb-free

## 9. Package Information

Package: TSSOP 8L

Dimensions in mm

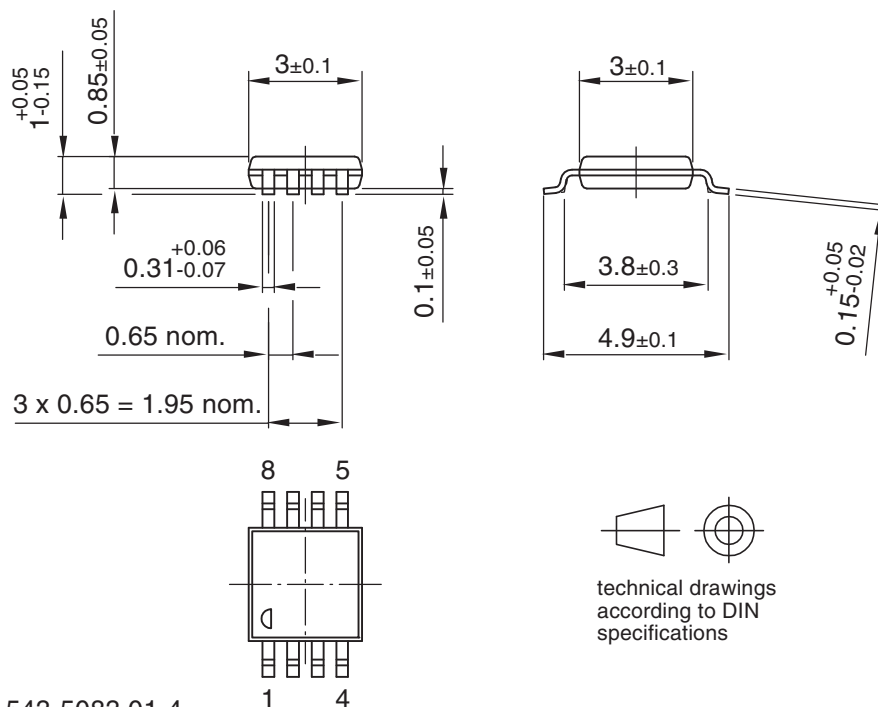

Drawing-No.: 6.543-5083.01-4

Issue: 2; 15.03.04

## 10. Revision History

Please note that the following page numbers referred to in this section refer to the specific revision mentioned, not to this document.

Revision No.	History
4984C-INDCO-04/09	<ul style="list-style-type: none"> <li>Section 4.3.1 "Clock Pulse Take-over" on page 5 changed</li> <li>Figure 4-3 "ASK Application Circuit" on page 7 changed</li> <li>Figure 4-4 "FSK Application Circuit" on page 8 changed</li> </ul>
4984B-INDCO-11/08	<ul style="list-style-type: none"> <li>Put datasheet in the newest template</li> <li>Section 4.3.1 "Clock Pulse Take-over" on page 5 changed</li> </ul>



## Headquarters

---

**Atmel Corporation**  
2325 Orchard Parkway  
San Jose, CA 95131  
USA  
Tel: 1(408) 441-0311  
Fax: 1(408) 487-2600

## International

---

**Atmel Asia**  
Unit 1-5 & 16, 19/F  
BEA Tower, Millennium City 5  
418 Kwun Tong Road  
Kwun Tong, Kowloon  
Hong Kong  
Tel: (852) 2245-6100  
Fax: (852) 2722-1369

**Atmel Europe**  
Le Krebs  
8, Rue Jean-Pierre Timbaud  
BP 309  
78054  
Saint-Quentin-en-Yvelines Cedex  
France  
Tel: (33) 1-30-60-70-00  
Fax: (33) 1-30-60-71-11

**Atmel Japan**  
9F, Tonetsu Shinkawa Bldg.  
1-24-8 Shinkawa  
Chuo-ku, Tokyo 104-0033  
Japan  
Tel: (81) 3-3523-3551  
Fax: (81) 3-3523-7581

## Product Contact

---

**Web Site**  
[www.atmel.com](http://www.atmel.com)

**Technical Support**  
[industrial@atmel.com](mailto:industrial@atmel.com)

**Sales Contact**  
[www.atmel.com/contacts](http://www.atmel.com/contacts)

**Literature Requests**  
[www.atmel.com/literature](http://www.atmel.com/literature)

---

**Disclaimer:** The information in this document is provided in connection with Atmel products. No license, express or implied, by estoppel or otherwise, to any intellectual property right is granted by this document or in connection with the sale of Atmel products. **EXCEPT AS SET FORTH IN ATMEL'S TERMS AND CONDITIONS OF SALE LOCATED ON ATMEL'S WEB SITE, ATMEL ASSUMES NO LIABILITY WHATSOEVER AND DISCLAIMS ANY EXPRESS, IMPLIED OR STATUTORY WARRANTY RELATING TO ITS PRODUCTS INCLUDING, BUT NOT LIMITED TO, THE IMPLIED WARRANTY OF MERCHANTABILITY, FITNESS FOR A PARTICULAR PURPOSE, OR NON-INFRINGEMENT. IN NO EVENT SHALL ATMEL BE LIABLE FOR ANY DIRECT, INDIRECT, CONSEQUENTIAL, PUNITIVE, SPECIAL OR INCIDENTAL DAMAGES (INCLUDING, WITHOUT LIMITATION, DAMAGES FOR LOSS OF PROFITS, BUSINESS INTERRUPTION, OR LOSS OF INFORMATION) ARISING OUT OF THE USE OR INABILITY TO USE THIS DOCUMENT, EVEN IF ATMEL HAS BEEN ADVISED OF THE POSSIBILITY OF SUCH DAMAGES.** Atmel makes no representations or warranties with respect to the accuracy or completeness of the contents of this document and reserves the right to make changes to specifications and product descriptions at any time without notice. Atmel does not make any commitment to update the information contained herein. Unless specifically provided otherwise, Atmel products are not suitable for, and shall not be used in, automotive applications. Atmel's products are not intended, authorized, or warranted for use as components in applications intended to support or sustain life.

© 2008 Atmel Corporation. All rights reserved. Atmel®, Atmel logo and combinations thereof, AVR® and others are registered trademarks or trademarks of Atmel Corporation or its subsidiaries. Other terms and product names may be trademarks of others.