

UNCONTROLLED DOCUMENT

PART NUMBER		REV.
GT-CM600L		A
REV.	E.C.N. NUMBER AND REVISION COMMENTS	DATE
A	E.C.N. #11148.	12.12.06

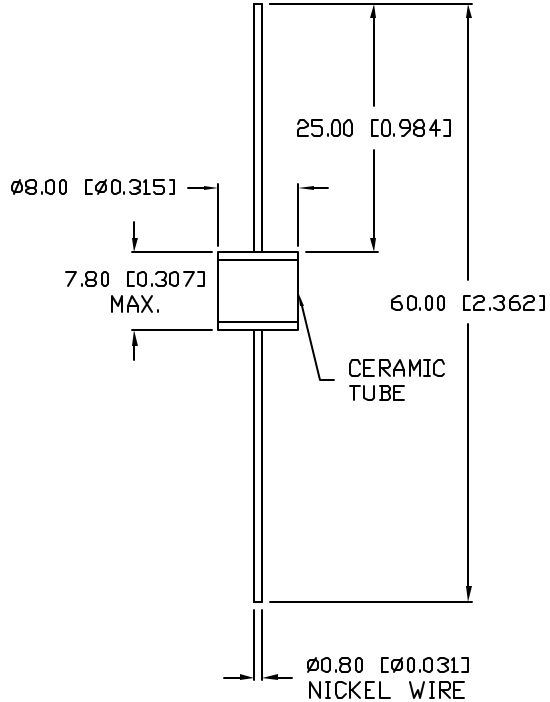

ELECTRICAL SPECIFICATIONS

PARAMETER	VALUE	TEST CONDITION
D.C. FIRING VOLTAGE:	60DV±15% D.C.	(dv/dt 10DV/S)
IMPULSE FIRING VOLTAGE:	90DV D.C. MAX.	(dv/dt 10DV/μS)
IMPULSE CURRENT:	10KA MAX.	(B/20μS)
D.C. HOLDOVER VOLTAGE:	20DV D.C. MAX.	(150mS MAX.)
A.C. DISCHARGE CURRENT:	10A	(1S X 10 TIMES)
INSULATION RESISTANCE:	10 <sup>3</sup> MΩ MIN.	(50 OR 100VDC)
INTER-ELECTRODE CAPACITANCE:	0.5 PF MAX.	1.0kHz

ENVIRONMENTAL SPECIFICATIONS PER MIL-STD 202

TEST	METHODE	CONDITON	RATING
VIBRATION TESTING:	204B	C	10-55Hz, .06DA
SHOCK	213A	C	100 g
HUMIDITY:	103B	B	95% Re. HUMIDITY
TEMPERATURE CYCLING:	102A	C	- 65 TO + 125 °C
BAROMETRIC PRESSURE:	105C	B	50,000 ft.
THERMAL SHOCK:	107	B	- 65 TO + 125 °C
SOLDERABILITY:	208	B	

RESPONSE TIME

SURGE TYPE	(Rt MAX.)
1Kv/mS	1 x 10 <sup>-5</sup> sec.
1Kv/μS	1 x 10 <sup>-6</sup> sec.
5Kv/μS	1 x 10 <sup>-9</sup> sec.



UNCONTROLLED DOCUMENT

\*UNLESS OTHERWISE SPECIFIED TOLERANCES PER DECIMAL PRECISION ARE: X=±1 (±0.039), X.X=±0.5 (±0.020), X.XX=±0.25 (±0.010), X.XXX=±0.127 (±0.005). LEAD SIZE=±0.05 (±0.002), LEAD LENGTH=±0.75 (±0.030). MIN= -0.00, MAX.= +0.00

REV.	PART NUMBER
A	GT-CM600L

**CONFIDENTIAL INFORMATION**  
 THE INFORMATION CONTAINED IN THIS DOCUMENT IS THE PROPERTY OF LUMEX INC. EXCEPT AS SPECIFICALLY AUTHORIZED IN WRITING BY LUMEX INC, THE HOLDER OF THIS DOCUMENT SHALL KEEP ALL INFORMATION CONTAINED HEREIN CONFIDENTIAL AND SHALL PROTECT SAME IN WHOLE OR IN PART FROM DISCLOSURE AND DISSEMINATION TO ALL THIRD PARTIES.



290 E. HELEN ROAD  
 PALATINE, IL 60067-6976  
 PHONE: +1.847.359.2790  
 US WEB: www.lumex.com  
 TW WEB: www.lumex.com.tw

HEAVY DUTY CERAMIC SURGE PROTECTOR, 2 LEADED.

**RELIABILITY NOTE**  
 OUR MANY YEARS OF EXPERIENCE DATA ACCUMULATION INDICATE THAT SOLDER HEAT IS A MAJOR CAUSE OF EARLY AND FUTURE FAILURE. PLEASE PAY ATTENTION TO YOUR SOLDERING PROCESS.

DRAWN BY:	CHECKED BY:	APPROVED BY:	DATE: 12.12.06
JC			PAGE: 1 OF 1
			SCALE: N/A