

GENERAL INFORMATION **1**

ULTRA-BUSY INTERFACE DRIVERS **2**

MEDIUM-CURRENT INTERFACE DRIVERS **3**



HIGH-CURRENT INTERFACE DRIVERS **4**

BIG-POWER SMART POWER INTERFACE DRIVERS **5**

MILITARY DEVICES **6**

INDUSTRIAL AND SPECIAL APPLICATIONS **7**

PACKAGE INFORMATION **8**

SECTION 4—HIGH-CURRENT (≥ 1 A) INTERFACE DRIVERS

Selection Guide	4-2
ULN-2061M through 2075B 1.5 A Darlington Switches	4-3
UDN-2540B Quad 1.25 A Power Driver	4-14
UDN-2545B Universal Quad 2.5 A Driver	4-17
UDN-2841B and 2845B Quad 1.5 A Darlington Drivers	4-19
UDN-2878W and 2879W Quad 4 A Darlington Switches	4-25
UDN-2906W 3-Phase 2 A Brushless DC Motor Driver	4-2
UDN-2931B/W 3-Channel 2 A Half-Bridge Drivers	4-31
UDN-2935Z 2 A Half-Bridge Motor Driver	4-34
UDN-2936W and 2937W 3-Phase 3 A Brushless DC Motor Drivers	4-40
UDN-2938W and 2939B 3-Phase 4 A Brushless DC Motor Drivers	4-46
UDN-2941B Quad 2 A Source Driver	4-48
UDN-2943Z 1 A Half-Bridge Motor Driver	4-51
UDN-2944W Quad 4 A High-Voltage Source Driver	4-55
UDN-2948W Quad 6 A High-Voltage Source Driver	4-58
UDN-2949Z 2 A Half-Bridge Motor Driver	See UDN-2950Z
UDN-2950Z 2 A Half-Bridge Motor Driver	4-34
UDN-2951Z 8 A Half-Bridge Driver	4-61
UDN-2952B/W 2 A Full-Bridge Motor Drivers	4-64
UDN-2953B and 2954W 2 A Full-Bridge Motor Drivers	4-70
UDN-2955W 8 A Half-Bridge Motor Driver	4-61
UDN-2962B/W Dual 3 A PWM Solenoid/Motor Drivers	4-75
UDN-2965W-2 Dual 4 A Solenoid/Motor Driver	4-81
UDN-2975W and 2976W Dual 4 A Solenoid Drivers	4-86
UDN-2998W Dual 2 A Full-Bridge Motor Driver	4-89
ULN-3751Z Power Operational Amplifier	4-93
ULN-3753B/W Dual Power Operational Amplifiers	4-98
ULN-3755B/W Dual Power Operational Amplifiers	4-107
UDN-5725M Dual Peripheral/Power Driver	4-117
UDN-7078 Quad High-Current Darlington Switches	4-121
 Application Notes:	
Power Interface ICs for Motor Drive Applications	4-124
Switching Inductive Loads with Power Interface ICs	4-139
An Integrated 3-Phase Brushless DC Motor Driver	4-143
Power Op Amp Applications	4-147
 See Also:	
UCN-5813 and 5814B 4-Bit Latched 1.5 A Drivers	5- 41
UCN-5825 and 5826B 4-Bit Serial-Input, Latched 2 A Drivers	5- 59
ULN-7064B through 7074B Quad High-Voltage, 1 A Darlington Arrays	2-15



HIGH-CURRENT INTERFACE DRIVERS

SELECTION GUIDE (in order of tested output current rating)

I_{OUT}	V_{OUT}	Outputs	Device Type	Page
± 1.0 A	26 V	Half-Bridge	UDN-2943Z	4-51
± 1.0 A Linear	28 V	Power Op Amp	ULN-3751Z	4-93
± 1.0 A Linear	40 V	Dual Power Op Amp	ULN-3753B/W	4-98
± 1.0 A Linear	40 V	Dual Power Op Amp	ULN-3755B/W	4-107
1.0 A	50 V	Sink 4†	UCN-5813/14B	5-41
1.0 A	70 V	Sink 2	UDN-5725M	4-117
1.0 A	80 V	Sink 4†	UCN-5813/14B-1	5-41
1.0 A	150 V	Sink 4	ULN-7064/68/74B	2-15
1.25 A	50 V	Source/Sink 2	ULN-2061M	4-3
1.25 A	50 V	Sink 4	ULN-2064/66/68/70B	4-3
1.25 A	50 V	Source/Sink 4	ULN-2074B	4-3
1.25 A	60 V	Sink 4	UDN-2540B	4-14
- 1.5 A	35 V	Source 4	UDN-2941B	4-48
1.5 A	- 50 V	Sink 4	UDN-2841/45B	4-19
- 1.5 A	- 50 V	Source 4	UDN-2845B	4-19
1.5 A	80 V	Source/Sink 2	ULN-2062M	4-3
1.5 A	80 V	Sink 4	ULN-2065/67/69/71B	4-3
1.5 A	80 V	Source/Sink 4	ULN-2075B	4-3
1.75 A	60 V	Sink 4†	UCN-5825B	5-59
1.75 A	80 V	Sink 4†	UCN-5826B	5-59
± 2.0 A	15 V	3 × Half-Bridge	UDN-2906W	*
± 2.0 A	15 V	3 × Half-Bridge	UDN-2931B/W	4-31
± 2.0 A	35 V	Half-Bridge	UDN-2935/50Z	4-34
± 2.0 A	40 V	Full-Bridge	UDN-2952B/W	4-64
± 2.0 A	50 V	Full-Bridge	UDN-2953B/54W	4-70
± 2.0 A	50 V	2 × Full-Bridge	UDN-2998W	4-89
2.0 A	80 V	Sink 4	UDN-2545B	4-17
± 3.0 A	45 V	3 × Half-Bridge	UDN-2936/37W	4-40
3.0 A PWM	45 V	Source/Sink 2	UDN-2962W	4-75
3.0 A	90 V	Sink 4	UDN-7078W	4-121
4.0 A	50 V	Sink 4	UDN-2878W	4-25
4.0 A	50 V	Sink 3	UDN-2938W/39B	4-46
4.0 A	50 V	Source/Sink 2	UDN-2975W	4-86
4.0 A PWM	50 V	Source/Sink 2	UDN-2965W-2	4-81
4.0 A	60 V	Source/Sink 2	UDN-2976W	4-86
- 4.0 A	60 V	Source 4	UDN-2944W	4-55
4.0 A	80 V	Sink 4	UDN-2879W	4-25
- 6.0 A	60 V	Source 4	UDN-2948W	4-58
± 8.0 A	50 V	Half-Bridge	UDN-2951Z/55W	4-61

Current ratings shown are maximum tested condition; allowable peak, or start-up currents are generally higher; voltage ratings shown are maximum allowable. Devices with ratings of less than 1 A are listed in Section 3.

†Latched Smart Power drivers.

*New product. Contact factory for information.

ULN-2061M THROUGH ULN-2075B 1.5 A DARLINGTON SWITCHES

FEATURES

- TTL, DTL, CMOS Compatible inputs
- Transient-Protected Outputs
- Loads to 480 Watts
- Plastic Dual In-Line Packages
- Heat-Sink Contact Tabs on Quad Arrays

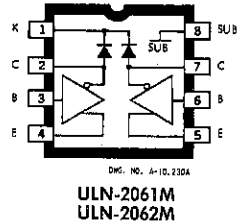

HIGH-VOLTAGE, HIGH-CURRENT Darlington arrays ULN-2061M through ULN-2075B are designed as interface between low-level logic and a variety of peripheral loads such as relays, solenoids, dc and stepper motors, multiplexed LED and incandescent displays, heaters, and similar loads to 480 watts (1.5 A per output, 80 V, 26% duty cycle).

The devices have a minimum output breakdown of 50 V and a minimum $V_{CE(SUS)}$ of 35 V measured at 100 mA, or a minimum output breakdown of 80 V and a minimum $V_{CE(SUS)}$ of 50 V.

Dual-driver arrays ULN-2061M and ULN-2062M

are used for common-emitter (externally connected), or emitter-follower applications. Both devices are supplied in miniature 8-pin dual in-line plastic packages.

Quad drivers ULN-2064B, ULN-2065B, ULN-2068B and ULN-2069B are intended for use with TTL, low-speed TTL, and 5 V MOS logic. Types ULN-2065B and ULN-2069B are selected for the 80 V minimum output breakdown specification. Types ULN-2068B and ULN-2069B have pre-driver stages and are most suitable for applications requiring high gain (low input-current loading).

4

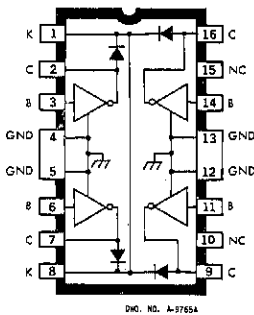

ULN-2064B
ULN-2065B

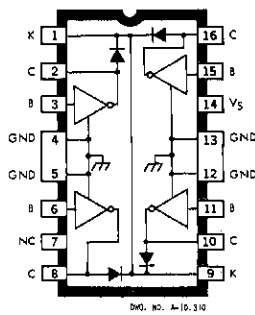

ULN-2068B
ULN-2069B

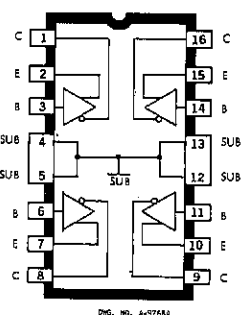

ULN-2074B
ULN-2075B

ULN-2061M THROUGH ULN-2075B
1.5 A DARLINGTON SWITCHES

Isolated Darlington arrays ULN-2074B and ULN-2075B are identical to Types ULN-2064B and ULN-2065B except for the isolated Darlington pinout and the deletion of suppression diodes. These switches are for emitter-follower or similar isolated-Darlington applications.

All quad Darlington arrays (suffix "B" devices) are supplied in a 16-pin plastic dual in-line package with heat-sink contact tabs. A copper-alloy lead frame provides maximum power dissipation using standard cooling methods. This lead configuration facilitates attachment of external heat sinks for increased power dissipation with standard IC sockets and printed wiring boards.

ABSOLUTE MAXIMUM RATINGS
at +25°C Free-Air Temperature
for Any One Driver
(unless otherwise noted)

Output Voltage, V_{CEX}	See Guide
Output Sustaining Voltage, $V_{CE(SUS)}$	See Guide
Output Current, I_{OUT} (Note 1)	1.75 A
Input Voltage, V_{IN} (Note 2)	See Guide
Input Current, I_B (Note 3)	25 mA
Supply Voltage, V_S (ULN-2068/69B)	10 V
Total Package Power Dissipation	See Graph
Operating Temperature Range, T_A	-20°C to +85°C
Storage Temperature Range, T_S	-55°C to +150°C

NOTES:

1. Allowable combinations of output current, number of outputs conducting, and duty cycle are shown on following pages.
2. Input voltage is referenced to the substrate (no connection to other pins) for Type ULN-2061/62M and ULN-2074/75B; reference is ground for all other types.
3. Input current may be limited by maximum allowable input voltage.

SELECTION GUIDE

Part Number	MAX. V_{CEX}	Min. $V_{CE(SUS)}$	Max. V_{IN}	Application
ULN-2061M	50 V	35 V	30 V	TTL, DTL, Schottky TTL,
ULN-2062M	80 V	50 V	60 V	and 5 V CMOS
ULN-2064B	50 V	35 V	15 V	TTL, DTL, Schottky TTL
ULN-2065B	80 V	50 V	15 V	and 5 V CMOS
ULN-2068B	50 V	35 V	15 V	TTL, DTL, Schottky TTL,
ULN-2069B	80 V	50 V	15 V	and 5 V CMOS
ULN-2074B	50 V	35 V	30 V	General Purpose
ULN-2075B	80 V	50 V	60 V	

ALLOWABLE POWER DISSIPATION
AS A FUNCTION OF TEMPERATURE

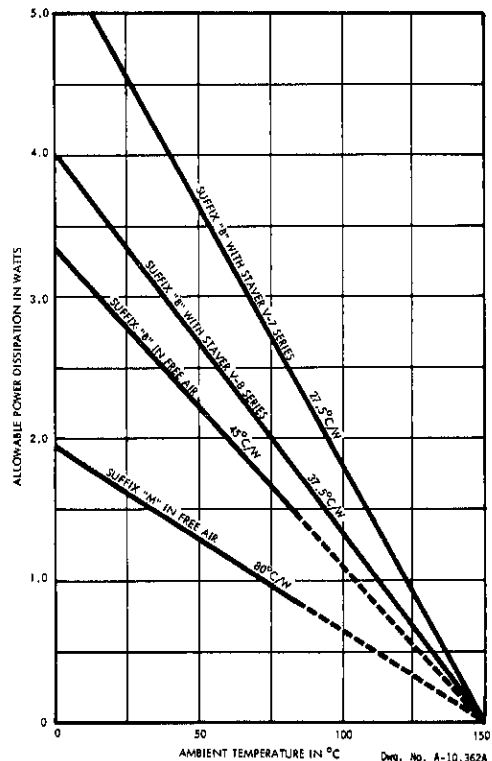

ULN-2061M AND ULN-2062M

PARTIAL SCHEMATIC

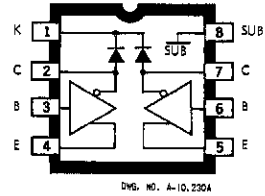
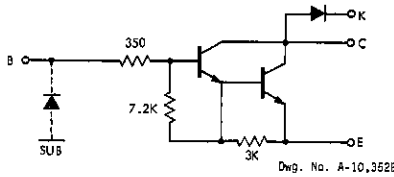

ELECTRICAL CHARACTERISTICS at +25°C (unless otherwise noted)

Characteristic	Symbol	Test Fig.	Applicable Devices	Test Conditions	Limits		
					Min.	Max.	Units
Output Leakage Current	I_{CEX}	1	ULN-2061M	$V_{CE} = 50\text{ V}$	—	100	μA
				$V_{CE} = 50\text{ V}, T_A = 70^\circ\text{C}$	—	500	μA
			ULN-2062M	$V_{CE} = 80\text{ V}$	—	100	μA
				$V_{CE} = 80\text{ V}, T_A = 70^\circ\text{C}$	—	500	μA
Output Sustaining Voltage	$V_{CE(SUB)}$	2	ULN-2061M	$I_C = 100\text{ mA}, V_{IN} = 0.4\text{ V}$	35	—	V
			ULN-2062M	$I_C = 100\text{ mA}, V_{IN} = 0.4\text{ V}$	50	—	V
Collector-Emitter Saturation Voltage	$V_{CE(SAT)}$	3	Both	$I_C = 500\text{ mA}, I_B = 625\text{ }\mu\text{A}$	—	1.1	V
				$I_C = 750\text{ mA}, I_B = 935\text{ }\mu\text{A}$	—	1.2	V
				$I_C = 1.0\text{ A}, I_B = 1.25\text{ mA}$	—	1.3	V
				$I_C = 1.25\text{ A}^*, I_B = 2.0\text{ mA}$	—	1.4	V
			ULN-2062M	$I_C = 1.5\text{ A}^*, I_B = 2.25\text{ mA}$	—	1.5	V
Input Current	$I_{IN(OH)}$	4	Both	$V_{IN} = 2.4\text{ V}$	1.4	4.3	mA
				$V_{IN} = 3.75\text{ V}$	3.3	9.6	mA
Input Voltage	$V_{IN(OH)}$	5	Both	$V_{CE} = 2.0\text{ V}, I_C = 1.0\text{ A}$	—	2.0	V
			ULN-2061M	$V_{CE} = 2.0\text{ V}, I_C = 1.25\text{ A}^*$	—	2.5	V
			ULN-2062M	$V_{CE} = 2.0\text{ V}, I_C = 1.5\text{ A}^*$	—	2.5	V
Turn-On Delay	t_{PLH}	—	Both	$0.5 E_{in}$ to $0.5 E_{out}$	—	1.0	μs
Turn-Off Delay	t_{PHL}	—	Both	$0.5 E_{in}$ to $0.5 E_{out}$	—	1.5	μs
Clamp Diode Leakage Current	I_R	6	ULN-2061M	$V_R = 50\text{ V}$	—	50	μA
				$V_R = 50\text{ V}, T_A = 70^\circ\text{C}$	—	100	μA
			ULN-2062M	$V_R = 80\text{ V}$	—	50	μA
				$V_R = 80\text{ V}, T_A = 70^\circ\text{C}$	—	100	μA
Clamp Diode Forward Voltage	V_F	7	Both	$I_F = 1.0\text{ A}$	—	1.75	V
				$I_F = 1.5\text{ A}$	—	2.0	V

*Pulse-Test

**ULN-2061M THROUGH ULN-2075B
1.5 A DARLINGTON SWITCHES**

ULN-2064B AND ULN-2065B

PARTIAL SCHEMATIC

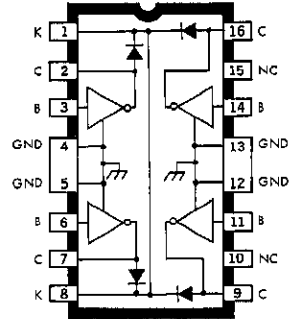
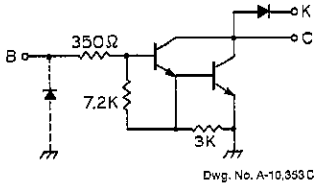

(SIMILAR TO ULN-2074B AND ULN-2075B)

ELECTRICAL CHARACTERISTICS at ± 25°C (unless otherwise noted)

Characteristic	Symbol	Test Fig.	Applicable Devices	Test Conditions	Limits		
					Min.	Max.	Units
Output Leakage Current	I_{CEX}	1	ULN-2064B	$V_{CE} = 50 \text{ V}$	—	100	μA
				$V_{CE} = 50 \text{ V}, T_A = 70^\circ\text{C}$	—	500	μA
			ULN-2065B	$V_{CE} = 80 \text{ V}$	—	100	μA
				$V_{CE} = 80 \text{ V}, T_A = 70^\circ\text{C}$	—	500	μA
Output Sustaining Voltage	$V_{CE(SUS)}$	2	ULN-2064B	$I_C = 100 \text{ mA}, V_{IN} = 0.4 \text{ V}$	35	—	V
			ULN-2065B	$I_C = 100 \text{ mA}, V_{IN} = 0.4 \text{ V}$	50	—	V
Collector-Emitter Saturation Voltage	$V_{CE(SAT)}$	3	Both	$I_C = 500 \text{ mA}, I_B = 625 \mu\text{A}$	—	1.1	V
				$I_C = 750 \text{ mA}, I_B = 935 \mu\text{A}$	—	1.2	V
				$I_C = 1.0 \text{ A}, I_B = 1.25 \text{ mA}$	—	1.3	V
				$I_C = 1.25 \text{ A}, I_B = 2.0 \text{ mA}$	—	1.4	V
			ULN-2065B	$I_C = 1.5 \text{ A}, I_B = 2.25 \text{ mA}$	—	1.5	V
Input Current	$I_{IN(ON)}$	4	Both	$V_{IN} = 2.4 \text{ V}$	1.4	4.3	mA
				$V_{IN} = 3.75 \text{ V}$	3.3	9.6	mA
Input Voltage	$V_{IN(ON)}$	5	Both	$V_{CE} = 2.0 \text{ V}, I_C = 1.0 \text{ A}$	—	2.0	V
			ULN-2064B	$V_{CE} = 2.0 \text{ V}, I_C = 1.25 \text{ A}$	—	2.5	V
			ULN-2065B	$V_{CE} = 2.0 \text{ V}, I_C = 1.5 \text{ A}$	—	2.5	V
Turn-On Delay	t_{PLH}	—	Both	$0.5 E_{in}$ to $0.5 E_{out}$	—	1.0	μs
Turn-Off Delay	t_{FHL}	—	Both	$0.5 E_{in}$ to $0.5 E_{out}$	—	1.5	μs
Clamp Diode Leakage Current	I_R	6	ULN-2064B	$V_R = 50 \text{ V}$	—	50	μA
				$V_R = 50 \text{ V}, T_A = 70^\circ\text{C}$	—	100	μA
		ULN-2065B	$V_R = 80 \text{ V}$	—	50	μA	
			$V_R = 80 \text{ V}, T_A = 70^\circ\text{C}$	—	100	μA	
Clamp Diode Forward Voltage	V_F	7	Both	$I_F = 1.0 \text{ A}$	—	1.75	V
				$I_F = 1.5 \text{ A}$	—	2.0	V

ULN-2068B AND ULN-2069B

PARTIAL SCHEMATIC

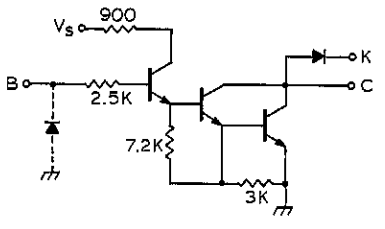

Dwg. No. A-10,354C

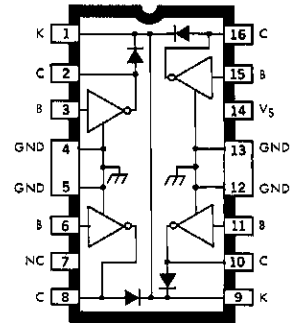

Dwg. No. A-10,310

ELECTRICAL CHARACTERISTICS AT +25°C, $V_s = 5.0$ V (unless otherwise noted)

Characteristic	Symbol	Test Fig.	Applicable Devices	Test Conditions	Limits		
					Min.	Max.	Units
Output Leakage Current	I_{CEX}	1	ULN-2068B	$V_{CE} = 50$ V	—	100	μ A
				$V_{CE} = 50$ V, $T_A = 70^\circ$ C	—	500	μ A
			ULN-2069B	$V_{CE} = 80$ V	—	100	μ A
				$V_{CE} = 80$ V, $T_A = 70^\circ$ C	—	500	μ A
Output Sustaining Voltage	$V_{CE(SUS)}$	2	ULN-2068B	$I_C = 100$ mA, $V_{IN} = 0.4$ V	35	—	V
			ULN-2069B	$I_C = 100$ mA, $V_{IN} = 0.4$ V	50	—	V
Collector-Emitter Saturation Voltage	$V_{CE(SAT)}$	3	Both	$I_C = 500$ mA, $I_{IN} = 2.75$ V	—	1.1	V
				$I_C = 750$ mA, $I_{IN} = 2.75$ V	—	1.2	V
				$I_C = 1.0$ A, $I_{IN} = 2.75$ V	—	1.3	V
				$I_C = 1.25$ A, $I_{IN} = 2.75$ V	—	1.4	V
		ULN-2069B	$I_C = 1.5$ A, $I_{IN} = 2.75$ V	—	1.5	V	
Input Current	$I_{IN(ON)}$	4	Both	$V_{IN} = 2.75$ V	—	550	μ A
				$V_{IN} = 3.75$ V	—	1000	μ A
Input Voltage	$V_{IN(ON)}$	5	ULN-2068B	$V_{CE} = 2.0$ V, $I_C = 1.25$ A	—	2.75	V
			ULN-2069B	$V_{CE} = 2.0$ V, $I_C = 1.5$ A	—	2.75	V
Supply Current	I_S	8	Both	$I_C = 500$ mA, $V_{IN} = 2.75$ V	—	6.0	mA
Turn-On Delay	t_{PLH}	—	Both	$0.5 E_{in}$ to $0.5 E_{out}$	—	1.0	μ s
Turn-Off Delay	t_{PHL}	—	Both	$0.5 E_{in}$ to $0.5 E_{out}$, $I_C = 1.25$ A	—	1.5	μ s
Clamp Diode Leakage Current	I_R	6	ULN-2068B	$V_R = 50$ V	—	50	μ A
				$V_R = 50$ V, $T_A = 70^\circ$ C	—	100	μ A
		ULN-2069B	$V_R = 80$ V	—	50	μ A	
			$V_R = 80$ V, $T_A = 70^\circ$ C	—	100	μ A	
Clamp Diode Forward Voltage	V_F	7	Both	$I_F = 1.0$ A	—	1.75	V
				$I_F = 1.5$ A	—	2.0	V

4

ULN-2074B AND ULN-2075B

PARTIAL SCHEMATIC

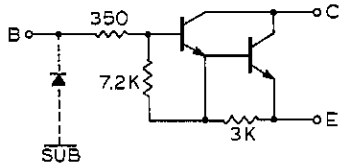

Dwg. No. A-10,366B

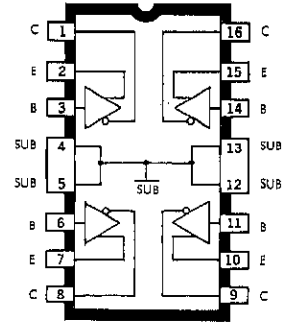

Dwg. No. A-9768A

(SIMILAR TO ULN-2064B AND ULN-2065B)

ELECTRICAL CHARACTERISTICS at +25°C (unless otherwise noted)

Characteristic	Symbol	Test Fig.	Applicable Devices	Test Conditions	Limits		
					Min.	Max.	Units
Output Leakage Current	I_{CEX}	1	ULN-2074B	$V_{CE} = 50 \text{ V}$	—	100	μA
				$V_{CE} = 50 \text{ V}, T_A = 70^\circ\text{C}$	—	500	μA
			ULN-2075B	$V_{CE} = 80 \text{ V}$	—	100	μA
				$V_{CE} = 50 \text{ V}, T_A = 70^\circ\text{C}$	—	500	μA
Output Sustaining Voltage	$V_{CE(SUS)}$	2	ULN-2074B	$I_C = 100 \text{ mA}, V_{IN} = 0.4 \text{ V}$	35	—	V
			ULN-2075B	$I_C = 100 \text{ mA}, V_{IN} = 0.4 \text{ V}$	50	—	V
Collector-Emitter Saturation Voltage	$V_{CE(SAT)}$	3	Both	$I_C = 500 \text{ mA}, I_B = 625 \mu\text{A}$	—	1.1	V
				$I_C = 750 \text{ mA}, I_B = 935 \mu\text{A}$	—	1.2	V
				$I_C = 1.0 \text{ A}, I_B = 1.25 \text{ mA}$	—	1.3	V
				$I_C = 1.25 \text{ A}, I_B = 2.0 \text{ mA}$	—	1.4	V
			ULN-2075B	$I_C = 1.5 \text{ A}, I_B = 2.25 \text{ mA}$	—	1.5	V
Input Current	$I_{IN(ON)}$	4	Both	$V_{IN} = 2.4 \text{ V}$	1.4	4.3	mA
				$V_{IN} = 3.75 \text{ V}$	3.3	9.6	mA
Input Voltage	$V_{IN(ON)}$	5	Both	$V_{CE} = 2.0 \text{ V}, I_C = 1.0 \text{ A}$	—	2.0	V
			ULN-2074B	$V_{CE} = 2.0 \text{ V}, I_C = 1.25 \text{ A}$	—	2.5	V
			ULN-2075B	$V_{CE} = 2.0 \text{ V}, I_C = 1.5 \text{ A}$	—	2.5	V
Turn-On Delay	t_{PLH}	—	Both	$0.5 E_{in}$ to $0.5 E_{out}$	—	1.0	μs
Turn-Off Delay	t_{PHL}	—	Both	$0.5 E_{in}$ to $0.5 E_{out}$	—	1.5	μs

TEST FIGURES

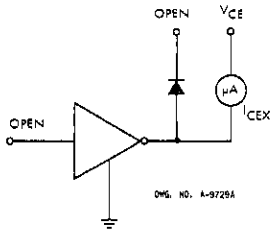

Figure 1

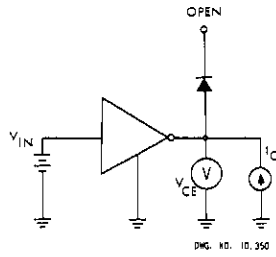

Figure 2

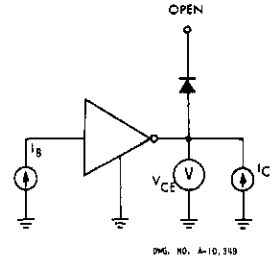

Figure 3

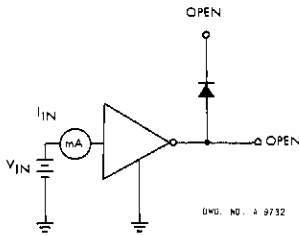

Figure 4

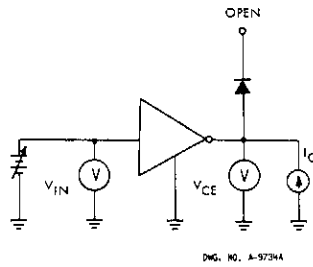

Figure 5

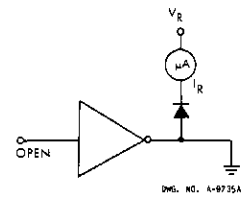

Figure 6

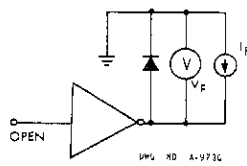

Figure 7

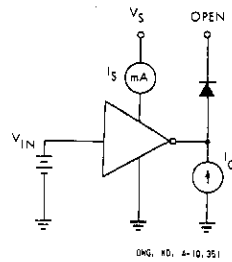
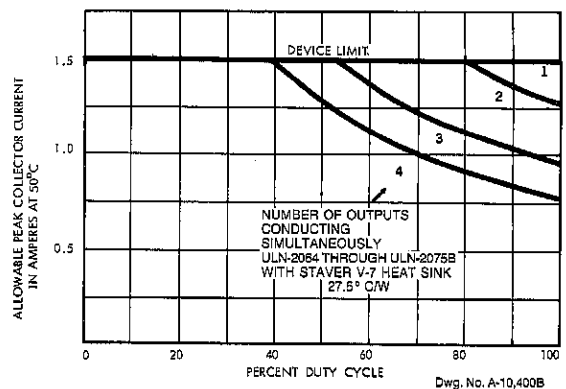
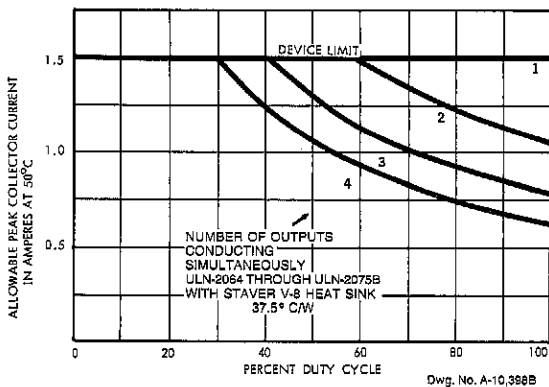
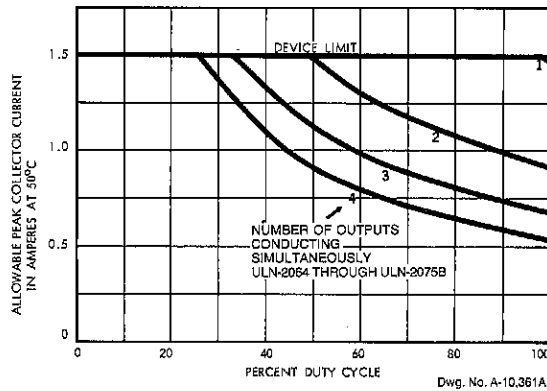
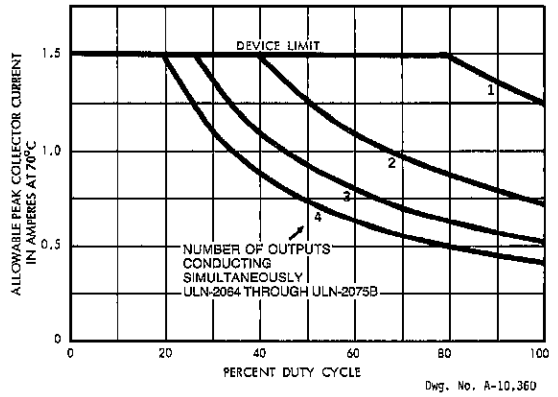
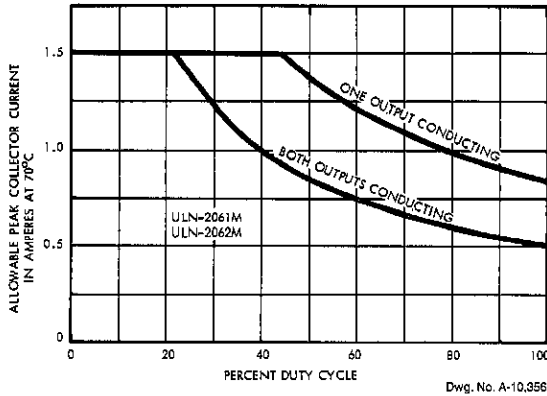

Figure 8

4

**ULN-2061M THROUGH ULN-2075B
1.5 A DARLINGTON SWITCHES**

PEAK COLLECTOR CURRENT AS A FUNCTION OF DUTY CYCLE



**PEAK COLLECTOR CURRENT
AS A FUNCTION OF DUTY CYCLE (Continued)**

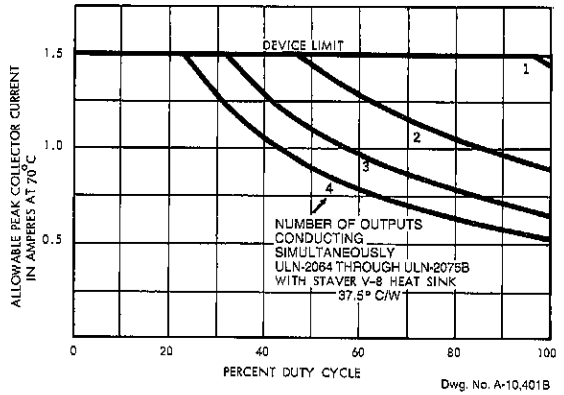
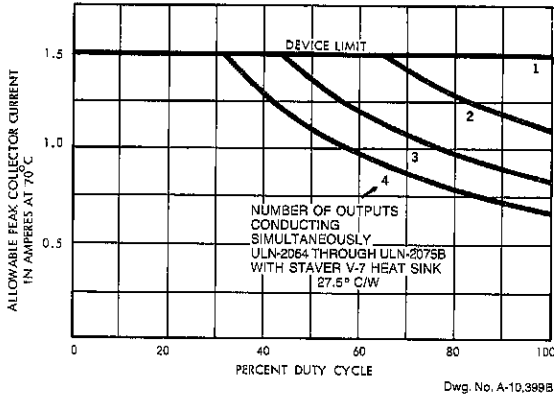

4

COLLECTOR CURRENT AS A FUNCTION OF INPUT CURRENT AT +25°C

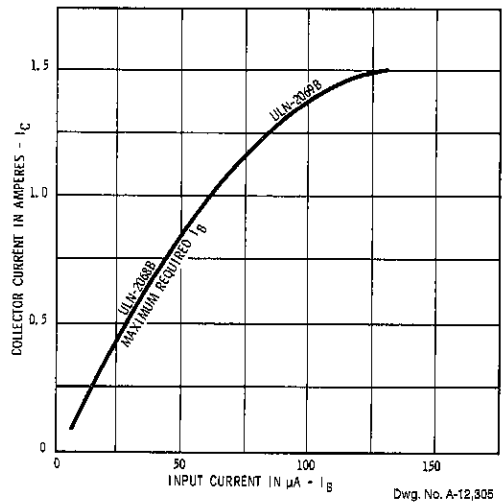
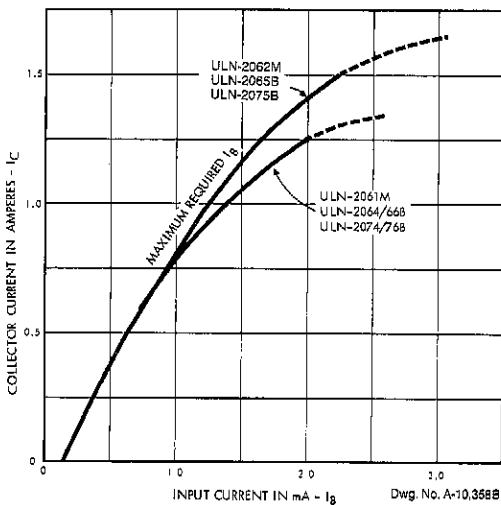

INPUT CURRENT AS A FUNCTION OF INPUT VOLTAGE AT +25°C

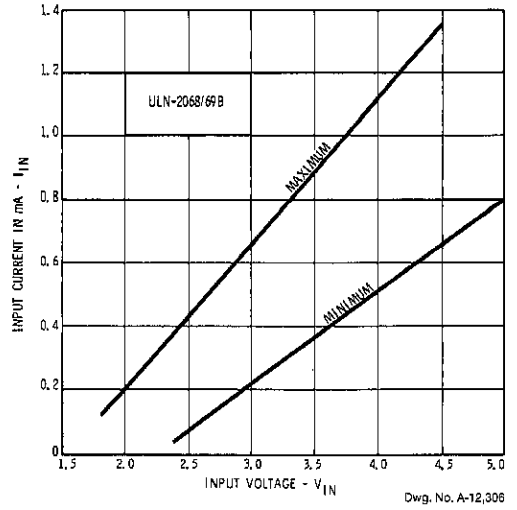
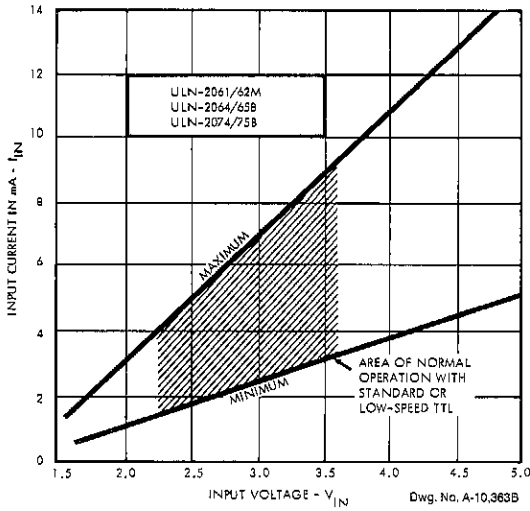

TYPICAL APPLICATION

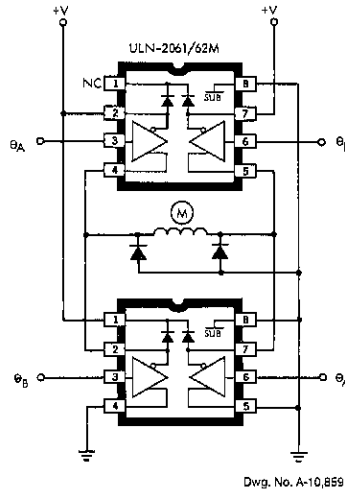

BIDIRECTIONAL MOTOR CONTROL

TYPICAL APPLICATIONS (Continued)

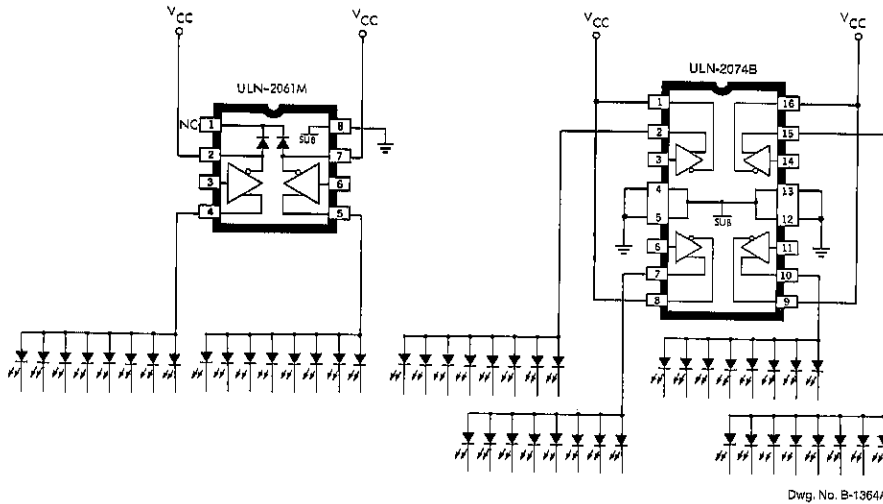

COMMON-ANODE LED DRIVERS

(Series UDN-2980A devices can be used in similar applications at currents of up to 500 mA)

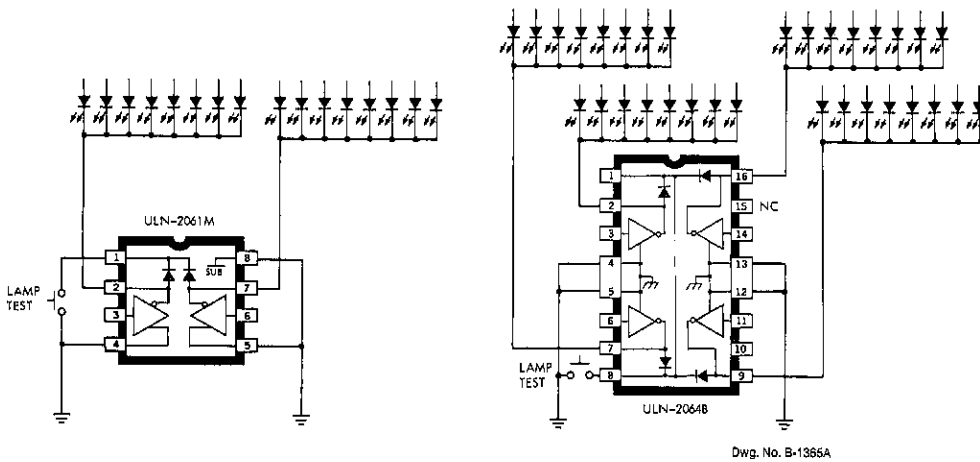

COMMON-CATHODE LED DRIVERS

(Type ULN-2068B is also applicable)

UDN-2540B

QUAD-NAND GATE POWER DRIVER

FEATURES

- 1.5 A Output Current
- Output Voltage to 60 V
- Integral Transient-Suppression Diodes
- Efficient Input/Output Pin Structure
- TTL, CMOS, PMOS, NMOS Compatible

Combining NAND logic gates and high-current bipolar outputs, the UDN-2540B power and relay driver provides interface between low-level signal-processing circuits and power loads to 350 W. Each of the four independent outputs of this device can sink up to 1.5 A in the ON state. In the OFF state the drivers will withstand at least 60 V. Transient-suppression clamp diodes and a minimum 35 V output sustaining voltage allow their use with many inductive loads.

Typical applications include relays, solenoids, and dc stepping motors. It can also be used to drive high-current incandescent lamps, LEDs, and heaters. In display applications, the diodes can be used to perform the "lamp test" function.

Inputs are compatible with most TTL, DTL, LSTTL, and 5 V or 12 V CMOS and PMOS logic.

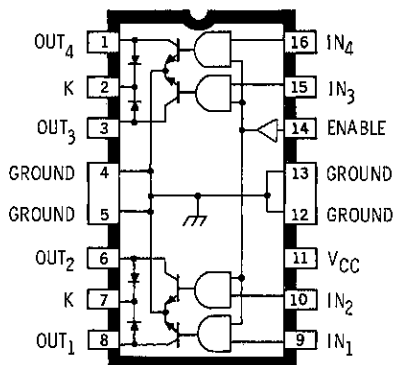

Dwg. No. A-11.561

Each of the four outputs is recommended for continuous load currents to 1.25 A. Outputs can be paralleled for higher load currents.

The UDN-2540B is supplied in a 16-pin dual-in-line package with heat-sink contact tabs. This configuration allows attachment of an inexpensive heat sink and fits a standard integrated circuit socket or printed wiring board layout.

ABSOLUTE MAXIMUM RATINGS

at +25°C Free-Air Temperature

Output Voltage, V_{CE}	60 V
Output Current, I_{OUT}	1.5 A
Supply Voltage, V_{CC}	18 V
Input Voltage, V_{IN}	18 V
Power Dissipation, P_D (Each Driver)	2.5 W
(Total Package)	See Graph
Operating Temperature Range, T_A	-20°C to +85°C
Storage Temperature Range, T_S	-55°C to +150°C

ELECTRICAL CHARACTERISTICS at $T_A = +25^\circ\text{C}$, $T_{TAB} = +70^\circ\text{C}$, $V_{CC} = 4.75\text{ V to }12.6\text{ V}$ (unless otherwise noted)

Characteristic	Symbol	Test Conditions	Limits		
			Min.	Max.	Units
Output Leakage Current	I_{CEX}	$V_{OUT} = 60\text{ V}$, $V_{IN} = 0.7\text{ V}$, $V_{ENABLE} = 2.0\text{ V}$	—	100	μA
		$V_{OUT} = 60\text{ V}$, $V_{IN} = 2.0\text{ V}$, $V_{ENABLE} = 0.7\text{ V}$	—	100	μA
Output Sustaining Voltage	$V_{CE(SUS)}$	$I_{OUT} = 100\text{ mA}$, $V_{IN} = V_{ENABLE} = 0.7\text{ V}$	35	—	V
Output Saturation Voltage	$V_{CE(SAT)}$	$I_{OUT} = 250\text{ mA}$, $V_{IN} = V_{ENABLE} = 2.0\text{ V}$	—	1.0	V
		$I_{OUT} = 500\text{ mA}$, $V_{IN} = V_{ENABLE} = 2.0\text{ V}$	—	1.1	V
		$I_{OUT} = 750\text{ mA}$, $V_{IN} = V_{ENABLE} = 2.0\text{ V}$	—	1.25	V
		$I_{OUT} = 1.0\text{ A}$, $V_{IN} = V_{ENABLE} = 2.0\text{ V}$	—	1.4	V
		$I_{OUT} = 1.25\text{ A}$, $V_{IN} = V_{ENABLE} = 2.0\text{ V}$	—	1.6	V
Input Voltage	Logic 1	$V_{IN(1)}$ or $V_{ENABLE(1)}$	2.0	—	V
	Logic 0	$V_{IN(0)}$ or $V_{ENABLE(0)}$	—	0.7	V
Input Current	Logic 1	$V_{IN(1)}$ or $V_{ENABLE(1)} = 2.0\text{ V}$	—	20	μA
	Logic 0	$V_{IN(0)}$ or $V_{ENABLE(0)} = 0.4\text{ V}$	—	-200	μA
Input Clamp Voltage	V_{IK}	I_{IN} or $I_{ENABLE} = -10\text{ mA}$	—	-1.5	V
Total Supply Current	I_{CC}	$V_{IN}^* = V_{ENABLE} = 2.0\text{ V}$, $V_{CC} = 5.0\text{ V}$, Outputs Open	—	8.0	mA
		$V_{IN}^* = V_{ENABLE} = 2.0\text{ V}$, $V_{CC} = 15\text{ V}$, Outputs Open	—	33	mA
		$V_{IN}^* = V_{ENABLE} = 0.7\text{ V}$, $V_{CC} = 5.0\text{ V}$	—	2.0	mA
		$V_{IN}^* = V_{ENABLE} = 0.7\text{ V}$, $V_{CC} = 15\text{ V}$	—	7.0	mA
Clamp Diode Forward Voltage	V_F	$I_F = 1.0\text{ A}$	—	2.1	V
		$I_F = 1.25\text{ A}$	—	2.5	V
Clamp Diode Leakage Current	I_R	$V_R = 60\text{ V}$, $V_{IN} = V_{ENABLE} = 2.0\text{ V}$, $D_1 + D_2$ or $D_3 + D_4$	—	100	μA

4

*All inputs simultaneously, all other tests are performed with each input tested separately.

ALLOWABLE AVERAGE PACKAGE POWER DISSIPATION AS A FUNCTION OF TEMPERATURE

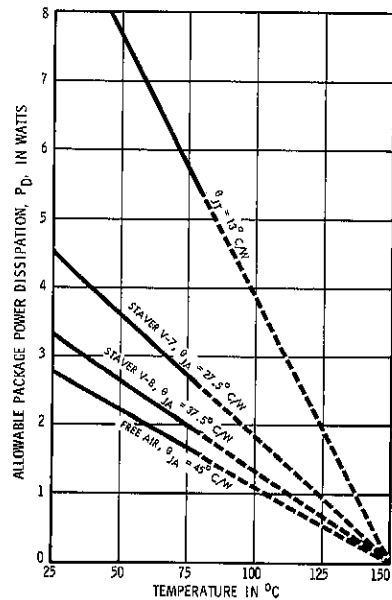

Dwg. No. A-11,793B

APPLICATIONS

Typical applications for this device include driving incandescent lamps and dc stepper motors. Lamps with steady-state current ratings up to 150 mA can be driven without current limiting or warming resistors (assumes 1.5 A peak in-rush). The internal diodes can be used to perform the "lamp test" function as shown. Bifilar (unipolar) stepper motors can be driven directly. The internal transient-suppression diodes prevent damage to the output transistor from positive high-voltage inductive spikes as the output switches OFF.

INCANDESCENT LAMP DRIVER

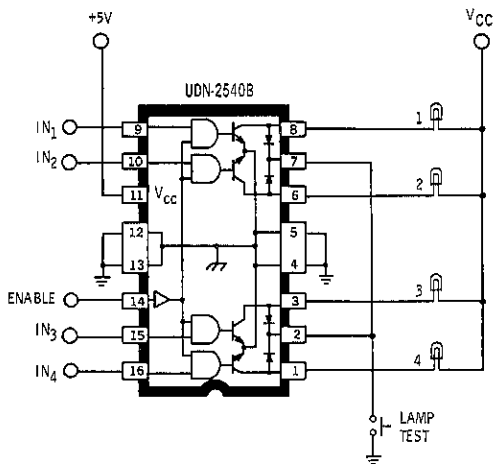

Dwg. No. A-12,048A

STEPPER-MOTOR DRIVER

INPUT WAVEFORMS

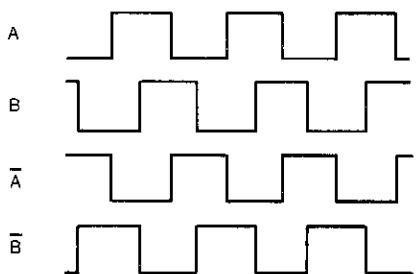

Dwg. No. A-11,795

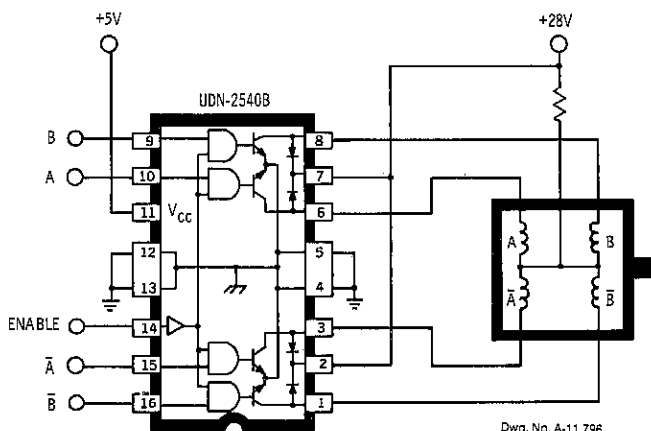

Dwg. No. A-11,796

UDN-2545B UNIVERSAL QUAD DRIVER

FEATURES

- Output Current of 2 A
- 80 V Min. Output Breakdown
- 40 V Output Sustaining Voltage
- PMOS, CMOS, TTL Compatible
- Built-in Thermal Shutdown
- Output Transient Protection
- CHIP ENABLE for Microprocessor Control
- Under-Voltage Protection

The UDN-2545B is a four-channel high-current, high-voltage integrated circuit designed to provide the interface between stepper motors and microprocessor or logic motor control circuitry. The UDN-2545B will accept most standard logic signal inputs and provide motor drive current to both positive and negative supply rails.

The UDN-2545B is capable of sinking up to 2.5 A and maintaining an output OFF voltage of 80 volts. This device incorporates some unique features such as under-voltage protection, thermal shutdown, and CHIP ENABLE control. The under-voltage protection guards against supply line transients and has

built-in hysteresis. The thermal shutdown with hysteresis is to guard against damage to the device. CHIP ENABLE is especially good for use in microprocessor control. All outputs have clamp diodes for suppression of inductive loads.

The UDN-2545B is supplied in a 16 pin plastic dual in-line package with heat-sink contact tabs. A copper-alloy lead frame provides maximum power dissipation using standard cooling methods. This lead configuration facilitates attachment of external heat sinks for increased power dissipation with standard IC sockets and printed wiring boards.

FUNCTIONAL BLOCK DIAGRAM

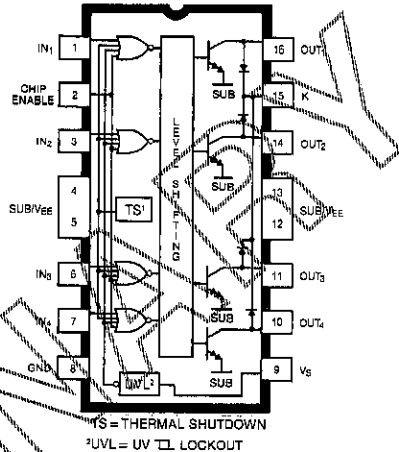
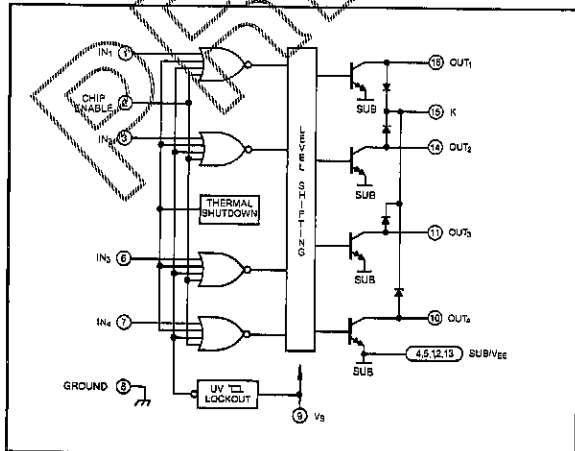

4

ABSOLUTE MAXIMUM RATINGS at $T_A = +25^\circ\text{C}$

Output Voltage, V_{CE}	80 V
Emitter Supply Voltage, V_{EE}	-25 V
Logic Supply Voltage, V_S	20 V
Output Current, I_{OUT}	2.5 A
Input Voltage, V_{IN}	25 V
Package Power Dissipation, P_D	2.77 W*
Operating Temperature Range, T_A	-20°C to +85°C
Storage Temperature Range, T_S	-55°C to +150°C

*Derate at the Rate of 22.2 mW/°C above $T_A = 25^\circ\text{C}$.

**UDN-2545B
UNIVERSAL QUAD DRIVER**

ELECTRICAL CHARACTERISTICS at $T_A = +25^\circ\text{C}$, $V_S = 5\text{ V to }15\text{ V}$, $V_{EE} = 0\text{ V}$ (unless otherwise noted)

Characteristic	Symbol	Test Conditions	Limits		
			Min.	Max.	Units
Output Leakage Current	I_{CEX}	$V_{OUT} = 80\text{ V}$, $V_{IN} = 2.0\text{ V}$, Other Inputs = 0 V	—	500	μA
Output Sustaining Voltage	$V_{CE(SUS)}$	$I_{OUT} = 2\text{ A}$, Inputs = 5.0 V, L = 3 mH	40	—	V
Output Saturation Voltage*	$V_{CE(SAT)}$	$I_{OUT} = 2\text{ A}$, Inputs = 0 V	—	2.2	V
Clamp Diode Leakage Current	I_R	$V_R = 80\text{ V}$	—	50	μA
Clamp Diode Forward Voltage	V_F	$I_F = 2\text{ A}$	—	2.5	V
Input Current	$I_{IN(ON)}$	$V_{IN} = 0.8\text{ V}$	—	-250	μA
	$I_{IN(OFF)}$	$V_{IN} = V_S$	—	50	μA
Supply Current	$I_{S(ON)}$	All Inputs = 0.8 V, $V_S = 5.0\text{ V}$	—	65	mA
		All Inputs = 0.8 V, $V_S = 15\text{ V}$	—	70	mA
	$I_{S(OFF)}$	All Inputs = 5.0 V, $V_S = 5.0\text{ V}$	—	20	mA
		All Inputs = 15 V, $V_S = 15\text{ V}$	—	30	mA

*Pulse Test

STEPPER MOTOR APPLICATION

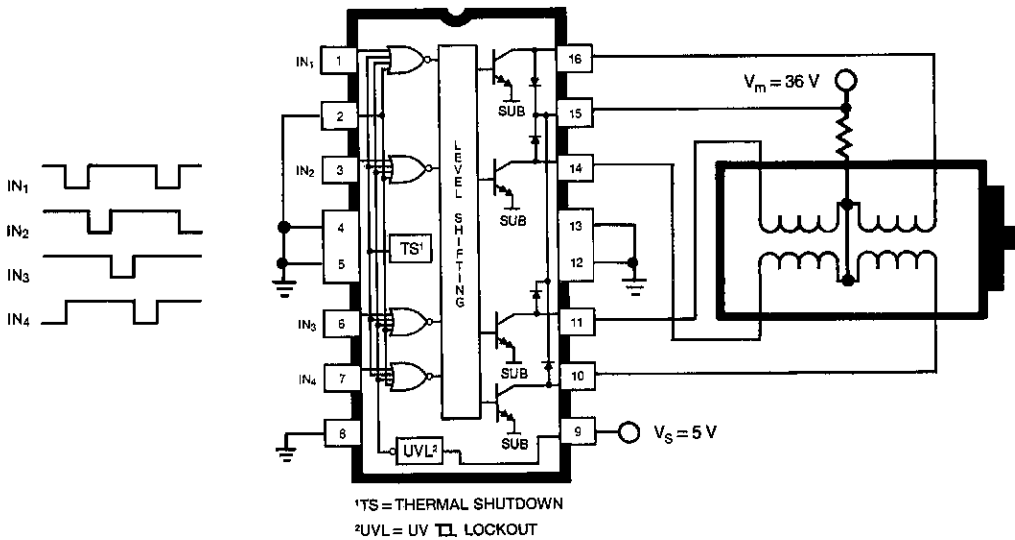

UDN-2841B AND UDN-2845B QUAD DARLINGTON 1.5 A DRIVERS

FEATURES

- Inputs Compatible with DTL, TTL, LS TTL, CMOS
- -50 V Darlington Outputs
- Current-Sink or Sink-and-Source Combination
- 16-Pin Dual In-Line Plastic Package

THIS PAIR OF QUAD DARLINGTON switches is designed for high-current, high-voltage peripheral driver applications. They provide solutions to interface problems involving electronic discharge printers, d-c motor drive (bipolar or unipolar), telephone relays, PIN diodes, LEDs, and other high-current loads operating with negative voltage supplies.

Type UDN-2841B is for current-sink applications in which the load is connected to ground. The outputs switch the negative supply. The input PNP transistor in each driver serves as a level translator. The first NPN stage provides current gain to drive the Darlington-pair outputs.

Type UDN-2845B is a current-sink, current-source combination in a single dual in-line plastic package. It can be used in bipolar switching applications in which neither end of the load is at ground potential.

Types UDN-2841 and UDN-2845B are intended for use with 5 V TTL, Schottky TTL, DTL, and CMOS logic. Both drivers reduce component count, lower system costs, and reduce circuit and board complexity.

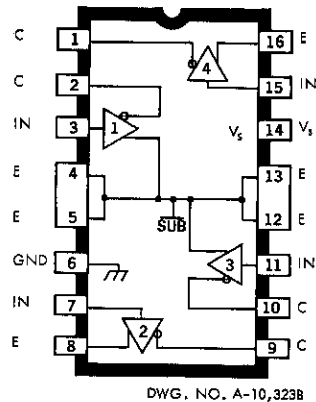

4

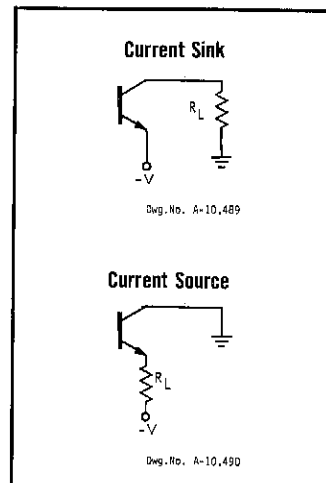

**ABSOLUTE MAXIMUM RATINGS
at +25°C Free-Air Temperature
For Single Darlington Output
(Unless Otherwise Noted)**

Output Voltage, $V_{CE(OFF)}$	50 V
Output Sustaining Voltage, $V_{CE(SUS)}$	35 V
Substrate Voltage, V_{SUB}	- 50 V
Continuous Output Current, I_{OUT}	1.75 A
Supply Voltage, V_S	10 V
Input Voltage, V_{IN}	10 V
Power Dissipation, P_D (one output)	See Graph
Operating Temperature Range, T_A	- 20°C to + 85°C
Storage Temperature Range, T_S	- 55°C to + 150°C

**SCHEMATIC
(Each Driver)**

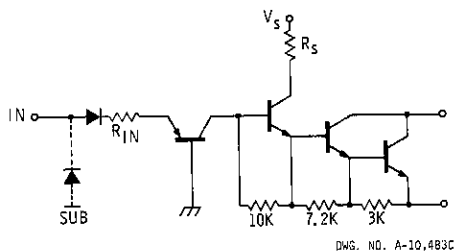

Type Number	Resistor Values in k Ω			
	Amplifier 1 & 3		Amplifier 2 & 4	
	R_{IN}	R_S	R_{IN}	R_S
UDN-2841B	3.3	15	3.3	15
UDN-2845B	3.3	15	3.3	1

NOTE: The substrate terminals must be tied to the most negative point in the external circuit to maintain isolation between transistors and to provide for normal device operation.

**ALLOWABLE POWER DISSIPATION
AS A FUNCTION OF TEMPERATURE**

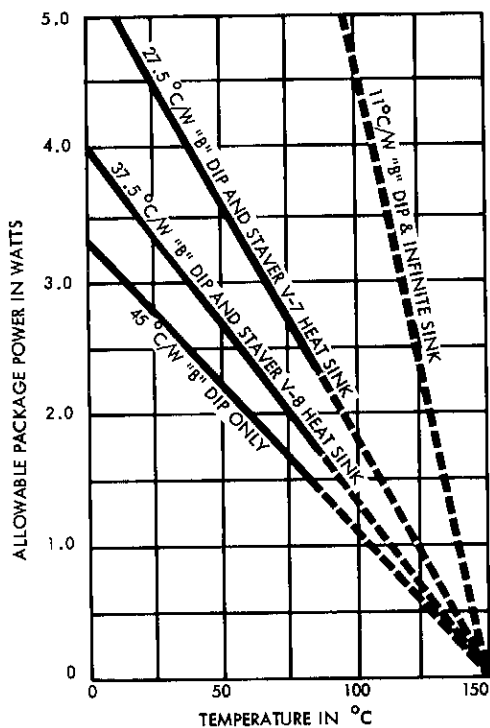

DWG. NO. A-10,488C

ELECTRICAL CHARACTERISTICS at $T_A = +25^\circ\text{C}$ (unless otherwise noted)

Characteristic	Symbol	Test Conditions	Limits			Units
			Min.	Typ.	Max.	
Output Leakage Current	I_{CEX}	$V_{EE} = -50\text{V}, V_{IN} = 0.4\text{V}, T_A = 25^\circ\text{C}$	—	—	100	μA
		$V_{EE} = -50\text{V}, V_{IN} = 0.4\text{V}, T_A = 70^\circ\text{C}$	—	—	500	μA
Output Sustaining Voltage	$V_{CE(SUS)}$	$V_{EE} = -50\text{V}, V_{IN} = 0.4\text{V}, I_{OUT} = 100\text{mA}$	35	50	—	V
Output Saturation Voltage	$V_{CE(SAT)}$	$I_{OUT} = 500\text{mA}$	—	—	1.1	V
		$I_{OUT} = 1.0\text{A}$ (Note 1)	—	—	1.4	V
		$I_{OUT} = 1.5\text{A}$ (Note 1)	—	—	1.6	V
Input Current	$I_{IN(ON)}$	$I_{OUT} = 500\text{mA}, V_{IN} = 2.4\text{V}$	—	300	500	μA
Input Voltage (Note 1)	$V_{IN(ON)}$	$I_{OUT} = 1.5\text{A}$	—	—	2.4	V
Supply Current (Note 1)	I_S	$I_{OUT} = 500\text{mA}$, UDN-2841B, UDN-2845B (Note 2)	—	2.5	3.75	mA
		$I_{OUT} = 500\text{mA}$, UDN-2845B (Note 3)	—	3.3	7.5	mA
Turn-On Delay	$t_{pd(ON)}$	$R_L = 39\Omega, 0.5 V_{IN}$ to $0.5 V_{OUT}$	—	—	2.0	μs
Turn-Off Delay	$t_{pd(OFF)}$	$R_L = 39\Omega, 0.5 V_{IN}$ to $0.5 V_{OUT}$	—	—	5.0	μs

NOTES:

1. Each driver tested separately.
2. Drivers 1 & 3 (sink drivers) only, $V_S = 0\text{V}, V_{EE} = -40\text{V}$.
3. Drivers 2 & 4 (source drivers) only, $V_S = 5\text{V}, V_{EE} = -40\text{V}$.

4

TEST CIRCUITS

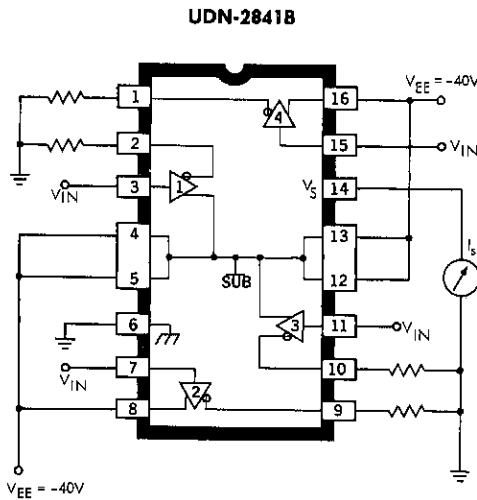

DWG. NO. A-10,487A

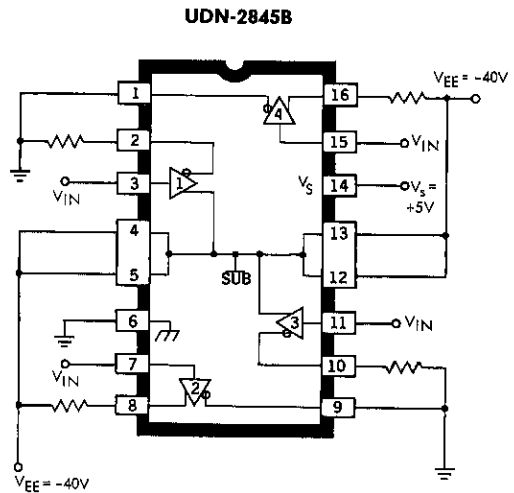

DWG. NO. A-10,484A

ALLOWABLE OUTPUT CURRENT AS A FUNCTION OF DUTY CYCLE

WITHOUT HEAT SINK

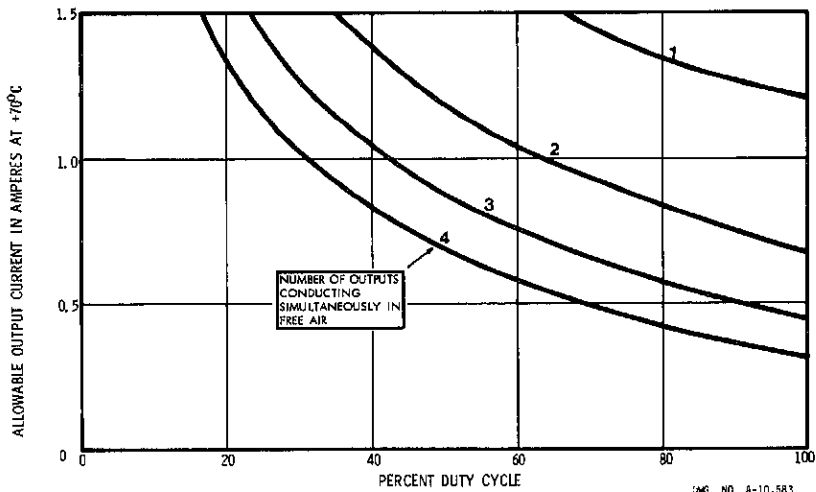

WITH STAVER V-7 HEAT SINK

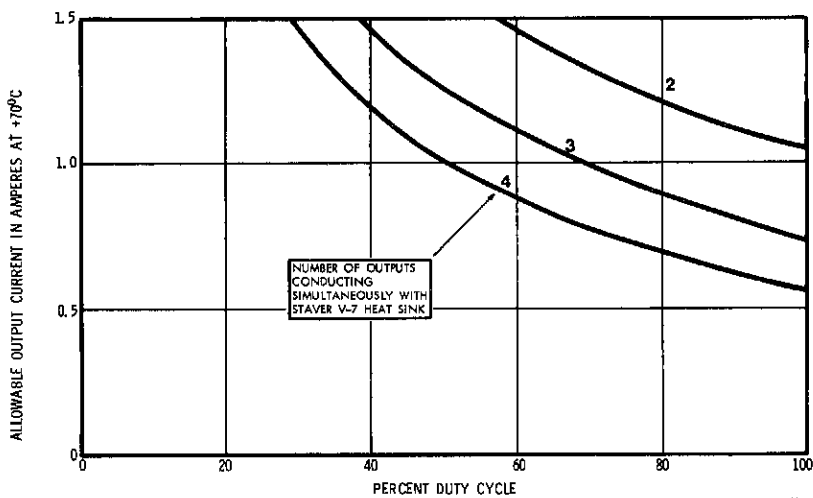

OUTPUT-STAGE TRANSIENT PROTECTION

When switching inductive loads, the output transistors of UDN-2841B and UDN-2845B drivers should be protected by a suitable clamping technique. The simplest approach is to clamp each output with a discrete diode, as shown in Figures 1 and 2.

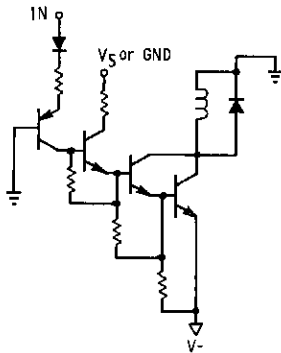

DWG. NO. A-11,790A

Figure 1
UDN-2841B

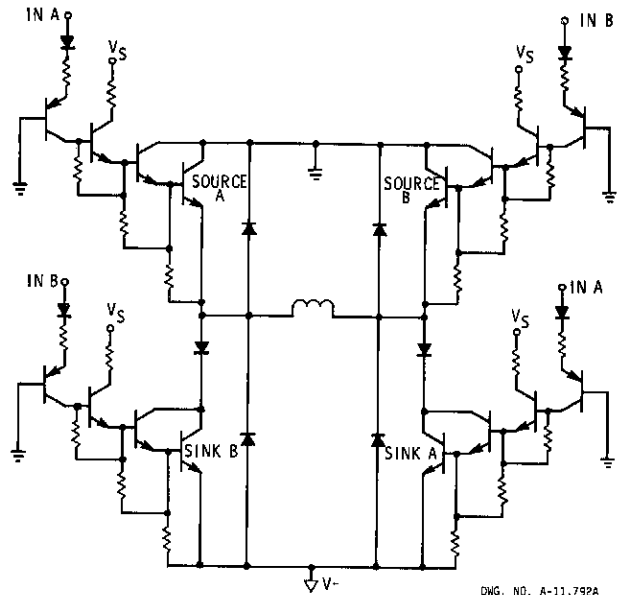

DWG. NO. A-11,792A

Figure 2
UDN-2845B

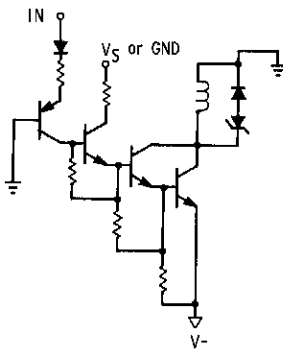

DWG. NO. A-11,787A

Figure 3
UDN-2841B

For improved turnoff, a combination diode/Zener diode scheme can be used. The Zener diode in the clamp circuit of Figure 3 allows the flyback voltage to rise above the supply voltage, speeding turnoff of the load. An appropriate resistor can be substituted for the Zener diode. With a 1 A load, substitution of a 15Ω resistor results in operation similar to that of the Zener diode circuit.

TYPICAL APPLICATIONS

BIPOLAR MOTOR DRIVER

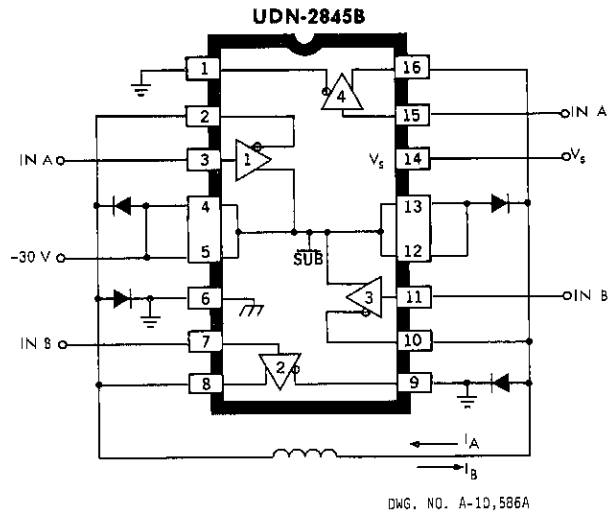

ELECTROSENSITIVE PRINTER INTERFACE

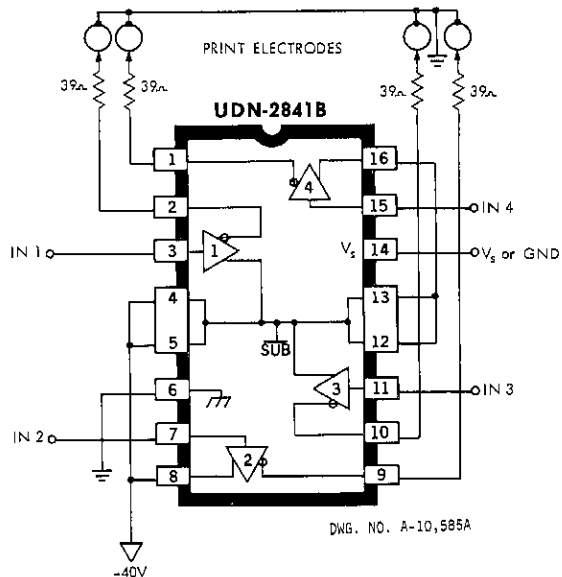

UDN-2878W AND UDN-2879W QUAD HIGH-CURRENT DARLINGTON SWITCHES

FEATURES

- Output Currents to 4 A
- Output Voltages to 80 V
- Loads to 1280 W
- TTL, DTL, or CMOS Compatible Inputs
- Internal Clamp Diodes
- Plastic Single In-Line Package
- Heat-Sink Tab

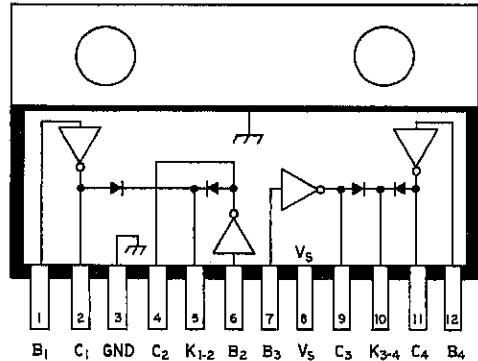

DWG. NO. A-11,974

THESE QUAD DARLINGTON ARRAYS are designed to serve as interface between low-level logic and peripheral power devices such as solenoids, motors, incandescent displays, heaters, and similar loads of up to 320 W per channel. Both integrated circuits include transient-suppression diodes that enable use with inductive loads. The input logic is compatible with most TTL, DTL, LS TTL, and 5 V CMOS logic.

Type UDN-2878W and UDN-2879W 4 A arrays are identical except for output-voltage ratings. The former is rated for operation to 50 V (35 V sustaining), while the latter has a minimum output breakdown rating of 80 V (50 V_s sustaining). The

economical Type UDN-2878W-2 and Type UDN-2879W-2 are recommended for applications requiring load currents of 3 A or less. These less expensive devices are identical to the basic parts except for the maximum allowable load-current rating.

For maximum power-handling capability, all drivers are supplied in a 12-pin single in-line power-tab package. The tab is at ground potential and needs no insulation. External heat sinks are usually required for proper operation of these devices.

Device	Output Voltage	Sustaining Voltage	Output Current
UDN-2878W	50 V	35 V	4 A
UDN-2878W-2	50 V	35 V	3 A
UDN-2879W	80 V	50 V	4 A
UDN-2879W-2	80 V	50 V	3 A

4

**UDN-2878W AND UDN-2879W
 QUAD HIGH-CURRENT DARLINGTON SWITCHES**

**ABSOLUTE MAXIMUM RATINGS
 at +25°C Free-Air Temperature
 for any driver
 (unless otherwise noted)**

Output Voltage, V_{CEK} (UDN-2878W & UDN-2878W-2)	50 V
(UDN-2879W & UDN-2879W-2)	80 V
Output Current, I_C (UDN-2878W & UDN-2879W)	5.0 A
(UDN-2878W-2 & UDN-2879W-2)	4.0 A
Input Voltage, V_{IN}	15 V
Input Current, I_{IN}	25 mA
Supply Voltage, V_S	10 V
Total Package Power Dissipation, P_D	See Graph
Operating Ambient Temperature Range, T_A	-20°C to +85°C
Storage Temperature Range, T_S	-55°C to +150°C

**ALLOWABLE AVERAGE PACKAGE POWER DISSIPATION
 AS A FUNCTION OF TEMPERATURE**

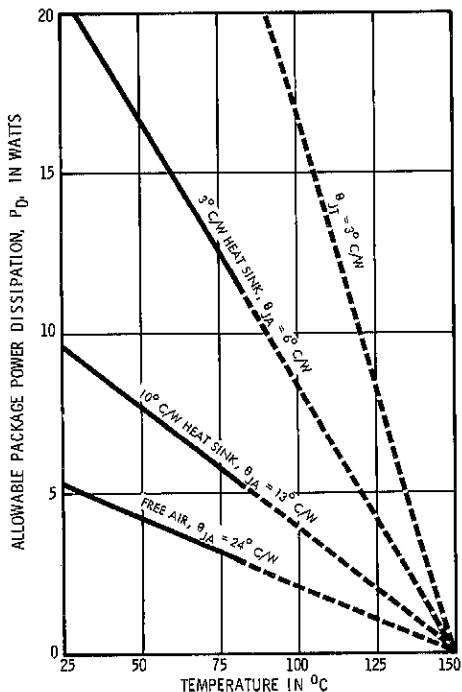

Dwg. No. A-11,794

**PARTIAL SCHEMATIC
 One of 4 Drivers**

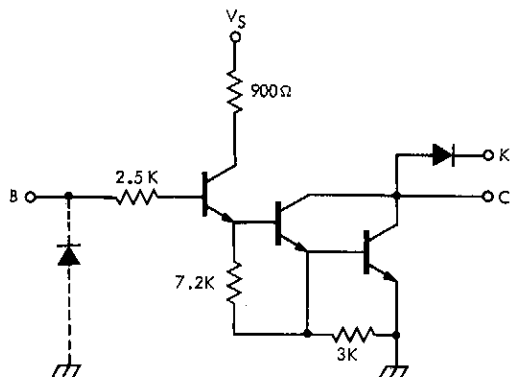

DWG. NO. A-12,037

ELECTRICAL CHARACTERISTICS at $V_s = 5.0\text{ V}$, $T_A = +25^\circ\text{C}$ (unless otherwise noted)

Characteristic	Symbol	Test Fig.	Applicable Devices	Test Conditions	Limits		
					Min.	Max.	Units
Output Leakage Current	I_{CEX}	1	UDN-2878W/W-2	$V_{CE} = 50\text{ V}$	—	100	μA
				$V_{CE} = 50\text{ V}$, $T_A = +70^\circ\text{C}$	—	500	μA
			UDN-2879W/W-2	$V_{CE} = 80\text{ V}$	—	100	μA
				$V_{CE} = 80\text{ V}$, $T_A = +70^\circ\text{C}$	—	500	μA
Output Sustaining Voltage	$V_{CE(SUS)}$	2	UDN-2878W/W-2	$I_C = 100\text{ mA}$, $V_{IN} = 0.4\text{ V}$	35	—	V
			UDN-2879W/W-2	$I_C = 100\text{ mA}$, $V_{IN} = 0.4\text{ V}$	50	—	V
Collector-Emitter Saturation Voltage	$V_{CE(SAT)}$	2	All	$I_C = 500\text{ mA}$, $V_{IN} = 2.75\text{ V}$	—	1.1	V
				$I_C = 1.0\text{ A}$, $V_{IN} = 2.75\text{ V}$	—	1.3	V
				$I_C = 2.0\text{ A}$, $V_{IN} = 2.75\text{ V}$	—	1.5	V
				$I_C = 3.0\text{ A}$, $V_{IN} = 2.75\text{ V}$	—	1.9	V
			UDN-2878/2879W	$I_C = 4.0\text{ A}$, $V_{IN} = 2.75\text{ V}$	—	2.2	V
Input Current	I_{IN}	3	All	$V_{IN} = 2.75\text{ V}$	—	550	μA
				$V_{IN} = 3.75\text{ V}$	—	1000	μA
Input Voltage	$V_{IN(ON)}$	4	All	$V_{CE} = 2.2\text{ V}$, $I_C = 3.0\text{ A}$	—	2.75	V
			UDN-2878/2879W	$V_{CE} = 2.2\text{ V}$, $I_C = 4.0\text{ A}$	—	2.75	V
Supply Current per Driver	I_S	7	All	$I_C = 500\text{ mA}$, $V_{IN} = 2.75\text{ V}$	—	6.0	mA
Turn-On Delay	t_{PLH}	—	All	$0.5 E_{in}$ to $0.5 E_{out}$	—	1.0	μs
Turn-Off Delay	t_{PHL}	—	All	$0.5 E_{in}$ to $0.5 E_{out}$, $I_C = 3.0\text{ A}$	—	1.5	μs
Clamp Diode Leakage Current	I_R	5	All	$V_R = 50\text{ V}$	—	50	μA
				$V_R = 50\text{ V}$, $T_A = +70^\circ\text{C}$	—	100	μA
			UDN-2879W/W-2	$V_R = 80\text{ V}$	—	50	μA
				$V_R = 80\text{ V}$, $T_A = +70^\circ\text{C}$	—	100	μA
Clamp Diode Forward Voltage	V_F	6	All	$I_F = 3.0\text{ A}$	—	2.5	V
			UDN-2878/2879W	$I_F = 4.0\text{ A}$	—	3.0	V

CAUTION: High-current tests are pulse tests or require heat sinking.

TEST FIGURES

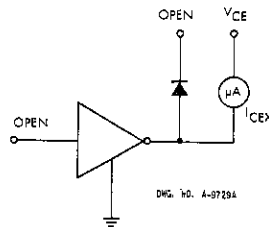

Figure 1

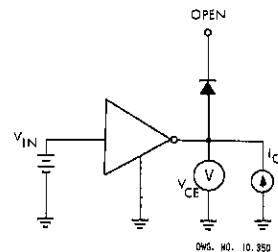

Figure 2

TEST FIGURES (Continued)

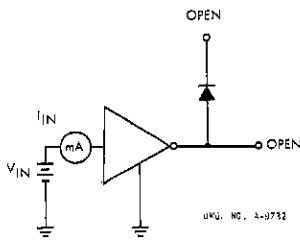

Figure 3

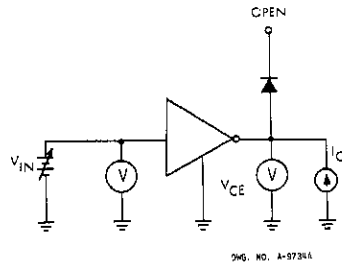

Figure 4

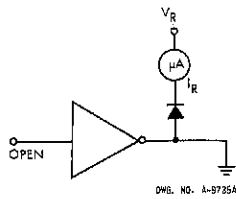

Figure 5

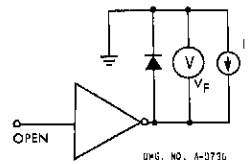

Figure 6

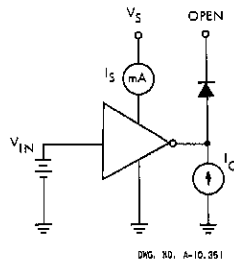
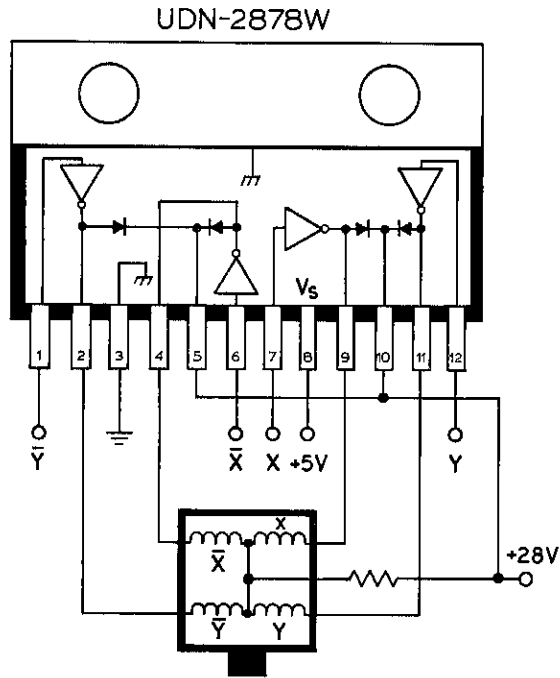

Figure 7

TYPICAL APPLICATIONS

STEPPER-MOTOR DRIVER



DWG. NO. A-11,975

INPUT WAVEFORMS

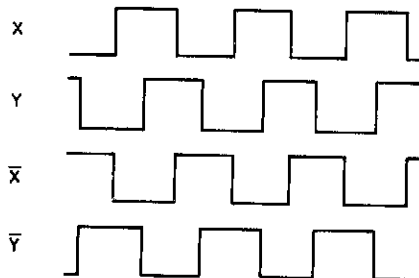

Dwg. No. A-11,795

4

TYPICAL APPLICATIONS

PRINT-HAMMER DRIVER

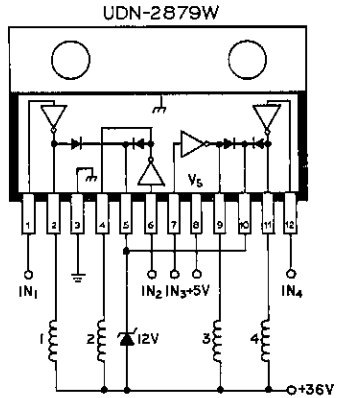

DWG. NO. A-11,976

DIGIT DRIVER
 FOR MULTIPLEXED INCANDESCENT LAMP DISPLAY

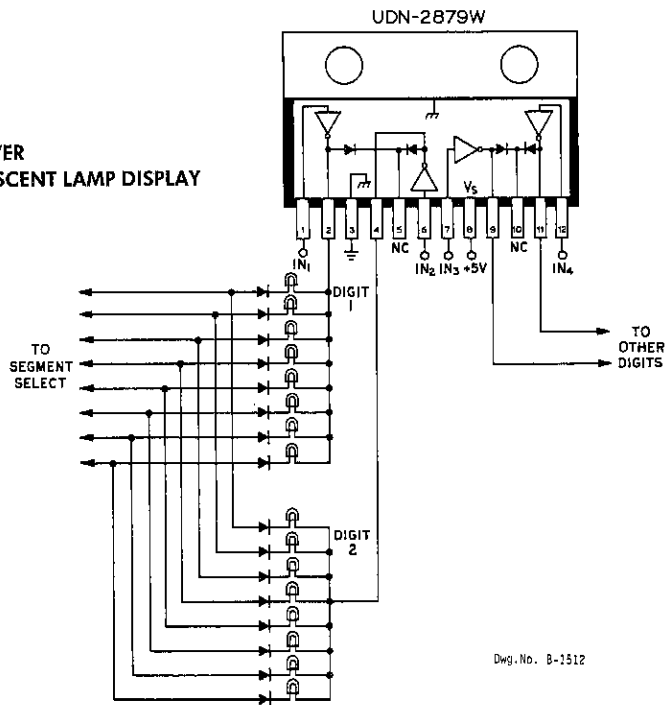

Dwg. No. B-2512

UDN-2931B AND UDN-2931W 3-PHASE BRUSHLESS DC MOTOR DRIVERS

FEATURES

- Output Current of 2 A
- Internal Transient-Suppression Diodes
- Low-Saturation Output Drivers
- Anti-Crossover Protection
- Braking and Chopping Functions (UDN-2931B)
- Thermal Shutdown with Hysteresis
- External Current-Sense Capability
- Input Lockout Circuitry

The UDN-2931B/W 3-phase brushless dc motor driver is designed for low output saturation-voltage levels. These drivers maximize motor capacity limited by power supply constraints. The output driver features low output saturation source and sink drivers and integral output suppression diodes. The outputs are capable of maintaining an output OFF voltage of 15 V and an ON current of 2 A (3.5 A peak).

Crossover current protection has been incorporated to guard against common sink and source drivers being ON at the same time. Circuitry on the input structure has been added to lock-out the sink driver when both driver inputs have been activated at the same time.

The UDN-2931B has extended flexibility with CHOP and BRAKE functions. The CHOP function affects the source driver by switching it ON and OFF while the CHOP is being toggled. In utilizing the BRAKE function the source drivers are turned ON while the sink drivers are turned OFF. The BRAKING input is active low. Crossover-current protection is still in operation during BRAKING.

Both devices feature a common-emitter pin on the sink drivers. The emitter-current sense is useful in chopper-mode configurations. Thermal shutdown in these devices has been set to 165°C.

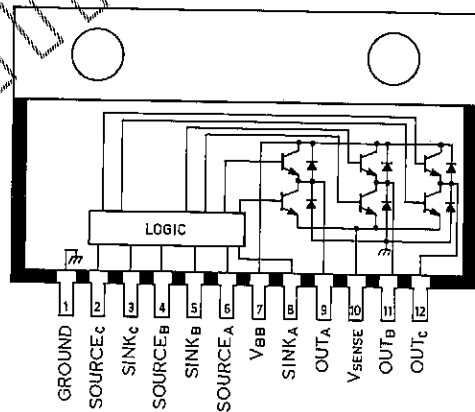
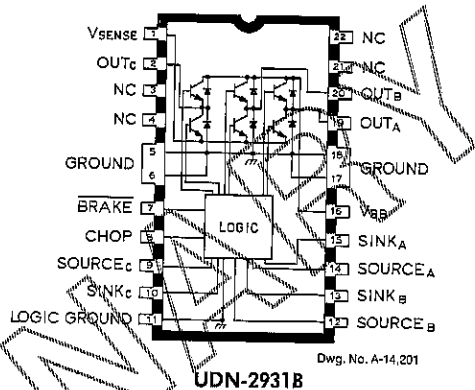

The UDN-2931B is supplied in a 16-pin dual in-line package with heat-sink contact tabs. This package allows for ease of circuit-board insertion. The UDN-2931W is supplied in a 12-pin single in-line power-tab package. These packages allow for easy attachment of an external heat-sink for extended power dissipation capabilities.

4

UDN-2931B AND UDN-2931W
3-PHASE BRUSHLESS DC MOTOR DRIVERS

ABSOLUTE MAXIMUM RATINGS
at $T_A = +25^\circ\text{C}$

Motor Supply Voltage, V_{BB}	15 V
Output Current, I_{OUT} (Peak)	± 3.5 A
(DC)	± 2.0 A
Input Voltage, V_{IN}	7.0 V
Sense Voltage, V_{SENSE}	1.5 V
Package Power Dissipation, P_D	
(UDN-2931B)	2.77 W*
(UDN-2931W)	5.2 W**
Operating Temperature Range, T_A	-20°C to $+85^\circ\text{C}$
Storage Temperature Range, T_S	-55°C to $+150^\circ\text{C}$

*Derate at the rate of 22.22 mW/ $^\circ\text{C}$ above $T_A = +25^\circ\text{C}$.
 **Derate at the rate of 41.16 mW/ $^\circ\text{C}$ above $T_A = +25^\circ\text{C}$.

FUNCTIONAL BLOCK DIAGRAM

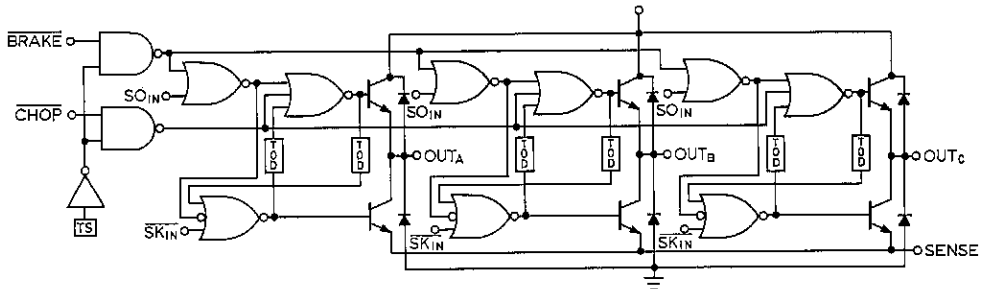

TOD = TURN ON DELAY, TS = THERMAL SHUTDOWN

Dwg. No. A-14,203

ELECTRICAL CHARACTERISTICS at $T_{TAB} = +70^{\circ}\text{C}$, $V_{BB} = 15\text{V}$

Characteristic	Symbol	Conditions	Limits			Units
			Min.	Typ.	Max.	
Output Leakage Current	I_{DEX}	All Drivers OFF, $V_{OUT} = 0\text{V}$	—	< -1.0	-100	μA
		All Drivers OFF, $V_{OUT} = 15\text{V}$	—	< 1.0	100	μA
Output Sustaining Voltage	$V_{CE(SUS)}$	$I_{OUT} = \pm 2\text{A}$, $L = 2\text{mH}$	15	—	—	V
Output Saturation Voltage	$V_{CE(SAT)}$	$I_{OUT} = 2\text{A}$	—	—	0.7	V
		$I_{OUT} = -2\text{A}$	—	0.5	1.3	V
Motor Supply Voltage Range	V_{BB}		7.0	1.0	15	V
Motor Supply Current	$I_{BB(OFF)}$	All channels OFF	—	10	12	mA
		One Source and Sink Driver ON, No Load	—	75	120	mA
Clamp Diode Forward Voltage	V_F	$I_F = 2.0\text{A}$	—	1.7	2.0	V
Clamp Diode Leakage Current	I_R	$V_R = 15\text{V}$	—	< 1.0	100	μA
Logic Input Current	$I_{IN(1)}$	$V_{IN} = 2.0\text{V}$	—	< 1.0	10	μA
		$V_{IN} = 0.8\text{V}$	—	-50	-200	μA
Logic Input Voltage	$V_{IN(1)}$	All inputs	2.0	—	—	V
		All inputs	—	—	0.8	V
Chopping Frequency	f_{CHOP}	$I_{OUT} = 2\text{A}$, $L = 2\text{mH}$, 90% Duty Cycle	—	—	400	KHz
Thermal Shutdown Temperature	T_{DR}	Note 1	—	165	—	$^{\circ}\text{C}$

1. Thermal shutdown typically has a hysteresis of 15°C .



TYPICAL APPLICATION

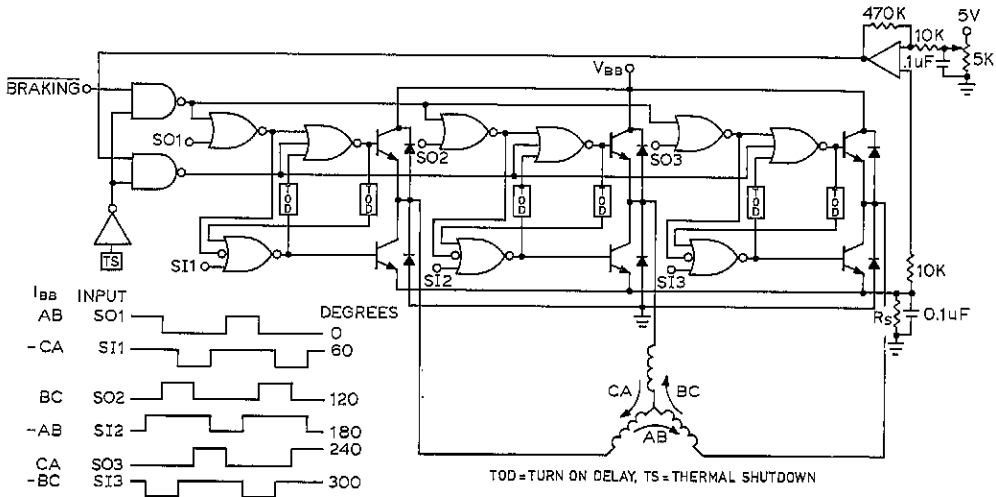

Dwg. No. A-14,204

UDN-2935Z AND UDN-2950Z BIPOLAR HALF-BRIDGE MOTOR DRIVERS

FEATURES

- 3.5 A Peak Output
- 37 V Min. Output Breakdown
- Output Transient Protection
- Tri-State Outputs
- TTL, CMOS, PMOS, NMOS Compatible Inputs
- Internal Thermal Shutdown
- High-Speed Chopper (to 100 kHz)
- UDN-2935Z Replaces SG3635P
- UDN-2950Z Replaces UDN-2949Z, SN75605
- TO-220 Style Packages

BOTH Type UDN-2935Z and UDN-2950Z integrated circuits are designed for servo-motor applications using pulse-width modulation. These two high-current, monolithic half-bridge motor drivers combine a sink-and-source driver with diode transient protection, input gain, level shifting, logic stages, and a voltage regulator for single-supply operation.

The UDN-2935Z output goes high with an active low input at pin 2; it is especially desirable in NMOS microprocessor applications. The UDN-2950Z output goes high with an active high input at pin 2; its inputs can be tied together for single-wire control. The input circuitry of both devices is compatible with TTL and low-voltage CMOS, PMOS, and NMOS logic. Both ICs have logic lockout (tri-state output) that prevents source and sink drivers from turning ON simultaneously.

In typical applications, the chopper-drive mode is characterized by low power-dissipation levels, low saturation voltages, and short chopper-storage

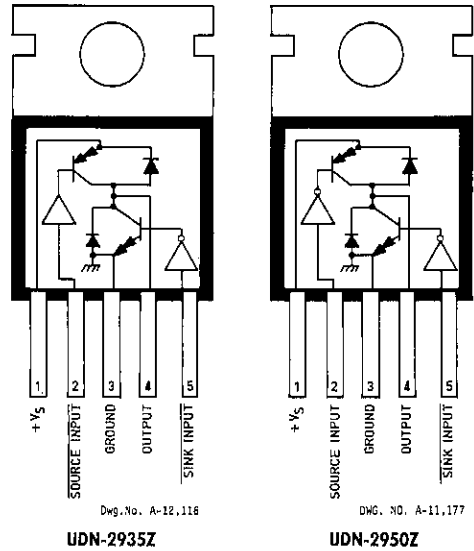

times for the sink drivers. The motor drivers can be used in pairs for full-bridge operation, or as triplets in three-phase brushless d-c motor-drive applications. They can also be teamed with the Sprague Electric UCN-4202A stepper motor translator/driver for bipolar d-c stepper motor control

The motor drivers' single-chip construction and power-tab TO-220 package enable cost-effective and reliable system designs supported by excellent power-dissipation ratings, minimum size, and ease of installation; because the package's heat tab is at ground potential, several devices can share a common heat sink without insulating hardware.

ABSOLUTE MAXIMUM RATINGS

Supply Voltage Range, V_S	8.0 V to 35 V
Output Voltage Range, V_{OUT}	-2.0 V to $V_S + 2.0$ V
Input Voltage Range, V_{IN}	-0.3 V to +7.0 V
Peak Output Current (100 ms, 10% d-c), I_{OP}	± 3.5 A
Continuous Output Current, I_{OUT}	± 2.0 A
Package Power Dissipation, P_D	See Graph
Operating Temperature Range, T_A	-20°C to +85°C
Storage Temperature Range, T_S	-55°C to +85°C

**ALLOWABLE POWER DISSIPATION
AS A FUNCTION OF AMBIENT TEMPERATURE**

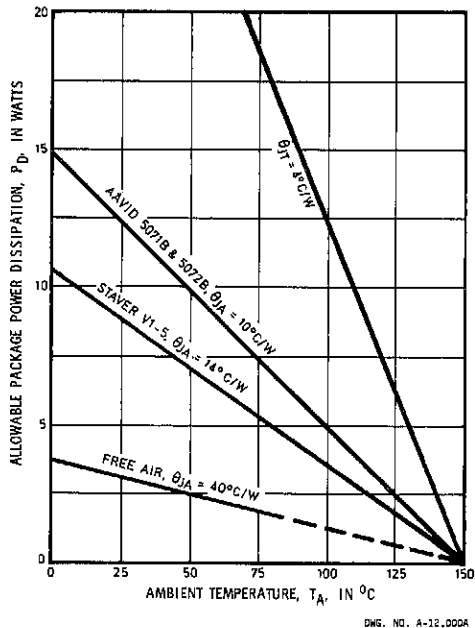

4

TRUTH TABLE

Source Driver, Pin 2	Sink Driver, Pin 5	Output, Pin 4	
		UDN-2935Z	UDN-2950Z
Low	Low	High	Low
Low	High	High	High Z
High	Low	Low	High
High	High	High Z	High

FUNCTIONAL BLOCK DIAGRAMS

UDN-2935Z

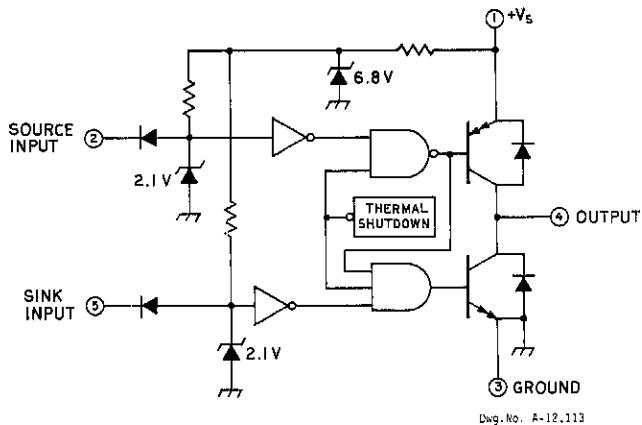

UDN-2950Z

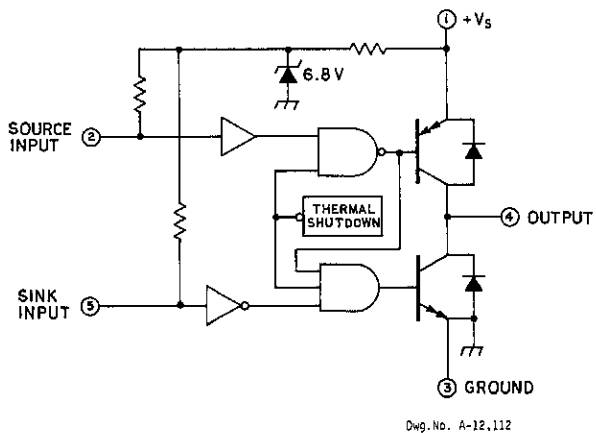

**UDN-2935Z AND UDN-2950Z
BIPOLAR HALF-BRIDGE MOTOR DRIVERS**

ELECTRICAL CHARACTERISTICS at $T_A = +25^\circ\text{C}$, $T_{TAB} = +70^\circ\text{C}$, $V_S = 35\text{ V}$ (unless otherwise noted)

Characteristic	Source Driver Input, Pin 2		Sink Driver Input, Pin 5	Output, Pin 4	Other	Limits		Units
	UDN-2935Z	UDN-2950Z				Min.	Max.	
Output Leakage Current	2.4 V	0.8 V	2.4 V	0 V	—	—	-500	μA
	2.4 V	0.8 V	2.4 V	35 V	—	—	500	μA
Output Sustaining Voltage	2.4 V	0.8 V	0.8 to 2.4 V	2.0 A	Fig. 1	35	—	V
Output Saturation Voltage	0.8 V	2.4 V	2.4 V	-2.0 A	—	33	—	V
	2.4 V	0.8 V	0.8 V	2.0 A	—	—	2.0	V
Output Source Current	0.8 V	2.4 V	2.4 V	—	—	-2.0	—	A
Output Sink Current	2.4 V	0.8 V	0.8 V	—	—	2.0	—	A
Input Open-Circuit Voltage	-250 μA	-250 μA	-250 μA	—	—	—	7.5	V
Input Current	—	2.4 V	2.4 V	NC	—	—	-700	μA
	2.4 V	—	2.4 V	NC	—	—	10	μA
	0.8 V	0.8 V	0.8 V	NC	—	—	-1.6	mA
Propagation Delay	2.4 V	0.8 V	0.8 to 2.4 V	2.0 A	—	—	750	ns
	0.8 to 2.4 V	2.4 to 0.8 V	2.4 V	2.0 A	—	—	2.0	μs
Clamp Diode Forward Voltage	NC	NC	NC	2.0 A	Fig. 2	—	2.2	V
Supply Current	0.8 V	2.4 V	NC	NC	—	—	35	mA

NOTE: Positive (negative) current is defined as going into (coming out of) the specified device pin.

TEST FIGURE 1

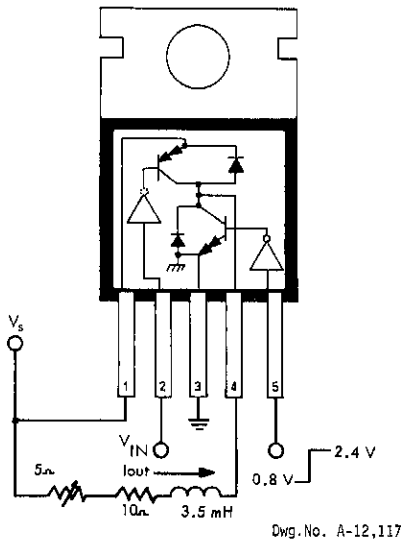

TEST FIGURE 2

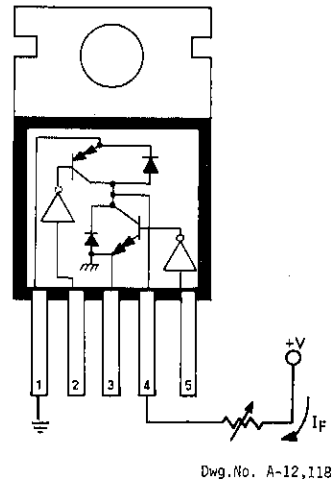

4

APPLICATION NOTES

It should be noted that an additional power dissipation component may arise from crossover currents flowing from supply to ground when current direction through the load is reversed. This is due to differences in the switching speeds between the source and sink drivers. Although the internal logic lockout protects these devices from catastrophic failure, the crossover power component can cause device operation at substantially higher junction temperatures.

If timing conditions are ignored, the magnitude of this power can be approximated as:

$$P_D = V_s \times I_C \times t \times f$$

where V_s = supply voltage

I_C = crossover current (≈ 3.5 A max.)

t = crossover current duration (≈ 1 μ s)

f = frequency of direction change

In some applications (high switching speeds or high package power dissipation), it is recommended that the inputs be driven separately, and that the sink driver not be turned ON for at least 2 μ s (maximum source t_{PD}) after the source driver input is turned OFF. The sink driver should be turned OFF at least 750 ns (maximum sink t_{PD}) before the source driver is turned ON.

RECOMMENDED TIMING CONDITIONS (UDN-2950Z shown)

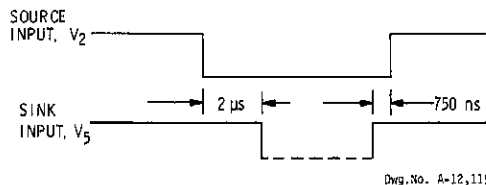
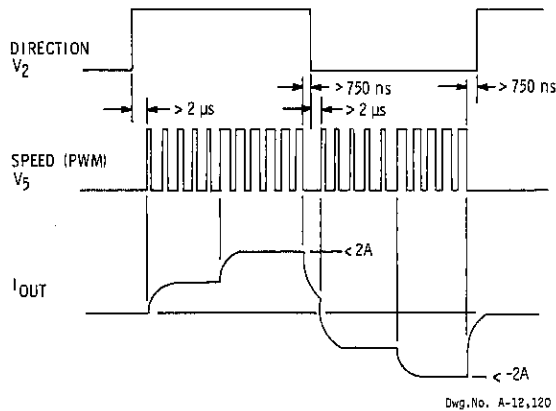

TYPICAL APPLICATIONS

3-PHASE BRUSHLESS DC MOTOR DRIVE

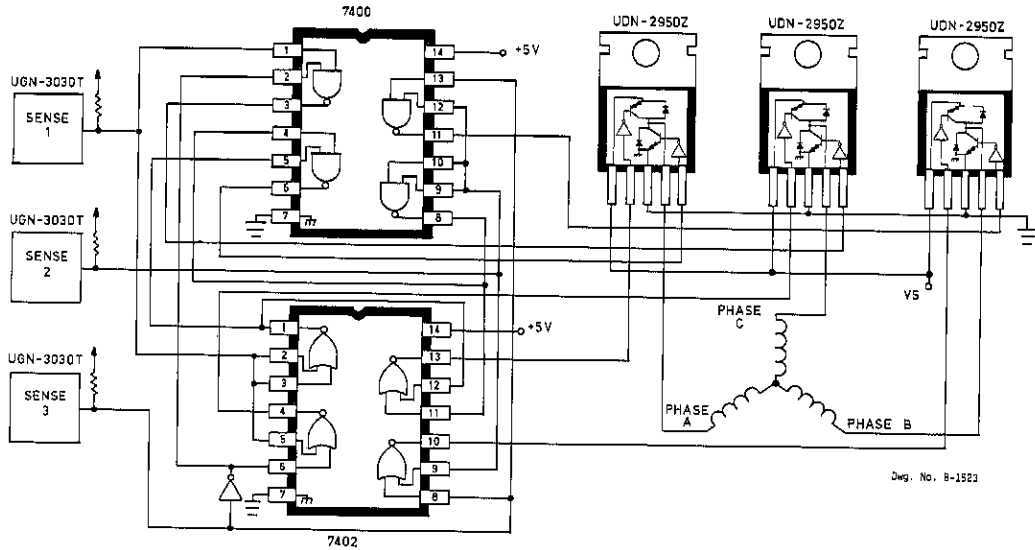

4

SINGLE-WINDING DC OR STEPPER MOTOR DRIVE

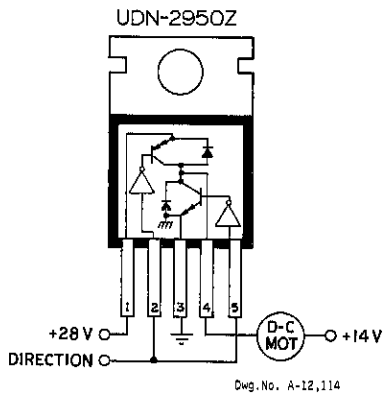

FULL-BRIDGE DC SERVO MOTOR DRIVE

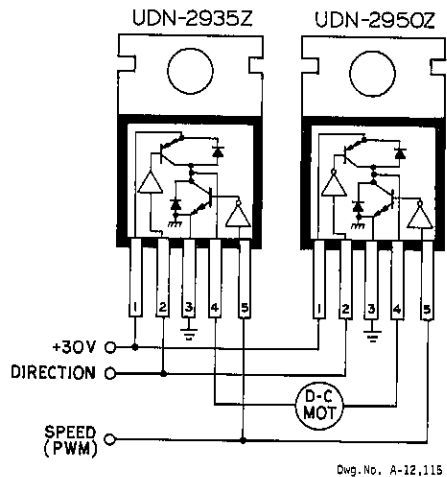

UDN-2936W AND UDN-2937W 3-PHASE BRUSHLESS DC MOTOR CONTROLLERS

FEATURES

- 10V to 45V Operation
- ± 4 A Peak Output Current
- Internal Clamp Diodes
- Internal PWM Current Control
- 60° Commutation Decoding Logic
- Thermal Shutdown Protection
- Compatible with Single-Ended or Differential Hall Effect Sensors
- Braking and Direction Control (UDN-2936W Only)

Combining logic and power, the UDN-2936W and the UDN-2937W provide commutation and drive for a three-phase brushless dc motor. Each of the three push-pull outputs are rated at 45 V and ± 3 A (± 4 A peak), and have internal ground clamp and flyback power diodes. These drivers also feature internal commutation logic, PWM current control, and thermal shutdown protection.

The UDN-2936W is compatible with single-ended digital or linear Hall effect sensors. The commutating logic is programmed for 60° electrical separation (other separation sequences, such as 120°, are available via mask programming at the factory). Current control is accomplished by sensing current through an external sense resistor and pulse-width modulating the source drivers. Voltage thresholds and hysteresis can be externally set by the user. If desired, internal threshold and hysteresis defaults (300 mV, 7.5 percent) can be used. The UDN-2936W also features braking and direction control. Internal protection circuitry prevents crossover current when braking or changing direction.

The UDN-2937W is compatible with linear differential buffered and unbuffered Hall effect sensors. By changing sensor output polarities, various commutation sequences, such as 60°, 120°, or 240°, can be set. The PWM current control threshold and hysteresis is set at 300 mV and 7.5 percent. The peak output current is determined by a user-selected external sense resistor.

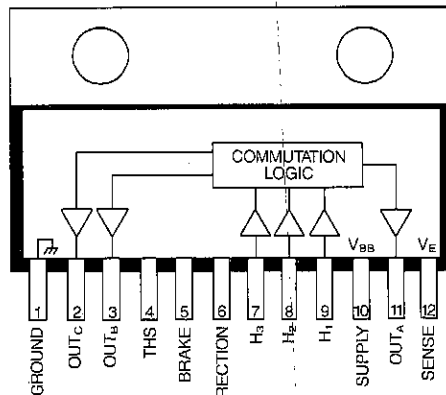

UDN-2936W

Dwg. No. W-188

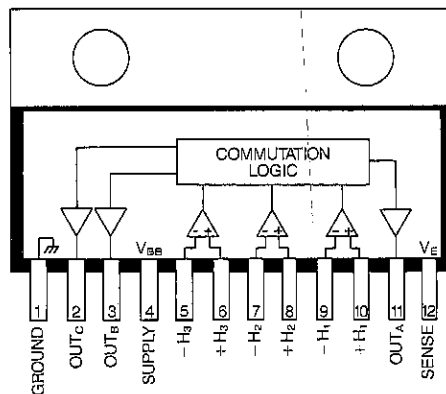

UDN-2937W

Dwg. No. W-189

For maximum power-handling capability, the UDN-2936W and UDN-2937W are supplied in 12-pin single in-line power tab packages. An external heat sink may be required for high-current applications. The tab is at ground potential and needs no insulation.

ABSOLUTE MAXIMUM RATINGS
at $T_{TAB} \leq +70^{\circ}C$

Supply Voltage, V_{BB}	45V
Output Current, I_{OUT} (continuous)	$\pm 3A$
(peak)	$\pm 4A$
Input Voltage Range, V_{IN}	-0.3V to 15V
Threshold Voltage, V_{THS}	15V
Package Power Dissipation, P_D	See Graph
Operating Temperature Range, T_A	-20°C to +85°C
Storage Temperature Range, T_S	-55°C to +150°C

NOTE: Output current rating may be limited by duty cycle, ambient temperature, and heat sinking. Under any set of conditions, do not exceed the specified peak current and a junction temperature of +150°C.

FUNCTIONAL BLOCK DIAGRAM
UDN-2936W

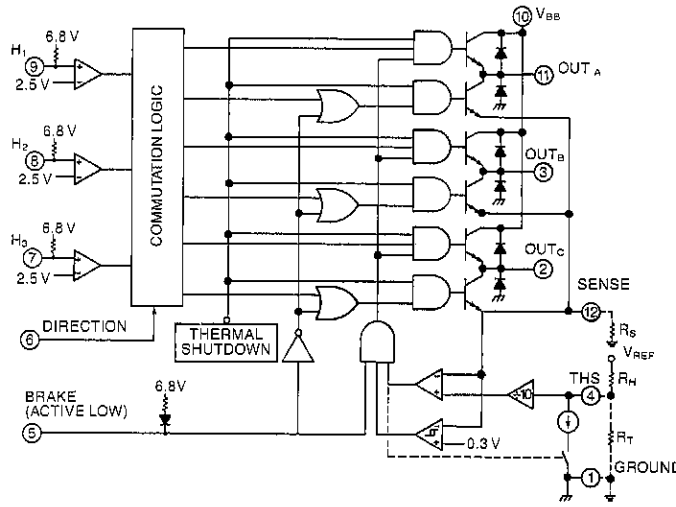

Dwg. No. W-190

COMMUTATION TRUTH TABLE
UDN-2936W

Hall Sensor Inputs			Outputs				
H ₁	H ₂	H ₃	Direction	Brake	OUT _A	OUT _B	OUT _C
High	High	High	Low	High	Z	Low	High
High	High	Low	Low	High	High	Low	Z
High	Low	Low	Low	High	High	Z	Low
Low	Low	Low	Low	High	Z	High	Low
Low	Low	High	Low	High	Low	High	Z
Low	High	High	Low	High	Low	Z	High
High	High	High	High	High	Z	High	Low
High	High	Low	High	High	Low	High	Z
High	Low	Low	High	High	Low	Z	High
Low	Low	Low	High	High	Z	Low	High
Low	Low	High	High	High	High	Low	Z
Low	High	High	High	High	High	Z	Low
X	X	X	X	Low	Low	Low	Low

X = Irrelevant
Z = High Impedance

**UDN-2936W AND UDN-2937W
3-PHASE BRUSHLESS DC MOTOR DRIVERS**

**FUNCTIONAL BLOCK DIAGRAM
UDN-2937W**

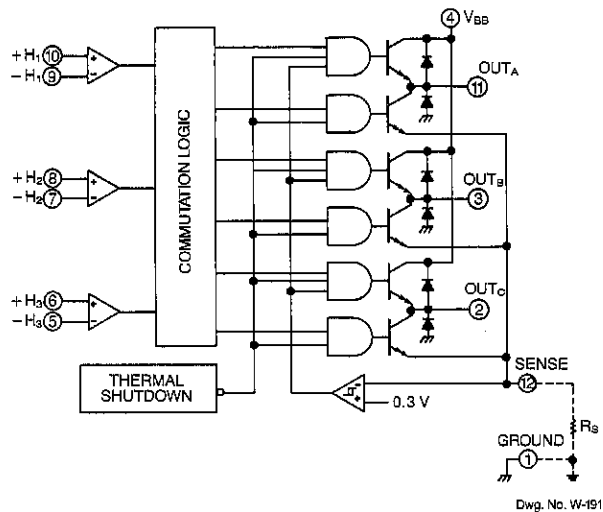

**COMMUTATION TRUTH TABLE
UDN-2937W**

Hall Sensor Inputs*			Outputs		
+ H ₁	+ H ₂	+ H ₃	OUT _A	OUT _B	OUT _C
High	High	High	Z	Low	High
High	High	Low	High	Low	Z
High	Low	Low	High	Z	Low
Low	Low	Low	Z	High	Low
Low	Low	High	Low	High	Z
Low	High	High	Low	Z	High

* Inputs are with respect to - H_N inputs.

Z = High Impedance

TYPICAL HALL EFFECT SENSOR LOCATIONS

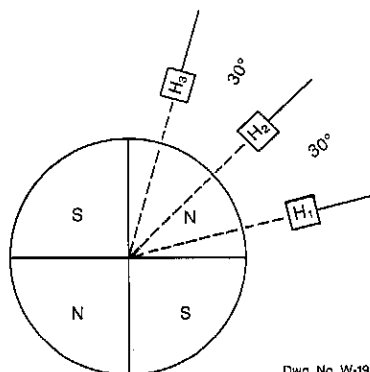

Dwg. No. W-193

ELECTRICAL CHARACTERISTICS at $T_A = +25^\circ\text{C}$, $T_{TAB} \leq 70^\circ\text{C}$, $V_{BB} = 45\text{V}$

Characteristic	Symbol	Test Conditions	Limits			Units
			Min.	Typ.	Max.	
Supply Voltage Range	V_{BB}	Operating	10	—	45	V
Supply Current	I_{BB}	Outputs Open	—	52	60	mA
		$V_{BRAKE} = 0.8\text{V}$, UDN-2936W Only	—	54	60	mA
Thermal Shutdown Temperature	T_J		—	165	—	$^\circ\text{C}$
Thermal Shutdown Hysteresis	ΔT_J		—	25	—	$^\circ\text{C}$

Output Drivers

Output Leakage Current	I_{CEX}	$V_{OUT} = V_{BB}$	—	—	50	μA
		$V_{OUT} = 0\text{V}$	—	—	—50	μA
Output Saturation Voltage	$V_{CE(SAT)}$	$I_{OUT} = -1\text{A}$	—	1.7	1.9	V
		$I_{OUT} = +1\text{A}$	—	1.1	1.3	V
		$I_{OUT} = -2\text{A}$	—	1.9	2.1	V
		$I_{OUT} = +2\text{A}$	—	1.4	1.6	V
		$I_{OUT} = -3\text{A}$	—	2.35	2.50	V
		$I_{OUT} = +3\text{A}$	—	1.85	2.00	V
Output Sustaining Voltage	$V_{CE(SUS)}$	$I_{OUT} = \pm 3\text{A}$, $L = 2\text{mH}$	45	—	—	V
Clamp Diode Forward Voltage	V_F	$I_F = 2\text{A}$	—	1.8	2.0	V
Clamp Diode Leakage Current	I_R	$V_R = 45\text{V}$	—	—	50	μA
Output Switching Time	t_r	$I_{OUT} = \pm 2\text{A}$, Resistive Load	—	2.0	—	μs
		$I_{OUT} = \pm 2\text{A}$, Resistive Load	—	2.0	—	μs
Turn-ON Delay (Resistive Load)	t_{on}	Source Drivers, 0 to -2A	—	1.25	—	μs
		Sink Drivers, 0 to $+2\text{A}$	—	1.9	—	μs
Turn-OFF Delay (Resistive Load)	t_{off}	Source Drivers, -2A to 0	—	1.7	—	μs
		Sink Drivers, $+2\text{A}$ to 0	—	0.9	—	μs

UDN-2936W Control Logic

Logic Input Voltage	$V_{IN(1)}$	V_{DIR} or V_{BRAKE}	2.0	—	—	V
	$V_{IN(0)}$	V_{DIR} or V_{BRAKE}	—	—	0.8	V
Sensor Input Voltage Threshold	V_{IN}	H_1 , H_2 , or H_3	—	2.5	—	V
Input Current	$I_{IN(1)}$	$V_{DIR} = 2\text{V}$	—	150	200	μA
		$V_{BRAKE} = 2\text{V}$	—	<1.0	5.0	μA
		$V_H = 5\text{V}$	—	-190	-220	μA
	$I_{IN(0)}$	$V_{DIR} = 0.8\text{V}$	—	35	50	μA
		$V_{BRAKE} = 0.8\text{V}$	—	-5.0	-20	μA
		$V_H = 0.8\text{V}$	—	-0.64	-1.0	mA
	I_{THS}	$V_{THS} \geq 3.0\text{V}$	—	-8.0	-15	μA
$V_{THS} < 3.0\text{V}$, $V_{SENSE} < V_{THS}/10.5$		—	-15	-30	μA	
$V_{THS} < 3.0\text{V}$, $V_{SENSE} > V_{THS}/9.5$		140	200	260	μA	
Current Limit Threshold		V_{THS} / V_{SENSE} at trip point, $V_{THS} < 3.0\text{V}$	9.5	10	10.5	
Default Sense Trip Voltage	V_{SENSE}	$V_{THS} \geq 3.0\text{V}$	270	300	330	mV
Default Hysteresis		$V_{THS} \geq 3.0\text{V}$	—	7.5	—	%
Deadtime	t_d	BRAKE or DIRECTION	—	2.0	—	μs

UDN-2937W Control Logic

Input Common-Mode Voltage Range	V_{CM}		1.5	2.0	4.0	V
Input Voltage Hysteresis	$V_{IN(HYS)}$		—	10	—	mV
Input Current	I_{IN}	$V_{IN} = 5\text{V}$	—	12	20	μA
Sense Trip Voltage	V_{SENSE}		270	300	330	mV
Hysteresis			—	7.5	—	%

4

APPLICATIONS INFORMATION

The UDN-2936 and UDN-2937W power drivers provide commutation logic and power outputs to drive a three-phase brushless DC motor.

UDN-2936W

The UDN-2936W is designed to interface with single-ended linear or digital Hall effect devices (HEDs). Internal pull-up resistors on the UDN-2936W inputs allow for direct use with open-collector digital HEDs. The H_N inputs have 2.5 V thresholds.

The commutation logic provides decoding for HEDs with 60° electrical separation (other separations available via mask programming). At any one step in the sequencing, one half-bridge driver is sourcing, one driver is sinking, and one driver is in a high-impedance state (see truth table). Changing the logic level of the DIRECTION pin inverts the output states, thus reversing the direction of the motor. A logic low on the BRAKE pin turns ON all three sink drivers and turns OFF all source drivers, dynamically braking the motor. An internally-generated dead time (t_d) of about 2 μ s prevents potentially destructive crossover currents that can occur when changing direction or braking. In some high supply voltage applications, it may be necessary to brake the motor before changing direction.

Motor current is internally controlled by pulse-width modulating the source drivers with a preset hysteresis format. Load current through an external sense resistor (R_S) is constantly monitored. When the current reaches the set trip point (determined by an external reference voltage or internal default), the source driver is disabled. Current recirculates through the ground clamp diode, motor winding, and sink driver. An internal constant-current sink reduces the trip point (hysteresis). When the decaying current reaches this lower threshold, the source driver is enabled again and the cycle repeats.

Thresholds and hysteresis can be set with external resistors or internal defaults can be used. With $V_{THS} >$

3.0 V, the trip point is internally set at 300 mV with 7.5 percent hysteresis. Load current is then determined by the equation:

$$I_{MAX} = 0.3/R_S$$

With $V_{THS} < 3.0$ V, the threshold, hysteresis percentage, and peak current are set with external resistors according to the equations:

$$\text{Threshold Voltage } (V_{THS}) = V_{REF} \cdot R_T / (R_H + R_T)$$

$$\text{Hysteresis Percentage} = R_H / 50 V_{REF}$$

$$\text{Load Trip Current } (I_{MAX}) = V_{THS} / (10 R_S)$$

Percentage hysteresis is a fixed value independent of load current. The chopping frequency is a function of circuit parameters including load inductance, load resistance, supply voltage, hysteresis, and switching speed of the drivers.

UDN-2937W

The inputs of the UDN-2937W are designed to interface directly with the outputs of differential buffered or unbuffered HEDs. Various commutation sequences (60°, 120°, 240°) can be set by using appropriate HED output polarities shown in the truth table.

The UDN-2937W load current control circuitry works the same as in the UDN-2936W except that only the internal threshold and hysteresis settings can be used. With the threshold of 300 mV and hysteresis of 7.5 percent, load current is determined by:

$$I_{MAX} = 0.3/R_S$$

Both the UDN-2936W and UDN-2937W outputs are rated for normal operating currents of up to 3 A and start-up currents to 4 A. Internal power ground clamp and fly-back diodes protect the outputs from the voltage transients that occur when switching inductive loads. Both devices also feature thermal protection circuitry. If the junction temperature reaches 165°C, the thermal shutdown circuitry turns OFF all output drivers. The outputs are re-enabled when the junction cools down to approximately 140°C.

TYPICAL APPLICATION

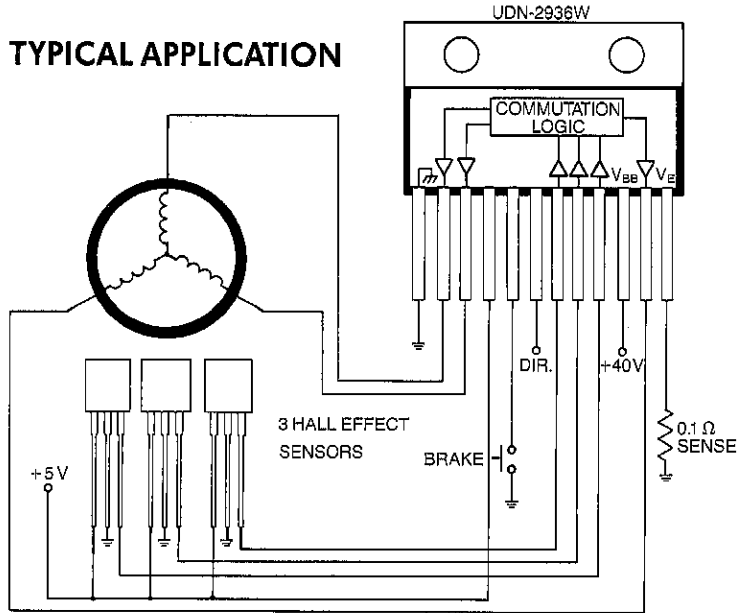

Dwg. No. W-192

4

ALLOWABLE AVERAGE PACKAGE POWER DISSIPATION
AS A FUNCTION OF TEMPERATURE

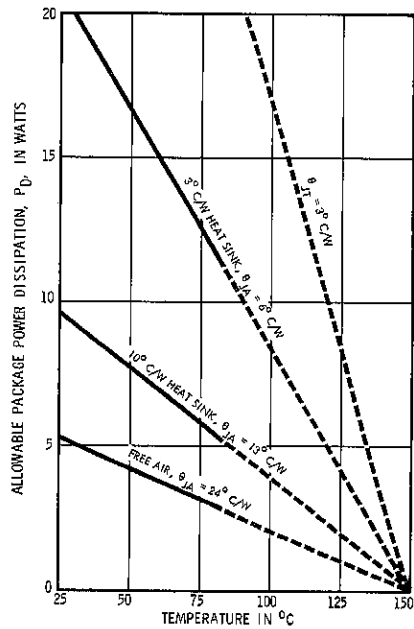

Dwg. No. A-11,794A

UDN-2938W AND UDN-2939B 3-PHASE UNIPOLAR BRUSHLESS DC MOTOR DRIVERS

FEATURES

- Output Voltage of 30 V
- Output Current of 4 A
- Integral Transient-Suppression Diodes
- External Output Driver Capacitor Pins
- Thermal Shutdown Circuitry
- TTL, DTL, CMOS Compatible Inputs

The UDN-2938W and UDN-2939B are three-phase unipolar brushless dc motor drivers capable of handling 4 A drive currents, an output OFF voltage of 50 V, and a sustaining voltage of 30 V. The output drive structure of these devices have been designed for low saturation voltages (less than 1.0 V at 1 A). UDN-2938W and UDN-2939B are functionally identical except that the UDN-2939B has ENABLE input for extended control flexibility. The bases of the output drivers have been brought out to external pins so that capacitors may be connected in order to stimulate an ac drive and to avoid EMI and RFI problems.

Output transient-suppression diodes have been incorporated for use with inductive loads. Inputs are active high and float low. These inputs are TTL, DTL, and 5 V-12 V CMOS compatible. The ENABLE function (UDN-2939B) is active high and, when

FUNCTIONAL BLOCK DIAGRAM

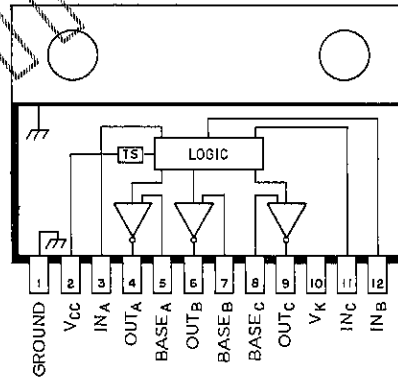
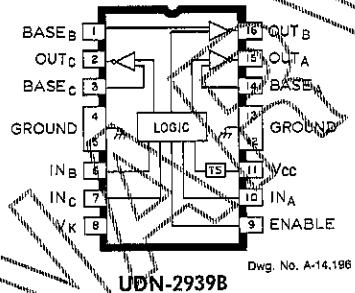
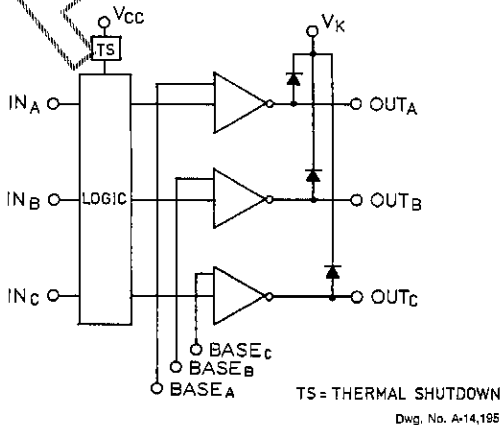

UDN-2938W

pulled low, will turn OFF all output drivers. These devices have thermal shutdown circuitry with hysteresis to guard against overheating. This thermal shutdown circuitry is designed to operate at a temperature of 165°C. A logic supply current regulator has been introduced into these devices to maintain a relatively constant output base drive over the logic supply (V_{CC}) operating range.

The UDN-2938W is packaged in a single in-line 12-pin power-tab SIP package with lead centers at 0.100 inches. The UDN-2939B is packaged in a 16-pin dual in-line batwing package with heat-sink contact tabs.

ABSOLUTE MAXIMUM RATINGS
at +25°C

Output Voltage, V_{CE}	50 V
Output Sustaining Voltage, $V_{CE(SUS)}$	30 V
Output Current, I_{OUT}	5 A
Logic Supply, V_{CC}	15 V
Input Voltage, V_{IN}	15 V
Package Power Dissipation, P_D	
(W Package)	5.2 W*
(B Package)	2.77 W**
Operating Temperature Range, T_A	-20°C to +85°C
Storage Temperature Range, T_S	-55°C to +150°C

*Derate at the rate of 41.16 mW/°C above $T_A = +25°C$.
**Derate at the rate of 22.22 mW/°C above $T_A = +25°C$.

TYPICAL APPLICATION

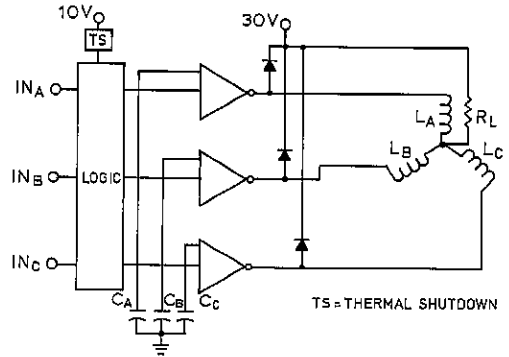

4

ELECTRICAL CHARACTERISTICS at $T_A = +25°C$, $V_{CC} = 5.0 V$ (Unless otherwise noted)

Characteristic	Symbol	Test Conditions	Limits			Units
			Min.	Typ.	Max.	
Logic Supply Voltage Range	V_{CC}		4.5	—	15	V
Output Leakage Current	I_{CEX}	$V_{OUT} = 50 V$	—	<1.0	100	μA
Output Sustaining Voltage	$V_{CE(SUS)}$	$I_{OUT} = 4.0 A$	30	—	—	V
Output Saturation Voltage	$V_{CE(SAT)}$	$I_{OUT} = 1.0 A$	—	0.9	1.1	V
		$I_{OUT} = 4.0 A$	—	1.9	2.0	V
Clamp Diode Leakage Current	I_R	$V_R = 50 V$	—	<1.0	100	μA
Clamp Diode Forward Voltage	V_F	$I_F = 1.0 A$	—	1.3	1.5	V
Input Voltage	$V_{IN(L)}$		—	—	2.0	V
	$V_{IN(O)}$		0.8	—	—	V
Input Current	$I_{IN(L)}$	$V_{IN} = 2.4 V$	—	30	50	μA
	$V_{IN(O)}$	$V_{IN} = 0.8 V$	—	—	1.0	μA
Supply Current	$I_{CC(ON)}$	One Driver ON, No Load	—	12	15	mA
	$I_{CC(OFF)}$	All Drivers OFF	—	5.0	8.0	mA
Thermal Shutdown Temperature	T_J		—	165	—	°C

UDN-2941B
QUAD HIGH-CURRENT SOURCE DRIVER

FEATURES

- 1.5 A Output Source Current
- Minimized Saturation Voltage
- 30 V Output Sustaining Voltage
- Transient-Protected Outputs
- TTL or CMOS Compatible Inputs
- Plastic Dual In-Line Package With Heat-Sink Contact Tabs

HIGH-CURRENT SOURCE DRIVERS are designed to serve as interface between low-level logic and a variety of peripheral power loads, including solenoids, d-c or stepper motors using pulse-width modulation, and multiplexed LED or incandescent displays.

The UDN-2941B high-current source driver has four independent emitter-follower drivers. Special circuit design techniques, resulting in reduced output-saturation voltages, allow any one driver to source up to -1.5 A continuously with minimal voltage drops and package power dissipation.

The device's high switching speed prevents "ghosting" effects when it is used to drive multiplexed displays. All outputs are rated for operation to 35 V (30 V sustaining). The low-level inputs are compatible with most TTL, DTL, LSTTL, and low-voltage CMOS or PMOS logic.

The UDN-2941B integrated circuit is supplied in a 16-pin plastic dual in-line package with copper heat-sink contact tabs. The lead configuration facilitates attachment of an inexpensive external heat sink for

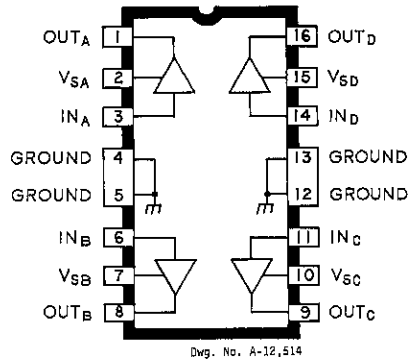

maximum power dissipation with standard cooling methods. It fits a standard IC socket or printed wiring board layout. The heat sink is at ground potential and needs no insulation.

Similar devices, for operation with load currents of up to -500 mA, are the 8-channel source drivers of Series UDN-2980A.

ABSOLUTE MAXIMUM RATINGS

Supply Voltage Range, V_S	12 V to 35 V
Peak Output Current, I_{OUT}	-2.0 A
Input Voltage, V_{IN}	15 V
Package Power Dissipation, P_D	See Graph
Operating Temperature Range, T_A	-20°C to $+85^\circ\text{C}$
Storage Temperature, T_S	-55°C to $+150^\circ\text{C}$

Output current rating will be limited by ambient temperature, duty cycle, heat sinking, air flow, and number of outputs conducting. Under any set of conditions, do not exceed the -2.0 A peak current and a junction temperature of $+150^\circ\text{C}$.

PARTIAL SCHEMATIC
 One of 4 Drivers

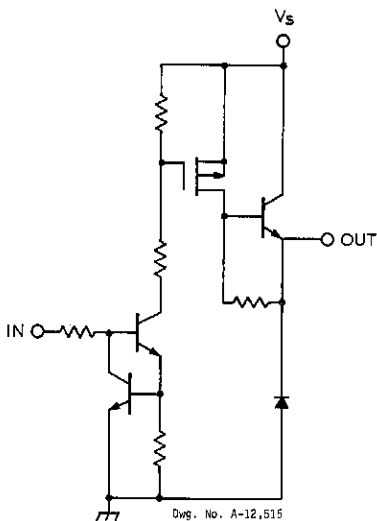

ALLOWABLE AVERAGE PACKAGE POWER DISSIPATION
 AS A FUNCTION OF TEMPERATURE

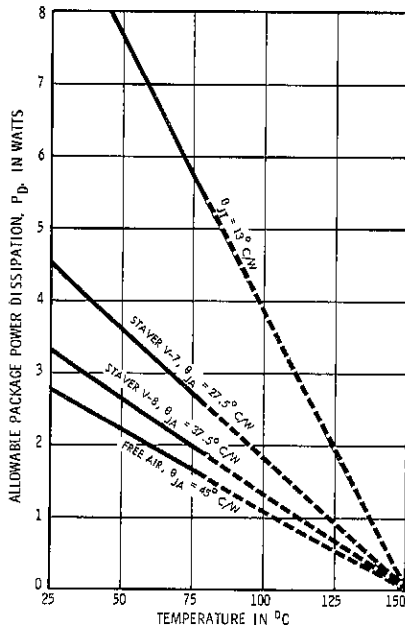

Dwg. No. A-11,793A

4

ELECTRICAL CHARACTERISTICS at $T_A = +25^\circ\text{C}$, $V_S = 35\text{ V}$, $T_{TAB} \leq +70^\circ\text{C}$

Characteristic	Symbol	Test Conditions	Limits			
			Min.	Typ.	Max.	Units
Output Leakage Current	I_{CEX}	$V_{IN} = 0.4\text{ V}$, $V_{OUT} = 0\text{ V}$, $T_A = +25^\circ\text{C}$	—	< -10	-100	μA
		$V_{IN} = 0.4\text{ V}$, $V_{OUT} = 0\text{ V}$, $T_A = +70^\circ\text{C}$	—	< -10	-500	μA
Output Sustaining Voltage	$V_{CE(SUS)}$	$V_{IN} = 2.4\text{ V}$, $I_{OUT} = -100\text{ mA}$	30	—	—	V
Output Saturation Voltage	$V_{CE(SAT)}$	$V_{IN} = 2.4\text{ V}$, $I_{OUT} = -1.0\text{ A}$	—	1.3	1.5	V
		$V_{IN} = 2.4\text{ V}$, $I_{OUT} = -1.5\text{ A}$	—	1.6	1.8	V
Input Current	$I_{IN(ON)}$	$V_{IN} = 2.4\text{ V}$	—	175	500	μA
		$V_{IN} = 0.4\text{ V}$	—	—	-10	μA
Output Source Current	I_{OUT}	$V_{IN} = 2.4\text{ V}$	-1.5	—	—	A
Total Supply Current	I_S	$V_{IN} = 2.4\text{ V}$ (Note 3), Outputs Open	—	11	15	mA
Clamp Diode Leakage Current	I_R	$V_R = 35\text{ V}$	—	<10	100	μA
Clamp Diode Forward Current	V_F	$I_F = 1.5\text{ A}$	—	1.4	2.0	V
Turn-On Delay	t_{PLH}	$0.5 V_{in}$ to $0.5 V_{out}$, Resistive Load	—	0.25	2.5	μs
Turn-Off Delay	t_{PHL}	$0.5 V_{in}$ to $0.5 V_{out}$, Resistive Load	—	0.5	5.0	μs

- NOTES: 1. Each driver tested separately.
 2. Negative current is defined as coming out of (sourcing) the specified device pin.
 3. All inputs simultaneously.

TYPICAL APPLICATIONS

MULTIPLEXED COMMON-ANODE LED DISPLAY DRIVER

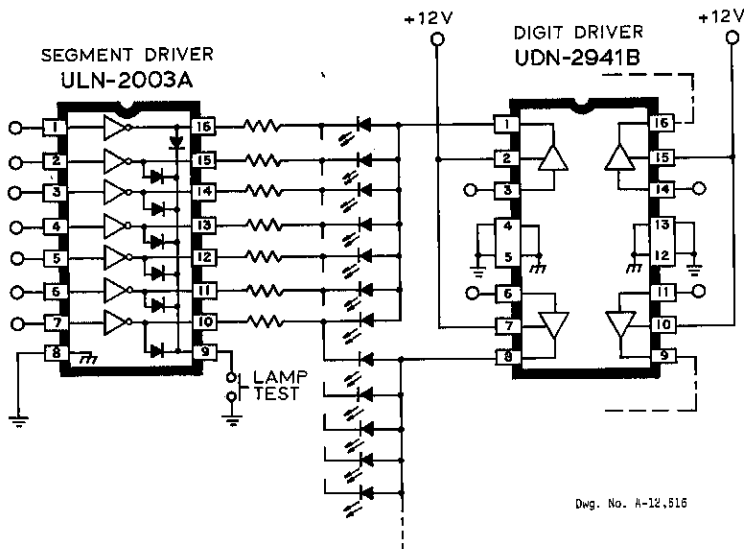

FULL-BRIDGE MOTOR DRIVER
 (One of 2 Windings)

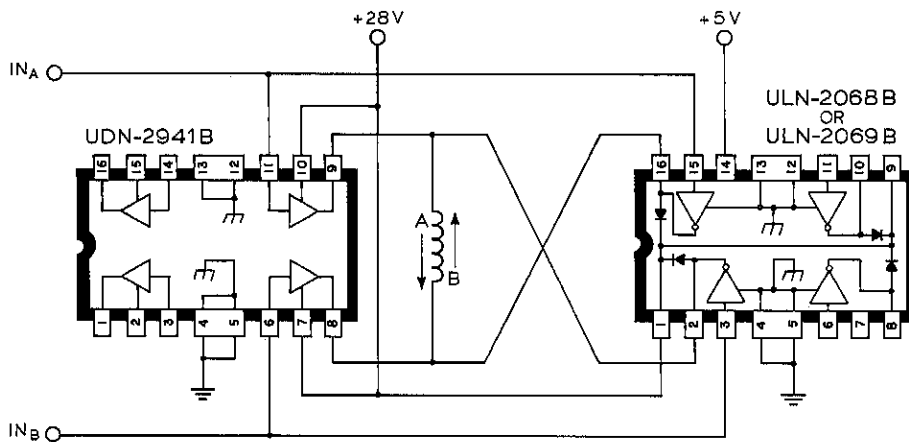

UDN-2943Z HIGH-CURRENT BIPOLAR HALF-BRIDGE MOTOR DRIVER

FEATURES

- ± 1 A Output Current
- 8.5 V to 24 V Operating Range
- Withstand 45 V Supply Transients
- Crossover-Current Protected
- Logic-Compatible Inputs
- Saturated Output Drivers
- Output Transient Protection
- Tri-State Output
- Internal Thermal Shutdown
- Internal Over-Voltage Protection
- Internal Short-Circuit Protection
- High-Speed Chopper (to 50 kHz)
- TO-220 Style Package

DESIGNED for use as a general-purpose motor driver, the UDN-2943Z half-bridge driver combines high-current sink and source drivers with logic stages, level shifting, diode transient protection, and a voltage regulator for single-supply operation. Capable of operating in extremely harsh environments, this device can withstand high ambient temperatures, output overloads, and repeated power supply transient voltages without damage. The driver can be used in pairs for full-bridge operation, or as triplets in three-phase brushless dc motor-driver applications.

The input circuitry is compatible with TTL, low-voltage CMOS, and NMOS logic. Logic lockout prevents both source and sink drivers from turning ON simultaneously. Each driver is turned ON by an active-low input, making the UDN-2943Z especially desirable in many microprocessor applications. An accidental input open circuit will turn OFF the corresponding output. The device also provides an internally-generated dead-time to prevent crossover currents during output switching. Monolithic, space-saving construction offers reliability unobtainable with discrete components.

Saturated output drivers provide for low saturation voltage at the maximum rated current. Internal

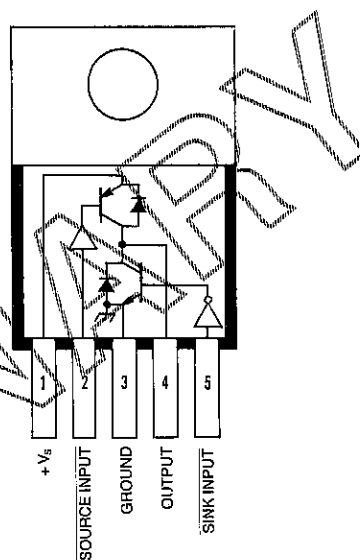

Dwg. No. A-14,135

4

short-circuit protection, activated at load currents above 1 A, protects the source driver from accidental short-circuits between the output and ground.

The UDN-2943Z driver is rated for continuous operation with inductive loads at supply voltages of up to 24 V. With the application of increased supply voltages (to 45 V maximum), a high-voltage protective circuit becomes operative, shutting OFF both output drivers. The internal thermal shutdown is triggered by a nominal junction temperature of 160°C.

Single-chip construction and a modified 5-lead JEDEC power-tab Style TO-220 plastic package provide cost-effective and reliable systems designs. It also features excellent power dissipation ratings, minimum size, and ease of installation. The heat-sink tab is at ground potential and does not require insulation.

UDN-2943Z
HIGH-CURRENT HALF-BRIDGE MOTOR DRIVER

**ALLOWABLE POWER DISSIPATION
AS A FUNCTION OF AMBIENT TEMPERATURE**

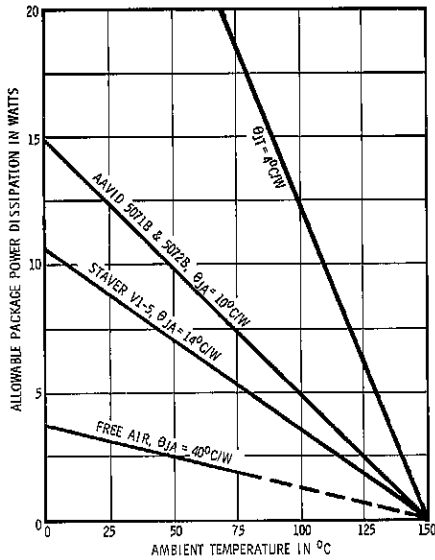

Dwg. No. A-12,000B

ABSOLUTE MAXIMUM RATINGS

Supply Voltage Range, V_S 8.5 V to 45 V*
Output Voltage, $V_{O(ENUS)}$ 24 V
Input Voltage Range, V_{IN} -0.3 V to +18 V
Continuous Output Current, I_{OUT} ± 1.0 A
Package Power Dissipation, P_D See Graph
Operating Temperature Range, T_A -20°C to +85°C
Storage Temperature Range, T_S -55°C to +150°C
*internal high-voltage shutdown above 26 V.

LOGIC TRUTH TABLE

Source Driver, Pin 2	Sink Driver, Pin 5	Output, Pin 4
Low	Low	High
Low	High	High
High	Low	Low
High	High	High Z

FUNCTIONAL BLOCK DIAGRAM

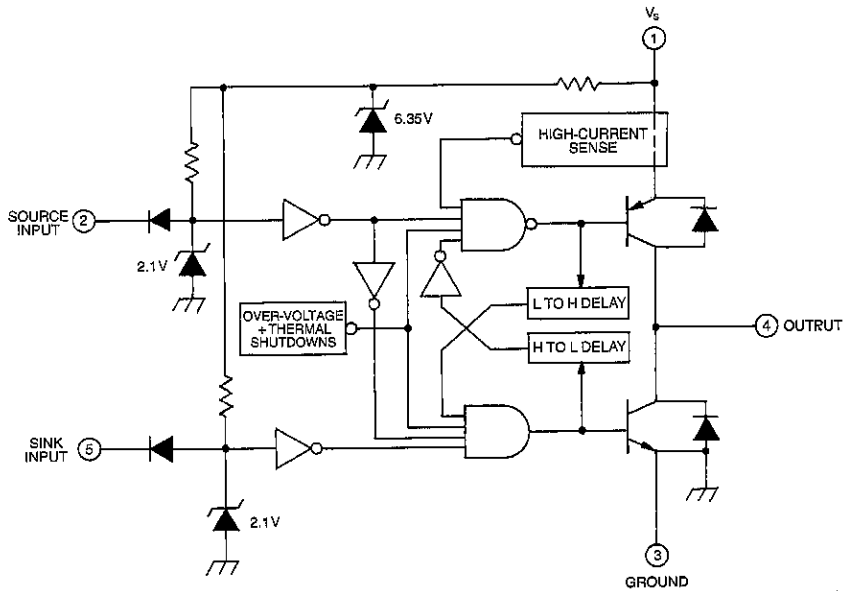

Dwg. No. A-14,138

ELECTRICAL CHARACTERISTICS at $T_A = +25^\circ\text{C}$, $T_{TAB} = 70^\circ\text{C}$, $V_S = 24\text{ V}$ (unless otherwise noted)

Characteristic	Symbol	Source Driver Input, Pin 2	Sink Driver Input, Pin 5	Output, Pin 4	Other	Limits			Units
						Min.	Typ.	Max.	
Output Leakage Current	I_{CEX}	2.4 V	2.4	0 V	—	—	-10	-100	μA
		2.4 V	2.4 V	45 V	—	—	10	100	μA
Output Sustaining Voltage	$V_{CE(SUS)}$	2.4 V	0.8 to 2.4 V	1.0 A	Fig. 1A	24	—	—	V
		0.8 to 2.4 V	2.4 V	-1.0 A	Fig. 1B	24	—	—	V
Output Saturation Voltage	$V_{CE(SAT)}$	0.8 V	2.4 V	-1.0 A	—	—	1.2	1.8	V
		2.4 V	0.8 V	1.0 A	—	—	0.6	1.0	V
Short-Circuit Source Current	I_{SC}	0.8 V	2.4 V	0 V	—	1.1	—	1.8	A
Logic Input Voltage	$V_{IN(L)}$	—	—	—	—	2.0	—	—	V
	$V_{IN(O)}$	—	—	—	—	—	—	0.8	V
Input Current	$I_{IN(L)}$	2.4 V	2.4 V	NC	—	—	10	100	μA
	$I_{IN(O)}$	0.8 V	0.8 V	NC	—	—	-50	-150	μA
Clamp Diode Forward Voltage	V_F	NC	NC	1.0 A	Fig. 2	—	1.5	2.0	V
Logic Supply Current	I_S	2.4 V	2.4 V	NC	—	—	15	20	mA
		2.4 V	0.8 V	NC	—	—	55	70	mA
		0.8 V	2.4 V	NC	—	—	25	35	mA
Thermal Shutdown Temperature	T_J	—	—	—	—	—	160	—	$^\circ\text{C}$
Over-Voltage Shutdown	V_S	—	—	—	—	26	—	—	V
Propagation Delay	t_{PD}	2.4 V	2.4 to 0.8 V	1.0 A	Fig. 3	—	0.6	1.0	μs
		0.8 to 2.4 V	2.4 V	-1.0 A	Fig. 4	—	1.0	2.5	μs
		2.4 V	0.8 to 2.4 V	1.0 A	Fig. 3	—	1.1	2.5	μs
		2.4 to 0.8 V	2.4 V	-1.0 A	Fig. 4	—	0.6	1.0	μs
Dead Time	t_d	—	—	—	—	—	2.0	—	μs

NOTE: Positive (negative) current is defined as going into (coming out of) the specified device pin.

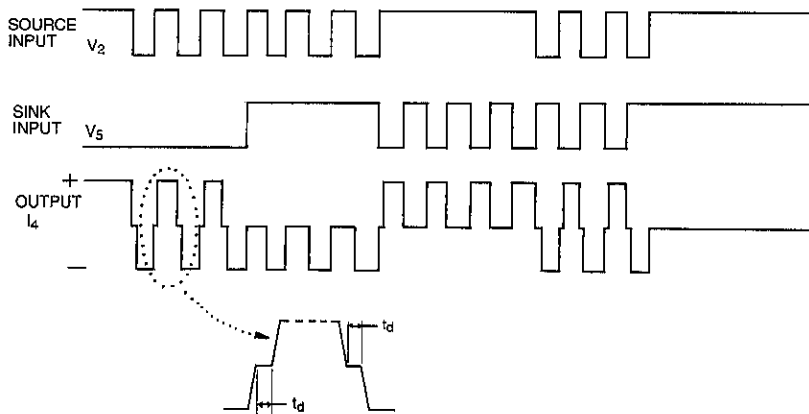

Dwg. No. A-14,137

4

**UDN-2943Z
HIGH-CURRENT HALF-BRIDGE MOTOR DRIVER**

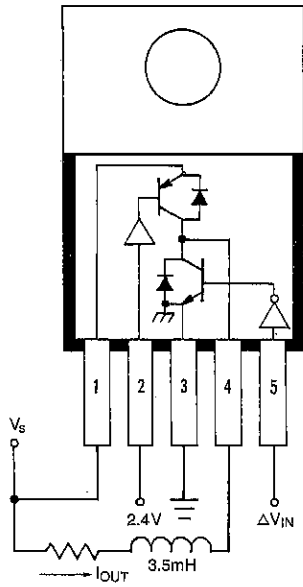

Dwg. No. A-14,138

FIGURE 1A

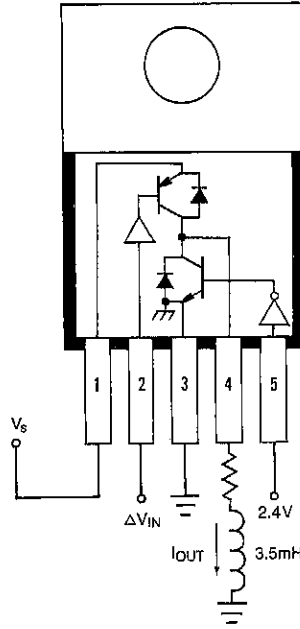

Dwg. No. A-14,139

FIGURE 1B

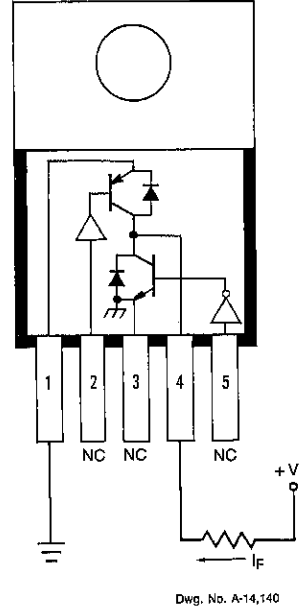

Dwg. No. A-14,140

FIGURE 2

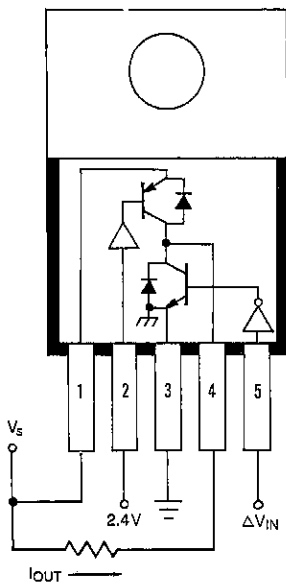

Dwg. No. A-14,141

FIGURE 3

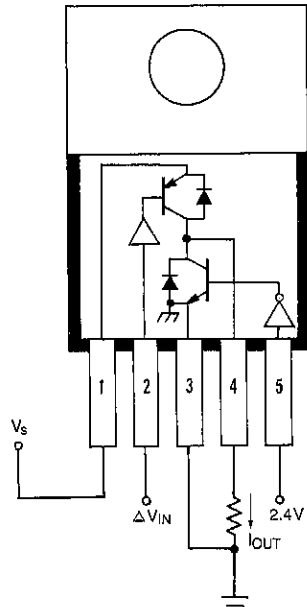

Dwg. No. A-14,142

FIGURE 4

UDN-2944W

QUAD HIGH-CURRENT, HIGH-VOLTAGE SOURCE DRIVER

FEATURES

- Output Current to 4A
- Output Voltage to 60V
- Loads to 960W
- Integral Output Suppression Diodes
- TTL and CMOS Compatible Inputs
- Plastic Single In-Line Package
- Heat-Sink Tab

Capable of driving loads to 4A at supply voltages to 60V (inductive loads to 35V), the UDN-2944W is a quad high-current, high-voltage source driver. Each of the four power drivers can provide space- and cost-saving interface between low-level signal-processing circuits and high-power loads in harsh environments.

Individual supply lines have been provided for each pair of drivers so that different supplies can be used to drive multiple loads. The controlling inputs are TTL or CMOS compatible. The outputs include transient-suppression diodes for inductive loads.

This quad Darlington array is designed to serve as an interface between low-level circuitry and peripheral-power loads such as solenoids, motors, incandescent displays, heaters, and similar loads of up to 240W per channel. The UDN-2944W is an ideal complement to the UDN-2878W quad 4A sink driver.

For maximum power-handling capability, the UDN-2944W driver is supplied in a 12-pin single

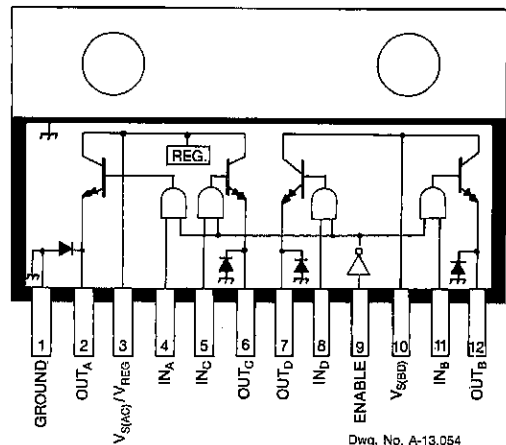

4

in-line, power-tab package that allows efficient attachment of an external heat sink for maximum allowable package power dissipation. An external heat sink is usually required for proper operation of this device. The tab is at ground potential and needs no insulation.

ABSOLUTE MAXIMUM RATINGS at +25°C Free-Air Temperature

Supply Voltage Range V_s	10 V to 60 V
Output Current, I_{OUT} (DC)	- 4 A
(Peak)	- 5 A
Input Voltage, V_{IN}	15 V
Package Power Dissipation, P_D	See Graph
Operating Temperature Range, T_A	- 20°C to + 85°C
Storage Temperature Range, T_S	- 55°C to + 150°C

Output current rating will be limited by ambient temperature, duty cycle, heat sinking, air flow, and number of outputs conducting. Under any set of conditions, do not exceed the -5.0A peak current and junction temperature of +150°C.

UDN-2944W
QUAD HIGH-CURRENT, HIGH-VOLTAGE SOURCE DRIVER

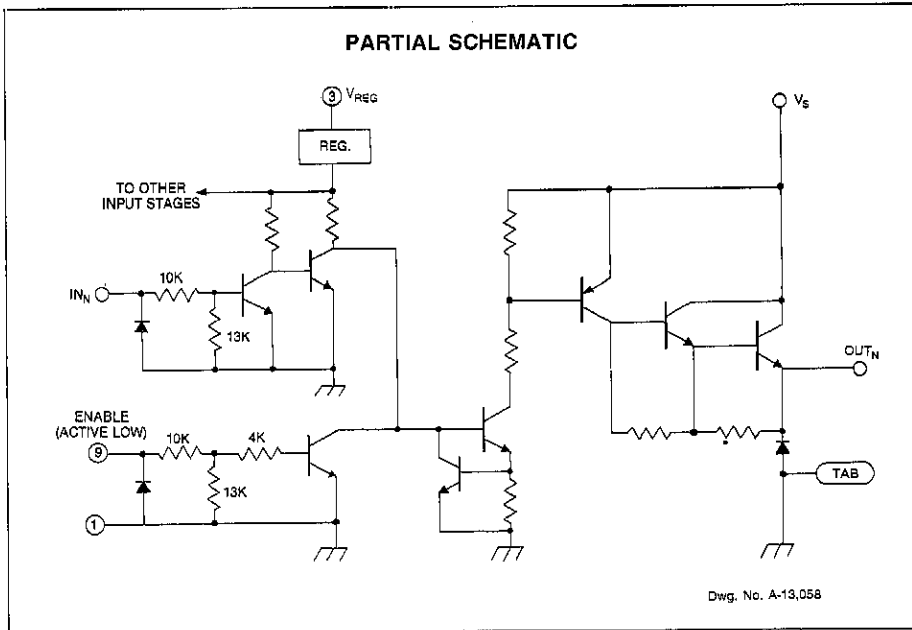

ALLOWABLE AVERAGE PACKAGE POWER DISSIPATION AS A FUNCTION OF TEMPERATURE

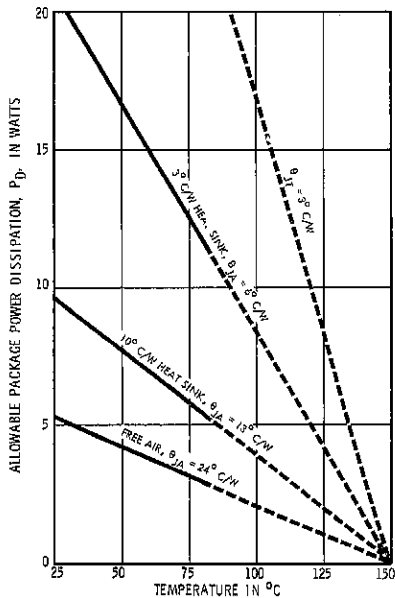

Dwg. No. A-11,794A

NOTE: Pin 3 must be connected to V_S for operation of input logic gates.

TRUTH TABLE

Input	Enable	Output
L	L	L
H	L	H
L	H	L
H	H	L

ELECTRICAL CHARACTERISTICS at $T_A = +25^\circ\text{C}$, $T_{TAB} \leq 70^\circ\text{C}$, $V_S = 60\text{V}$, $V_{ENABLE} = 0\text{V}$
(unless otherwise noted)

Characteristic	Symbol	Test Conditions	Limits		
			Min.	Max.	Units
Supply Voltage Range	V_S		10	60	V
Output Leakage Current	I_{CEX}	$V_{OUT} = 0\text{V}$, $V_{ENABLE} = 2.4\text{V}$	—	50	μA
Output Sustaining Voltage	$V_{CE(SUS)}$	$I_{OUT} = -4\text{A}$, $L = 3\text{mH}$	35	—	V
Output Saturation Voltage	$V_{CE(SAT)}$	$I_{OUT} = -1\text{A}$, $V_{IN} = 2.4\text{V}$	—	1.8	V
		$I_{OUT} = -4\text{A}$, $V_{IN} = 2.4\text{V}$	—	2.5	V
Input Voltage	Logic 1	$V_{IN(1)}$ or $V_{ENABLE(1)}$	2.0	—	V
	Logic 0	$V_{IN(0)}$ or $V_{ENABLE(0)}$	—	0.8	V
Input Current	Logic 1	$V_{IN(1)}$ or $V_{ENABLE(1)} = 2.4\text{V}$	—	220	μA
		$V_{IN(1)}$ or $V_{ENABLE(1)} = 12\text{V}$	—	1.5	mA
	Logic 0	$V_{IN(0)}$ or $V_{ENABLE(0)} = 0.8\text{V}$	—	50	μA
Total Supply Current	I_S	All drivers ON, All outputs open	—	25	mA
Clamp Diode Leakage Current	I_R	$V_R = 60\text{V}$	—	50	μA
Clamp Diode Forward Voltage	V_F	$I_F = 4\text{A}$	—	2.2	V
Turn-On Delay	t_{ON}	$0.5 E_{in}$ to $0.5 E_{out}$, $R_L = 15\Omega$	—	2.0	μs
Turn-Off Delay	t_{OFF}	$0.5 E_{in}$ to $0.5 E_{out}$, $R_L = 15\Omega$	—	10	μs

NOTE: Negative current is defined as coming out of (sourcing) the device being tested.

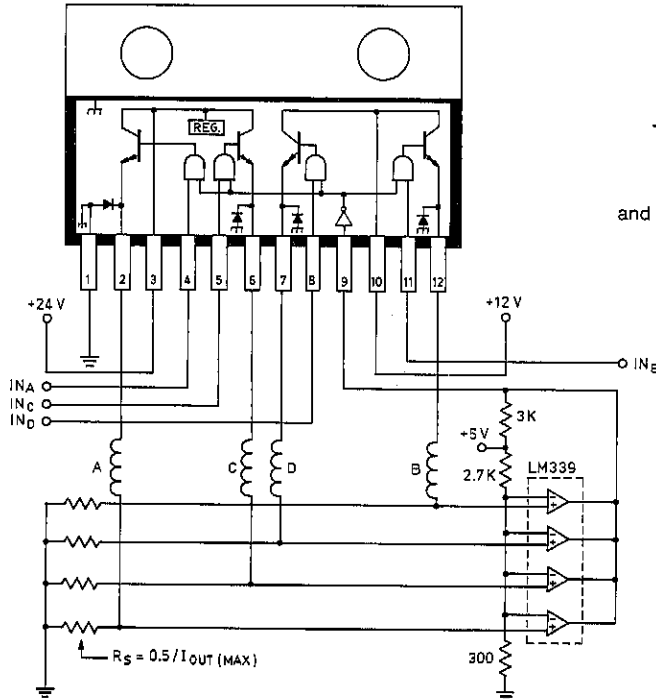

TYPICAL APPLICATION
QUAD RELAY DRIVE
Using 2 Voltage Sources
and Optional PWM Current Limiting



UDN-2948W QUAD HIGH-CURRENT, HIGH-VOLTAGE SOURCE DRIVER

FEATURES

- Output Current to 6 A per Channel
- Output Voltage to 60 V
- Integral Output Suppression Diodes
- TTL and CMOS Compatible Inputs
- Plastic Single In-Line package
- Heat Sink Tab

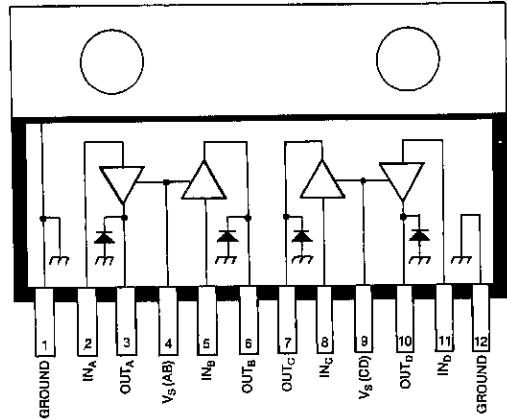

Dwg. No. A-13.055

Providing space and cost-saving interface between microprocessor/LSI circuits and high-power peripheral loads such as solenoids, dc or stepper motors, incandescent displays, heaters, and similar loads, the UDN-2948W quad high-current, high-voltage source driver can drive loads to -6 A at supply voltages to 60 V (inductive loads to 35 V). The low-level inputs are TTL or CMOS compatible. The outputs include transient-suppression diodes for inductive loads. Individual supply lines are provided for each pair of drivers so that different supplies can be used to drive multiple loads.

The application of source drivers for X-Y addressing of multiplexed power loads are obvious. A more subtle advantage of high-current source drivers is with inductive loads or incandescent lamps. Both types of load normally generate

troublesome transients and noise currents on common logic/load ground lines. In addition, high ground currents produce IR drops that can shift the ground rail, affecting logic input levels, thresholds, and noise immunity. The use of source drivers can minimize many of these concerns by separating the logic and power returns.

For maximum allowable package power capability, the UDN-2948W driver is supplied in a 12-pin single in-line, power-tab package that allows efficient attachment of an external heat sink. The external heat sink is usually required for proper operation of this device. The heat sink tab is at ground potential and needs no insulation.

Similar 4 A devices with an input ENABLE control are supplied as the UDN-2944W.

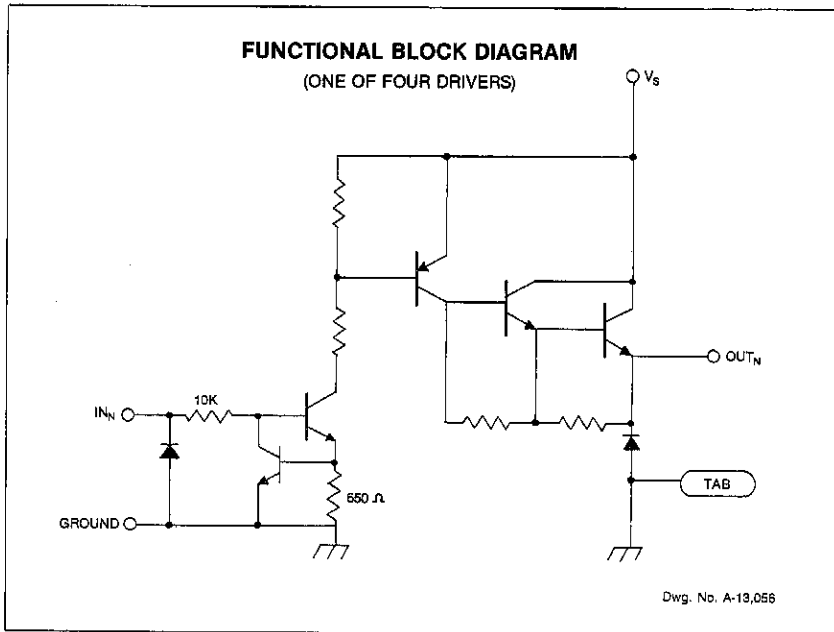

4

**ALLOWABLE AVERAGE PACKAGE POWER DISSIPATION
 AS A FUNCTION OF TEMPERATURE**

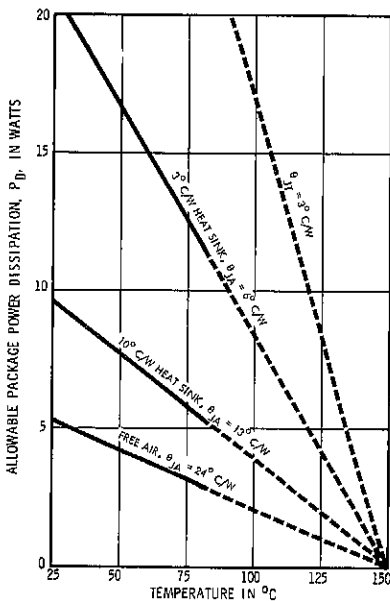

Dwg. No. A-11,794A

ABSOLUTE MAXIMUM RATINGS
 at +25°C Free-Air Temperature

- Supply Voltage Range, V_S 5.0V to 60V
- Output Sustaining Voltage, $V_{CE(sus)}$ Min. 35V
- Output Current, I_{OUT} (dc) -6A
- (peak) -7A
- Input Voltage, V_{IN} 15V
- Package Power Dissipation, P_D 5.2W*
- Operating Temperature Range, T_A -20°C to +85°C
- Storage Temperature Range, T_S -55°C to +150°C

*Derate at the rate of 41.6 mW/°C above $T_A = +25^\circ\text{C}$.

Output current rating will be limited by ambient temperature, duty cycle, heat sinking, air flow, and number of outputs conducting. Under any set of conditions, do not exceed the -7.0A peak current and a junction temperature of +150°C.

**ELECTRICAL CHARACTERISTICS at $T_A = +25^\circ\text{C}$, $T_{TAB} \leq 70^\circ\text{C}$, $V_S = 60\text{ V}$,
(unless otherwise noted)**

Characteristic	Symbol	Test Conditions	Limits		
			Min.	Max.	Units
Supply Voltage Range	V_S		5.0	60	V
Output Leakage Current	I_{CEX}	$V_{OUT} = 0\text{ V}$, $V_{IN} = 0.4\text{ V}$	—	50	μA
Output Sustaining Voltage	$V_{CE(SUS)}$	$I_{OUT} = -6\text{ A}$, $L = 3\text{ mH}$	35	—	V
Output Saturation Voltage	$V_{CE(SAT)}$	$I_{OUT} = -1\text{ A}$, $V_{IN} = 2.4\text{ V}$	—	1.8	V
		$I_{OUT} = -4\text{ A}$, $V_{IN} = 2.4\text{ V}$	—	2.2	V
		$I_{OUT} = -6\text{ A}$, $V_{IN} = 2.4\text{ V}$	—	2.6	V
Input Voltage	$V_{IN(ON)}$		2.4	—	V
	$V_{IN(OFF)}$		—	0.8	V
Input Current	$I_{IN(ON)}$	$V_{IN} = 2.4\text{ V}$	—	220	μA
		$V_{IN} = 12\text{ V}$	—	1.5	mA
	$I_{IN(OFF)}$	$V_{IN} = 0.8\text{ V}$	—	10	μA
Total Supply Current	I_S	One Driver ON, All Outputs Open	—	1.8	mA
Clamp Diode Leakage Current	I_R	$V_R = 60\text{ V}$	—	50	μA
Clamp Diode Forward Voltage	V_F	$I_F = 6\text{ A}$	—	2.9	V
Turn-On Delay	t_{ON}	$0.5 E_{in}$ to $0.5 E_{out}$, $R_L = 15$	—	2.0	μs
Turn-Off Delay	t_{OFF}	$0.5 E_{in}$ to $0.5 E_{out}$, $R_L = 15$	—	10	μs

NOTE: Negative current is defined as coming out of (sourcing) the device being tested.

APPLICATION NOTES

Power-tab packages are efficient thermal dissipators when properly utilized. In application, the following precautions should be taken:

1. Always fasten the tab to the heat sink before the leads are soldered to fixed terminals.
2. Use appropriate hardware including a lock washer or torque washer.
3. Thermal grease (Dow Corning 340 or equivalent) should always be used.
4. Mounting torque should be between 4 and 8 inch pounds (0.45 to 0.90 Nm.)
5. The mounting hole should be as clean as possible with no burrs or ridges.
6. The mounting surface should be flat to within 0.002 inch/inch (0.05 mm/mm).
7. Strain relief must be provided if there is any probability of axial stress to the leads.
8. If insulating bushings are used, they should be of dialylphthalate, fiberglass-filled polycarbonate, or fiberglass-filled nylon. Unfilled nylon should be avoided.

UDN-2951Z AND UDN-2955W 8 A HALF-BRIDGE MOTOR DRIVERS

FEATURES

- 8 A Output Capability (DC)
- 50 V Operating Range
- Thermal Shutdown Circuitry
- Built-In Crossover Delays
- Disable and Emitter-Sense pins (UDN-2955W)
- Overvoltage Protection
- TTL, CMOS, PMOS, NMOS Compatible Inputs
- Internal Linear-Overcurrent Limiter

The UDN-2951Z and UDN-2955W half-bridge motor drivers can handle 8 A continuous load currents and output voltages up to 50 V. Both devices feature TTL, CMOS, PMOS, and NMOS compatible inputs, level shifting, and an internal voltage regulator for single-supply operation. Output transient-suppression diodes in both sink and source drivers have been incorporated.

The UDN-2951Z and UDN-2955W both have internal delay times to guard against hazardous crossover currents. Both devices maintain internal current limiting, overvoltage protection up to 75 V, and thermal shutdown at 165°C.

The UDN-2955W has extended flexibility with an external emitter sense pin on the sink driver, separate

rated sink and source outputs, and a DISABLE input that can be used in high-speed chopper applications.

The UDN-2951Z is supplied in a TO-220 power-tab package for enhanced power dissipation capabilities and minimal size. The UDN-2955W is supplied in a 12-pin single in-line plastic power-tab package for exceptional power handling capabilities. This power-tab configuration allows for easy attachment of an external heat-sink for extended power-handling capabilities.

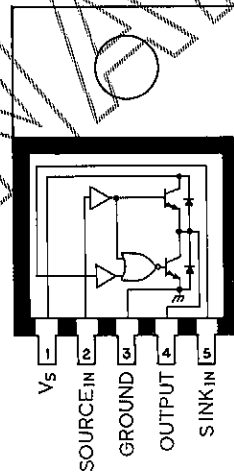
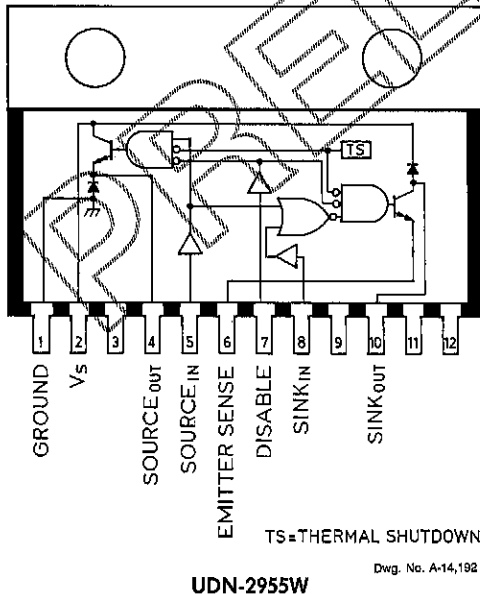

ABSOLUTE MAXIMUM RATINGS at $T_A = +25^\circ\text{C}$

Supply Voltage Range, V_S	10 V to 75 V†
Output Voltage Range, V_{OUT}	0 V to 50 V
Output Current, I_{OUT} (DC)	8 A
Input Voltage Range, V_{IN}	-0.7 V to 9.0 V
Package Power Dissipation, P_D	
(Z Package)	3.125 W*
(W Package)	5.2 W**
Operating Temperature Range, T_A	-20°C to +85°C
Storage Temperature Range, T_S	-55°C to +150°C

*Derate at the rate of 25 mW/°C above $T_A = +25^\circ\text{C}$.

**Derate at the rate of 41.66 mW/°C above $T_A = +25^\circ\text{C}$.

†Internal over-voltage shutdown above 50 V.

FUNCTIONAL BLOCK DIAGRAM

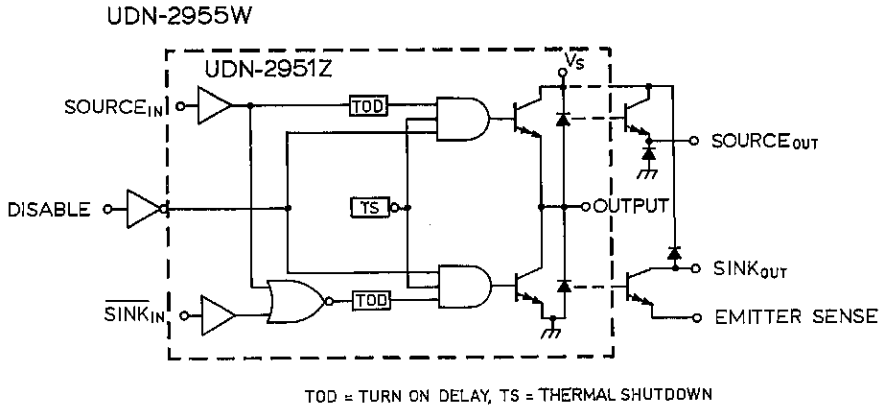

Dwg. No. A-14,190

ELECTRICAL CHARACTERISTICS at $T_A = +25^\circ\text{C}$, $V_S = 50\text{ V}$, DISABLE (UDN-2955W) = 0 V

Characteristic	Symbol	Conditions	Limits			Units
			Min.	Typ.	Max.	
Output Leakage Current	I_{CEX}	$V_{OUT} = 50\text{ V}$	—	—	50	μA
		$V_{OUT} = 0\text{ V}$	—	—	-50	μA
Output Sustaining Voltage	$V_{CE(SUS)}$	$i_{OUT} = \pm 8\text{ A}$, $L = 3\text{ mH}$	50	—	—	V
Output Saturation Voltage	$V_{CE(SAT)}$	$I_{OUT} = \pm 8\text{ A}$	—	—	2.0	V
Short-Circuit Source Current	I_{OUT}		-8.0	—	-12	A
Input Current	$I_{IN(1)}$	$V_{IN} = 2.0\text{ V}$	—	—	0.5	mA
	$I_{IN(0)}$	$V_{IN} = 0.8\text{ V}$	-6.0	—	—	μA
Propagation Delay	t_{PHL}	$I_{OUT} = 8\text{ A}$, Resistive Load, Sink Driver	—	2.5	—	μs
	t_{PLH}	$I_{OUT} = 8\text{ A}$, Resistive Load, Sink Driver	—	0.2	—	μs
	t_{PHL}	$I_{OUT} = -8\text{ A}$, Resistive Load, Source Driver	—	2.5	—	μs
	t_{PLH}	$I_{OUT} = -8\text{ A}$, Resistive Load, Source Driver	—	2.5	—	μs
Clamp Diode Forward Voltage	V_F	$I_F = 8\text{ A}$	—	2.0	—	V
Clamp Diode Leakage Current	I_R	$V_R = 50\text{ V}$	—	—	50	μA
Supply Current	I_S	$V_{SOURCE} = 2.0\text{ V}$	—	—	12	mA
		$V_{SINK} = V_{SOURCE} = 0.8\text{ V}$	—	—	20	mA
Thermal Shutdown Temperature	T_J	Note 1	—	165	—	$^\circ\text{C}$
Over-Voltage Shutdown	V_S		50	—	60	V

1. Thermal shutdown has a typical hysteresis of 15 $^\circ\text{C}$.

TYPICAL APPLICATION

3-PHASE BRUSHLESS DC MOTOR DRIVE

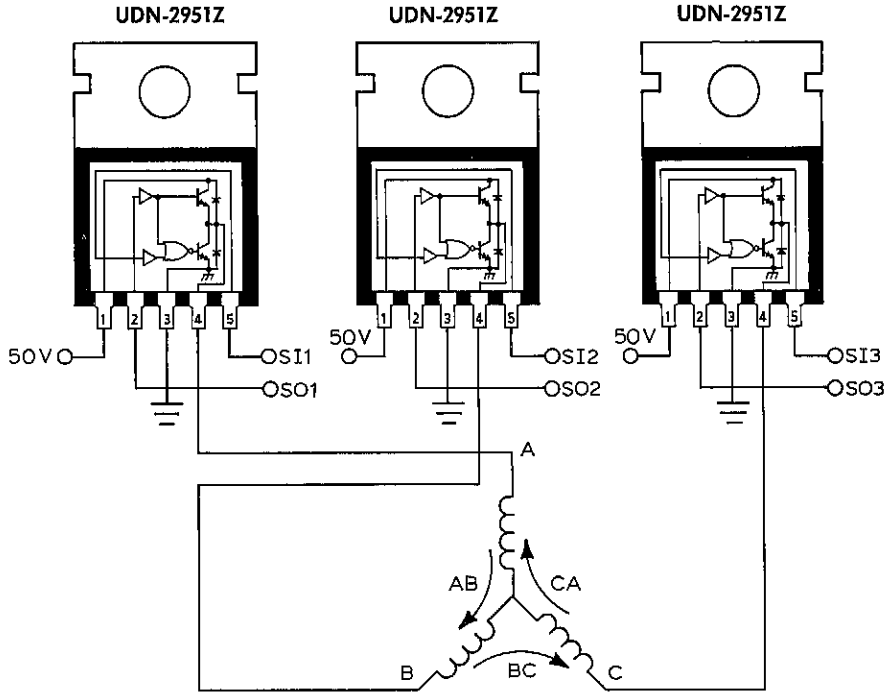

Dwg. No. A-14,144

4

INPUT WAVEFORMS

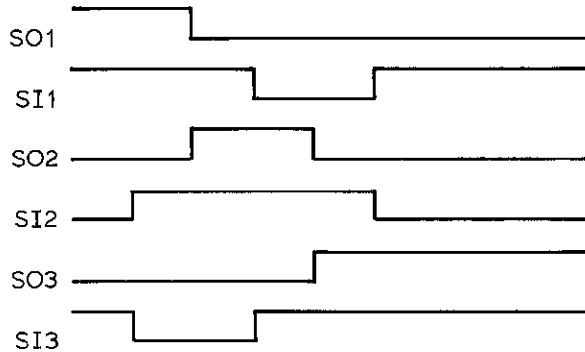

Dwg. No. A-14,145

UDN-2952B AND UDN-2952W FULL-BRIDGE MOTOR DRIVERS

FEATURES

- High Output Current
- Adjustable Short-Circuit Protection
- Thermal Protection
- Internal Clamp Diodes
- TTL, DTL, PMOS, CMOS Compatible
- DIP or SIP Packaging

FULL-BRIDGE MOTOR-DRIVER integrated circuits, Types UDN-2952B and UDN-2952W combine low-level logic circuitry and Darlington output power drivers for bidirectional control of d-c motors or solenoids operating with continuous load currents of up to 2A and peak start-up currents as high as 3.5A.

For applications requiring load currents of 1A or less (2A peak), the economical Type UDN-2952B-2 and UDN-2952W-2 are recommended. The lower-

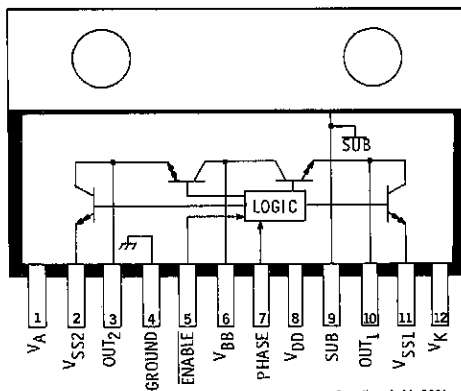

UDN-2952W

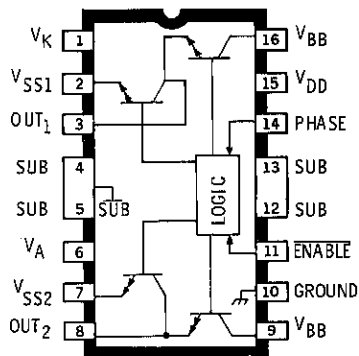

UDN-2952B

cost devices are identical to the basic parts, except for the maximum allowable load-current rating.

These monolithic integrated circuits have extensive circuit protection. Both drivers have thermal shutdown networks that disable motor drive if the package power dissipation ratings are exceeded. Internal diode transient suppression is provided on-chip. Output-current limiting is determined by the user's selection of a sensing resistor.

The Type UDN-2952B full-bridge power driver is supplied in a 16-pin dual in-line plastic package with copper heat-sink contact tabs. The lead configuration enables easy attachment of a heat sink while fitting a standard integrated circuit socket or printed wiring board layout. Type UDN-2952W, for higher power requirements, is in a 12-pin single in-line power tab package. The tab is at ground potential and needs no insulation. For output currents above 700 mA at normal ambient temperatures, both drivers require an external heat sink.

ABSOLUTE MAXIMUM RATINGS

at $T_{TAB} = +70^{\circ}\text{C}$

Motor Supply Voltage Range, V_{BB}	4.5V to 40V
Logic Supply Voltage Range, V_{DD}	4.5V to 15V
Substrate Voltage Range, V_{SUB}	0V to -20V
Logic Input Voltage, V_{PHASE} or V_{ENABLE}	30V
Output Current, I_{OUT} (UDN-2952B and UDN-2952W)	$\pm 3.5\text{A}$
(UDN-2952B-2 and UDN-2952W-2)	$\pm 2\text{A}$
Package Power Dissipation, P_D	See Graphs
Operating Temperature Range, T_A	-20°C to $+85^{\circ}\text{C}$
Storage Temperature Range, T_S	-55°C to $+150^{\circ}\text{C}$

TRUTH TABLE

ENABLE	PHASE	V_{SS}	V_{DD}	OUT ₁	OUT ₂
High	X	X	X	Open	Open
Low	High	$<0.8\text{V}$	$>4.5\text{V}$	High	Low
Low	Low	$<0.8\text{V}$	$>4.5\text{V}$	Low	High
X	X	$>0.9\text{V}$	$>4.5\text{V}$	Open	Open
X	X	X	0V	Open	Open

X = Irrelevant.

**ELECTRICAL CHARACTERISTICS at $T_A = +25^{\circ}\text{C}$, $V_{BB} = 40\text{V}$, $V_{DD} = 5\text{V}$, $T_{TAB} \leq +70^{\circ}\text{C}$,
Figure 1 (unless otherwise noted)**

Characteristic	Symbol	Test Conditions	Limits			
			Min.	Typ.	Max.	Units
Output Drivers (OUT₁ or OUT₂)						
Output Leakage Current	I_{CEX}	$V_{ENABLE} = 5\text{V}$, $V_{OUT} = V_{BB}$, Note 1	—	—	500	μA
		$V_{ENABLE} = 5\text{V}$, $V_{OUT} = 0\text{V}$, Note 1	—	—	-500	μA
Output Saturation Voltage	$V_{CE(SAT)}$	$V_{ENABLE} = 0\text{V}$, $I_{OUT} = 1\text{A}$, Notes 1 and 2	—	1.2	1.5	V
		$V_{ENABLE} = 0\text{V}$, $I_{OUT} = 2\text{A}$, Notes 1 and 3	—	1.5	2.0	V
Output Sustaining Voltage	$V_{CE(SUS)}$	$I_{OUT} = 1\text{A}$, Figure 2, Notes 1 and 2	40	—	—	V
		$I_{OUT} = 2\text{A}$, Figure 2, Notes 1 and 3	40	—	—	V
Motor Supply Current	$I_{BB(ON)}$	$V_{ENABLE} = 0.8\text{V}$, Outputs Open, Note 1	—	15	30	mA
		$V_{ENABLE} = 2.4\text{V}$, Outputs Open, Note 1	—	3.0	5.0	mA
Clamp Diode Forward Voltage	V_F	$I_F = 1\text{A}$, Note 2	—	1.0	1.5	V
		$I_F = 2\text{A}$, Note 3	—	1.8	2.2	V

Control Logic (PHASE or ENABLE)

Logic Open-Circuit Voltage	V_{IN}	I_{PHASE} or $I_{ENABLE} = -250\ \mu\text{A}$	—	—	7.5	V
Logic Input Current	$I_{IN(L)}$	V_{PHASE} or $V_{ENABLE} = 2.4\text{V}$	—	-50	-100	μA
		V_{PHASE} or $V_{ENABLE} = 0.8\text{V}$	—	-1.0	-1.6	mA
Logic Input Voltage	$V_{IN(L)}$		2.4	—	—	V
			—	—	0.8	V
Logic Supply Current	I_{DD}		—	15	30	mA
Sense Trigger Voltage	V_{SS}	$V_{ENABLE} = 0.8\text{V}$	—	850	—	mV
Turn-On Delay Time	t_{pd0}	Source Drivers	—	1.0	—	μs
		Sink Drivers	—	0.5	—	μs
Turn-Off Delay Time	t_{pd1}	Source Drivers	—	2.0	—	μs
		Sink Drivers	—	1.0	—	μs
Thermal Shutdown	T_J		—	175	—	$^{\circ}\text{C}$

- NOTES: 1. Test is performed with $V_{PHASE} = 0.8\text{V}$ and then repeated for $V_{PHASE} = 2.4\text{V}$.
2. Output measurement at 1A are applicable to the UDN-2952B, UDN-2952B-2, UDN-2952W, and UDN-2952W-2.
3. Output measurements at 2A are applicable only to the UDN-2952B and UDN-2952W.



**UDN-2952B AND UDN-2952W
FULL-BRIDGE MOTOR DRIVERS**

FUNCTIONAL BLOCK DIAGRAM

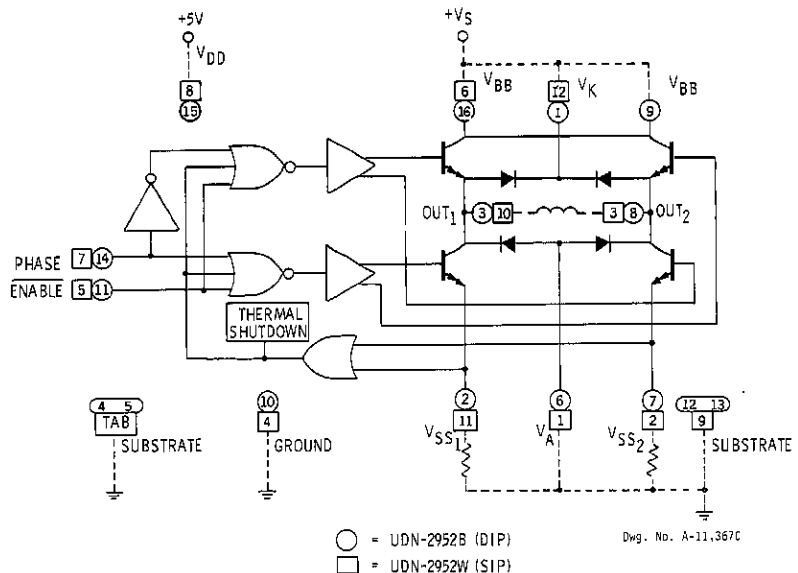

**ALLOWABLE AVERAGE PACKAGE POWER DISSIPATION
AS A FUNCTION OF TEMPERATURE**

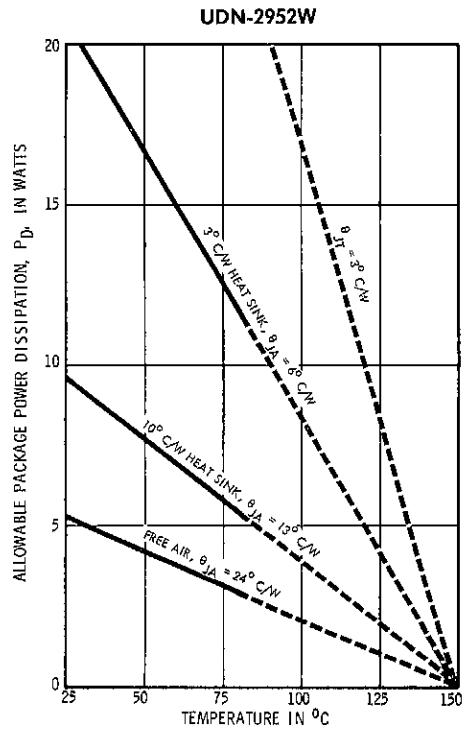
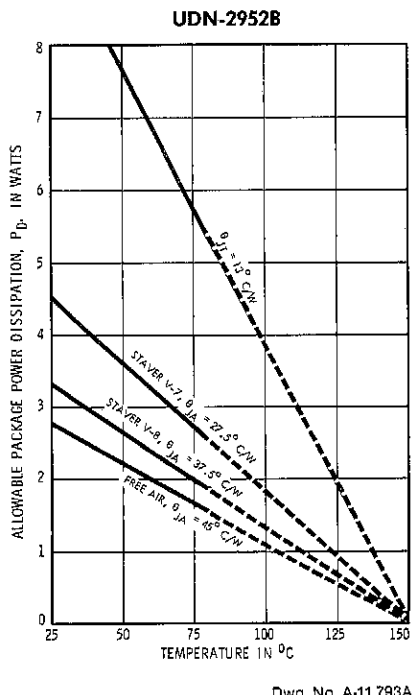

TEST FIGURES

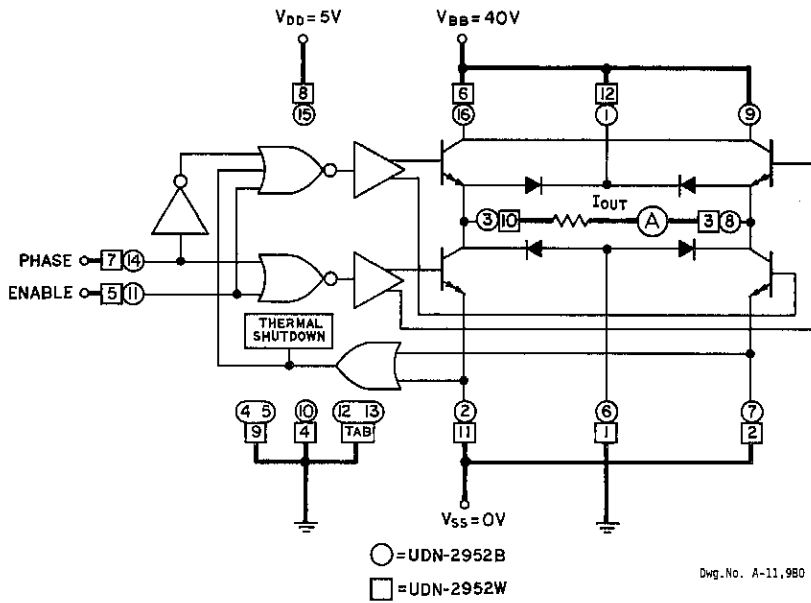

FIGURE 1

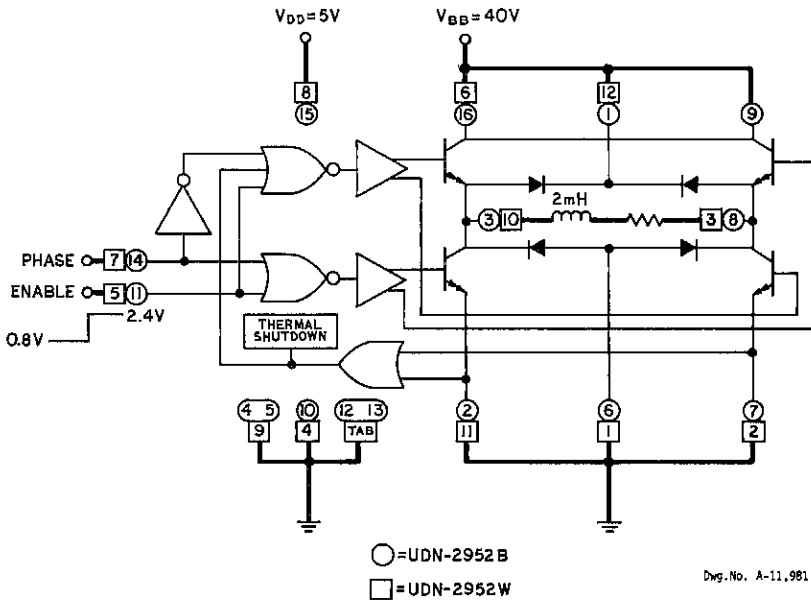
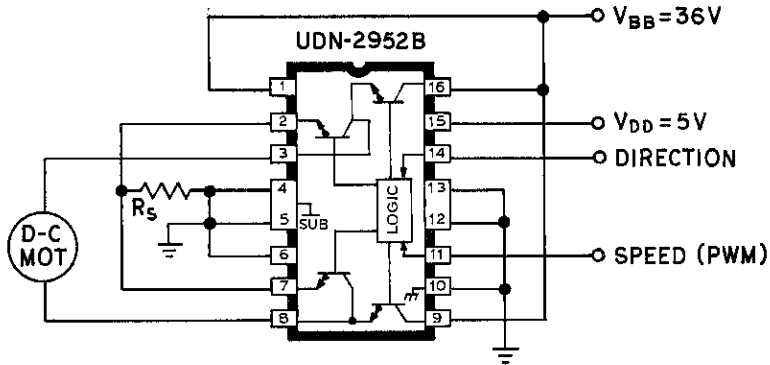

FIGURE 2

TYPICAL APPLICATIONS

FULL-BRIDGE DC SERVO MOTOR APPLICATION



Dwg. No. A-11,984

4

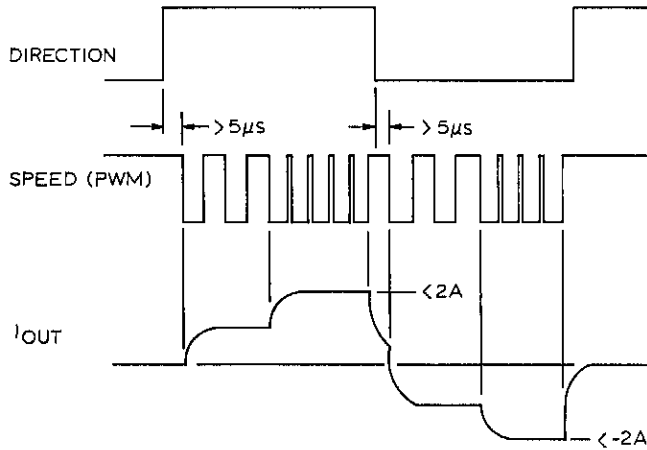

Dwg. No. A-11,983

UDN-2953B AND UDN-2954W FULL-BRIDGE PWM MOTOR DRIVERS

FEATURES

- 50 V Output Voltage Rating
- 2 A Continuous Output Rating
- Internal Flyback Diodes
- Thermal Shutdown
- Crossover Current Protection
- BRAKE, ENABLE, and Current-Limit Functions

The UDN-2953B and UDN-2954W are designed for bidirectional control of dc or stepper motors with continuous output currents to 2 A and peak start-up currents as high as 3.5 A. For pulse-width modulated (chopped-mode) operation, the output current is determined by the user's selection of a reference voltage and sensing resistor while the OFF pulse duration is set by an external RC timing network. PWM operation is character-

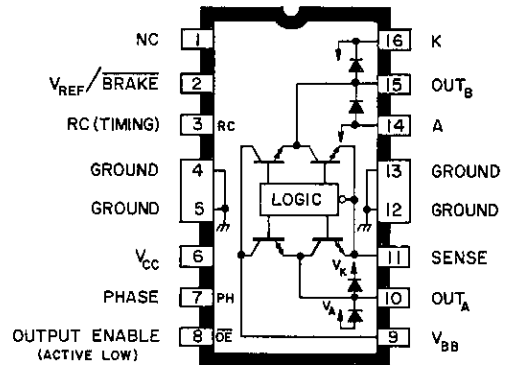

Dwg. No. A-13,024

UDN-2953B

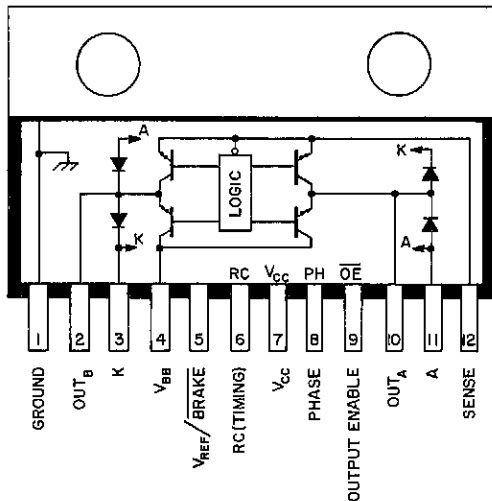

Dwg. No. A-13,023

UDN-2954W

ized by maximum efficiency and low power-dissipation levels. Extensive internal circuit protection includes thermal shutdown with hysteresis, transient-suppression diodes, and crossover current protection.

When the $V_{REF}/BRAKE$ pin is low (<0.8 V, the-braking function is enabled. This turns both sink drivers OFF and the source drivers are turned ON. When $V_{REF}/BRAKE$ is set above 2.4 V, that voltage (and the current sensing resistor) determines the load current trip point. An RC TIMING pin is available to use for an internal one-shot to control load current decay time.

The UDN-2953B driver is supplied in a 16-pin dual-in-line plastic package with copper heat-sink contact tabs. The lead configuration enables easy attachment of a heat sink while fitting a standard integrated circuit socket or printed wiring board layout. The UDN-2954W, for higher package power dissipation requirements, is supplied in a 12-pin single in-line power tab package. In both package styles, the heat sink is at ground potential and needs no insulation.

ABSOLUTE MAXIMUM RATINGS

at $T_{TAB} \leq +70^{\circ}\text{C}$

Motor Supply Voltage, V_{BB}	50 V
Output Current, I_{OUT} (Peak)	± 3.5 A
(Continuous)	± 2.0 A
Flyback Diode Voltage, V_K	V_{BB}
Minimum Clamp Diode Voltage, V_A	Ground
Logic Supply Voltage, V_{CC}	7.0 V
Logic Input Voltage, V_{PHASE}, V_{ENABLE}	V_{BB}
Sense Voltage, V_{SENSE}	1.5 V
Reference Voltage, $V_{REF}/\overline{\text{BRAKE}}$	15 V
Package Power Dissipation, P_D	See Graphs
Operating Temperature Range, T_A	-20°C to $+85^{\circ}\text{C}$
Storage Temperature Range, T_S	-55°C to $+150^{\circ}\text{C}$

ELECTRICAL CHARACTERISTICS at $T_A = +25^{\circ}\text{C}$, $T_{TAB} \leq +70^{\circ}\text{C}$, $V_{BB} = 50\text{ V}$, $V_{CC} = 5\text{ V}$, $V_{SENSE} = 0\text{ V}$, 5 k Ω RC to Ground

Characteristic	Symbol	Test Conditions	Limits			
			Min.	Typ.	Max.	Units
Output Drivers (OUT_A or OUT_B)						
Output Supply Range	V_{BB}		6.5	—	50	V
Output Leakage Current	I_{CEX}	$V_{ENABLE} = 5\text{ V}, V_{OUT} = V_{BB}$, (note)	—	—	50	μA
		$V_{ENABLE} = 5\text{ V}, V_{OUT} = 0\text{ V}$, (note)	—	—	50	μA
Output Sustaining Voltage	$V_{CE(SUS)}$	$I_{OUT} = \pm 2\text{ A}, L = 2\text{ mH}$	50	—	—	V
Output Saturation Voltage	$V_{CE(SAT)}$	$V_{ENABLE} = 0\text{ V}, I_{OUT} = \pm 0.5\text{ A}$	—	1.0	1.2	V
		$V_{ENABLE} = 0\text{ V}, I_{OUT} = \pm 1.0\text{ A}$	—	1.2	1.4	V
		$V_{ENABLE} = 0\text{ V}, I_{OUT} = \pm 2.0\text{ A}$	—	1.5	1.8	V
Clamp Diode Leakage Current	I_R	$V_R = 50\text{ V}$	—	—	50	μA
Clamp Diode Forward Voltage	V_F	$I_F = 2\text{ A}$	—	1.8	2.2	V
Motor Supply Current	$I_{BB(ON)}$	$V_{ENABLE} = 0.8\text{ V}, V_{REF} = 2.4\text{ V}$, No Load	—	20	30	mA
		$V_{ENABLE} = V_{REF} = 2.4\text{ V}$, No Load	—	1.7	2.5	mA
		$V_{ENABLE} = 5\text{ V}, V_{REF} = 0.8\text{ V}$, No Load	—	40	60	mA
Control Logic						
Logic Supply Range	V_{CC}		4.5	5.0	5.5	V
Logic Input Current	$I_{IN(1)}$	All Inputs = 2.4 V	—	< -1	-10	μA
		All Inputs = 0.8 V	—	-50	-200	μA
Logic Input Voltage	$V_{IN(1)}$	All Inputs	2.4	—	—	V
		All Inputs	—	—	0.8	V
V_{REF} Open-Circuit Voltage	$V_{REF(OPEN)}$	$I_{REF} = 0$	—	$V_{CC}/2$	—	V
Current Limit Threshold		V_{REF}/V_{SENSE} at Trip Point	9.5	10	10.5	—
Turn-On Delay	t_{ON}	All Drivers	—	1.0	—	μs
Turn-Off Delay	t_{OFF}	All Drivers	—	1.0	—	μs
Thermal Shutdown Temp.	T_J		—	165	—	$^{\circ}\text{C}$
Logic Supply Current	I_{CC}	$V_{ENABLE} = V_{REF} = 2.4\text{ V}$	—	15	20	mA
		$V_{ENABLE} = 0.8\text{ V}, V_{REF} = 2.4\text{ V}$	—	22	30	mA

Note: Tests performed at OUT_B with $V_{PHASE} = 0.8\text{ V}$ and at OUT_A with $V_{PHASE} = 2.4\text{ V}$

4

**UDN-2953B AND UDN-2954W
FULL-BRIDGE PWM MOTOR DRIVERS**

FUNCTIONAL BLOCK DIAGRAM

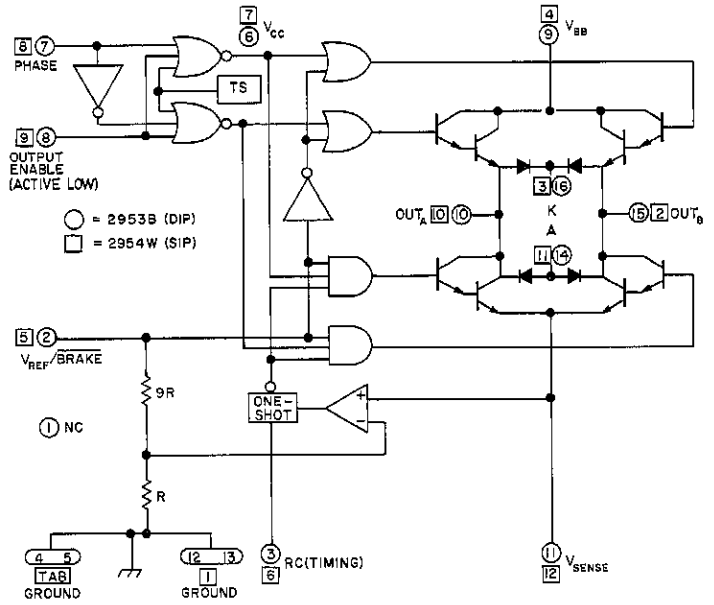

TRUTH TABLE

OUTPUT ENABLE	PHASE	V _{REF} /BRAKE	OUT _A	OUT _B
Low	High	>2.4 V	High	Low
Low	Low	>2.4 V	Low	High
High	X	>2.4 V	Open	Open
X	X	<0.8 V	High	High

X = Irrelevant.

Dwg. No. A-13,028

**ALLOWABLE POWER DISSIPATION
AS A FUNCTION OF AMBIENT TEMPERATURE**

UDN-2953B

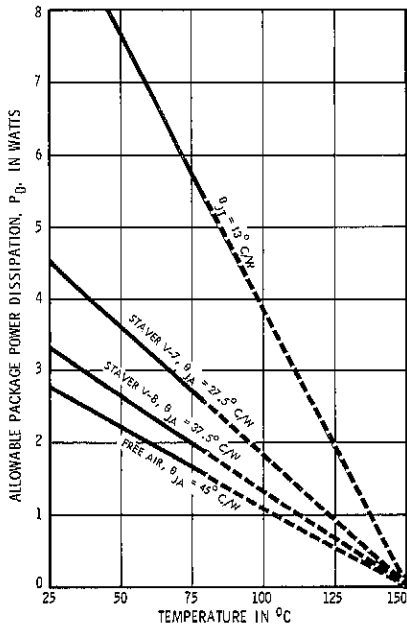

Dwg. No. A-11,793A

UDN-2954W

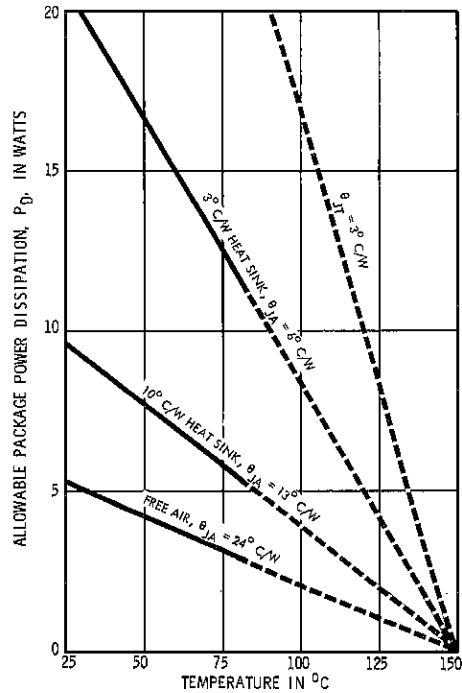

Dwg. No. A-11,794A

APPLICATIONS

The UDN-2953B and UDN-2954W full-bridge drivers are ideal for driving 2-phase bipolar stepper, bidirectional dc servo, and brushless dc motors with various pulse-width modulation (PWM) current-control formats. Output current is controlled by using an external sense resistor and an optional RC network and reference voltage for an internal fixed-frequency PWM circuit, or by using an external PWM source.

The output current trip point is set by:

$$I_{OUT} = V_{REF}/10 R_{SENSE}$$

When the current in the sense resistor (typically $\leq 0.5 \Omega$) reaches the set point, an internal one-shot turns OFF the sink drivers for a time period (t_{off}) determined by an RC time constant. The actual peak load current will be slightly higher than the trip point (especially for low-inductance loads) because of the internal logic and switching delays. This delay (t_d) is typically $2 \mu s$.

The t_{off} time interval (see Fig. 1) is approximately RC within the range of $20 \text{ k}\Omega$ to $100 \text{ k}\Omega$ and 200 pF to 500 pF . If the RC pin is tied to V_{CC} , internal delay circuitry is activated, allowing PWM operation without the external RC network. Under this condition, I_{CC} will increase approximately 6 mA . The internally-generated t_{off} is approximately $12 \mu s$ at $V_{CC} = 5 \text{ V}$ and $T_A = +25^\circ\text{C}$, increasing slightly with increasing temperatures.

For external current control, V_{REF} can be between 2.4 V and 15 V . If left unconnected, V_{REF} defaults to $V_{CC}/2$ (Fig. 2).

Average motor current can also be adjusted by external pulse-width modulation using the OUTPUT ENABLE pin. Toggling the OUTPUT ENABLE line shuts OFF both the source and sink drivers. Both the flyback and ground-clamp diodes conduct, resulting in very fast current decay. In this mode, the RC pin should be connected to ground through a $5 \text{ k}\Omega$ resistor.

With the RC pin connected to V_{CC} , V_{REF} and R_{SENSE} selected for a trip point greater than normal operation, but less than 3.5 A , over-current protection is provided (Fig. 3).

A logic low at the $V_{REF}/\overline{\text{BRAKE}}$ pin turns ON both source drivers and turns OFF both sink drivers, thus dynamically braking the motor.

An internally-generated deadtime of about $3 \mu s$ reduces crossover-currents that can occur when switching phases or braking.

Thermal protection circuitry is activated and turns OFF all drivers at a junction temperature of typically 165°C . It is only intended to protect the chip from catastrophic failures due to excessive junction temperatures. The thermal shutdown has a hysteresis of approximately 8°C .

4

TYPICAL APPLICATION

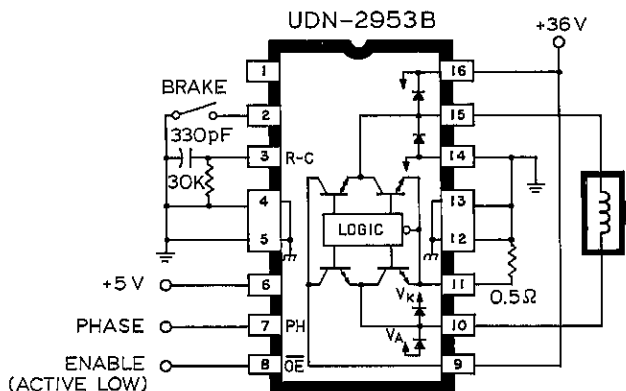

Dwg. No. A-12,649B

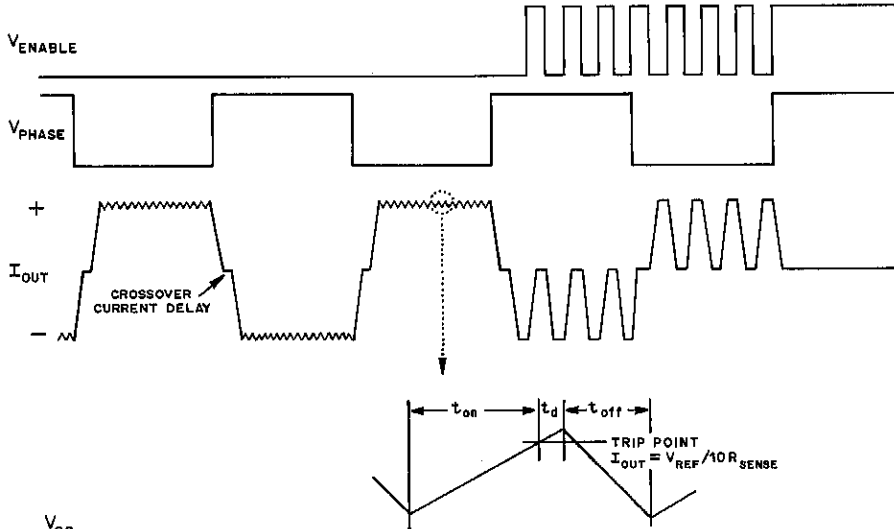
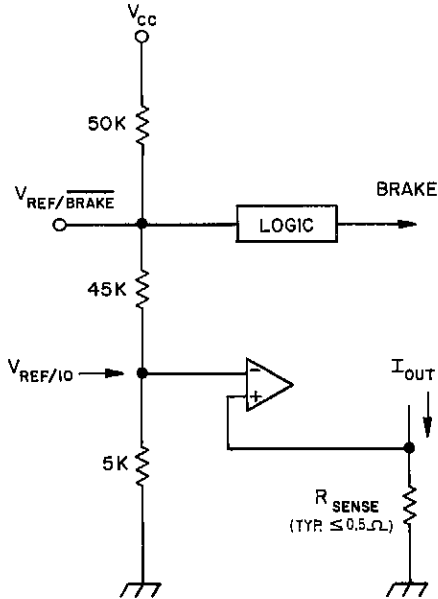

FIGURE 1

Dwg. No. A-13,027A



Dwg. No. A-13,025

FIGURE 2

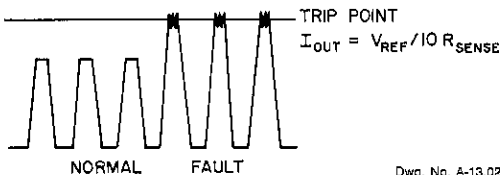

Dwg. No. A-13,026

FIGURE 3

MOUNTING OF POWER TAB DEVICES

Power-tab packages are efficient thermal dissipators when properly utilized. In application, the following precautions should be taken:

1. Always fasten the tab to the heat sink before the leads are soldered to fixed terminals.
2. Strain relief must be provided if there is any probability of axial stress to the leads.
3. Thermal grease (Dow Corning 340 or equivalent) should always be used. Thermal compounds are better heat conductors than air but not a good substitute for flat mating surfaces.
4. The mounting surface should be flat to within 0.002 inch/inch (0.05 mm/mm).
5. "Brute force" mounting to poorly finished heat sinks can cause internal stresses which damage silicon chips and insulation parts. Mounting torque should be between 4 and 8 inch pounds (0.45 to 0.90 Nm.)
6. The mounting holes should be as clean as possible with no burrs or ridges.
7. Use appropriate hardware including a lock washer or torque washer.
8. If insulating bushings are used, they should be of diallyphthalate, fiberglass-filled polycarbonate, or fiberglass-filled nylon. Unfilled nylon should be avoided.

UDN-2962B AND UDN-2962W DUAL SOLENOID/MOTOR DRIVERS Pulse-Width Modulated Current Control

FEATURES

- 4 A Peak Output
- 45 V Min. Sustaining Voltage
- Internal Clamp Diodes
- TTL/PMOS/CMOS Compatible Inputs
- High-Speed Chopper
- DIP or SIP Packaging

Using PWM to minimize power dissipation and maximize load efficiency, the UDN-2962B and UDN-2962W dual drivers are recommended for impact printer solenoids and stepper motors. Each device is comprised of two source/sink driver pairs rated for continuous operation to $\pm 3A$. They can be connected to drive two independent loads or a single load in the full-bridge configuration. All drivers include output clamp/flyback diodes, input gain and level shifting, a voltage regulator for single-supply operation, and pulse-width modulated output-current control circuitry. Inputs are compatible with most TTL, DTL, LSTTL, and low-voltage CMOS or PMOS logic.

The peak output current and hysteresis for each source/sink pair is set independently. Output current, threshold voltage, and hysteresis are set by the user's selection of external resistors. At the specified output-current trip level, the source driver turns OFF. The internal clamp diode then allows current to flow without additional input from the power supply. When the lower current trip point is reached, the source driver turns back ON.

The UDN-2962B dual solenoid/motor driver is supplied in a 16-pin dual in-line plastic package with copper heat-sink contact tabs for medium package power dissipation levels (2.2W to >5W at +50°C). The lead configuration enables easy

Continued next page

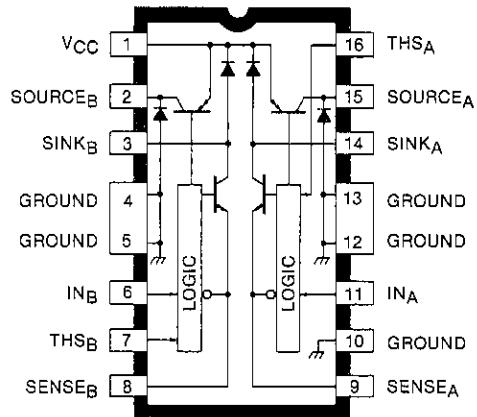

UDN-2962B

Dwg. No. D-1000

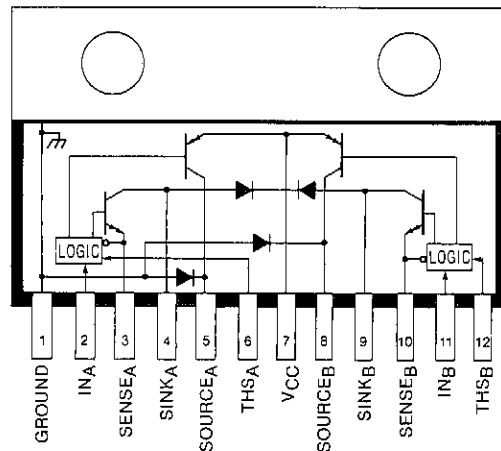

UDN-2962W

Dwg. No. D-1001

UDN-2962B AND UDN-2962W DUAL PWM SOLENOID/MOTOR DRIVERS

attachment of a heat sink while fitting a standard printed wiring board layout. The UDN-2962W, for higher package power dissipation requirements, is in a 12-pin single in-line power tab package. The tab is at ground potential and needs no insulation. With either package, for high-current or high-frequency applications, external heat sinking may be required.

ABSOLUTE MAXIMUM RATINGS at $T_{TAB} \leq +70^{\circ}\text{C}$

Supply Voltage, V_{CC}	45V
Peak Output Current, I_{OUT}	$\pm 4\text{A}$
Input Voltage Range, V_{IN}	-0.3V to $+7.0\text{V}$
Package Power Dissipation, P_D	See Graph
Operating Temperature Range, T_A	-20°C to $+85^{\circ}\text{C}$
Storage Temperature Range, T_S	-55°C to $+150^{\circ}\text{C}$

NOTE: Output current rating may be limited by duty cycle, ambient temperature, and heat sinking. Under any set of conditions, do not exceed the specified peak current and a junction temperature of $+150^{\circ}\text{C}$.

FUNCTIONAL BLOCK DIAGRAM (One of Two Drivers)

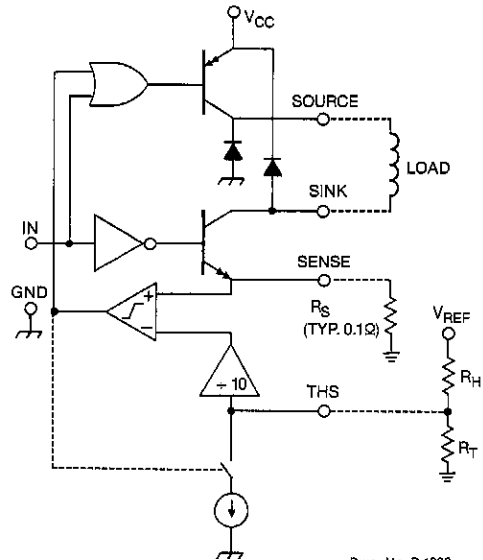

Dwg. No. D-1002

ALLOWABLE AVERAGE PACKAGE POWER DISSIPATION AS A FUNCTION OF TEMPERATURE

UDN-2962B

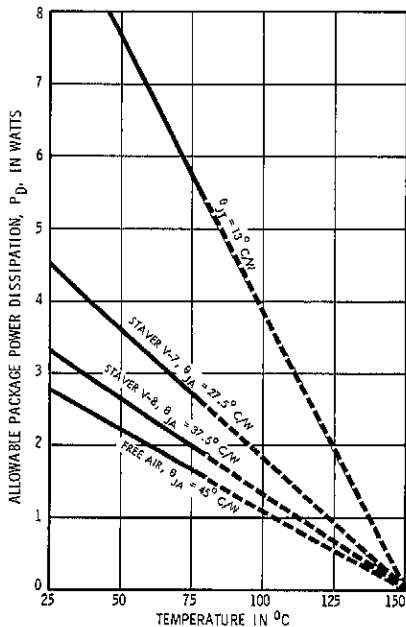

Dwg. No. A-11,793A

UDN-2962W

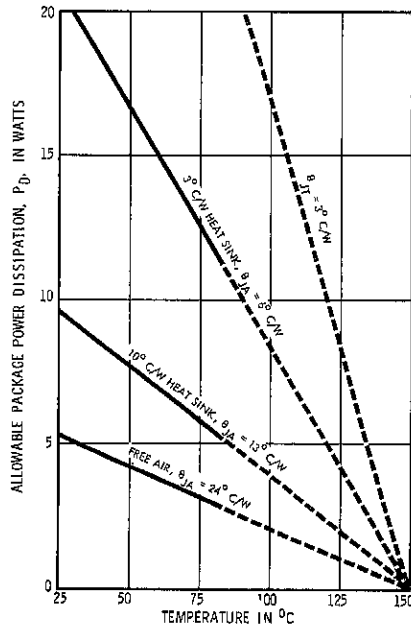

Dwg. No. A-11,794A

ELECTRICAL CHARACTERISTICS at $T_A = +25^\circ\text{C}$, $T_{\text{TAB}} \leq +70^\circ\text{C}$, $V_{\text{CC}} = 45\text{V}$, $V_{\text{SENSE}} = 0\text{V}$ (unless otherwise noted)

Characteristic	Symbol	Test Conditions	Limits			
			Min.	Typ.	Max.	Units
Supply Voltage Range	V_{CC}	Operating	20	—	45	V
Output Drivers						
Output Leakage Current	I_{CEX}	$V_{\text{IN}} = 2.4\text{V}$, $V_{\text{SOURCE}} = 0\text{V}$	—	< -1.0	-100	μA
		$V_{\text{IN}} = 2.4\text{V}$, $V_{\text{SINK}} = 45\text{V}$	—	< 1.0	100	μA
Output Saturation Voltage	$V_{\text{CE(SAT)}}$	Source Drivers, $I_{\text{LOAD}} = 3.0\text{A}$	—	2.1	2.3	V
		Source Drivers, $I_{\text{LOAD}} = 1.0\text{A}$	—	1.7	1.9	V
		Sink Drivers, $I_{\text{LOAD}} = 3.0\text{A}$	—	1.7	1.9	V
		Sink Drivers, $I_{\text{LOAD}} = 1.0\text{A}$	—	1.1	1.3	V
Output Sustaining Voltage	$V_{\text{CE(SUS)}}$	$I_{\text{OUT}} = \pm 3.0\text{A}$, $L = 3.5\text{mH}$	45	—	—	V
Output Current Regulation	ΔI_{OUT}	$V_{\text{THS}} = 0.6\text{V}$ to 1.0V , $L = 3.5\text{mH}$	—	—	± 25	%
		$V_{\text{THS}} = 1.0\text{V}$ to 2.0V , $L = 3.5\text{mH}$	—	—	± 10	%
		$V_{\text{THS}} = 2.0\text{V}$ to 5.0V , $L = 3.5\text{mH}$	—	—	± 5.0	%
Clamp Diode Forward Voltage	V_F	$I_F = 3.0\text{A}$	—	1.7	2.0	V
Output Rise Time	t_r	$I_{\text{LOAD}} = 3.0\text{A}$ 10% to 90%, Resistive Load	—	0.5	1.0	μs
Output Fall Time	t_f	$I_{\text{LOAD}} = 3.0\text{A}$, 90% to 10%, Resistive Load	—	0.5	1.0	μs
Control Logic						
Logic Input Voltage	$V_{\text{IN(1)}}$		2.0	—	—	V
	$V_{\text{IN(0)}}$		—	—	0.8	V
Logic Input Current	$I_{\text{IN(1)}}$	$V_{\text{IN}} = 2.4\text{V}$	—	1.0	10	μA
	$I_{\text{IN(0)}}$	$V_{\text{IN}} = 0.8\text{V}$	—	-20	-100	μA
	$I_{\text{THS(ON)}}$	$V_{\text{THS}} \geq 500\text{mV}$, $V_{\text{SENSE}} \leq V_{\text{THS}}/10.5$	—	-2.0	—	μA
	$I_{\text{THS(HYS)}}$	$V_{\text{SENSE}} \geq V_{\text{THS}}/9.5$, $V_{\text{THS}} = 0.6\text{V}$ to 5.0V	140	200	260	μA
$V_{\text{THS}}/V_{\text{SENSE}}$ Ratio	—	$V_{\text{THS}} = 2.0\text{V}$ to 5.0V	9.5	10	10.5	—
Supply Current (Total Device)	I_{CC}	$V_{\text{IN}} = 2.4\text{V}$, Outputs OFF	—	8.0	12	mA
		$V_{\text{IN}} = 0.8\text{V}$, Outputs Open	—	25	40	mA
Propagation Delay Time (Resistive Load)	t_{pd}	50% V_{IN} to 50% V_{OUT} , Turn OFF	—	—	2.5	μs
		50% V_{IN} to 50% V_{OUT} , Turn ON	—	—	3.0	μs
		100% V_{SENSE} to 50% V_{OUT}^*	—	—	2.0	μs

*Where $V_{\text{SENSE}} \geq V_{\text{THS}}/9.5$

NOTE: Negative current is defined as coming out of (sourcing) the specified device pin.

TRUTH TABLE

V_{IN}	V_{SENSE}	SOURCE DRIVER	SINK DRIVER
High	NA	Off	Off
Low	$< V_{\text{THS}}/10$	On	On
Low	$> V_{\text{THS}}/10$	Off	On

APPLICATIONS

The UDN-2962B/W driver is intended for use as a free-running, pulse-width modulated, motor or solenoid driver.

The source and sink drivers are both turned on by a low level at the input. When the load current reaches the trip point (set by external resistors), the comparator output goes high and the source driver is turned OFF. The internal clamp diode then allows current to flow without further input from the power supply. An internal constant current sink reduces the trip point (hysteresis) until the decaying current reaches the lower threshold, when the comparator output goes low and the source driver is again turned ON. Hysteresis percentage is a function of the external resistance R_H and is independent of the peak output load current

set by R_T . The chopping frequency is asynchronous and a function of the system and circuit parameters, including load inductance, supply voltage, hysteresis setting, and switching speed of the driver.

Maximum load current and hysteresis percentage are determined by the user:

$$R_H = 50 V_{REF} H$$

$$R_T = \frac{R_H (10 I_{MAX} R_S)}{V_{REF} - (10 I_{MAX} R_S)}$$

where $10 I_{MAX} R_S = V_{THS} = 0.6$ to $5.0V$
and $H =$ desired hysteresis in percent.

Graphical solutions for R_H and R_T , with $V_{REF} = 5V$ and $R_S = 0.1 \Omega$, follow.

TYPICAL WAVESHAPES

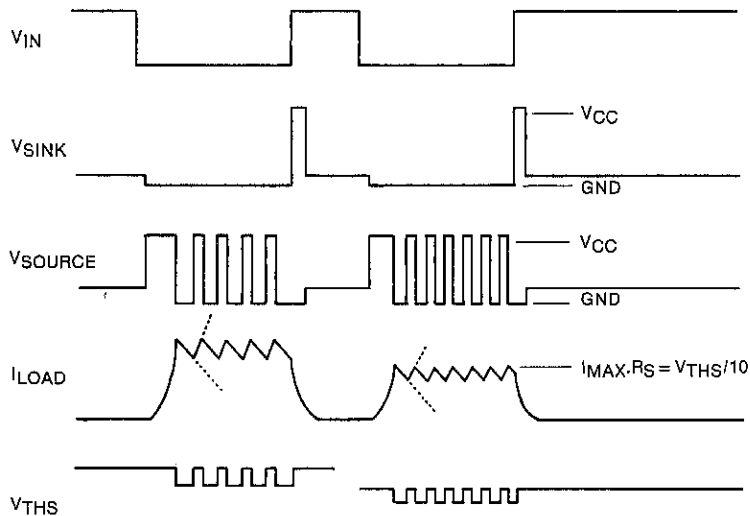

Dwg. No. D-1003

APPLICATIONS

RESISTOR R_H VALUE AS A FUNCTION OF HYSTERESIS

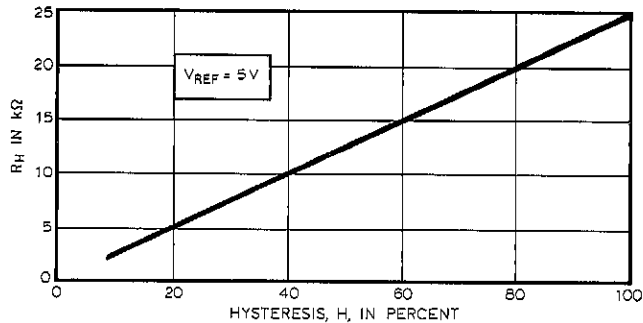

Dwg. No. A-12,417

RESISTOR R_T VALUE AS A FUNCTION OF PEAK LOAD CURRENT

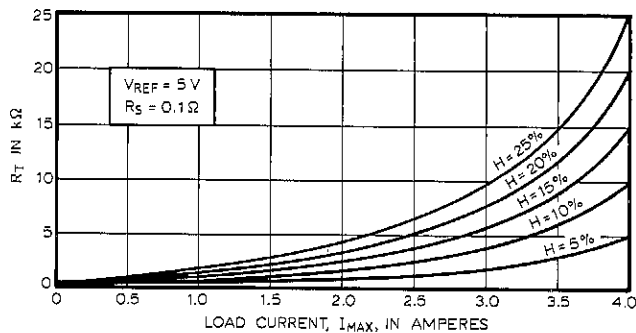

Dwg. No. A-12,416

For optimum operation of the UDN-2962B/W, the following design guidelines should be observed:

1. The V_{CC} supply should be decoupled with an electrolytic capacitor (10 μ F or greater). This capacitor should be placed as close to the driver as possible.
2. To minimize IR drops in the ground line, the printed wiring board should utilize a heavy ground plane; the driver should be soldered into the board, not used in a socket.
3. When using the UDN-2962B/W in an H-bridge configuration, a high-speed discrete diode must be used in series with each sink driver.

TYPICAL APPLICATION

BIPOLAR, PULSE-WIDTH MODULATED, STEPPER-MOTOR DRIVE

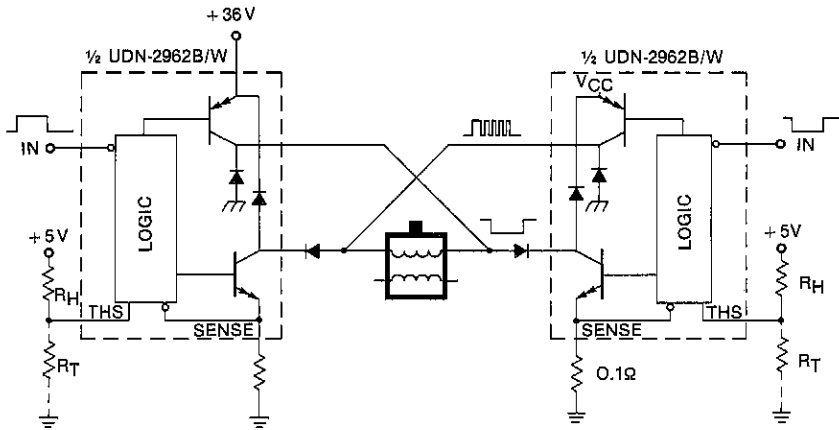

Dwg. No. D-1004

R_H AND R_T DETERMINE HYSTERESIS AND PEAK CURRENT

NOTE: Each of the drivers within the UDN-2962B/W includes an internal logic delay to prevent potentially destructive crossover currents within the driver during phase changes. However, never simultaneously enable both inputs in the full-bridge configurations: A destructive short-circuit to ground will result.

MOUNTING POWER TAB DEVICES

Power-tab packages are efficient thermal dissipators when properly utilized. In application, the following precautions should be taken:

1. Always fasten the tab to the heat sink before the leads are soldered to fixed terminals.
2. Strain relief must be provided if there is any probability of axial stress to the leads.
3. Thermal grease (Dow Corning 340 or equivalent) should always be used. Thermal compounds are better heat conductors than air but not a good substitute for flat mating surfaces.
4. The mounting surface should be flat to within 0.002 inch/inch (0.05 mm/mm).
5. Brute force mounting to poorly finished heat sinks can cause internal stresses which damage silicon chips and insulation parts. Mounting torque should be between 4 and 8 inch pounds (0.45 to 0.90 Nm.)
6. The mounting holes should be as clean as possible with no burrs or ridges.
7. Use appropriate hardware including a lock washer or torque washer.
8. If insulating bushings are used, they should be of dialyphthalate, fiberglass-filled polycarbonate, or fiberglass-filled nylon. Unfilled nylon should be avoided.

UDN-2965W-2 DUAL SOLENOID/MOTOR DRIVER

—Pulse-Width Modulated Current Control

FEATURES

- 5 A Peak Output
- 50 V Min. Output Sustaining Voltage
- TTL/PMOS/CMOS Compatible Inputs
- Low Input Current
- Internal Clamp Diodes
- Internal Thermal Shutdown
- High-Speed Chopper
- Plastic SIP With Heat-Sink Tab

DESIGNED TO DRIVE impact printer solenoids and stepper motors, the UDN-2965W-2 includes two independent driver pairs rated for continuous operation to ± 4 A. Each half-bridge driver includes diode transient protection, input gain and level shifting, a voltage regulator for single-supply operation, thermal protection, and pulse-width modulate (PWM) output-current control. Inputs are compatible with most TTL, DTL, LSTTL, and low-voltage CMOS or PMOS logic.

The PWM mode helps minimize power dissipation and maximize load efficiency. The peak output current and hysteresis for each half-bridge is set independently. Output current, threshold voltage, and hysteresis are set by the user's selection of external resistors. If desired, internal threshold and hysteresis defaults (400 mV and $\leq 10\%$) can be used. At the specified output-current trip level, the source driver turns OFF. The internal flyback diode then allows current to flow without additional input from the power supply. When the lower current trip point is reached, the source driver turns back ON.

For maximum power-handling capability, the driver is supplied in 12-pin single in-line power tab package. An external heat sink is required for proper

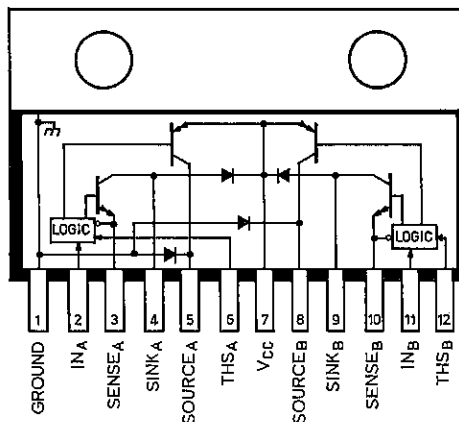

Dwg. No. A-12,413A

operation. The tab is at ground potential and needs no insulation.

Devices with sustaining voltage ratings of 60 V are presently in development as the UDN-2965W (no suffix). Similar dual 4 A solenoid drivers, for non-PWM applications, are available as Sprague Types UDN-2975W and UDN-2976W.

ABSOLUTE MAXIMUM RATINGS

at $T_{TAB} \leq +70^{\circ}\text{C}$

Supply Voltage, V_{CC}	50 V
Peak Output Current, I_{OUT}	± 5 A
Input Voltage Range, V_{IN}	-0.3 V to +7.0 V
Package Power Dissipation, P_D	See Graph
Operating Temperature Range, T_A	-20°C to +85°C
Storage Temperature Range, T_S	-55°C to +150°C

NOTE: Output current rating may be limited by duty cycle, ambient temperature, and heat sinking. Under any set of conditions, do not exceed the specified peak current and a junction temperature of +150°C.

4

FUNCTIONAL BLOCK DIAGRAM
 (ONE OF TWO DRIVERS)

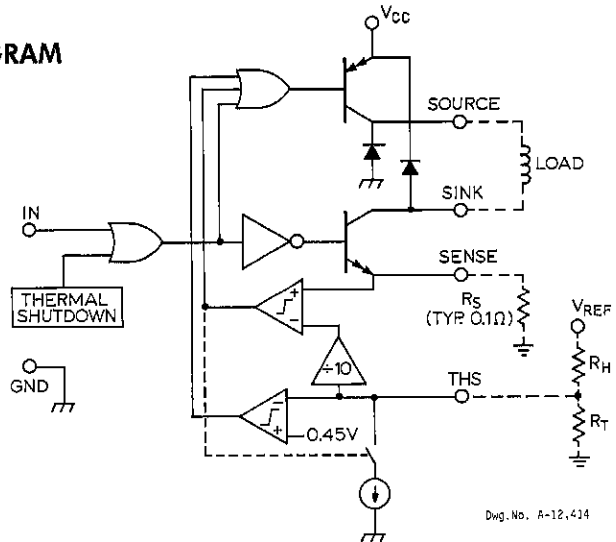

Dwg. No. A-12,414

ALLOWABLE AVERAGE PACKAGE POWER DISSIPATION
AS A FUNCTION OF TEMPERATURE

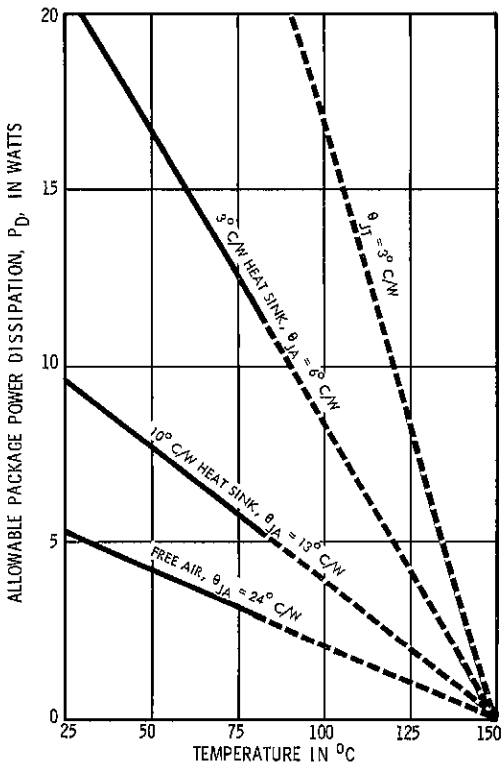

Dwg. No. A-11,794A

TRUTH TABLE

V_{IN}	V_{THS}	V_{SENSE}	Source Driver	Sink Driver	Hysteresis
High	NA	NA	Off	Off	NA
Low	<0.4 V	NA	Off	On	NA
Low	0.6 V to 4.0 V	< $V_{THS}/10$	On	On	Set by R_{TH}
Low	0.6 V to 4.0 V	> $V_{THS}/10$	Off	On	—
Low	>4.5 V	<0.4 V	On	On	5% to 10%
Low	>4.5 V	>0.4 V	Off	On	—

ELECTRICAL CHARACTERISTICS at $T_A = +25^\circ\text{C}$, $T_{\text{TAB}} \leq +70^\circ\text{C}$, $V_{\text{CC}} = 50\text{V}$, $V_{\text{SENSE}} = 0\text{V}$ (unless otherwise noted)

Characteristic	Symbol	Test Conditions	Limits			
			Min.	Typ.	Max.	Units
Supply Voltage Range	V_{CC}	Operating	20	—	50	V

Output Drivers

Output Leakage Current	I_{CEX}	$V_{\text{IN}} = 2.4\text{V}$, $V_{\text{SOURCE}} = 0\text{V}$	—	< -1.0	-100	μA
		$V_{\text{IN}} = 2.4\text{V}$, $V_{\text{SINK}} = 50\text{V}$	—	< 1.0	100	μA
Output Saturation Voltage	$V_{\text{CE(SAT)}}$	Source Drivers, $I_{\text{LOAD}} = 4.0\text{A}$	—	2.3	2.5	V
		Source Drivers, $I_{\text{LOAD}} = 1.0\text{A}$	—	1.7	1.8	V
		Sink Drivers, $I_{\text{LOAD}} = 4.0\text{A}$	—	2.1	2.3	V
		Sink Drivers, $I_{\text{LOAD}} = 4.0\text{A}$	—	1.0	1.2	V
Output Sustaining Voltage	$V_{\text{CE(SUS)}}$	$I_{\text{OUT}} = \pm 4.0\text{A}$, $L = 3.5\text{mH}$	50	—	—	V
Output Current Regulation	ΔI_{OUT}	$V_{\text{THS}} = 0.6\text{V}$ to 1.0V , $L = 3.5\text{mH}$	—	—	± 25	%
		$V_{\text{THS}} = 1.0\text{V}$ to 2.0V , $L = 3.5\text{mH}$	—	—	± 10	%
		$V_{\text{THS}} = 2.0\text{V}$ to 4.0V , $L = 3.5\text{mH}$	—	—	± 5.0	%
Clamp Diode Forward Voltage	V_F	$I_F = 4.0\text{A}$	—	1.8	2.0	V
Output Rise Time	t_r	$I_{\text{LOAD}} = 4.0\text{A}$, 10% to 90%, Resistive Load	—	0.5	1.0	μs
Output Fall Time	t_f	$I_{\text{LOAD}} = 4.0\text{A}$, 90% to 10%, Resistive Load	—	0.5	1.0	μs

Control Logic

Logic Input Voltage	$V_{\text{IN(1)}}$		2.0	—	—	V
	$V_{\text{IN(O)}}$		—	—	0.8	V
Logic Input Current	$I_{\text{IN(1)}}$	$V_{\text{IN}} = 2.4\text{V}$	—	1.0	10	μA
	$I_{\text{IN(O)}}$	$V_{\text{IN}} = 0.8\text{V}$	—	-20	-100	μA
	$I_{\text{THS(OFF)}}$	$V_{\text{THS}} \leq 400\text{mV}$	—	-60	—	μA
	$I_{\text{THS(ON)}}$	$V_{\text{THS}} \geq 500\text{mV}$, $V_{\text{SENSE}} \leq V_{\text{THS}}/10.5$	—	-2.0	—	μA
	$I_{\text{THS(HYS)}}$	$V_{\text{SENSE}} \geq V_{\text{THS}}/9.5$, $V_{\text{THS}} = 0.6\text{V}$ to 4.5V	140	200	260	μA
Output Disable Voltage	$V_{\text{THS(OFF)}}$		—	—	400	mV
$V_{\text{THS}}/V_{\text{SENSE}}$ Ratio	—	$V_{\text{THS}} = 2.0\text{V}$ to 4.0V	9.5	10	10.5	—
Default Sense Trip Voltage	V_{SENSE}	$V_{\text{THS}} = 4.5\text{V}$	380	400	420	mV
Default Hysteresis	H	$V_{\text{THS}} = 4.5\text{V}$	5.0	—	10	%
Supply Current (Total Device)	I_{CC}	$V_{\text{IN}} = 2.4\text{V}$, Outputs OFF	—	20	25	mA
		$V_{\text{IN}} = 0.8\text{V}$, Outputs Open	—	47	50	mA
Propagation Delay Time (Resistive Load)	t_{pd}	50% V_{IN} to 50% V_{OUT} , Turn OFF	—	—	2.5	μs
		50% V_{IN} to 50% V_{OUT} , Turn ON	—	—	3.0	μs
		100% V_{SENSE} to 50% V_{OUT} *	—	—	2.0	μs
Thermal Shutdown	T_J		—	175	—	$^\circ\text{C}$

*Where $V_{\text{SENSE}} \geq V_{\text{THS}}/9.5$

NOTE: Negative current is defined as coming out of (sourcing) the specified device pin.

NOTE: Each of the drivers within the UDN-2965W includes an internal logic delay to prevent potentially destructive crossover currents within the driver during phase changes. However, never simultaneously enable both inputs in the full-bridge configuration: A destructive short-circuit to ground will result.

4

APPLICATIONS

The UDN-2965W driver is intended for use as a free-running, pulse-width modulated, motor or solenoid driver.

The source and sink drivers are both turned ON by a low level at the input. When the load current reaches the trip point (set by external resistors or internal default), the comparator output goes high and the source driver is turned OFF. The internal flyback diode then allows current to flow without further input from the power supply. An internal constant current sink reduces the trip point (hysteresis) until the decaying current reaches the lower threshold, when the comparator output goes low and the source driver is again turned ON. Hysteresis percentage is a function of the external resistance R_H and is independent of the peak output load current set by R_T . The chopping frequency is asynchronous and a function of the system and circuit parameters, including load inductance, supply voltage, hysteresis setting, and switching speed of the driver.

Maximum load current and hysteresis percentage are determined by the user:

$$R_H = 50 V_{REF} H$$

$$R_T = \frac{R_H(10 I_{MAX} R_S)}{V_{REF} - (10 I_{MAX} R_S)}$$

where $10 I_{MAX} R_S = V_{THS} = 0.6$ to 4.0 V

and $H =$ desired hysteresis in percent.

Graphical solutions for R_H and R_T , with $V_{REF} = 5$ V and $R_S = 0.1 \Omega$, follow.

Pulling V_{THS} down to less than 0.4 V disables the source driver, turning the load OFF. With V_{THS} greater than 4.5 V, the hysteresis is fixed at (defaults to) between 5% and 10% and the peak load current is fixed at:

$$I_{MAX} = 0.4/R_S$$

TYPICAL WAVESHAPES

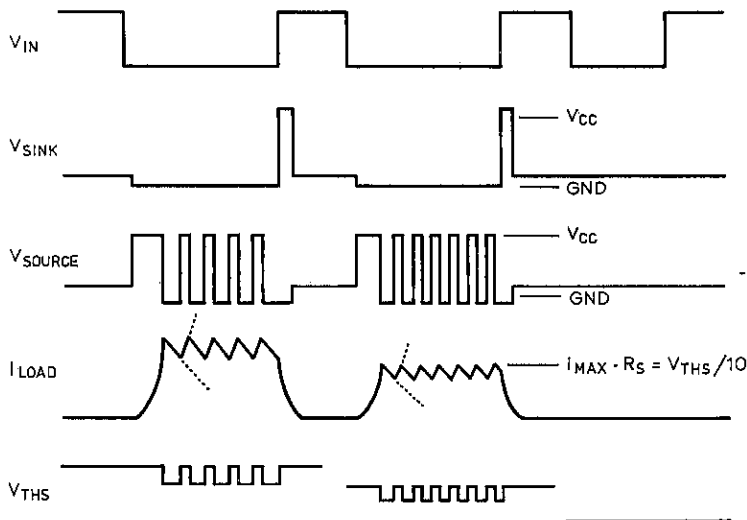

Dwg. No. A-12,415

RESISTOR R_H VALUE
 AS A FUNCTION OF HYSTERESIS

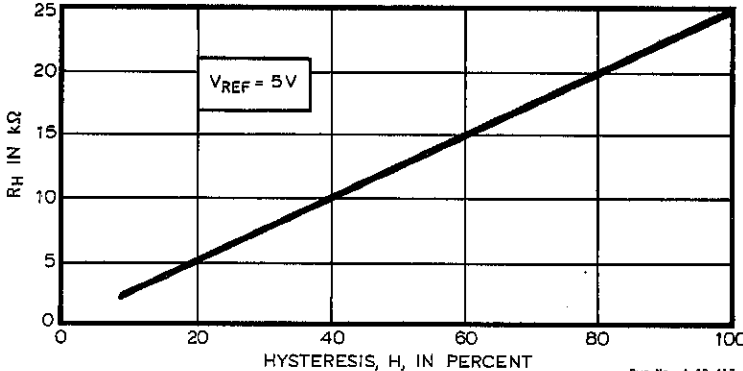

Dwg. No. A-12,417

PEAK LOAD CURRENT
 AS A FUNCTION OF
 RESISTOR R_T VALUE

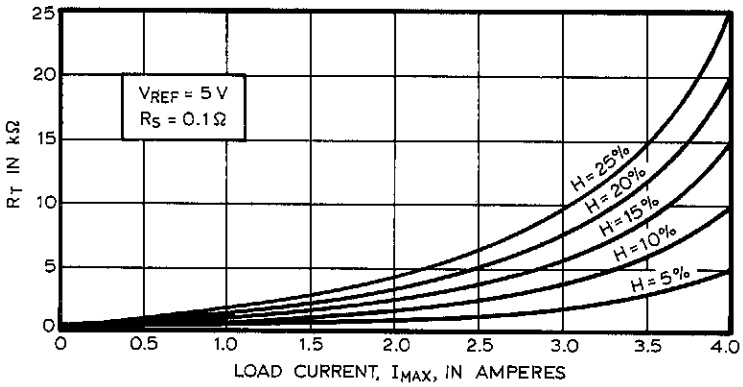

Dwg. No. A-12,416



BIPOLAR, PULSE-WIDTH MODULATED, STEPPER-MOTOR DRIVE

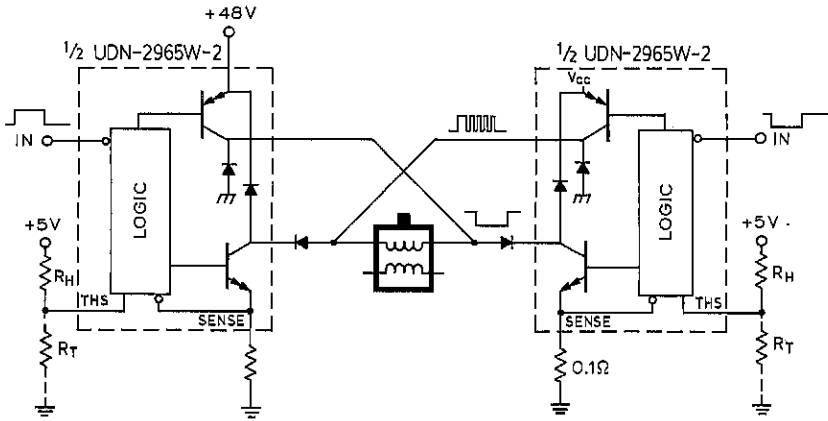

R_H AND R_T DETERMINE HYSTERESIS AND PEAK CURRENT

Dwg. No. B-1538

UDN-2975W AND UDN-2976W DUAL 4 A SOLENOID DRIVERS

FEATURES

- 5 A Peak Output
- TTL/PMOS/CMOS Compatible Inputs
- Low Input Current
- Output Voltage to 60 V
- Single-Ended or Split Supply
- Adjustable Short-Circuit Protection
- Internal Clamp Diodes
- Plastic SIP With Heat-Sink Tab

CURRENT CONTROL for operation of a pair of print solenoids is provided by both Type UDN-2975W and UDN-2976W. Each IC's dual driver sections operate directly from the printer control line. The two devices differ only in output-voltage ratings. They can be used at currents of up to 4 A.

Type UDN-2975W is rated at 50 V. Type UDN-2976W is rated at 60 V or ± 30 V. Inputs are compatible with most TTL, DTL, LSTTL, and 5 V to 15 V CMOS and PMOS logic.

Current is controlled by a current-sensing latch method that uses only one external sensing resistor for each driver. The load current is compared with the reference voltage and, at the level fixed by the system designer ($V_{REF}/10 = I_{LOAD} \times R_{SENSE}$), a latch is set, shutting OFF one of the output transistors. The internal flyback diode then maintains the flux without further input from the power supply, resulting in maximum efficiency. The latch is reset by pulling the input high.

For the maximum in power-handling capability, the integrated circuits are supplied in 12-pin single

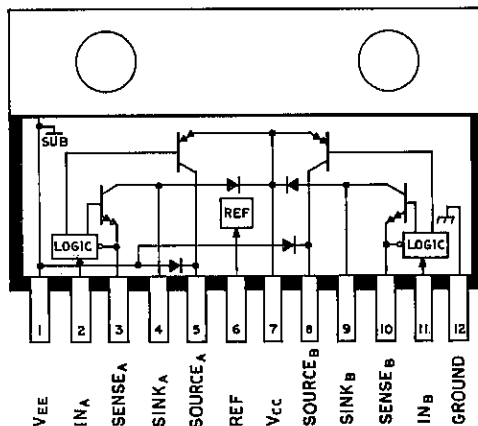

Dwg. No. A-12,105

in-line power tab packages. For proper operation, an external heat sink is required. The tab is at V_{EE} potential and must be insulated from ground when Type UDN-2976W is used with a split supply.

ABSOLUTE MAXIMUM RATINGS

at $T_{TAB} = +70^{\circ}\text{C}$

Supply Voltage, V_{CC} (Ref. V_{EE} , UDN-2975W)	50 V
(Ref. V_{EE} , UDN-2976W)	60 V
V_{EE} (Ref. GND, UDN-2975W)	0 V
(Ref. GND, UDN-2976W)	-30 V
Peak Output Current, I_{OU}	5 A
Input Voltage, V_{IN}	15 V
Reference Voltage, V_{REF}	5 V
Package Power Dissipation, P_D	See Graph
Operating Temperature Range, T_A	-20°C to +85°C
Storage Temperature Range, T_S	-55°C to +150°C

FUNCTIONAL BLOCK DIAGRAM
(ONE OF TWO DRIVERS)

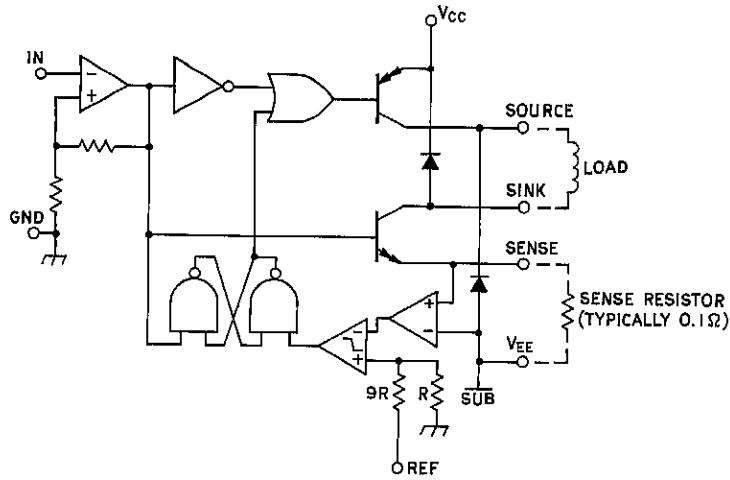

Dwg. No. A-12,106A

**ALLOWABLE AVERAGE PACKAGE POWER DISSIPATION
AS A FUNCTION OF TEMPERATURE**

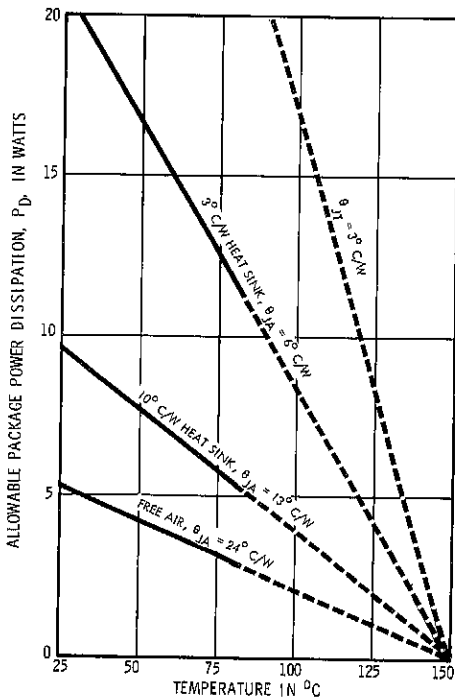

Dwg. No. A-11,794A

To maintain isolation between integrated circuit components and to provide for normal transistor operation, the substrate (pin 1) must be connected to the most negative point in the external circuit.

TRUTH TABLE

V_{IN}	V_{SENSE}	Source Driver	Sink Driver	Function
High	NA	Off	Off	Off
Low	$< V_{REF}/10$	On	On	On
Low	$> V_{REF}/10$	Off	On	Flyback

**UDN-2975W AND UDN-2976W
DUAL 4 A SOLENOID DRIVERS**

**ELECTRICAL CHARACTERISTICS at $T_A = +25^\circ\text{C}$, $T_{\text{TAB}} \leq +70^\circ\text{C}$, $V_{\text{CC}} = 45\text{ V}$ (UDN-2975W) or 55 V (UDN-2976W),
 $V_{\text{EE}} = V_{\text{SENSE}} = 0\text{ V}$ (unless otherwise noted)**

Characteristic	Symbol	Applicable Devices	Test Conditions	Limits		
				Min.	Max.	Units
Supply Voltage Range	V_{CC}	UDN-2975W	Operating	20	50	V
		UDN-2976W	Operating	20	60	V
Supply Current	I_{CC}	Both	Outputs Open	—	25	mA
	I_{EE}	Both	Outputs Open	—	-20	mA

Output Drivers

Output Leakage Current	I_{CEX}	UDN-2975W	$V_{\text{IN}} = 2.4\text{ V}$, $V_{\text{CC}} = 50\text{ V}$, $V_{\text{SOURCE}} = 0\text{ V}$	—	100	μA
			$V_{\text{IN}} = 2.4\text{ V}$, $V_{\text{SINK}} = V_{\text{CC}} = 50\text{ V}$	—	100	μA
		UDN-2976W	$V_{\text{IN}} = 2.4\text{ V}$, $V_{\text{CC}} = 60\text{ V}$, $V_{\text{SOURCE}} = 0\text{ V}$	—	100	μA
			$V_{\text{IN}} = 2.4\text{ V}$, $V_{\text{SINK}} = V_{\text{CC}} = 60\text{ V}$	—	100	μA
Output Saturation Voltage	$V_{\text{CE(SAT)}}$	Both	Source Drivers, $I_{\text{LOAD}} = 4\text{ A}$	—	3.5	V
			Sink Drivers, $I_{\text{LOAD}} = 4\text{ A}$	—	2.5	V
Output Sustaining Voltage (Source drivers only)	$V_{\text{CE(SUS)}}$	UDN-2975W	$I_{\text{LOAD}} = 4\text{ A}$, $L = 3.5\text{ mH}$	50	—	V
		UDN-2976W	$I_{\text{LOAD}} = 4\text{ A}$, $L = 3.5\text{ mH}$	60	—	V
Clamp Diode Forward Voltage	V_{F}	Both	$I_{\text{F}} = 4\text{ A}$	—	2.0	V
Output Rise Time	t_{r}	Both	$I_{\text{LOAD}} = 4\text{ A}$, 10% to 90%, Resistive Load	—	2.0	μs
Output Fall Time	t_{f}	Both	$I_{\text{LOAD}} = 4\text{ A}$, 90% to 10%, Resistive Load	—	2.0	μs

Control Logic

Logic Input Voltage	$V_{\text{IN(1)}}$	Both		2.0	—	V
	$V_{\text{IN(0)}}$	Both	See Notes	—	0.5	V
Logic Input Current	$I_{\text{IN(1)}}$	Both	$V_{\text{IN}} = 2.4\text{ V}$	—	20	μA
	$I_{\text{IN(0)}}$	Both	$V_{\text{IN}} = 0.4\text{ V}$	—	-20	μA
	$I_{\text{REF(1)}}$	Both	$V_{\text{REF}} = 5.0\text{ V}$	—	-20	μA
Reference/Sense Ratio	—	Both	$V_{\text{REF}} = 2.0\text{ to }5.0\text{ V}$	9.5	10.5	—
Propagation Delay Time	t_{pd}	Both	50% V_{IN} to 50% V_{OUT} , Resistive Load	—	3.0	μs
			100% V_{SENSE} to 50% V_{OUT}^* , Resistive Load	—	3.0	μs
Minimum Reset Pulse Width	t_{in}	Both		—	1.0	μs

*Where $V_{\text{SENSE}} = V_{\text{REF}}/10.5$

NOTES: Negative current is defined as coming out of (sourcing) the specific device pin.
For improved noise immunity, hysteresis insures $V_{\text{MIN(0)}}$ of 0.8 V max. after V_{IN} is 0.5 V or less.

UDN-2998W DUAL FULL-BRIDGE MOTOR DRIVER

FEATURES

- ± 3 A Peak Output Current
- Output Voltage to 50 V
- Integral Output Suppression Diodes
- Output Current Sensing
- TTL/CMOS Compatible Inputs
- Internal Thermal Shutdown Circuitry
- Crossover-Current Protected

As an interface between low-level logic and solenoids, brushless dc motors, or stepper motors, the UDN-2998W dual full-bridge driver will operate inductive loads up to 50 V with continuous output currents of up to 2 A per bridge or peak (start-up) currents to 3 A. The control inputs are compatible with TTL, DTL, and 5 V CMOS logic. Except for a common supply voltage and thermal shutdown, the two drivers in each package are completely independent.

For external PWM control, an OUTPUT ENABLE for each bridge circuit is provided and the sink driver emitters are pinned out for connection to external current-sensing resistors. The chopper drive mode is characterized by low power dissipation levels and maximum efficiency. A PHASE input to each bridge determines load-current direction.

Extensive circuit protection is provided on-chip. Both ground-clamp and flyback diodes for each bridge are provided. A thermal shutdown circuit disables the load drive if chip temperature rating (package power dissipation) is exceeded. Internally-generated delays provide crossover-current protection.

The UDN-2998W is packaged in a 12-pin single in-line power tab package for high power capabilities. Driving either of the bridges at the full 2 A dc rating

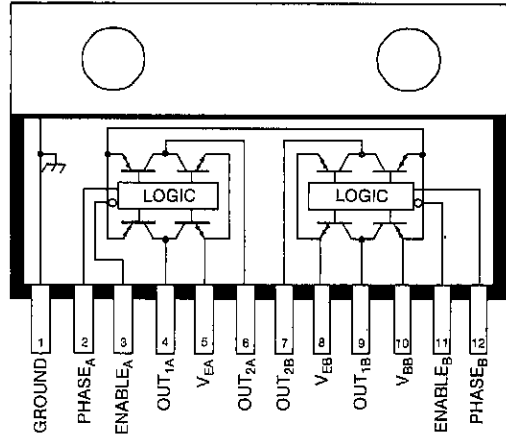

Dwg. No. W-10

4

requires the use of an external heat-sink. The tab is a ground potential and needs no insulation.

A similar dual full-bridge driver for use with continuous load currents to ± 500 mA is the UDN-2993B.

ABSOLUTE MAXIMUM RATINGS at $T_{TAB} \leq +70^\circ\text{C}$

Supply Voltage, V_{BB}	50 V
Output Current, I_{OUT} (DC)	± 2 A
(Peak)	± 3 A
Sink Driver Emitter Voltage, V_E	1.5 V
Logic Input Voltage Range,	
V_{PHASE} or V_{ENABLE}	-0.3 V to 15 V
Package Power Dissipation, P_D	See Graph
Operating Temperature Range, T_A	-20°C to $+85^\circ\text{C}$
Storage Temperature Range, T_S	-55°C to $+150^\circ\text{C}$

NOTE: Output current rating may be limited by chopping frequency, ambient temperature, air flow, or heat sinking. Under any set of conditions, do not exceed the specified current rating or a junction temperature of $+150^\circ\text{C}$.

FUNCTIONAL BLOCK DIAGRAM
 (ONE OF TWO DRIVERS)

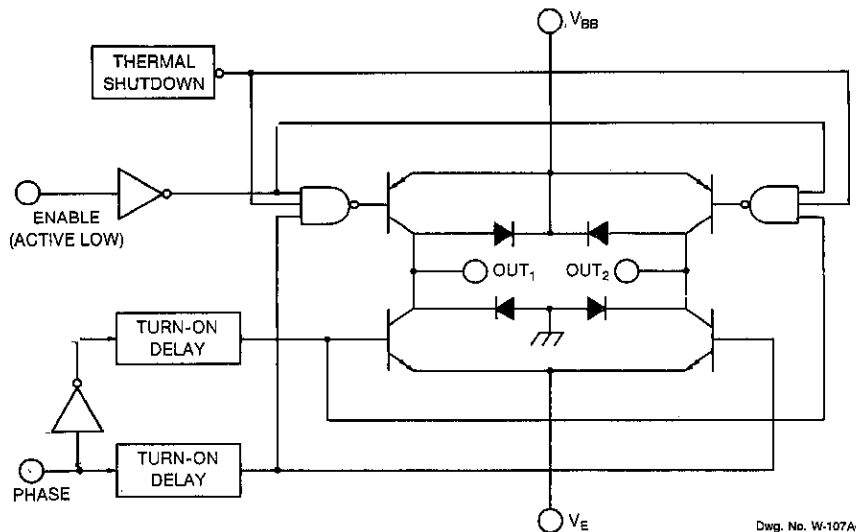

ALLOWABLE AVERAGE PACKAGE POWER DISSIPATION
 AS A FUNCTION OF TEMPERATURE

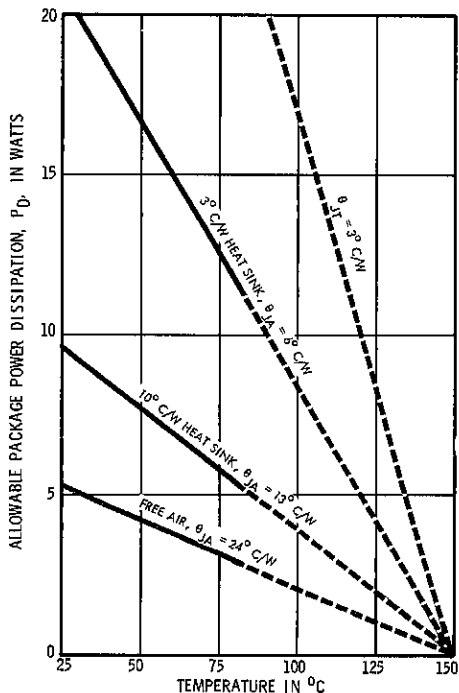

To maintain isolation between integrated circuit components and to provide for normal transistor operation, the ground tab must be connected to the most negative point in the external circuit.

TRUTH TABLE

Enable Input	Phase Input	Output 1	Output 2
Low	High	High	Low
Low	Low	Low	High
High	High	Open	Low
High	Low	Low	Open

ELECTRICAL CHARACTERISTICS at $T_A = +25^\circ\text{C}$, $T_{TAB} \leq +70^\circ\text{C}$, $V_{BB} = 50\text{V}$

Characteristic	Symbol	Test Conditions	Limits			
			Min.	Typ.	Max.	Units
Output Drivers						
Operating Voltage Range	V_{BB}		10	—	50	V
Output Leakage Current	I_{CEX}	$V_{OUT} = 50\text{V}$, $V_{ENABLE} = 2.0\text{V}$, Note 2	—	<5.0	50	μA
		$V_{OUT} = 0$, $V_{ENABLE} = 2.0\text{V}$, Note 2	—	<-5.0	-50	μA
Output Saturation Voltage	$V_{CE(SAT)}$	$I_{OUT} = 1\text{A}$, Sink Driver	—	1.2	1.4	V
		$I_{OUT} = 2\text{A}$, Sink Driver	—	1.7	1.9	V
		$I_{OUT} = -1\text{A}$, Source Driver	—	1.7	1.9	V
		$I_{OUT} = -2\text{A}$, Source Driver	—	2.0	2.2	V
Output Sustaining Voltage	$V_{CE(SUS)}$	$I_{OUT} = \pm 2\text{A}$, $L = 3.5\text{mH}$, Note 2	50	—	—	V
Source Driver Rise Time	t_r	$I_{OUT} = -2\text{A}$	—	500	—	ns
Source Driver Fall Time	t_f	$I_{OUT} = -2\text{A}$	—	750	—	ns
Deadtime	t_d	$I_{OUT} = \pm 2\text{A}$	—	2.5	—	μs
Clamp Diode Leakage Current	I_R	$V_R = 50\text{V}$	—	<5.0	50	μA
Clamp Diode Forward Voltage	V_F	$I_F = 2\text{A}$	—	1.5	2.0	V
Supply Current	I_{BB}	$V_{ENABLE(1)} = V_{ENABLE(2)} = 0.8\text{V}$	—	25	30	mA
		$V_{ENABLE(1)} = V_{ENABLE(2)} = 2.0\text{V}$	—	20	25	mA

Control Logic (PHASE or ENABLE)

Logic Input Voltage	$V_{IN(0)}$		0.8	—	—	V
	$V_{IN(1)}$		—	—	2.0	V
Logic Input Current	$I_{IN(0)}$	V_{PHASE} OR $V_{ENABLE} = 0.8\text{V}$	—	-5.0	-25	μA
	$I_{IN(1)}$	V_{PHASE} OR $V_{ENABLE} = 2.0\text{V}$	—	<1.0	10	μA
Turn-On Delay Time	t_{pd0}	ENABLE Input to Source Drivers	—	0.4	1.0	μs
Turn-Off Delay Time	t_{pd1}	ENABLE Input to Source Drivers	—	2.0	4.0	μs

NOTES:

1. Each driver is tested separately.
2. Test is performed with $V_{PHASE} = 0.8\text{V}$ and then repeated for $V_{PHASE} = 2.0\text{V}$.
3. Negative current is defined as coming out of (sourcing) the specified device pin.

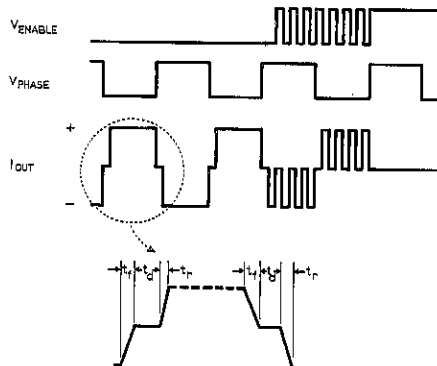

Dwg. No. A-14,272

TYPICAL APPLICATION
2-PHASE BIPOLAR STEPPER MOTOR DRIVE
 (Chopper Mode)

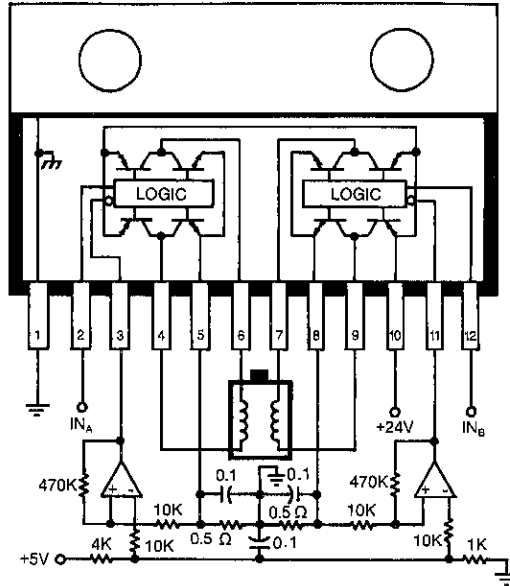

Dwg. No. W-108

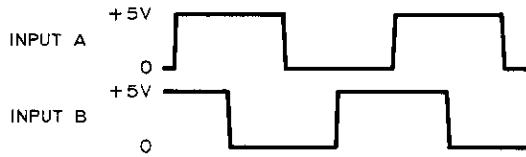

Dwg. No. A-12,454

ULN-3751Z POWER OPERATIONAL AMPLIFIER

FEATURES

- $\pm 3\text{ V}$ to $\pm 13\text{ V}$ Operation
- High Output Swing
- Peak Output Current to $\pm 3.5\text{ A}$
- Low Input Offset
- 90 dB Typical Open-Loop Gain
- Internal Thermal Shutdown
- High Common-Mode Input Range
- Unity Gain Stable
- Pin Compatible with L165, L465, SG1173

As a combination general-purpose operational amplifier and power booster, the ULN-3751Z integrated circuit simplifies circuit design, reduces component count, and enhances system reliability.

The power op amp features high-impedance differential inputs, a unity-gain stable amplifier that needs no external compensation, and a high-current power output. Typical applications include use as a voice-coil motor driver, linear servo amplifier, power oscillator, bipolar voltage regulator, and audio power driver.

The ULN-3751Z is for applications demanding up to $\pm 3.5\text{ A}$ of output current. It is furnished in a modified 5-lead JEDEC-style TO-220 plastic package. Lead forming for vertical or horizontal mounting is available (ULN-3751ZV or ULN-3715ZH). The heat sink tab is at substrate potential and must be insulated from ground when the device is used with a split supply.

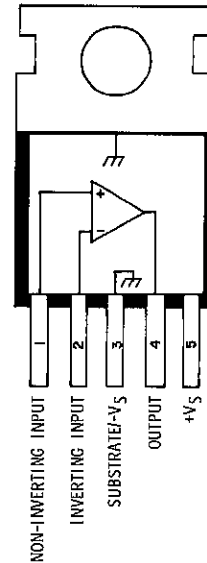

Dwg. No. A-12,364

This power op amp operates over a recommended supply voltage range of $\pm 3\text{ V}$ to $\pm 13\text{ V}$. Dual power op amps are available as the ULN-3755B (16-pin DIP) and the high-power ULN-3755W (12-pin SIP). Both of those devices include output current sensing and a voltage boost connection to maximum output voltage swing to $\pm 20\text{ V}$ supplies at up to $\pm 3.5\text{ A}$ peak output current.

4

ABSOLUTE MAXIMUM RATINGS
at $T_A = +25^\circ\text{C}$

Supply Voltage Differential ($+V_S$ to $-V_S$)	28 V
Peak Output Current, I_{OUT}	± 3.5 A
Input Voltage Range, V_{IN}	$+V_S$ to $-V_S - 0.3$ V
Package Power Dissipation, P_D	See Graph
Operating Temperature Range, T_A	0°C to $+70^\circ\text{C}$
Storage Temperature Range, T_S	-40°C to $+150^\circ\text{C}$

ALLOWABLE POWER DISSIPATION
AS A FUNCTION OF AMBIENT TEMPERATURE

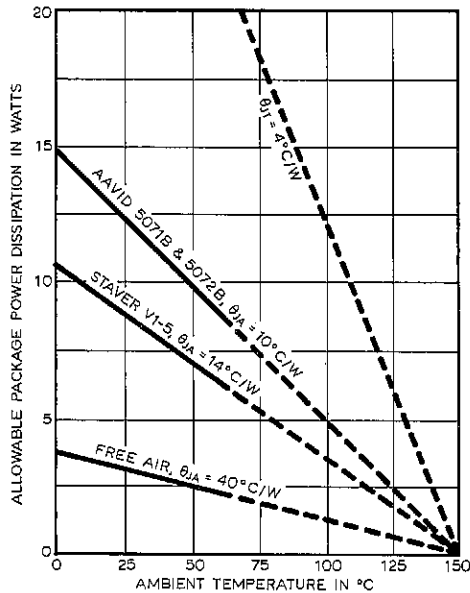

Dwg. No. A-14,249

ELECTRICAL CHARACTERISTICS at $T_A = +25^\circ\text{C}$, $T_{\text{TAB}} \leq +70^\circ\text{C}$, $V_S = \pm 6.0\text{ V}$ (unless otherwise noted)

Characteristic	Test Conditions	Limits			Unit
		Min.	Typ.	Max.	
Functional Supply Voltage Range	$+V_S$ to $-V_S$	6.0	—	26	V
Quiescent Supply Current		—	40	60	mA
Input Bias Current	$V_{\text{IN}} = 0$, $I_{\text{OUT}} = 0$	—	-60	-1000	nA
Input Offset Voltage	$V_{\text{IN}} = 0$, $I_{\text{OUT}} = 0$	—	± 2.0	± 10	mV
Input Offset Current	$V_{\text{IN}} = 0$, $I_{\text{OUT}} = 0$	—	10	100	nA
Input Noise Voltage†	BW = 40 Hz to 15 kHz	—	4.0	—	μV
Input Noise Current†	BW = 40 Hz to 15 kHz	—	60	—	pA
Crossover Distortion†	$P_{\text{OUT}} = 50\text{ mW}$, $R_L = 4\ \Omega$	—	<0.05	—	%
Common Mode Rejection	$\Delta V_{\text{CM}} = 2\text{ V}$	60	85	—	dB
Input Common Mode Range†	Positive	—	$+V_S - 2\text{ V}$	—	V
	Negative	—	$-V_S - 0.3\text{ V}$	—	V
Open-Loop Voltage Gain	$f = 0$	80	90	—	dB
Slew Rate	$V_{\text{IN}} = V_{\text{OUT}} = 6\text{ Vpp}$, $R_L = \infty$	1.0	2.3	—	V/ μs
Gain-Bandwidth Product†	$A_v = 40\text{ dB}$	—	3.5	—	MHz
Output Voltage Swing	$I_{\text{OUT}} = 1.0\text{ A}$	4.5	4.7	—	V
	$I_{\text{OUT}} = -1\text{ A}$	-4.5	-4.7	—	V
Supply Voltage Rejection	$+V_S$, $\Delta V = 1\text{ V}$	60	85	—	dB
	$-V_S$, $\Delta V = 1\text{ V}$	60	80	—	dB
Thermal Shutdown Temp.†		—	160	—	$^\circ\text{C}$

*This parameter is tested to a lot sample plan only.

†Typical values given for circuit design information only.

4

TYPICAL APPLICATIONS

**WIEN BRIDGE
OSCILLATOR/MOTOR DRIVER**

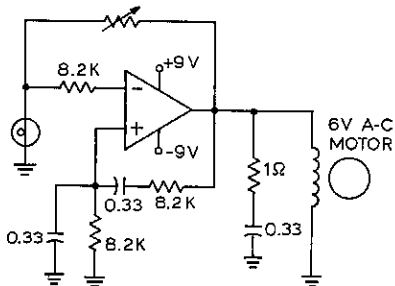

Dwg. No. A-12,375B

**VIDEO MONITOR
VERTICAL DEFLECTION MAP**

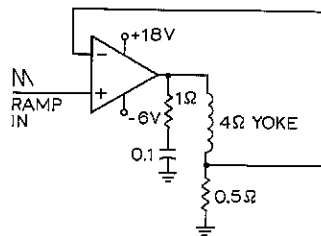

Dwg. No. A-12,375A

TYPICAL APPLICATIONS

UNITY GAIN VOLTAGE FOLLOWER

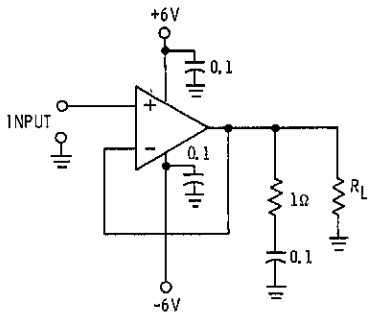

Dwg. No. A-12,551

NON-INVERTING POWER AMPLIFIER

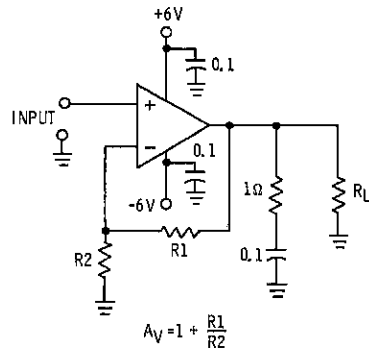

$$A_V = 1 + \frac{R_1}{R_2}$$

CAPACITANCE VALUES IN μF.

Dwg. No. A-12,552

LINEAR VOLTAGE REGULATOR

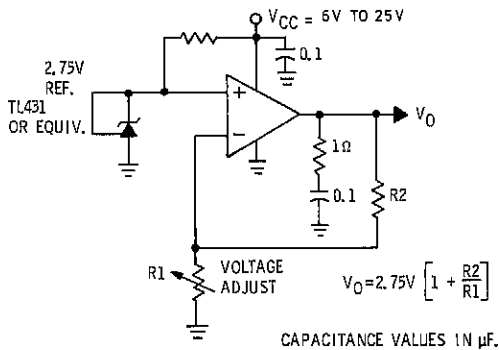

$$V_O = 2.75V \left[1 + \frac{R_2}{R_1} \right]$$

CAPACITANCE VALUES IN μF.

Dwg. No. A-12,553A

HIGH-POWER LINEAR REGULATOR

(Short-Circuit Protected)

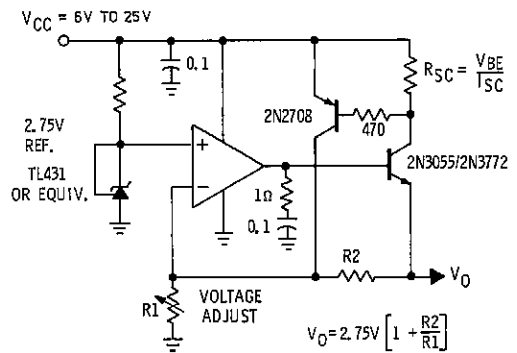

$$V_O = 2.75V \left[1 + \frac{R_2}{R_1} \right]$$

CAPACITANCE VALUES IN μF.

Dwg. No. A-12,554B

TYPICAL APPLICATIONS

SINGLE-ENDED POSITION SERVO WITH SENSE POTENTIOMETER

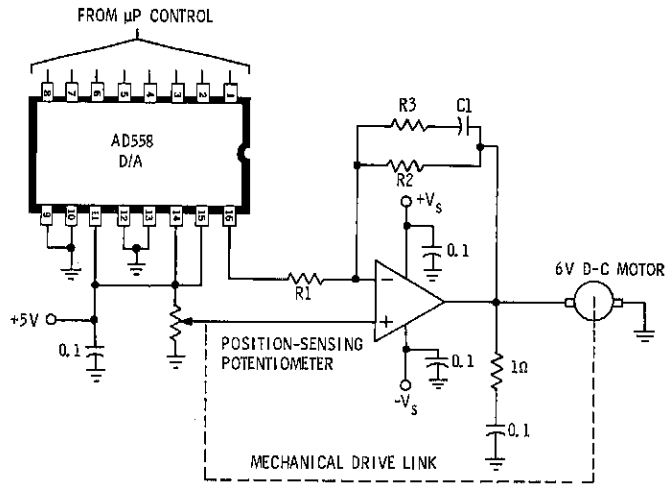

R1, R2 DEFINE D-C GAIN.
R3, C1 PICKED TO PROVIDE LOOP COMPENSATION.
CAPACITANCE VALUES IN μF .

Dwg. No. A-12,556

SIMPLIFIED SERVO APPLICATION WITH CONTROL TRANSFORMERS

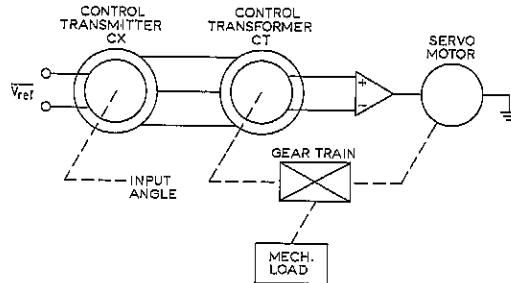

Dwg. No. A-14,250

4

ULN-3753B AND ULN-3753W

DUAL POWER OPERATIONAL AMPLIFIERS

FEATURES

- Operating Supply Range $\pm 3\text{V}$ to $\pm 20\text{V}$
- Output Current to $\pm 3.5\text{A}$ Peak
- Output-Current Limiting
- Output-Current Sensing
- High Output-Voltage Swing
- Low Crossover Distortion
- Low Input Offset Voltage
- Externally Compensated
- High Open-Loop Gain
- Output Protection Diodes
- Thermal Shutdown Protection
- Excellent Supply and Common-Mode Rejection
- Single or Dual In-Line Power Packages

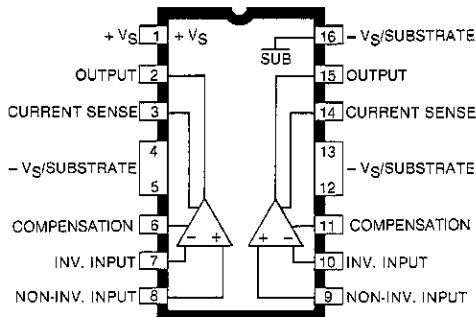

Dwg. No. A-13, 636

ULN-3753B

APPLICATIONS

- Dual Half-Bridge and Full-Bridge Motor Drivers
 - Linear Servo Motors
 - Voice Coil Motors
 - AC and DC Motors
 - Microstepping Applications
- Power Transconducting Amplifier
- Audio Power Amplifier, Stereo or BTL
- Power Oscillator/Amplifier
- Dual Bipolar Voltage Regulator

High-current linear servo loads, such as voice coil motors used in disc-drive applications, are ideal applications for the ULN-3753B and ULN-3753W dual high-power operational amplifiers. Their building block design concept also makes them ideal for a wide variety of other motor drive applications, audio power amplifiers, power oscillators, and linear voltage regulators. External compensation permits user adjustment of bandwidth and phase margin at any gain level.

The ULN-3753B is furnished in a 16-pin dual in-line package with copper heat-sink contact tabs. For higher power requirements, the ULN-3753W is supplied in a 12-pin single in-line power tab package.

The inputs are designed to allow a wide common mode range from the negative supply, (or ground in

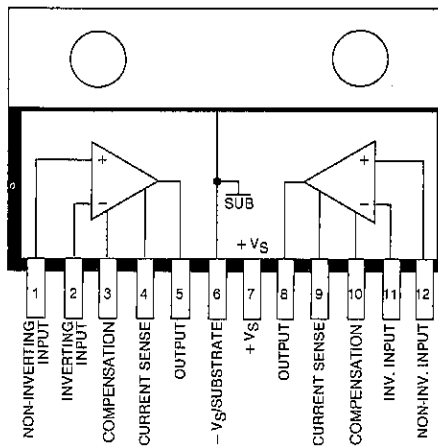

Dwg. No. A-13, 632

ULN-3753W

single supply applications) to within approximately 2V of the positive supply. Common-mode and power supply rejection are in excess of 60 dB. The amplifiers' wide output swing is complemented by current sensing, which is referenced to the negative supply and allows for feedback as required to produce a transconductance characteristic.

**ULN-3753B AND ULN-3753W
DUAL POWER OPERATIONAL AMPLIFIERS**

The ULN-3753B (batwing DIP) can typically dissipate 6W at a tab temperature of 70°C. The lead configuration enables easy attachment of a heat sink while fitting a standard socket or printed wiring board layout. The ULN-3753W (SIP) can safely dissipate significantly higher power levels with appropriate heat sinking. With either package configuration, the heat sink is at the negative supply, or at ground in a single-ended application.

ABSOLUTE MAXIMUM RATINGS

Supply Voltage Differential (+V _S to -V _S)	40 V
Peak Supply Voltage (50 ms)	45 V
Continuous Output Current, I _{OUT} (V _S = ±15 V)	±	2.0 A
(V _S = ±6 V)	±	2.5 A
Peak Output Current, I _{OUT} (50 ms)	±3.5 A
Package Power Dissipation, P _D	See Graphs
Operating Temperature Range, T _A	-20°C to +85°C
Storage Temperature Range, T _S	-55°C to +125°C

**ALLOWABLE AVERAGE PACKAGE POWER DISSIPATION
AS A FUNCTION OF TEMPERATURE**

ULN-3753B

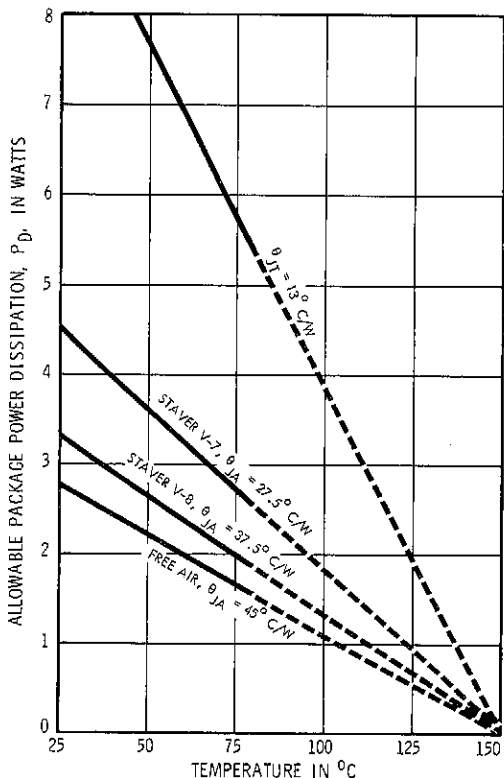

Dwg. No. A-11. 793B

ULN-3753W

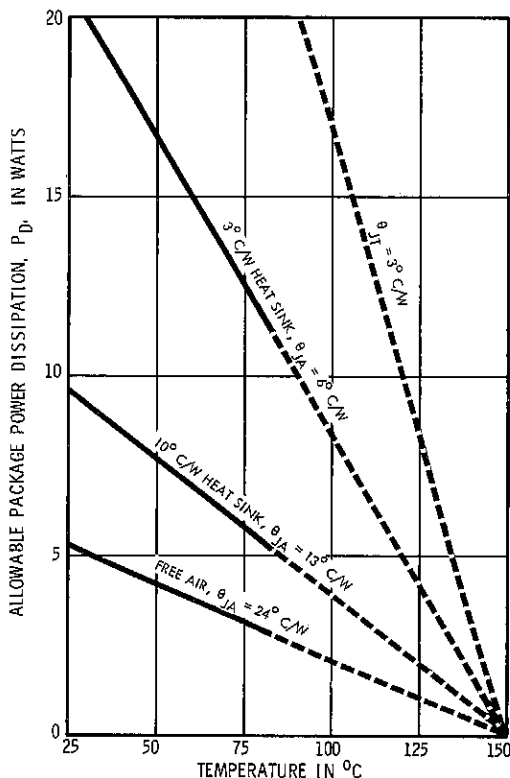

Dwg. No. A-11. 794A

ULN-3753B AND ULN-3753W
DUAL POWER OPERATIONAL AMPLIFIERS

ELECTRICAL CHARACTERISTICS at $T_A = +25^\circ\text{C}$, $T_{TAB} \leq +70^\circ\text{C}$, $V_S = \pm 6\text{V}$, $C_C = 0$, each amplifier tested separately (unless otherwise specified)

Characteristic	Test Conditions	Limits			
		Min.	Typ.	Max.	Units
Functional Supply Voltage Range	$+V_S$ to $-V_S$	6.0	—	40	V
Quiescent Supply Current		—	90	150	mA
Input Bias Current	$V_{OUT} = 0$	—	-80	-1000	nA
Input Offset Voltage	$V_{OUT} = 0, I_{OUT} = 0$	—	± 1.0	+10	mV
Input Offset Volt. TC^\dagger	Over Op. Temp. Range	—	-15	—	$\mu\text{V}/^\circ\text{C}$
Input Offset Current	$V_{OUT} = 0, I_{OUT} = 0$	—	10	100	nA
Input Noise Voltage [†]	BW = 40 Hz to 15 kHz	—	4.0	—	μV
Input Noise Current [†]	BW = 40 Hz to 15 kHz	—	60	—	pA
Crossover Distortion [†]	$P_{OUT} = 50\text{mW}$, $R_L = 4\Omega$	—	0.2	—	%
Common Mode Rejection	$V_{CM} = 3\text{V}$	60	85	—	dB
Input Common Mode Range*	$V_S = +6\text{V}$	-6.3	—	+4.0	V
	$V_S = +15\text{V}$	-15.3	—	+13	V
Open Loop Voltage Gain	$f = 0$	80	100	—	dB
Slew Rate	$V_{IN} = V_{OUT} = 6\text{Vpp}$	5.0	10	—	$\text{V}/\mu\text{s}$
Gain-Bandwidth Product [†]	$A_V = 40\text{dB}$	—	3.0	—	MHz
Channel Separation [†]	$I_{OUT} = 100\text{mA}$, $f = 1\text{kHz}$	—	60	—	dB
Output Voltage Swing	$I_{OUT} = 1\text{A}$	9.0	9.5	—	Vpp
Supply Voltage Rejection	$+V_S, \Delta V = 1\text{V}$	60	85	—	dB
	$-V_S, \Delta V = 1\text{V}$	60	80	—	dB
Thermal Resistance, Θ_{JT}^*	ULN-3753B	—	—	15	$^\circ\text{C}/\text{W}$
	ULN-3753W	—	—	3.0	$^\circ\text{C}/\text{W}$
Thermal Shutdown Temp. [†]		—	165	—	$^\circ\text{C}$

*This parameter is tested to a lot sample plan only.

[†]Typical values given for circuit design information only.

NON-INVERTING AMPLIFIER

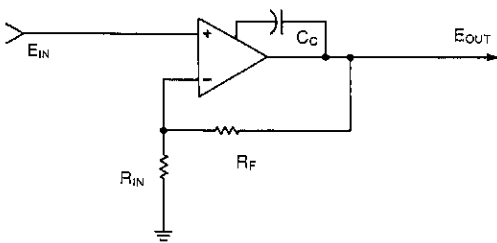

$$\frac{E_{OUT}}{E_{IN}} = 1 + \frac{R_F}{R_{IN}}$$

IF $R_F = 0$ OR $R_{IN} = \infty$, $E_{OUT} = E_{IN}$

Dwg. No. W-155

INVERTING AMPLIFIER

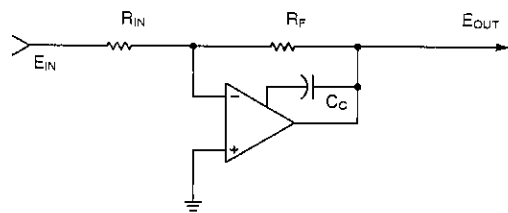

$$\frac{E_{OUT}}{E_{IN}} = -\frac{R_F}{R_{IN}}$$

Dwg. No. W-156

TYPICAL CHARACTERISTICS

OPEN-LOOP VOLTAGE GAIN
AS A FUNCTION OF TEMPERATURE

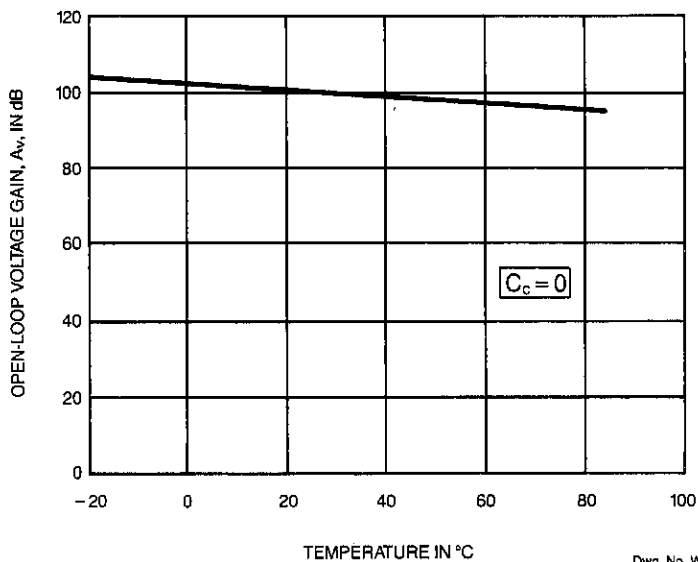

Dwg. No. W-158

4

SUPPLY CURRENT AS A FUNCTION
OF SUPPLY VOLTAGE DIFFERENTIAL

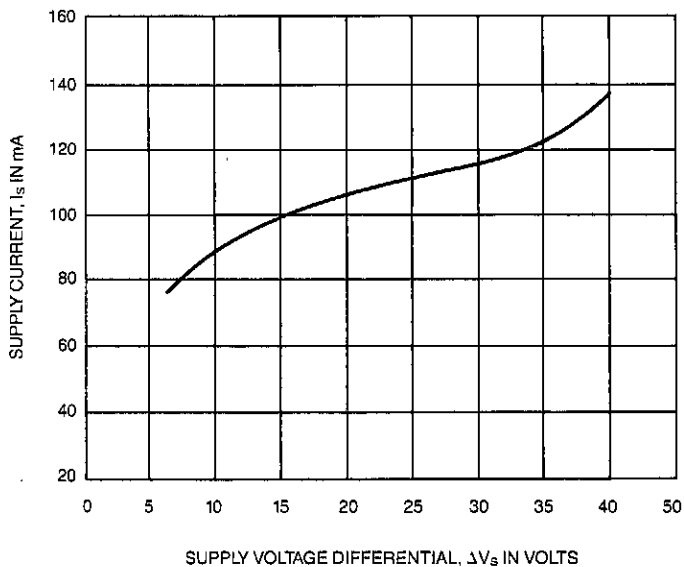

Dwg. No. W-161

TYPICAL CHARACTERISTICS

INPUT BIAS CURRENT
AS A FUNCTION OF TEMPERATURE

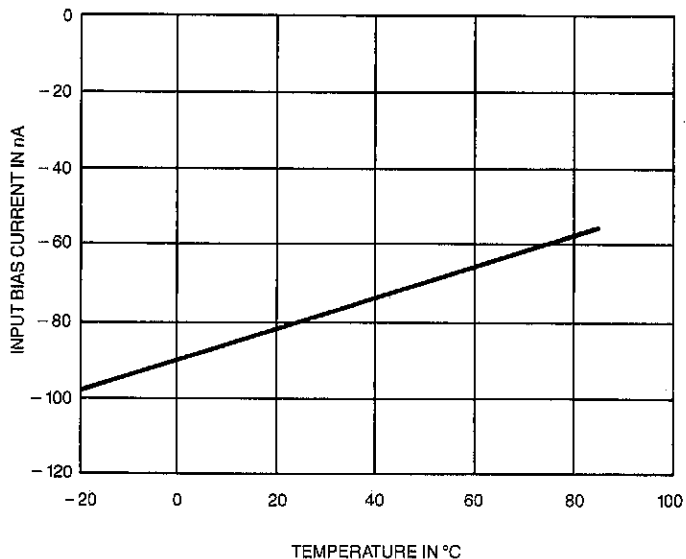

Dwg. No. W-159

INPUT OFFSET VOLTAGE
AS A FUNCTION OF TEMPERATURE

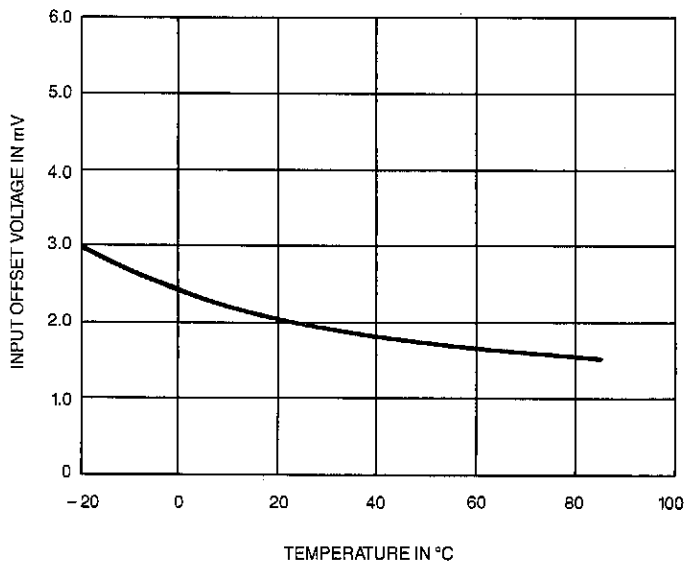

Dwg. No. W-160

APPLICATIONS

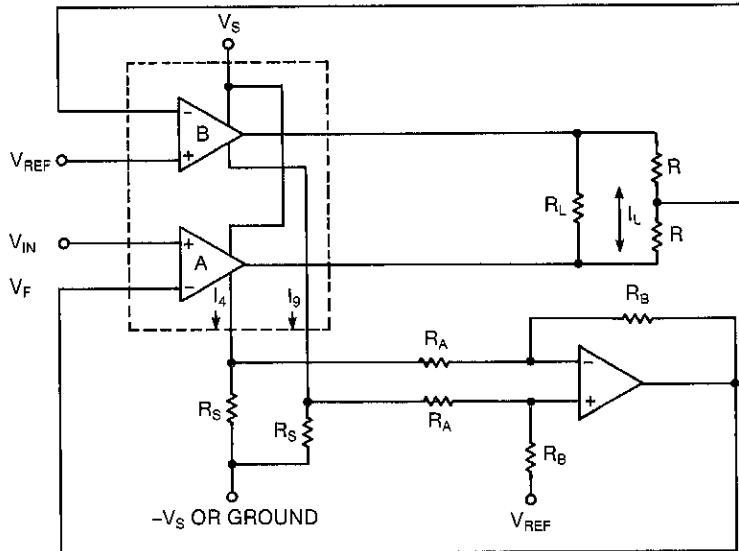

FIGURE 1

Dwg. No. W-162

4

CURRENT-SENSE TRANSCONDUCTANCE AMPLIFIER

The ULN-3753B/W current-sense terminals can be used to obtain a transconductance function. This characteristic is commonly used in motor control applications such as voice coil servo or micro-stepping positioning systems found in many computer disk drives.

Figure 1 shows a ULN-3753W dual amplifier connected as a transconductance amplifier. In this example, amplifier B is used as a slave to amplifier A. Feedback from the current-sensing resistors (R_S) in the emitters of the output current-sinking transistors, is applied to the summing network and scaled to the inverting input of amplifier A where it is compared to the input voltage. The current-sensing feedback imparts a transconductance characteristic to the amplifier's transfer function. That is, the voltage developed across the sensing resistors is directly

proportional to the output current. Using this voltage as a feedback source allows expressing the gain of the circuit as output current in amperes vs. input voltage in volts. The gain assumes the dimensions of a transconductance function, expressed in mhos.

The negative-feedback forces the amplifier to adjust the output current to attain a value such that the feedback voltage equals the applied input voltage. The transfer function of the transconductance amplifier is approximately:

$$I_L / (V_{IN} - V_{REF}) = R_A / R_B R_S$$

In the figure, resistors R_A , R_B , and R_S define the transconductance gain. To avoid limiting the transconductance amplifier's output compliance (swing capability), low-value current-sensing resistors (R_S) should be used.

APPLICATIONS

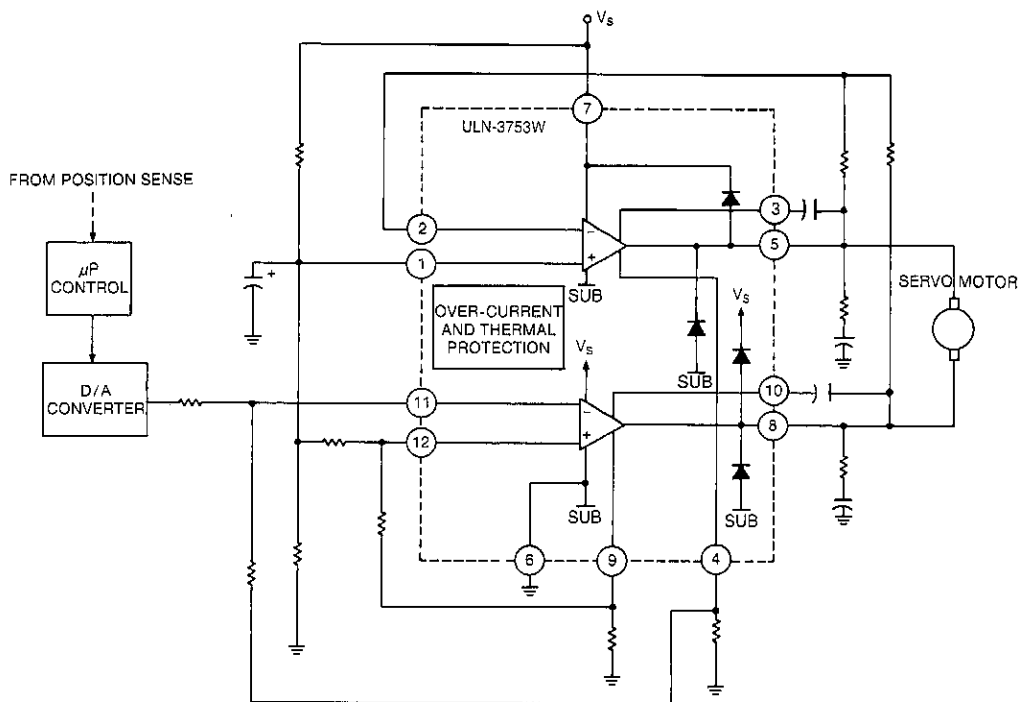

Dwg. No. W-163

FIGURE 2

DIGITALLY CONTROLLED POSITION SERVO

In a position-control application, a microprocessor is often used to control a servomotor's shaft angle or to control position as in a disk drive application. The circuit requires small-signal input op amps, drivers, and power output stages. The circuit derives its input from the D/A converter whose output is determined by a code from the controlling microprocessor and related digital control circuitry. The sensed position signal normally undergoes processing and comparison with the desired position, through the microprocessor system that produces an error signal to control the servo amplifier's output.

The circuit includes thermal and short-circuit

protection, matching and thermal tracking inherent to monolithic construction. The configuration shown in Figure 2 uses a ULN-3753W dual power operational amplifier whose two independent outputs are connected in a push-pull, H-bridge arrangement. The IC's outputs also include clamping diodes with current-handling capacity equal to that of the output drivers.

The current-sense pins (4 and 9) provide access to the emitters of the H-bridge current sinks, thereby providing convenient output current sensing, while allowing separate low-current signal ground returns.

APPLICATIONS

TWO-PHASE 60 Hz AC MOTOR DRIVER

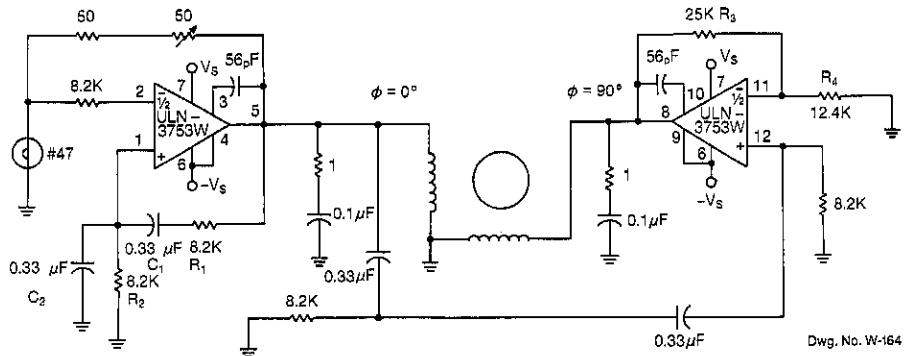

FIGURE 3

THREE-PHASE 400 Hz AC MOTOR DRIVER

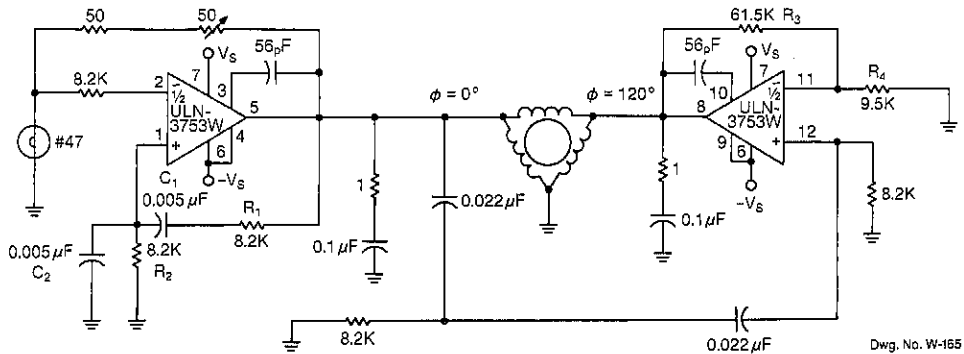

FIGURE 4

N-PHASE MOTOR DRIVE

Because of its high amplification factor and built-in power-output stage, an integrated power operational amplifier makes a convenient driver for ac motors. One op amp can be configured as an oscillator to generate the required ac signal. The power-output stage, of course, supplies the high-current drive to the motor.

As shown in the motor-drive circuits in Figure 3 and 4, the controlling op amp is configured as a Weinbridge oscillator. The R_1C_1 , R_2C_2 feedback networks determine the oscillation frequency, according to the following expression:

$$f_0 = 1/(2\pi R_1R_2C_1C_2)$$

By varying either R_1 or R_2 , the oscillator frequency can be adjusted over a narrow range.

The R_3/R_4 ratio sets the second amplifier's gain to compensate for signal attenuation occurring in the phase shifters.

The circuits can be driven from an external source, such as a pulse or square wave, setting the gain of the left-hand amplifier to a level less than that required for oscillation. The RC feedback networks then function as an active filter causing the outputs to be sinusoidal.

APPLICATIONS

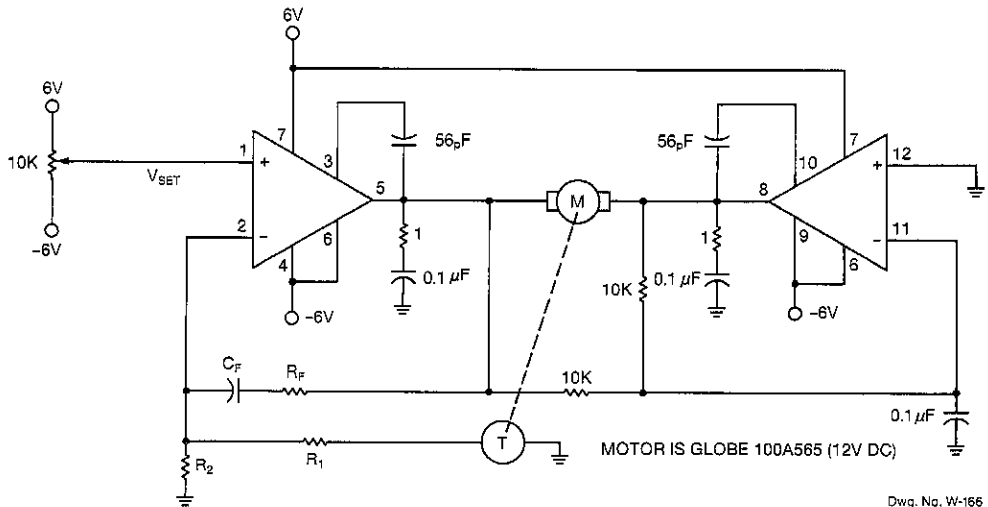

FIGURE 5

DC MOTOR SPEED CONTROL

In addition to the synchronous ac motor drives described above, the ULN-3753B/W can be used to provide accurate speed control of dc motors. Figure 5 shows a closed-loop system for controlling the speed of a 12V dc motor. The circuit provides bidirectional speed control. The amplifiers' push-pull configuration ensures a full rail-to-rail voltage swing (minus the output stages' saturation drops) across the motor in either direction.

The circuit uses a mechanically-coupled tachometer to provide speed-stabilizing feedback to the first amplifier section. The motor's speed and direction of rotation is set by adjusting the 10 kΩ poten-

tiometer at the amplifier's noninverting input. The motor speed, in rpm, is given by the following expression:

$$S = V_{SET}(R_1 + R_2)/.0027 R_2$$

The $R_F C_F$ feedback network prevents oscillation by compensating for the inherent dynamic mechanical lag of the motor. The $R_F C_F$ time constant is selected to match the particular motor's response or dynamic time constant. This should yield a good starting point for stabilizing the system with optimum response achieved by varying the compensating capacitor.

ULN-3755B AND ULN-3755W DUAL POWER OPERATIONAL AMPLIFIERS

FEATURES

- Operating Supply Range ± 3 to ± 20 Volts
- Output Current to ± 3.5 A Peak
- Output Current Limiting
- Output Current Sensing
- High Output-Voltage Swing
- Low Crossover Distortion
- Low Input Offset Voltage
- Unity-Gain Stable
- High Open-Loop Gain
- Output Protection Diodes
- Thermal Shutdown Protection
- Excellent Supply and Common-Mode Rejection
- Single or Dual In-Line Power Packages

APPLICATIONS

- Dual Half-Bridge and Full-Bridge Motor Drivers
 - Linear Servo Motors
 - Voice Coil Motors
 - AC and DC Motors
 - Microstepping Applications
- Power Transconductance Amplifier
- Audio Power Amplifier
 - Stereo or BTL
- Power Oscillator/Amplifier
- Dual Bipolar Voltage Regulator

Consisting of two high-power operational amplifier circuits in a single in-line power-tab package or a batwing dual in-line package, the ULN-3755B and ULN-3755W are specifically designed to drive high-current linear servo loads such as voice coil motors used in disc-drive applications. Their building block design concept also makes them ideal for a wide variety of other motor drive applications, for use as audio power amplifiers, power oscillators, and linear voltage regulators. Low crossover distortion eliminates servo hunting under null conditions and is required for most audio applications.

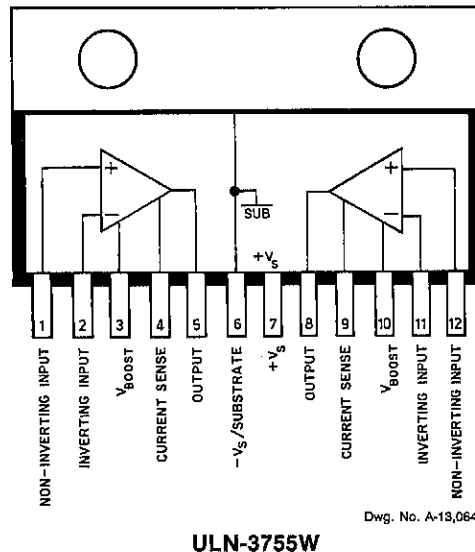
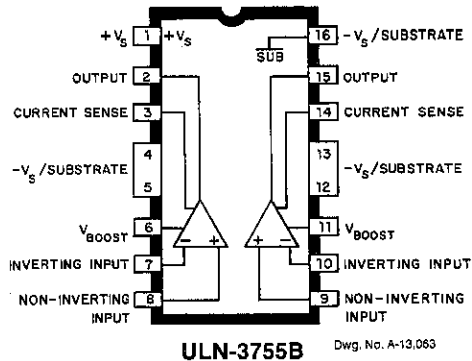

The ULN-3755B is furnished in a 16-pin dual in-line package with copper heat-sink contact tabs. For higher power requirements, the ULN-3755W is supplied in a 12-pin single in-line power tab package.

Continued next page

**ULN-3755B AND ULN-3755W
DUAL POWER OPERATIONAL AMPLIFIERS**

The inputs are designed to allow a wide common mode range from the negative supply, (or ground in single supply applications) to within approximately two volts of the positive supply. Common-mode and power supply rejection are in excess of 60 dB. The amplifiers' wide output swing is complemented by current sensing, which is referenced to the negative supply and allows for feedback as required to produce a transconductance characteristic.

Separate supply pins are provided for the low-level input and high-level output circuits to allow voltage boost or bootstrapping to maximize output swing.

The ULN-3755B (batwing DIP) can typically dissipate 6 W at a tab temperature of +70°C. The lead configuration enables easy attachment of a heat sink while fitting a standard socket or

printed wiring board layout. The ULN-3755W (SIP) can safely dissipate significantly higher power levels with appropriate heat sinking. With either package configuration, the heat sink is at the negative supply, or ground in a single-ended application.

ABSOLUTE MAXIMUM RATINGS

Supply Voltage Differential (+V _s to -V _s)	40 V
Peak Supply Voltage (50 ms)	45 V
Continuous Output Current		
I _{OUT} (V _s = ±15 V)	±2.0 A
(V _s = ±6 V)	±2.5 A
Peak Output Current, I _{OUT} (50 ms)	±3.5 A
Package Power Dissipation, P _D	See Graphs
Operating Temperature Range, T _A	-20°C to +85°C
Storage Temperature Range, T _s	-55°C to +125°C

**ALLOWABLE AVERAGE PACKAGE POWER DISSIPATION
AS A FUNCTION OF TEMPERATURE**

ULN-3755B

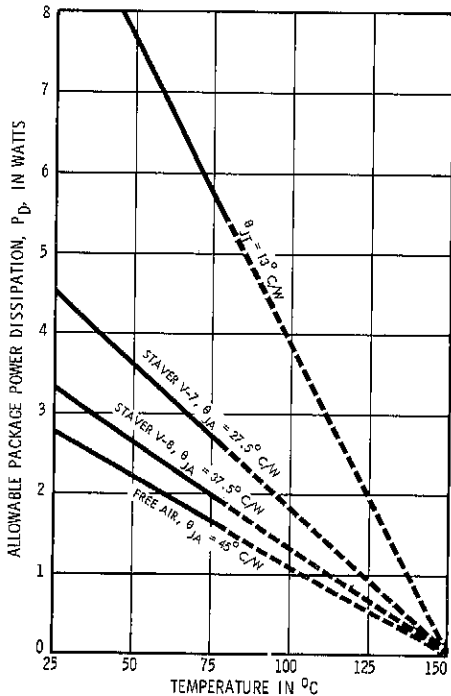

Dwg. No. A-11,793B

ULN-3755W

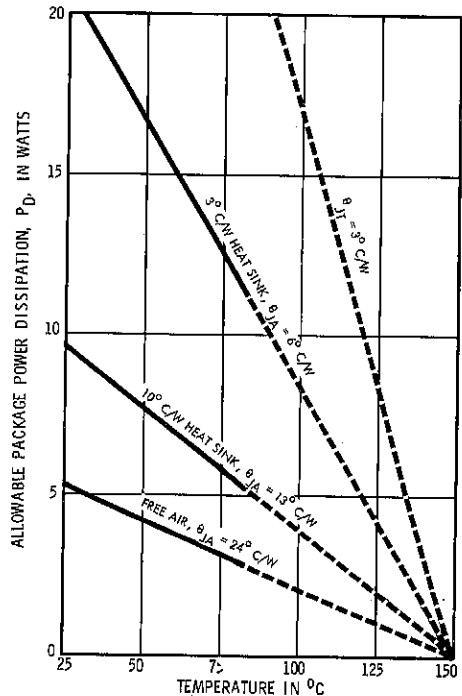

Dwg. No. A-11,794A

ULN-3755B AND ULN-3755W
DUAL POWER OPERATIONAL AMPLIFIERS

ELECTRICAL CHARACTERISTICS at $T_A = +25^\circ\text{C}$, $T_{TAB} \leq +70^\circ\text{C}$, $V_S = \pm 6.0\text{ V}$, $V_{BOOST} = +9.0\text{ V}$, each amplifier tested separately (unless otherwise specified)

Characteristic	Test Conditions	Limits			
		Min.	Typ.	Max.	Unit
Functional Supply Voltage Range	$+V_S$ to $-V_S$	6.0	—	40	V
Quiescent Supply Current	I_{BOOST} (Each Amp.)	—	7.0	10	mA
	$+I_S$ (Total)	—	75	130	mA
Input Bias Current	$V_{OUT} = 0$	—	-80	-1000	nA
Input Offset Voltage	$V_{OUT} = 0$, $I_{OUT} = 0$	—	± 1.0	± 10	mV
Input Offset Volt. TC†	Over Op. Temp. Range	—	-15	—	$\mu\text{V}/^\circ\text{C}$
Input Offset Current	$V_{OUT} = 0$, $I_{OUT} = 0$	—	10	100	nA
Input Noise Voltage†	BW = 40 Hz to 15 kHz	—	4.0	—	μV
Input Noise Current†	BW = 40 Hz to 15 kHz	—	60	—	pA
Crossover Distortion†	$P_{OUT} = 50\text{ mW}$, $R_L = 4\Omega$	—	0.2	—	%
Common Mode Rejection	$\Delta V_{CM} = 3\text{ V}$	60	85	—	dB
Input Common Mode Range*	$V_S = \pm 6\text{ V}$	-6.3	—	+4.0	V
	$V_S = \pm 15\text{ V}$	-15.3	—	+13	V
Open-Loop Voltage Gain	$f = 0$	80	100	—	dB
Slew Rate	$V_{IN} = V_{OUT} = 6\text{ Vpp}$	0.5	1.0	—	V/ μs
Gain-Bandwidth Product†	$A_V = 40\text{ dB}$	—	800	—	kHz
Channel Separation†	$I_{OUT} = 100\text{ mA}$, $f = 1\text{ kHz}$	—	60	—	dB
Output Voltage Swing	$I_{OUT} = 1\text{ A}$, $V_{BOOST} = +6\text{ V}$	9.0	9.5	—	Vpp
	$I_{OUT} = 1\text{ A}$, $V_{BOOST} = +9\text{ V}$	9.5	10.1	—	Vpp
Supply Voltage Rejection	$+V_S$, $\Delta V = 1\text{ V}$	60	85	—	dB
	$-V_S$, $\Delta V = 1\text{ V}$	60	80	—	dB
Thermal Resistance, Θ_{JT}^*	ULN-3755B	—	—	15	$^\circ\text{C}/\text{W}$
	ULN-3755W	—	—	3.0	$^\circ\text{C}/\text{W}$
Thermal Shutdown Temp. †		—	165	—	$^\circ\text{C}$

*This parameter is tested to a lot sample plan only.

†Typical values given for circuit design information only.

NON-INVERTING AMPLIFIER

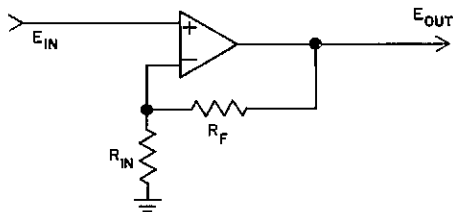

$$\frac{E_{OUT}}{E_{IN}} = 1 + \frac{R_F}{R_{IN}}$$

IF $R_F = 0$ or $R_{IN} = \infty$ THEN $E_{OUT} = E_{IN}$

INVERTING AMPLIFIER

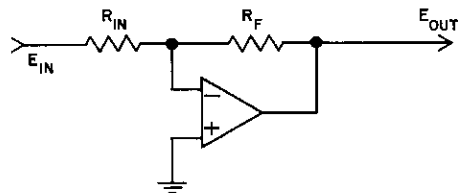

$$\frac{E_{OUT}}{E_{IN}} = -\frac{R_F}{R_{IN}}$$

Dwg. No. A-13,062

4

TYPICAL CHARACTERISTICS

INPUT OFFSET VOLTAGE AS A FUNCTION OF TEMPERATURE

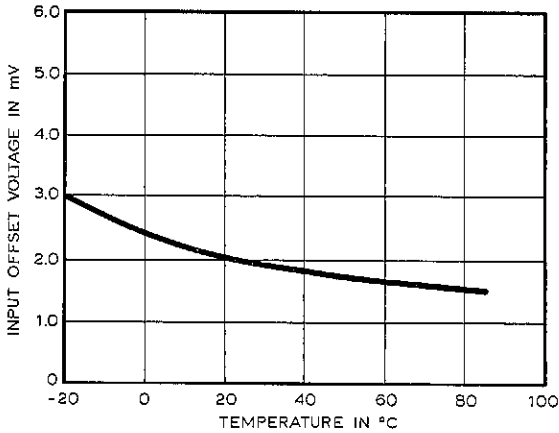

Dwg. No. A-13,294

INPUT BIAS CURRENT AS A FUNCTION OF TEMPERATURE

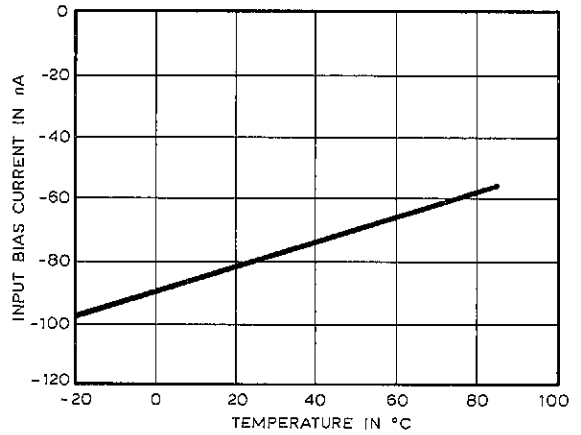

Dwg. No. A-13,295

OPEN-LOOP VOLTAGE GAIN AND PHASE AS A FUNCTION OF FREQUENCY

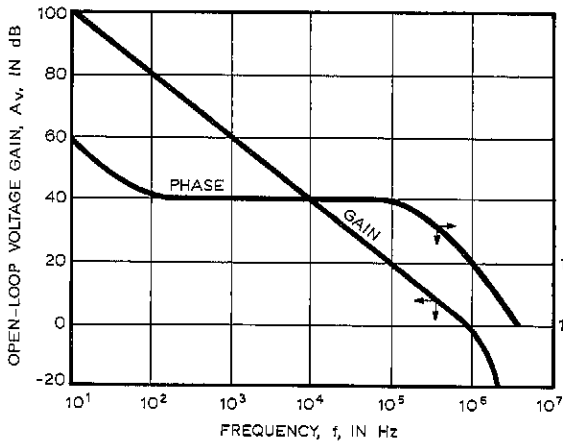

Dwg. No. A-13,296

OPEN-LOOP VOLTAGE GAIN AS A FUNCTION OF TEMPERATURE

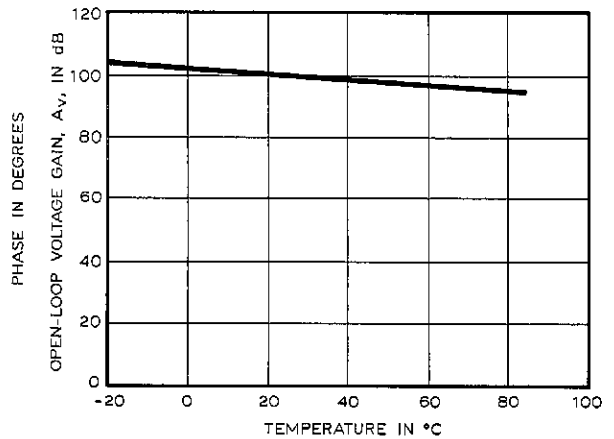

Dwg. No. A-13,297

TYPICAL CHARACTERISTICS

OUTPUT VOLTAGE SWING AS A
 FUNCTION OF OUTPUT CURRENT

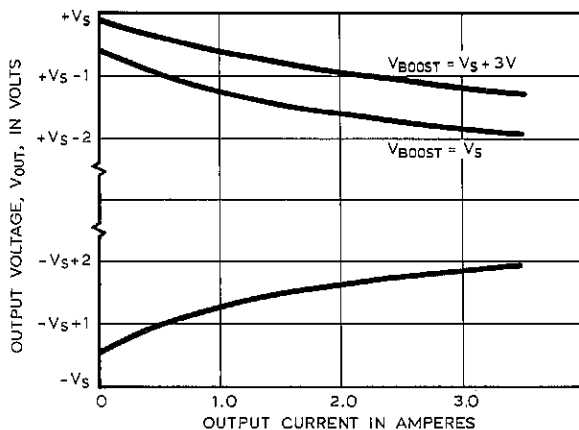

Dwg. No. A-13,298

4

SUPPLY CURRENT AS A FUNCTION
 OF SUPPLY VOLTAGE

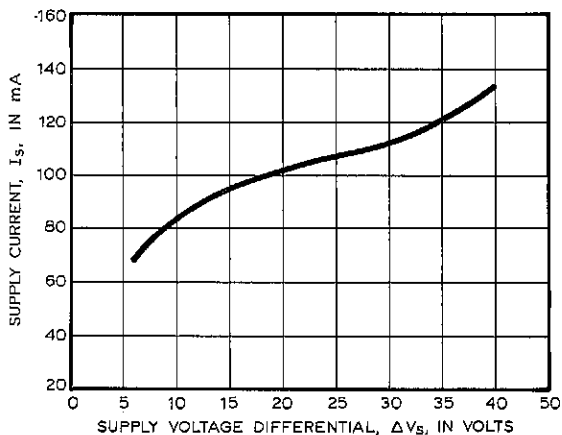

Dwg. No. A-13,299

BOOST CURRENT AS A FUNCTION
 OF BOOST VOLTAGE

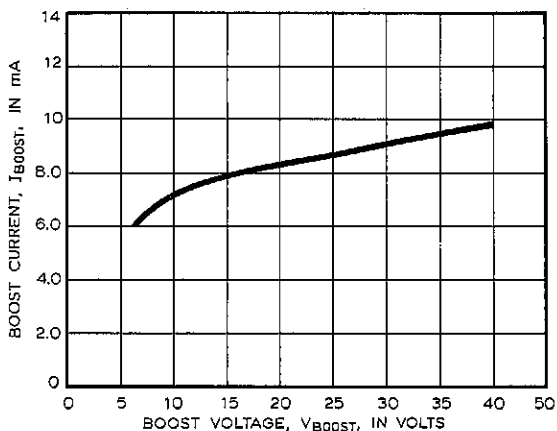

Dwg. No. A-13,300

APPLICATIONS

Current-Sense Transconductance Amplifier

The ULN-3755B/W current-sense terminals can be used to obtain a transconductance function. This characteristic is commonly used in motor control applications such as voice coil servo or micro-stepping positioning systems found in many computer disc drives.

Figure 1 shows a ULN-3755W dual amplifier connected as a transconductance amplifier. In this example, amplifier B is used as a slave to amplifier A. Feedback from the current sensing resistors (R_S) in the emitters of the output current sinking transistors, is applied to the summing network and scaled to the inverting input of amplifier A where it is compared to the input voltage. The current sensing feedback imparts a transconductance characteristic to the amplifier's transfer function. That is, the voltage developed across the sensing resistors is directly proportional to the output current. Using this voltage as a feedback source allows expressing the gain of the circuit as output current in amperes vs. input voltage in volts. The gain thus assumes the dimensions of a transconductance function, expressed in mhos.

The negative-feedback forces the amplifier to adjust the output current to attain a value such that the feedback voltage equals the applied input voltage. The transfer function of the transconductance amplifier is approximately:

$$I_L = (V_{IN} - V_{REF}) = R_A/R_B R_S$$

In the figure, resistors R_A , R_B , and R_S define the transconductance gain. To avoid limiting the transconductance amplifier's output compliance (swing capability), low-value current-sensing resistors (R_S) should be used.

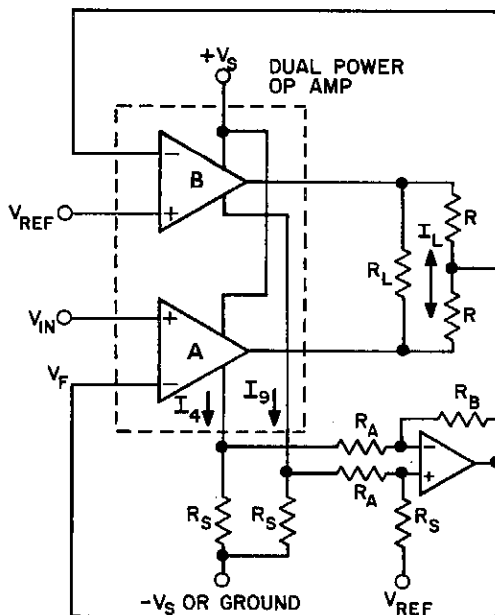

Dwg. No. 13,092

FIGURE 1
 CURRENT-SENSE TRANSCONDUCTANCE AMPLIFIER

APPLICATIONS

Digitally Controlled Position Servo

In a position-control application, a microprocessor is often used to control a servomotor's shaft angle or to control position as in a disk drive application. The circuit requires small-signal input op amps, drivers, and power output stages. The circuit derives its input from the D/A converter, the output of which is determined by a code from the controlling microprocessor and related digital-control circuitry. The sensed position signal normally undergoes processing and comparison with the desired position, through the micro-processor system that produces an error signal to control the servo amplifier's output.

The circuit includes thermal and short-circuit protection, matching and thermal tracking inherent to monolithic construction. The configuration shown in Figure 2 uses a ULN-3755W dual power operational amplifier whose two independent outputs are connected in a push-pull, H-bridge arrangement. The IC's outputs also include clamping diodes with current-handling capacity equal to that of the output drivers.

The current-sense pins (4 and 9) provide access to the emitters of the H-bridge current sinks, thereby providing convenient output current sensing, while allowing separate low-current signal ground returns.

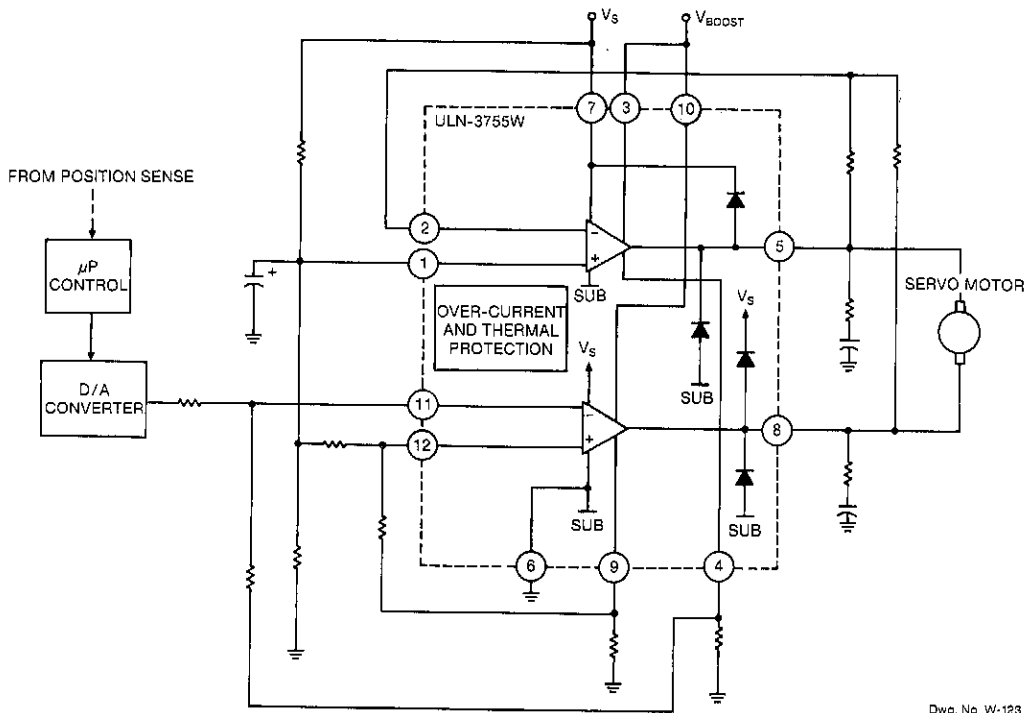

FIGURE 2
DIGITALLY CONTROLLED POSITION SERVO

4

APPLICATIONS

Increased Output-Voltage Swing

If a voltage higher than the supply is applied to the ULN-3755W's boost pins, as shown, the positive output swing is limited only by the saturation resistance of the output transistors (typically less than 0.5 ohms). For example, with a 12 V supply, the circuit typically supplies a 10.5 Vpp output swing at 1 A output current. Note that the externally-supplied boost voltage should be at least 3 V higher than the load supply voltage. This criterion satisfied, the boost voltage can be any value within the IC's 40 V absolute maximum rating.

Although the boost feature provides important additional output swing at the amplifier's full rated current, the IC's boost input requires only a low, unregulated current. This can be obtained from inexpensive, modular dc to dc converters, a simple overwinding in the motor, or a voltage doubler from the motor's driven phases.

An example of a simple voltage doubler boost supply is shown in Figure 3. This circuit affects the doubling by connecting a series diode-capacitor between the main supply and each end of the load.

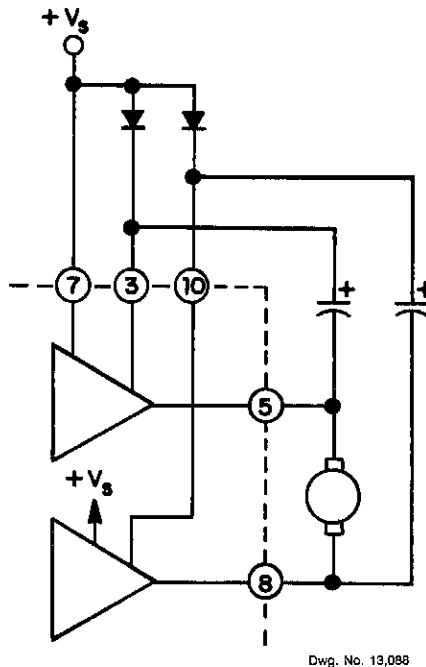

FIGURE 3
VOLTAGE DOUBLER BOOST SUPPLY

APPLICATIONS

N-Phase Motor Drive

Because of its high amplification factor and built-in power-output stage, an integrated power operational amplifier makes a convenient driver for ac motors. One op amp can be configured as an oscillator to generate the required ac signal. The power-output stage, of course, supplies the high-current drive to the motor.

As shown in the motor-drive circuits in Figure 4, the controlling op amp is configured as a Weinbridge oscillator. The R_1C_1 , R_2C_2 feedback networks determine the oscillation frequency, according to the following expression:

$$f_o = 1/(2\pi \sqrt{R_1R_2C_1C_2})$$

By varying either R_1 or R_2 , the oscillator frequency can be adjusted over a narrow range.

The R_3/R_4 ratio sets the second amplifier's gain to compensate for signal attenuation occurring in the phase shifters. A separate boost supply can be used to obtain additional output-swing capability.

The circuits can be driven from an external source, such as a pulse or square wave, setting the gain of the left-hand amplifier to a level less than that required for oscillation. The RC feedback networks then function as an active filter causing the outputs to be sinusoidal.

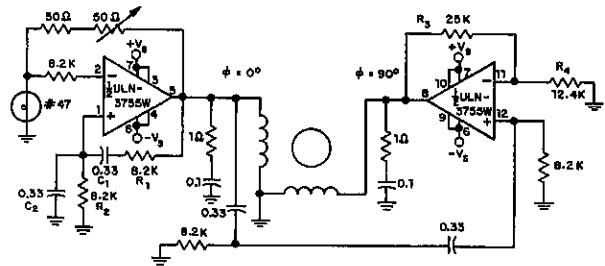

Dwg. No. 13,089

FIGURE 4a
TWO-PHASE 60 HZ AC MOTOR DRIVER

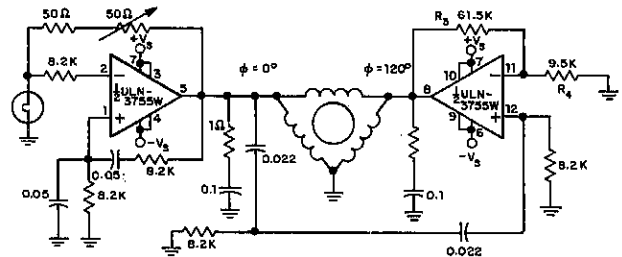

Dwg. No. 13,090

FIGURE 4b
THREE-PHASE 400 HZ AC MOTOR DRIVER

4

APPLICATION TIPS

1. Due to the nature of the composite PNP/NPN output structure, all applications of these devices require use of an output R-C compensation network, as shown in Figures 2, 4, and 5. Values shown are typical and will vary somewhat depending on load impedance.
2. As is the usual practice in high-gain power circuits, input and output grounds should be kept separate.
3. The current sense pins are the emitters of the power driver output totem poles and must be grounded or returned to the negative supply if not used for current sensing.
4. Provide good high-frequency supply bypass (ceramic or film capacitor).
5. All input, output, and supply leads should be properly dressed and kept as short as possible.
6. If the boost or bootstrapping capability is not used, the boost pins must be connected to the positive supply.

UDN-5725M

DUAL PERIPHERAL/POWER DRIVER

—Enhanced Output Capability

FEATURES

- DTL/TTL/PMOS/CMOS Compatible
- Low Input Current
- Continuous Output Current to 1 A
- 70 V Output Standoff Voltage
- Low Supply-Current Requirement

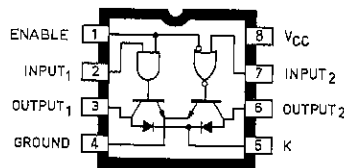

Dwg. No. 13,242

The UDN-5725M power driver combines NAND and NOR logic gates in a configuration particularly useful with small brushless dc motor drivers. The integrated circuit includes high-current saturated output transistors and transient-suppression diodes. It can be used in many applications beyond the capabilities of standard logic buffers: With inputs tied together, one of two loads is energized by a single input signal.

Additional applications include driving peripheral loads such as solenoids, light-emitting diodes, memories, heaters, and incandescent

lamps with peak load currents of up to 1.2 A.

Each of the output transistors is capable of sinking 800 mA continuously at 55°C, or 650 mA at 85°C. In the OFF state, the drivers will withstand at least 70 V.

The UDN-5725M is supplied in a miniature 8-pin dual-in-line plastic package with a copper lead frame for superior package power dissipation ratings.

For applications requiring output currents of up to 700 mA, Series UDN-5740M is recommended.

ABSOLUTE MAXIMUM RATINGS

at $T_A = +25^\circ\text{C}$

Output Off-State Voltage, V_{OFF}	70 V
Output On-State Sink Current, I_{ON} (continuous)	1.0 A†
(peak)	1.2 A
Logic Supply Voltage, V_{CC}	16 V
Input Voltage, V_{IN}	30 V
Suppression Diode Off-State Voltage, V_{OFF}	70 V
Suppression Diode On-State Current, I_{ON}	1.0 A
Allowable Package Power Dissipation, P_D	1.5 W*
Operating Free-Air Temperature Range, T_A	-20°C to +85°C
Storage Temperature Range, T_S	-55°C to +150°C

*Derate at the rate of 12.5 mW/°C above $T_A = +25^\circ\text{C}$.

†Limited by P_D .

4

ALLOWABLE AVERAGE PACKAGE POWER DISSIPATION
 AS A FUNCTION OF TEMPERATURE

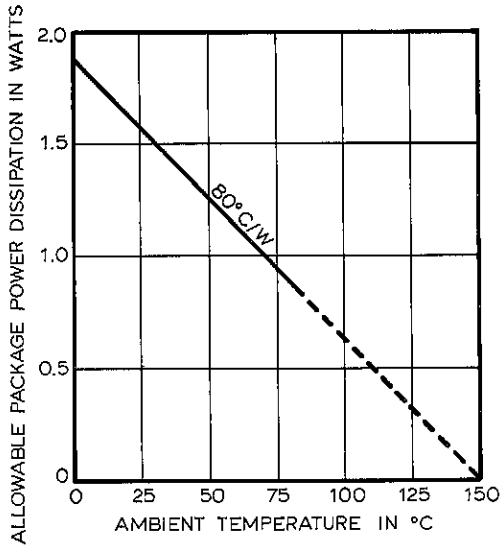

Dwg. No. 13,243

TYPICAL APPLICATION

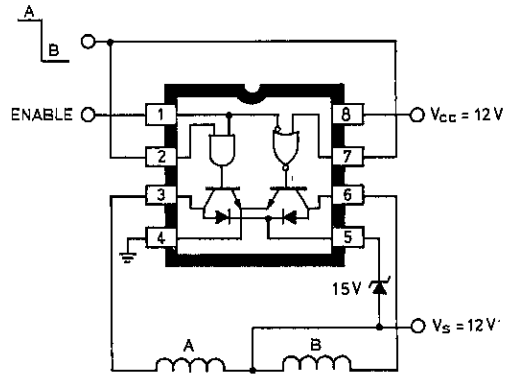

Dwg. No. 13,244



RECOMMENDED OPERATING CONDITIONS

Operating Condition	Min.	Nom.	Max.	Units
Supply Voltage, V _{CC}	4.75	12	14	V
Output Current, I _{ON}	—	—	650	mA
Operating Temperature Range	0	+25	+85	°C

TRUTH TABLE

STROBE INPUT	PHASE INPUTS		OUTPUTS	
	1	2	1	2
H	H	H	L	H
H	H	L	L	L
H	L	L	H	L
H	L	H	H	H
L	X	X	H	H

ELECTRICAL CHARACTERISTICS over recommended operating temperature range
(unless otherwise noted)

Characteristic	Symbol	Test Conditions					Limits				Notes
		Temp.	V _{CC}	Enable Input	Other Inputs	Output	Min.	Typ.	Max.	Units	
Output Reverse Current	I _{CEX}	—	4.75	0.8 V	2.0 V	70 V	—	—	100	μA	—
			4.75	0.8 V	0.8 V	70 V	—	—	100	μA	—
Output Voltage	V _{CE(sat)}	—	14	2.0 V	2.0 V	0.6 A	—	0.4	0.6	V	—
			14	2.0 V	2.0 V	0.8 A	—	0.7	1.0	V	—
			14	2.0 V	2.0 V	1.0 A	—	0.9	1.2	V	3
			14	2.0 V	0.8 V	0.6 A	—	0.4	0.6	V	—
			14	2.0 V	0.8 V	0.8 A	—	0.7	1.0	V	—
			14	2.0 V	0.8 V	1.0 A	—	0.9	1.2	V	3
	V _{CE(sus)}	+25°C	14		0 V	0.8 A	50	—	—	V	3,4
			14		2.0 V	0.8 A	50	—	—	V	3,4
Input Voltage	V _{IN(1)}	—	—	—	—	2.0	—	—	V	—	
	V _{IN(O)}	—	—	—	—	—	—	0.8	V	—	
Input Current	I _{IN(O)}	—	12.6	0.4 V	30 V	—	—	5.0	25	μA	1
	I _{IN(1)}	—	12.6	30 V	0 V	—	—	5.0	25	μA	1
Enable Input Current	I _{IN(O)}	—	12.6	0.4 V	30 V	—	—	10	50	μA	—
	I _{IN(1)}	—	12.6	30 V	0 V	—	—	10	50	μA	—
Input Clamp Volt.	V _{CLAMP}	—	4.75	−12 mA	—	—	—	−1.5	V	—	
Diode Leakage Current	I _R	+25°C	5.0	0 V	0 V	Open	—	—	100	μA	2
			5.0	0 V	0 V	1.0 A	—	1.5	2.0	V	—
Diode Forward Voltage	V _F	+25°C	5.0	0 V	0 V	0.6 A	—	1.9	2.5	V	3
			5.0	0 V	0 V	1.0 A	—	1.9	2.5	V	3
Supply Current (Total Package)	I _{CC(1)}	+25°C	12.6	0 V	0 V	—	—	3.9	5.0	mA	—
			12.6	0 V	2.0 V	—	—	3.9	5.0	mA	—
	I _{CC(O)}	+25°C	12.6	2.0 V	0 V	—	—	22	30	mA	—
			12.6	2.0 V	2.0 V	—	—	22	30	mA	—

NOTES:

1. Except ENABLE input, each input tested separately.
2. Diode leakage current measured at V_R = 70 V.
3. Pulse Test.
4. L_L = 3 mH.

4

SWITCHING CHARACTERISTICS at $T_A = +25^\circ\text{C}$, $V_{CC} = 5.0\text{ V}$

Characteristic	Symbol	Test Conditions	Limits			Notes
			Min.	Max.	Units	
Turn-On Delay Time	t_{pd0}	$V_s = 30\text{ V}$, $R_L = 100\text{ (10 W)}$, $C_L = 15\text{ pF}$	—	500	ns	1, 2
Turn-Off Delay Time	t_{pd1}	$V_s = 30\text{ V}$, $R_L = 100\text{ (10 W)}$, $C_L = 15\text{ pF}$	—	750	ns	1, 2

NOTES: 1. Capacitance value specified includes probe and test fixture capacitance.
 2. Voltage values shown in test circuit waveforms are with respect to network ground.

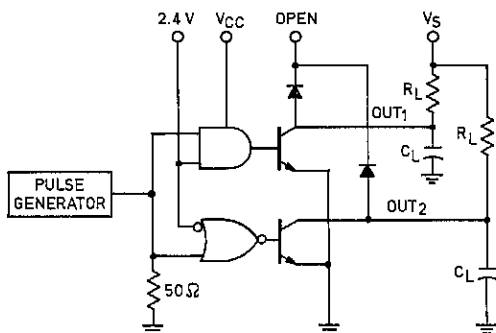

Dwg. No. 13,245

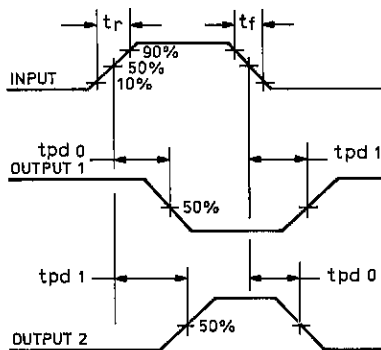

Dwg. No. 13,246

INPUT-PULSE CHARACTERISTICS

$V_{IN(0)} = 0\text{ V}$	$t_r = 7\text{ ns}$	$t_f = 1\text{ }\mu\text{s}$
$V_{IN(1)} = 3.5\text{ V}$	$t_f = 14\text{ ns}$	PRR = 500kHz

UDN-7078W QUAD HIGH-CURRENT DARLINGTON SWITCH

FEATURES

- Output Voltage to 90V
- 90V Sustaining Voltage
- Output Current to 3A
- TTL, DTL, or CMOS Compatible Inputs
- Internal Transient-Suppression Diodes
- Plastic Single In-Line Package
- Heat-Sink Tab

This quad Darlington array is designed to serve as interface between low-level logic and peripheral power devices such as solenoids, motors, incandescent lamps, heaters, and similar loads up to 270 W per channel. The integrated circuit contains internal transient-suppression diodes that enable use with inductive loads. The input logic is compatible with most TTL, DTL, LSTTL, and 5V CMOS logic. The Darlington array is rated for operation to 90V and is recommended for operation with load currents of 3 A or less.

For maximum power handling capability, the device is supplied in a 12-pin single in-line plastic package with an integral power tab. The tab is at ground potential and needs no insulation. External heat sinks are usually required for proper operation of this device.

Similar quad high-current Darlington switches, for operation with supply voltages to 50V or 80V (35V or 50V sustaining), are UDN-2878W and UDN-2879W.

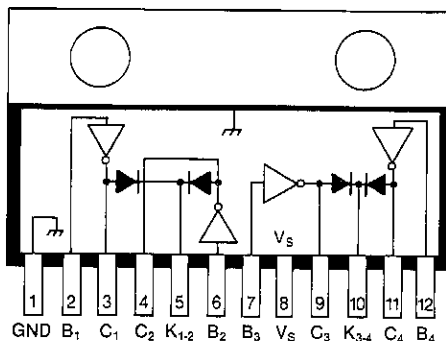

Dwg. No. DS-1015

4

ABSOLUTE MAXIMUM RATINGS at $T_{TAB} < +70^{\circ}\text{C}$

Output Voltage, V_{CE}	90V
Min. Sustaining Voltage, $V_{CE(SUS)}$	90V
Output Current, I_C	3.0A
Supply Voltage, V_S	10V
Input Voltage, V_{IN}	15V
Total Package Power Dissipation, P_D	See Graph
Operating Temperature Range, T_A	-20°C to $+85^{\circ}\text{C}$
Storage Temperature Range, T_S	-55°C to $+150^{\circ}\text{C}$

UDN-7078W
QUAD HIGH-CURRENT DARLINGTON SWITCH

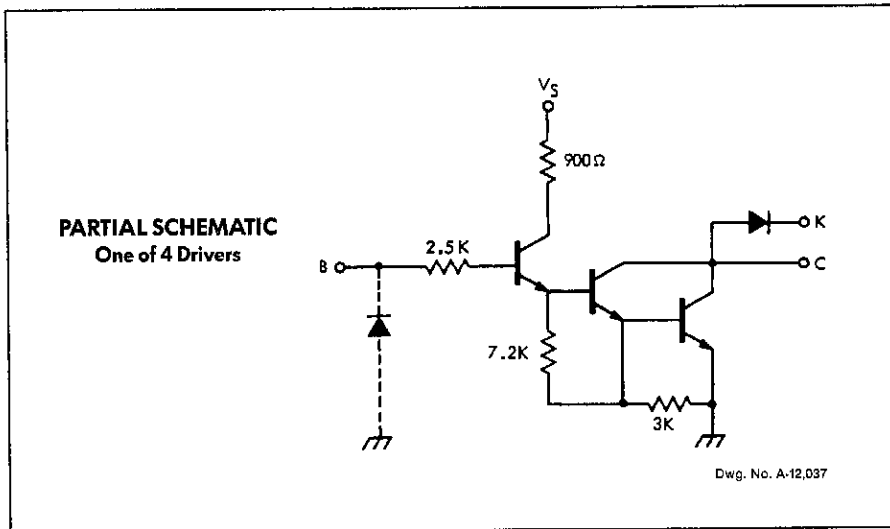

ELECTRICAL CHARACTERISTICS at $T_A = +25^\circ\text{C}$, $T_{\text{tab}} < +70^\circ\text{C}$, $V_S = 5\text{V}$

Characteristic	Symbol	Test Conditions	Limits		Units	
			Min.	Max.		
Output Leakage Current	I_{CEX}	$V_{\text{CE}} = 90\text{V}$	—	100	μA	
Output Sustaining Voltage	$V_{\text{CE(SUS)}}$	$I_{\text{C}} = 2.5\text{A}$	90	—	V	
Output Saturation Voltage	$V_{\text{CE(SAT)}}$	$I_{\text{C}} = 0.5\text{A}$, $V_{\text{IN}} = 2.75\text{V}$	—	1.1	V	
		$I_{\text{C}} = 1.0\text{A}$, $V_{\text{IN}} = 2.75\text{V}$	—	1.3	V	
		$I_{\text{C}} = 2.0\text{A}$, $V_{\text{IN}} = 2.75\text{V}$	—	1.6	V	
		$I_{\text{C}} = 2.5\text{A}$, $V_{\text{IN}} = 2.75\text{V}$	—	1.9	V	
Input Voltage	$V_{\text{IN(ON)}}$	$I_{\text{C}} = 3.0\text{A}$	2.75	—	V	
			—	0.8	V	
Input Current	$I_{\text{IN(O)}}$	$V_{\text{IN}} = 0.8\text{V}$	—	25	μA	
		$V_{\text{IN}} = 2.75\text{V}$	—	550	μA	
		$V_{\text{IN}} = 3.75\text{V}$	—	1.0	mA	
Supply Current per Driver	I_{S}	$I_{\text{C}} = 500\text{mA}$	—	6.0	mA	
Clamp Diode Leakage Current	I_{R}	$V_{\text{R}} = 90\text{V}$	—	50	μA	
Clamp Diode Forward Voltage	V_{F}	$I_{\text{F}} = 2.5\text{A}$	—	2.5	V	
		$I_{\text{F}} = 3.0\text{A}$	—	3.0	V	
Turn-On Delay	t_{PLH}	$0.5 E_{\text{in}}$ to $0.5 E_{\text{out}}$	—	1.0	μs	
Turn-Off Delay	t_{PHL}	$0.5 E_{\text{in}}$ to $0.5 E_{\text{out}}$, $I_{\text{C}} = 3.0\text{A}$	—	1.5	μs	

CAUTION: High-current tests are pulse tests or require heat sinking.

**ALLOWABLE AVERAGE PACKAGE POWER DISSIPATION
 AS A FUNCTION OF TEMPERATURE**

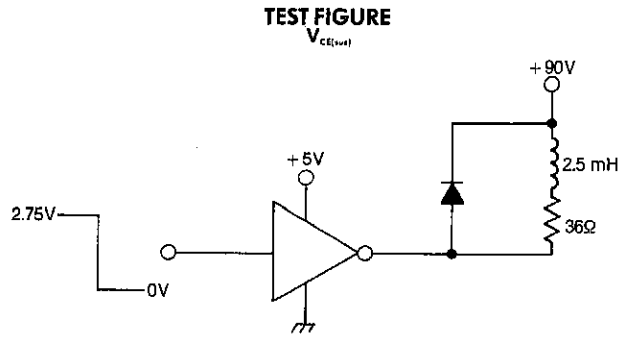
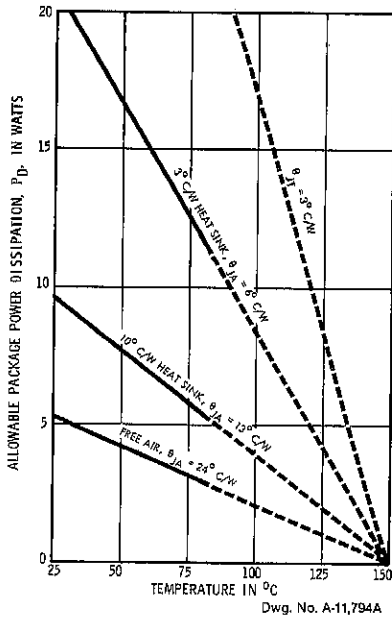

Dwg. No. DS-1016

4

TYPICAL APPLICATION

PRINT-HAMMER DRIVER

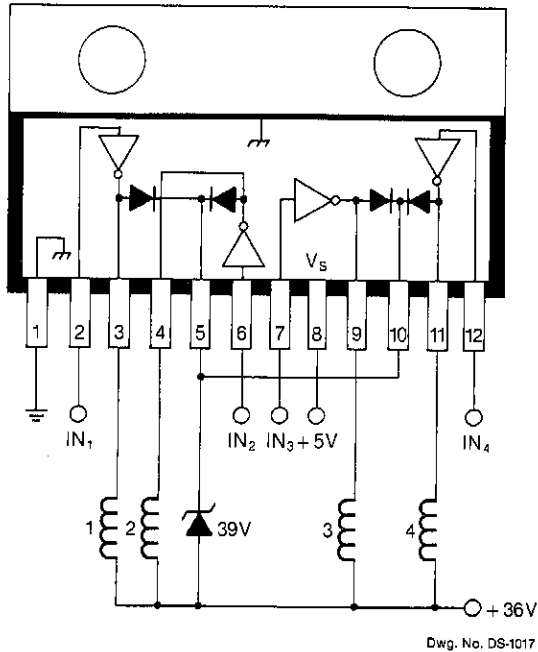

POWER INTEGRATED CIRCUITS FOR MOTOR-DRIVE APPLICATIONS

IMPROVED SYSTEMS PERFORMANCE and reliability, lower component counts, and reduced cost are among benefits offered by space-saving Sprague power interface ICs. Many of the following devices are specifically designed for motor-drive applications. The development of these devices is especially significant in view of the increasing use of

microprocessor-controlled servo and stepper motors.

Combining logic, power, and control in an integrated circuit requires special design techniques and experience. Sprague Electric has long been a leader in peripheral power interface technology.

UCN-4204B AND UCN-4205B STEPPER-MOTOR TRANSLATOR/DRIVERS

UCN-4204B & UCN-4205B INTEGRATED circuits drive permanent magnet stepper motors rated to 1.25 A and 30 V with a minimum of external components.

Internal step logic activates one or two of the four output sink drivers to step the load from one position to the next. The logic is activated when STEP INPUT (pin 10) is allowed to go HIGH. Single-phase (A-B-C-D), two-phase (DA-AB-BC-CD), or half-step (A-AB-B-BC-C-CD-D-DA) opera-

tion, and step-inhibit are selected by connections at pins 9 and 10. The sequence of states is determined by the DIRECTION CONTROL (pin 14).

RECOMMENDED MAX. OPERATING CONDITIONS

Output Voltage, V_{OUT} (UCN-4204B)	15 V
(UCN-4205B-2)	25 V
Output Current, I_{OUT}	1.25 A
Logic Supply Voltage, V_{CC}	4.5 V to 5.5 V
Input Voltage, V_{IN}	5.5 V

L/R STEPPER-MOTOR DRIVE

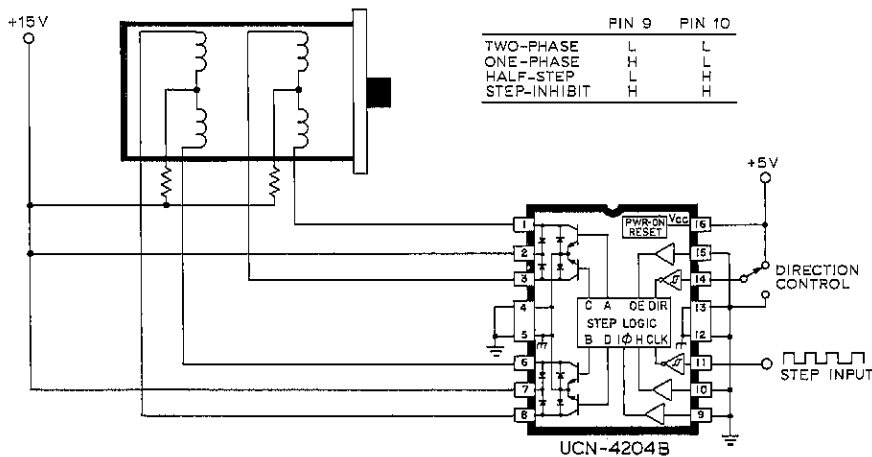

UDN-2953B AND UDN-2954W FULL-BRIDGE MOTOR DRIVERS

THE UDN-2953B AND UDN-2954W are designed for bidirectional, chopped-mode current control of d-c motors with peak start-up currents as high as 3.5 A. The output-current limit is determined by the user's selection of a sensing resistor. The pulse duration is set by an external RC timing network. The chopped mode of operation is characterized by low power-dissipation levels and maximum efficiency.

Internal circuit protection includes thermal shutdown with hysteresis, output transient-suppression diodes, and crossover current protection.

The UDN-2953B is supplied in a 16-pin DIP with heat-sink contact tabs. The UDN-2954W, with increased allowable package power dissipation, is supplied in a 12-lead single in-line power tab package. In both case styles, the heat sink is at ground potential and needs no insulation.

RECOMMENDED MAX. OPERATING CONDITIONS

Motor Supply Voltage, V_{BB}	7.5 V to 50 V
Continuous Output Current, I_{OUT}	± 2.0 A
Peak Output Current, I_{OP}	± 3.5 A
Logic Supply Voltage, V_{CC}	4.5 V to 15 V
Input Voltage, V_{IN}	24 V

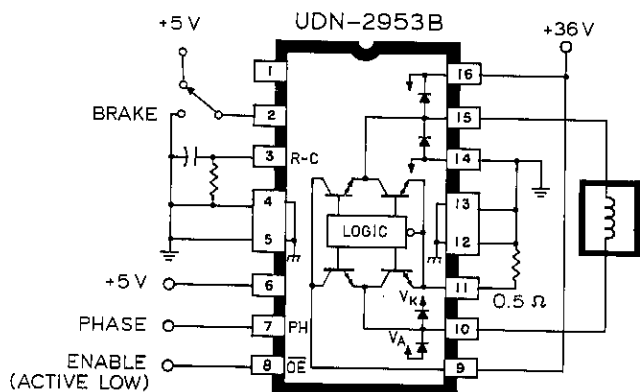

Dwg. No. A-12,649

**UDN-2878W AND UDN-2879W
QUAD DARLINGTON SWITCHES**

THE UDN-2878W AND UDN-2879W drive motor windings at up to 200 watts per channel. The integrated circuits include transient-suppression diodes and input logic that is compatible with most TTL, LS TTL, and 5 V CMOS. The 12-pin single in-line package allows maximum power-handling capability.

RECOMMENDED MAX. OPERATING CONDITIONS

Load Voltage, V_{CC} (UDN-2878W)	35 V
(UDN-2879W)	50 V
Continuous Output Current, I_C	4 A
Peak Output Current, I_{CP}	5 A
Logic Supply Voltage Range, V_S	4.5 to 7.0 V
Input Voltage, V_{IN}	V_S

STEPPER-MOTOR DRIVE

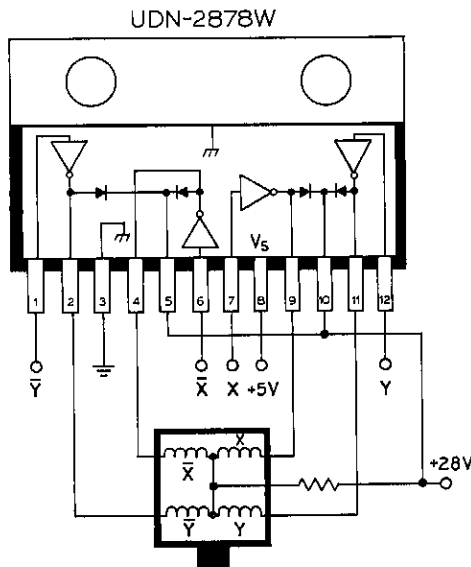

DWG. NO. A-11,975

**2-PHASE, UNIPOLAR
INPUT WAVEFORMS**

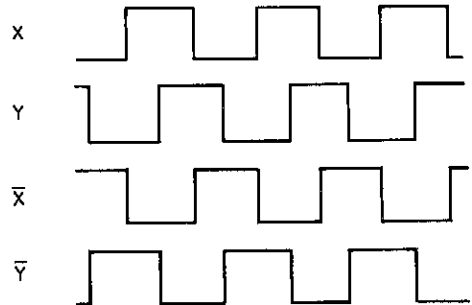

Dwg. No. A-11,795

UDN-2965W-2 DUAL HIGH-POWER MOTOR DRIVER

THE UDN-2965W-2 INTEGRATED CIRCUIT drives stepper motors in the full-bridge configuration. It is a high-power, multi-function interface driver that combines sink and source drivers, gain and level shifting, thermal shutdown circuitry, and pulse-width modulated current control. Output current, threshold voltage, and hysteresis are preset or may be externally set by the user. The UDN-2965W-2 is also well-suited for use as a dual high-power hammer driver.

RECOMMENDED MAX. OPERATING CONDITIONS

Supply Voltage Range, V_{CC}	20 V to 50 V
Output Current, I_{OUT}	± 4.0 A
Input Voltage, V_{IN}	5.5 V

4

BIPOLAR STEPPER-MOTOR DRIVE (Pulse-Width Modulated)

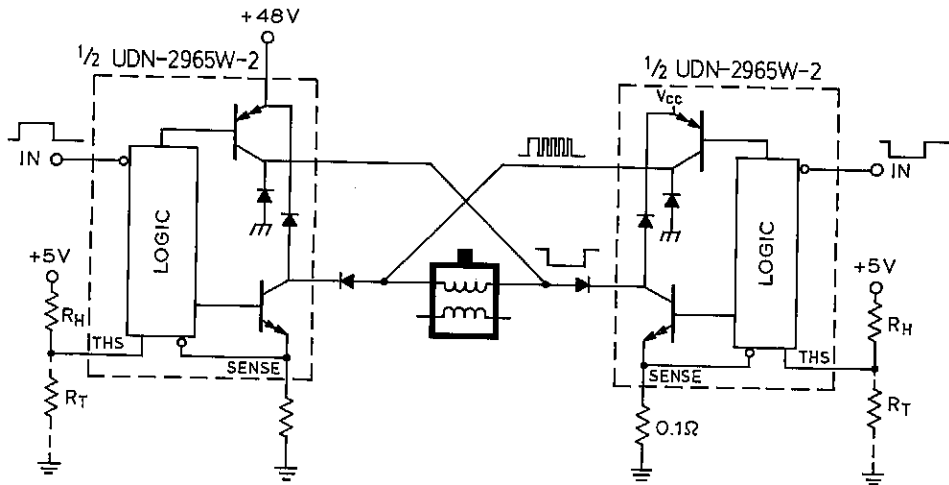

R_H AND R_T DETERMINE HYSTERESIS AND PEAK CURRENT

Dwg. No. B-1538

UDN-2993B DUAL FULL-BRIDGE MOTOR DRIVER

THE UDN-2993B MOTOR DRIVER contains two independent H-bridges capable of operating with load currents of up to 600 mA. An internally generated deadtime prevents potentially destructive crossover currents when changing load phase. Internal transient-suppression diodes are included for use with inductive loads. Emitter outputs allow for current sensing in pulse-width modulated applications.

RECOMMENDED MAX. OPERATING CONDITIONS

Load Voltage Range, V_{BB}	10 V to 40 V
Output Current, I_{OUT}	± 500 mA
Logic Voltage Range, V_{DD}	4.5 V to 5.5 V

2-PHASE BIPOLAR STEPPER-MOTOR DRIVE (Pulse-Width Modulated)

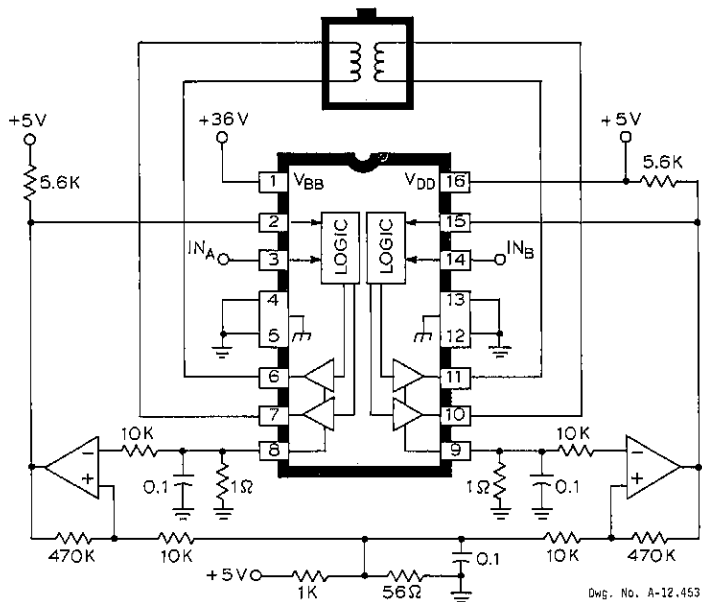

Dwg. No. A-12,453

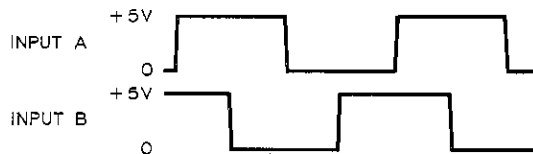

Dwg. No. A-12,454

**UCN-5800A, UCN-5801A, UCN-5813B, AND UCN-5814B
UNIPOLAR MOTOR DRIVERS**

DRIVING UNIPOLAR motors is one of many successful applications for the UCN-5800A, UCN-5801A, UCN-5813B, and UCN-5814B BiMOS II latched sink drivers. Selected devices, for higher voltage operation, are available as the UCN-5813B-1 and UCN-5814B-1.

All devices contain CMOS data latches, CMOS control circuitry, high-voltage, high-current bipolar Darlingtons outputs, and output transient protection diodes for use with inductive loads.

The UCN-5800A is a direct replacement for the original UCN-4401A. The UCN-5801A replaces the UCN-4801A. With a 5 V supply, BiMOS II devices typically operate at data input rates above 5 MHz; at 12 V, significantly higher speeds are obtainable. BiMOS III drivers, with output voltage ratings to 150 V, will be supplied as UCN-5900A and UCN-5901A.

Device	Package	Drivers	Features
UCN-5800A	14-pin DIP	4	Clear, Strobe, Output Enable
UCN-5801A	22-pin DIP	8	Clear, Strobe, Output Enable
UCN-5813B	16-pin DIP	4	Strobe and Output Enable
UCN-5813B-1			
UCN-5814B	22-pin DIP	4	Clear, Strobe, Output Enable, & Chip Select
UCN-5814B-1			

RECOMMENDED MAX. OPERATING CONDITIONS

Output Voltage, V_{OUT}	
UCN-5800A & UCN-5801A	35 V
UCN-5813B & UCN-5814B	35 V
UCN-5813B-1 & UCN-5814B-1	50 V
Continuous Output Current, I_{OUT}	
UCN-5800A & UCN-5801A	350 mA
UCN-5813B & UCN-5814B	1.0 A
UCN-5813B-1 & UCN-5814B-1	1.0 A
Logic Supply Voltage, V_{DD}	4.5 V to 12 V
Input Voltage, V_{IN}	V_{DD}

UNIPOLAR STEPPER-MOTOR DRIVE

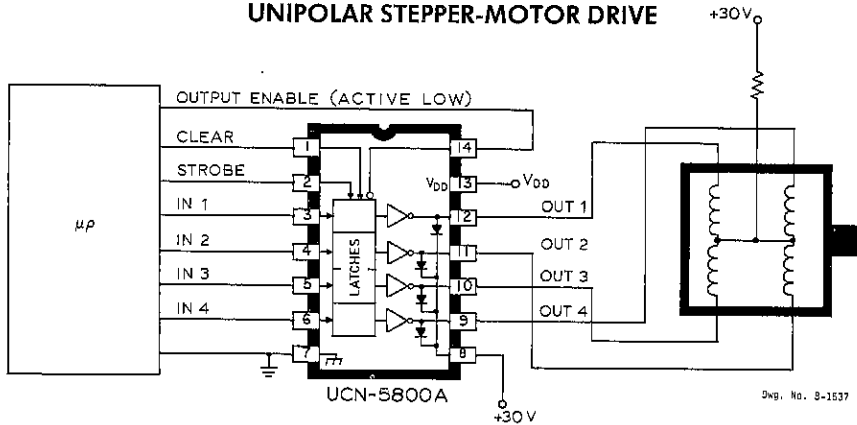

UNIPOLAR WAVE DRIVE

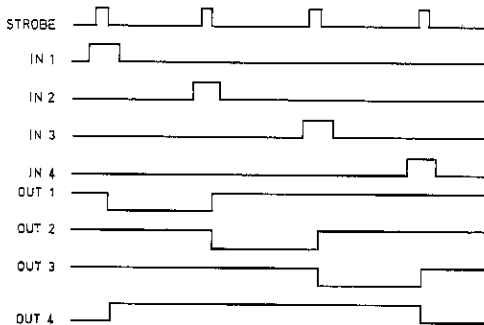

UNIPOLAR 2-PHASE DRIVE

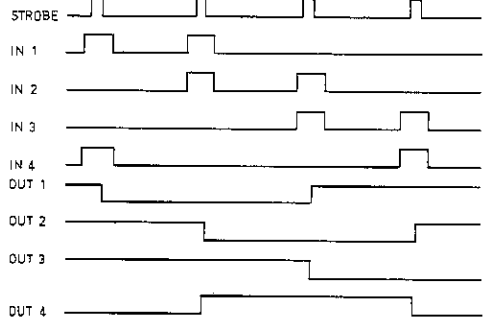

LINEAR MOTOR DRIVERS

POWER OPERATIONAL AMPLIFIERS are useful in driving voice-coil motors, linear servo motors, and ac and dc motors in a linear mode where motor speed or position is a direct function of a linear input signal. The operational amplifiers listed here are standard "building block" circuits providing almost unlimited application. The high-gain, high-impedance operational amplifier configuration allows many specialized input, output, and feedback arrangements.

All devices feature high output voltage swings, high input common mode range, high PSRR and CMRR. The unity-gain stable versions need no external compensation. Internal thermal shutdown circuitry protects these devices against output overloads. The dual amplifiers include programmable output current-sensing capability.

Part Number	Type	Max. ΔV_s	Cont. I_{out}	Peak I_{op}	Features	Package	Engineering Bulletin
ULN-3751Z	Single	28 V	± 2.5 A	± 3.5 A	Unity-Gain Stable Internal Compensation	5-Lead SIP	27118.1
ULN-3753W	Dual	40 V	± 2.5 A	± 3.5 A	Prog. Current Sense, External Compensation	12-Lead SIP	27118.10
ULN-3753B			± 1.0 A	± 3.5 A		16-Pin DIP	
ULN-3755W	Dual	40 V	± 2.5 A	± 3.5 A	Bootstrapped Output, Unity-Gain Stable, Prog. Current Sense	12-Lead SIP	27118.11
ULN-3755B			± 1.0 A	± 3.5 A		16-Pin DIP	

POSITION SERVO

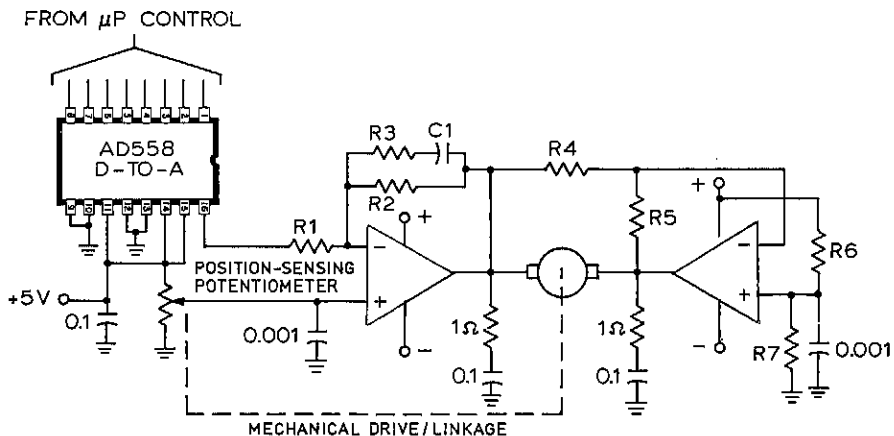

R4 = R5 = R6 = R7
 R1, R2 DEFINE D-C GAIN
 R3, C1 SELECTED FOR LOOP COMP.

Dwg. No. A-12,652

TWO-PHASE, 60 Hz OSCILLATOR/MOTOR DRIVER

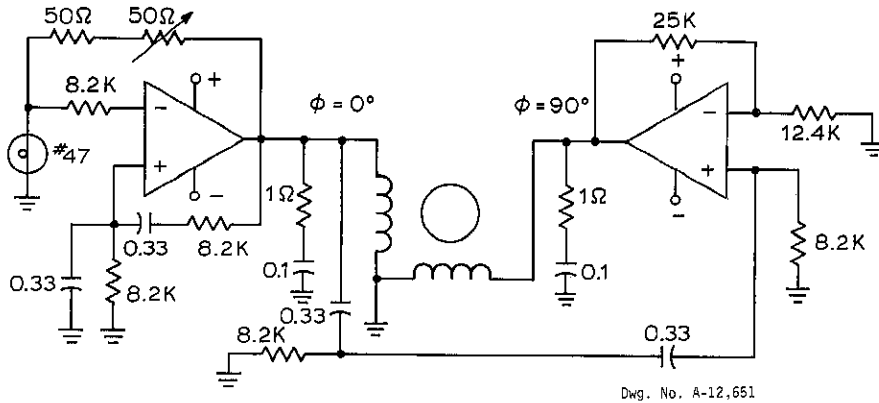

4

THREE-PHASE, 400 Hz OSCILLATOR/MOTOR DRIVER

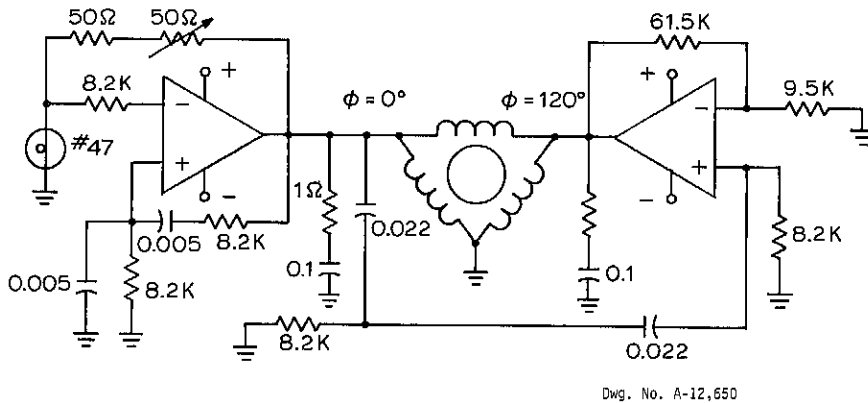

**ULN-2074B AND ULN-2075B
HIGH-CURRENT DARLINGTON SWITCHES**

THE ULN-2074B AND ULN-2075B high-current Darlington switches contain four isolated drivers. With appropriate input-level shifting, these devices can be used in emitter-follower (current-sourcing) applications.

The X-drive circuit shown below operates in the full-step mode with two phases ON in each position. X-drive is energy efficient and has better positional accuracy and hysteresis characteristics than conventional drive circuits.

RECOMMENDED MAX. OPERATING CONDITIONS

Motor Supply Voltage, V_{BB}	
ULN-2074B	35 V
ULN-2075B	50 V
Output Current, I_{OUT}	
ULN-2074B	1.25 A
ULN-2075B	1.5 A
Input Voltage, V_{IN}	
ULN-2074B	30 V
ULN-2075B	50 V

X-DRIVE MOTOR CONTROL

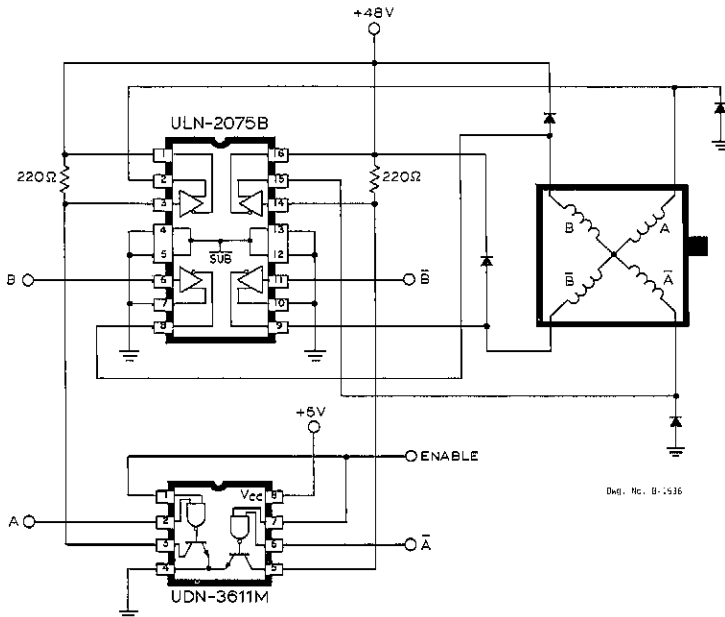

INPUT WAVEFORMS

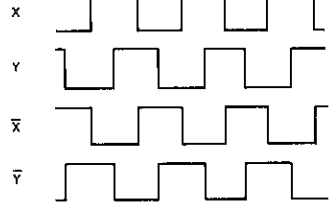

Dwg. No. A-11,795

Dwg. No. B-1936

UDN-2941B QUAD HIGH-CURRENT SOURCE DRIVER

THE UDN-2941B high-current source driver has four independent emitter-follower drivers, associated input-level shifting, and output transient-suppression diodes. Special circuit design techniques result in reduced output-saturation voltages, and improved output-switching speeds. These two characteristics allow the UDN-2941B driver to operate high-current inductive loads at maximum efficiency.

Where increased package power dissipation ratings are required, the modified bat-wing "B" package with a copper lead frame allows the attachment of an inexpensive heat sink. The heat sink is at ground potential and needs no insulation.

RECOMMENDED MAX. OPERATING CONDITIONS

Motor Supply Voltage, V_{BB}	12 V to 30 V
Continuous Load Current, I_{OUT}	
UDN-2941B	- 1.5 A
ULN-2068B	1.25 A
ULN-2069B	1.5 A
Input Voltage, V_{IN}	12 V

4

FULL-BRIDGE MOTOR DRIVER (One of Two Windings Shown)

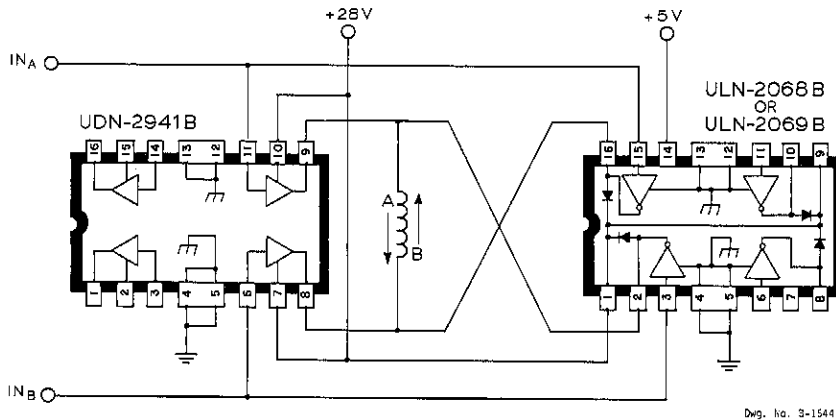

BIPOLAR STEPPER-MOTOR DRIVE

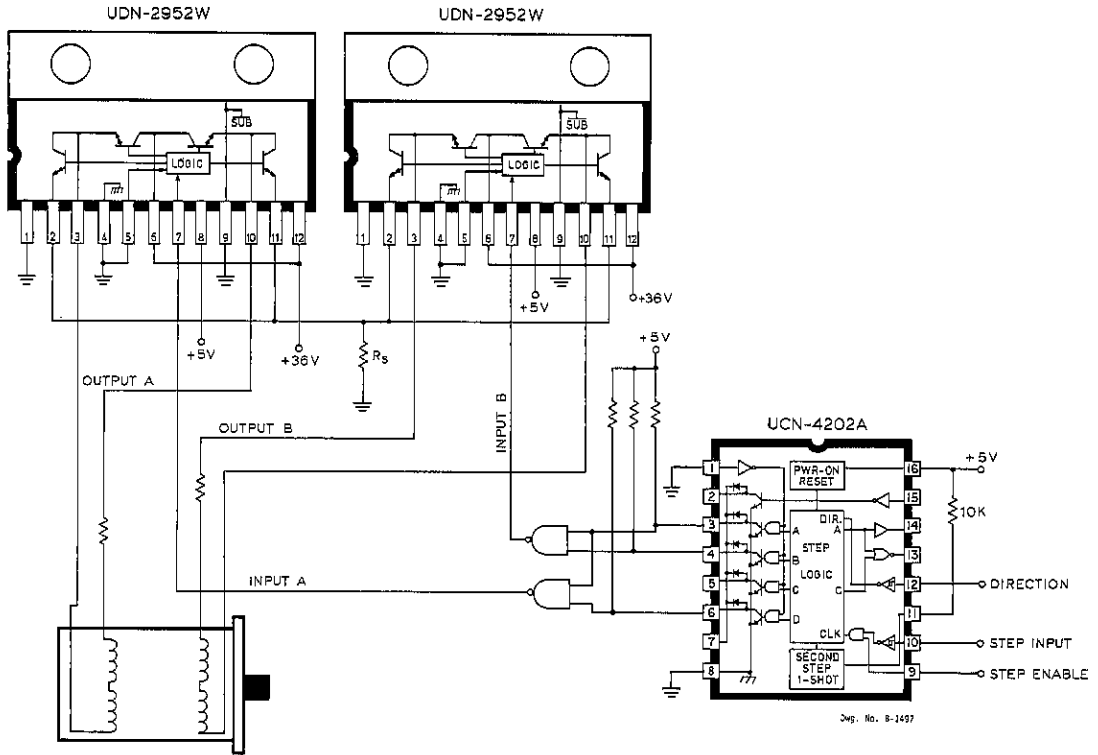

4

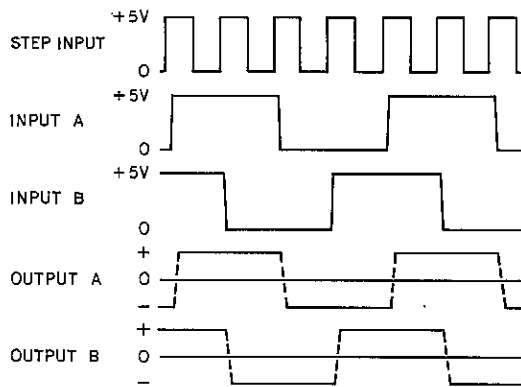

NOTES:

1. This is *not* a bipolar, pulse-width modulated application.
2. Resistor R_s sets the maximum allowable output current for protection against crossover currents and short circuits. $R_s = 0.6/I_{LIMIT}$.

**UDN-2935Z AND UDN-2950Z
HIGH-CURRENT BIPOLAR HALF-BRIDGE MOTOR DRIVERS**

THE UDN-2935Z AND UDN-2950Z ICs are monolithic half-bridge motor drivers in power tab TO-220 style packages. The circuits combine sink and source drivers with diode protection, gain and level shifting systems, and a voltage regulator for single-supply operation. They are designed for servo-motor drive applications using pulse-width modulation.

The PWM drive mode is characterized by minimal power dissipation requirements and allows the output to switch currents of 2 amperes. Output d-c current accuracies of better than 10% at 100 kHz can be obtained.

The UDN-2935Z and UDN-2950Z may be used in pairs (full-bridge) to drive d-c stepper motors or brushless d-c motors.

Either power driver may also be used in stepper motor bipolar bridge circuits as, for example, with the Sprague UCN-4202A or UCN-4204B stepper motor translator/drivers.

RECOMMENDED MAX. OPERATING CONDITIONS

Supply Voltage, V_S	8.0 V to 35 V
Continuous Output Current, I_{OUT}	± 2.0 A
Peak Output Current, I_{OP}	± 3.5 A
Input Voltage, V_{IN}	5.5 V

SINGLE-WINDING DC OR STEPPER-MOTOR DRIVE

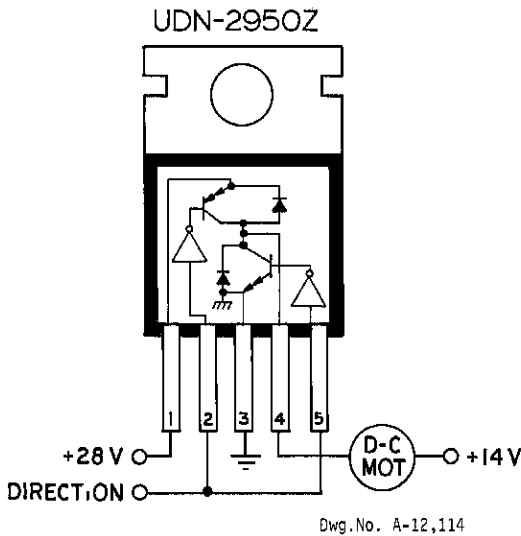

FULL-BRIDGE DC SERVO-MOTOR DRIVE

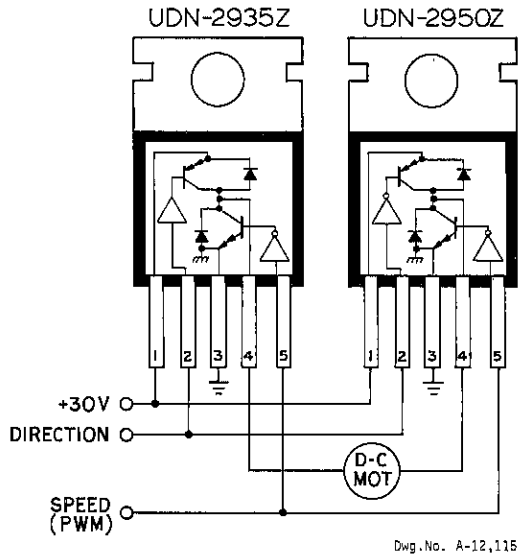

**3-PHASE BRUSHLESS DC MOTOR CONTROL
(Using Sprague Hall Effect Sensors)**

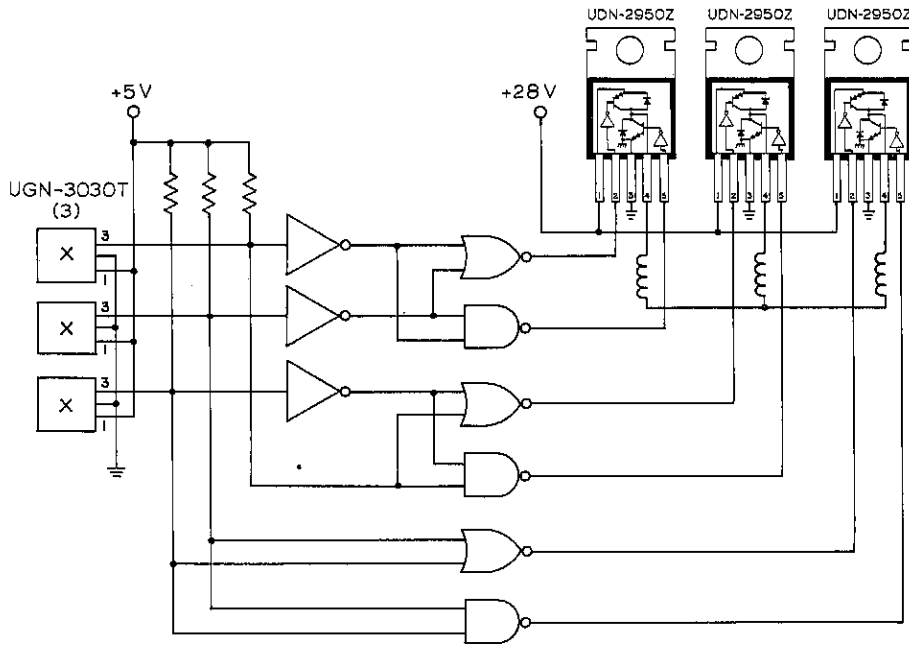

Dwg. No. A-12,653

4

**UDN-2933B AND UDN-2934B
3-CHANNEL HALF-BRIDGE MOTOR DRIVERS**

THE UDN-2933B AND UDN-2934B integrated circuits are specifically designed for three-phase, bipolar brushless d-c motor applications. Saturated drivers provide for low output-voltage drops at maximum rated current. The two devices differ only in input logic levels: The UDN-2933B is for use with TTL and 5 V CMOS. The UDN-2934B is intended for use with 12 V CMOS. Both devices have a common ENABLE function, independent inputs, internal

transient suppression, and tri-state outputs allowing them to be used in diverse applications.

RECOMMENDED MAX. OPERATING CONDITIONS

Motor Supply Voltage Range, V_{BS}	10 V to 30 V
Output Current, I_{OUT}	± 800 mA
Logic Supply Voltage Range, V_{CC}	
UDN-2933B	4.5 V to 5.5 V
UDN-2934B	10 V to 13.5 V

3-PHASE BRUSHLESS DC MOTOR DRIVE

Driver Inputs						Motor Current	Electrical Degrees
1	2	3	4	5	6		
Low	High	High	Low	High	Low	AB	0
Low	High	High	Low	Low	High	-CA	60
High	Low	High	Low	Low	High	BC	120
High	Low	High	High	Low	Low	-AB	180
High	High	Low	High	Low	Low	CA	240
High	High	Low	Low	High	Low	-BC	300

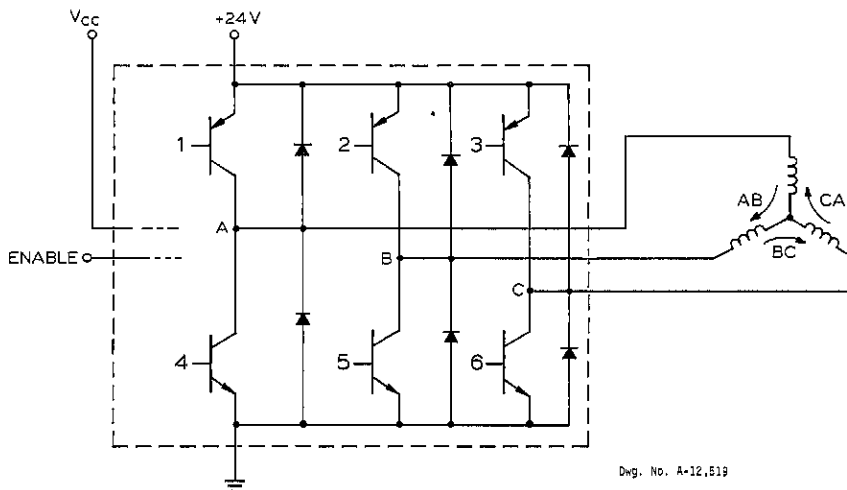

SWITCHING INDUCTIVE LOADS WITH POWER INTERFACE ICs

Integrated circuits that carry both logic and bipolar power devices — whether for driving print hammers, servos, steppers, relays, or brushless dc motors — are going a long way toward consolidating industrial-control electronics. Though these power interface ICs greatly simplify the system designer's task, they must be implemented carefully when they operate an inductive load.

To do so, the engineer must fully understand how the device's fundamental specifications relate to that inductive load, ensuring that the chip's breakdown limits are never exceeded. For example, the designer must be able to distinguish between the vaguely similar but quite different output-voltage specifications and know how to clamp transients since they cannot be prevented. The limitations and idiosyncrasies of ever-present parasitic elements also need to be well understood if the device is to operate flawlessly.

The biggest roadblocks to successful circuit design are two frequently misunderstood specifications. The first is the power interface chip's maximum output voltage, V_{CEX} . In most cases, this parameter approximates $V_{BR(CBO)}$, the minimum collector-base breakdown voltage with the emitter lead open. The actual designation would be $V_{BR(CEX)}$, which denotes that there is a standard resistance in the emitter lead. It should not be exceeded at any time, especially if the load is inductive.

The maximum collector-base breakdown value for a given IC is confirmed by applying a voltage to the device's output to measure its maximum

leakage current, which is specified in the data sheet. Operating any load above the voltage that may produce the maximum leakage current is thus unsafe. Even with resistive loads, the user may encounter occasional trouble if the load line is steep. Trouble occurs because the line may cross the point equal to the minimum collector-emitter sustaining voltage.

The second fundamental specification, $V_{CE(sus)}$, is the greatest voltage that the chip can sustain under worst-case conditions. This limit is determined by the minimum collector-emitter voltage

4

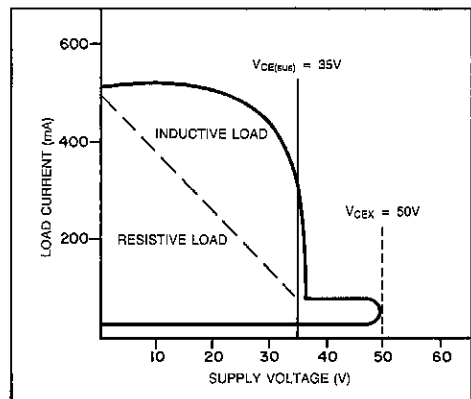

DWG. NO. A-13,009

1. The limits of power interface chips are more likely to be exceeded when operating inductive loads due to the reactive voltages generated by switching. Also, the collector-emitter potential may be above the supply voltage. Thus designs must ensure the dc operating voltage stays below the device's minimum sustaining voltage, $V_{CE(sus)}$, for a given quiescent load current. In no case should its maximum output voltage, V_{CEX} , be exceeded.

Reprinted by permission from the March 14, 1985 issue of Electronic Design, Copyright © 1985 by Hayden Publishing Co., Inc., Hasbrouck Heights, NJ.

HIGH-CURRENT INTERFACE DRIVERS

for a specified output current. It can also be measured with a coil dump test, in which the IC's output is switched off and its output voltage measured. Generally, the first test is done at 5% to 10% of the nominal output current for a given application. The coil test is often run at a high output current and for a specified inductance. Either of these conditions will satisfactorily confirm a device's minimum output-sustaining voltage.

Switching inductive loads with interface ICs, then, demands careful attention to both the device's load line and the guaranteed output-sustaining voltage. With inductive loads, reactive voltages often greatly exceed the source voltages when the chip is switched off (Fig. 1). The source voltage is clamped off to a safe value with flyback diodes that are effectively shunted across the inductive load and are often internal to the device. Without such protection, or that offered by resistor-capacitor snubbing networks, the high voltage that results from switching the coil will likely damage or destroy the device. Unfortunately, internal protection alone is often insufficient, and external clamping circuitry must be added.

Of great concern to the designer is that insufficient output protection may result in gradual — and thus hard to detect — secondary breakdown. Particularly hardy power interface chips may seem to stand up well to occasional transients in excess of 100 V for a load supply voltage of 12 V; that is, until they suddenly fail.

When fast switching is a must, it is generally only achieved with a circuit that allows the output voltage to rise fast and exceed the supply voltage. For such approaches, other schemes must be used. Typically, both external Zener diodes and resistors should be employed. Together, they furnish inexpensive protection. Zener diodes, however, are often used alone.

DROPPING THE RESISTOR

The reason for this apparent omission is obvious once it is realized that the flyback voltage is not only a function of current and resistance but also of the number of outputs switching off at any time. Only well-defined or simultaneous switching sequences are suitable for resistors; without either, the magnitude of the voltage transient produced

is difficult to determine. Some industrial timing circuits may be both low-speed and predictable; unfortunately, random switching is the rule rather than the exception.

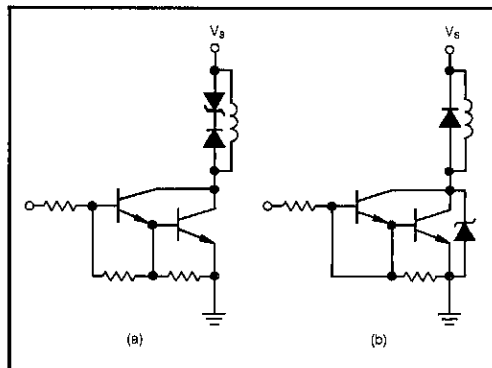

DWG. NO. A-13,007

2. Arranging a Zener diode network in series to clamp a power interface chip's output allows its flyback voltage to rise above the supply voltage, enabling the device to be turned off faster (a). When poorly regulated supply voltages power a circuit that drives multiple devices whose voltage transients exceed the chip's capability, a parallel configuration is preferred (b).

Zener diodes, on the other hand, do not suffer from that limitation. The voltage rating for a series arrangement (Fig. 2a) is determined by:

$$V_Z = V_{CE(sus)} - V_{SUPPLY} - V_F$$

where V_F is the diode's forward voltage drop. Thus for an IC with a sustaining voltage of 35 V, a 15 V supply, and a diode drop of 2 V, the maximum Zener value is 18 V. For designs that use many power ICs for multiple loads, it is often practical to work with multiple Zener diodes with lower power and maximum current ratings. That avoids the cost of power devices and sidesteps their need for heat sinks.

Zener diodes can be placed in parallel across the output as well (Fig. 2b). In this case, the Zener voltage must be slightly below the minimum sustaining voltage. Automotive systems, for one, typically employ internal 30 V to 35 V clamps in their interface chips because such operations as "jump starting" two or three 12 V batteries precludes the series approach. A setup exhibiting an unregulated supply voltage, which varies con-

siderably, may also necessitate the parallel clamping approach.

Beyond staying within the chip's maximum voltage rating, the designer's second major concern is avoiding problems created by inherent parasitic elements. In the early days of the TTL device and its gold-doped low-resistivity silicon, parasitic problems were virtually non-existent. (Adding gold to improve circuit speed effectively killed parasitic elements.) Linear bipolar ICs and a wider range of power loads make parasitic concerns much more of an issue. The vast majority of today's chips are junction-isolated ICs and they all demonstrate such unwanted by-products inherent in their fabrication processes.

The most common parasites pertaining to inductive loads are the vertical PNP and lateral NPN transistors that are created by a device's protection circuitry. The internal flyback diode of a power interface chip, for instance, becomes a low-gain transistor (Fig. 3).

Most circuits are not affected by this parasitic transistor, unless the switching frequency is above the audio range. Curiously enough, many of the problems are related to power dissipation. The parasitic transistor often draws considerable power, thus raising the chip's temperature, even when the transistor's gain is below unity.

MINIMIZING THE PROBLEM

Where practical, lowering the supply voltage and decreasing the pulse repetition rate will minimize the trouble. When high switching rates and maximum source voltages are necessary, the best technique is to place a discrete diode across the device's output stage, between collector and the supply line (or to ground if Zener clamping is used). A discrete diode, with its lower forward-voltage drop, effectively shunts the flyback diode and will conduct most of the current during clamping.

Less troublesome, but still of concern, are the lateral parasitics that may cause circuit anomalies and malfunctions. In many stepper motors particularly, the transformer action of the motor windings produces undesirable substrate currents into the IC. In effect, a negative voltage is applied at the device's output, and current is injected into its substrate.

The problem is exacerbated by the IC's junction isolation, which produces a parasitic transistor across the isolation diodes (the transistor's base lead is connected at their junction). Frequently, current injected into the device's output is sufficient to create formidable substrate currents, thus turning all lateral transistors on.

As a result, the device's leakage current may increase, and the chip may be inadvertently activated. In extreme cases, positive feedback causes the IC to destroy itself. Circuits employing small low-current stepper motors are not generally a problem, since the substrate current is seldom sufficient to turn on the transistor. In high-current applications, however, putting a discrete diode across the output device's collector-ground junction will cure the problem.

A parasitic diode exists at the input circuit to most power interface chips. In many instances, it may hinder circuit operation when a negative voltage is applied to the input, since substrate currents may be created. Connecting a discrete back-biased diode directly between input and ground diverts current away from the substrate. Provisions should be made, though, for limiting the current if the input state is to be pulled to voltages well below ground.

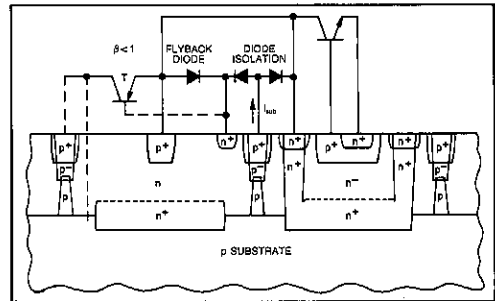

DWG. NO. A-13,008

3. The interface IC's flyback diode almost always creates a parasitic transistor (T) at the device's output. Further, substrate currents form a transistor across the diodes that isolate various junctions of the chip. Moreover, parasitic diodes at the inputs also are common. Adding external protection diodes at both the input and output eliminates many undesired circuit operations such as false triggering. Further, it may well prevent the device from being destroyed by the positive feedback currents that are occasionally generated.

TURNING IT OVER

Employing power interface ICs to drive motors demands adherence to four basic design rules. First, if the device is without internal protection, diodes must be added to clamp both positive and negative overshoots caused by inductive loads. Second, if the device is protected with internal clamps, external diodes could be added. That not only serves as insurance but eliminates the effects of parasitic elements, which occasionally trigger or even destroy the chip. Third, in balanced drive arrangements, complementary input signals should be appropriately skewed. Doing so avoids crossover currents that may cause excessive heating and reduce available output current. Finally, when it is unclear if the interface chip furnishes suitable drive to the motor — or if it is difficult to damp the effects of parasitics at high outputs — discrete bipolar transistors and appropriate clamping may be the solution. The transistors driven by the chip, in turn power the motor.

Consider a dc motor circuit driven by a 1.5 A quad Darlington device that uses four discrete diodes for protection and commutation (Fig. 4a). The configuration, which employs a so-called

bipolar, or bridge arrangement, allows the motor to turn either clockwise or counterclockwise.

HALF-BRIDGE OPERATION

Alternatively, the half-bridge motor driver run by a pair of chips also makes possible bipolar operation (Fig. 4b). Further, speed is controlled by a pulse-width-modulated waveform. Clamping diodes on either side of the motor take care of the problems caused when the motor changes direction. And with minimal modification, the driving circuitry accommodates ac motors as well. More specifically, no clamping diode is required between pin 4 of each device and ground. The designer need only build circuitry to control the speed of the motor; no circuitry for defining its direction is required. As before, pins 2 and 5 of each device accept complementary driving signals.

Where intermediate, or discrete, bipolar transistors drive a dc motor, it is always best to install any clamping or commutating diodes close to the motor itself. Otherwise, inductive under-shoots or overshoots may find their way through the transistors, triggering or damaging them or the power interface chip.

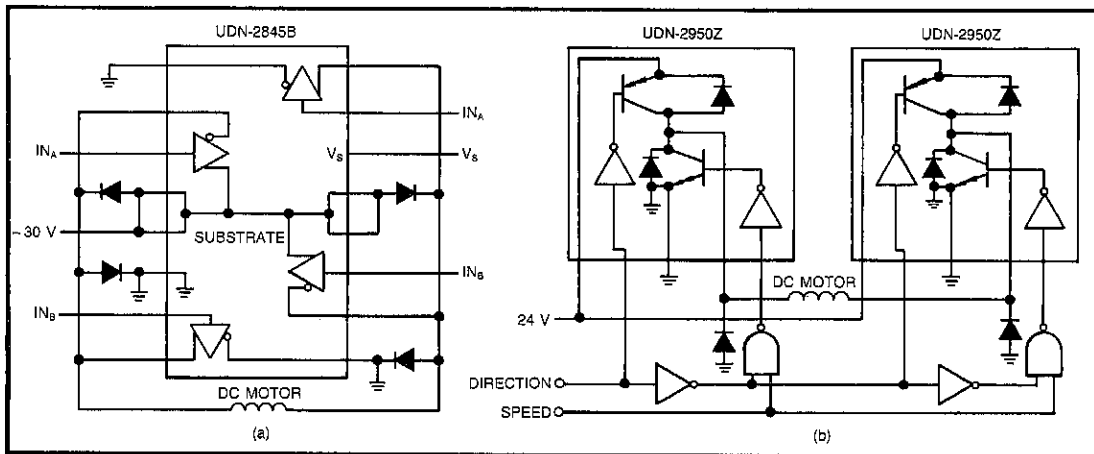

DWG. NO. A-13,006

4. Following simple clamping and driving rules ensures trouble-free operation. Four diodes protect and properly commute a chip that drives a two-way dc motor (a). Alternatively, two diodes protect a pulse-width modulated dc motor circuit from damage (b). In both cases, input signals should be appropriately skewed. When transistors are used as intermediate drivers, the clamping circuitry should be placed as closely to the motor as possible.

AN INTEGRATED 3-PHASE BRUSHLESS DC MOTOR DRIVER

Three-phase brushless dc motors are especially useful because they have no brushes to make noise, dust, or wear out. The brushes of a conventional motor have been replaced by position sensors, usually Hall effect or optical devices. These sensors detect the rotor position with respect to the stator windings. This information is used to drive the windings in a sequence synchronized with the rotor position, called commutation. To use a three-phase brushless motor usually requires custom ICs to perform the commutation, and discretized drivers. Then, to control the motor current, and with it speed and torque, requires pulse width modulation circuitry. All this adds up to many components and an expensive solution.

Now, due to progress in integrated power technology, all of the functions needed to drive three phase brushless motors can be performed by one chip. The UDN-2936W incorporates Hall effect sensor decoding logic, power outputs capable of driving 2 A continuous at 50 V, PWM current limiting, direction control, dynamic braking, and integrated protection features. This device can be used to provide a simple, inexpensive, and reliable solution to the problem of driving brushless dc motors.

Overall Chip Structure

The UDN-2936W is made up of five sections, namely the commutation logic, output drivers, current limiting, direction and braking, and thermal shutdown. All logic and power functions utilize only bipolar processing, which allows for high power with an efficient use of die area.

Motor Commutation

In a three-phase motor, winding current must be synchronized to rotor position to run the motor efficiently, i.e., with unidirectional torque. Hall effect

sensors detect rotor position, which must be decoded to drive the coils in the proper sequence. Hall effect sensors produce low level differential analog outputs. Today's Hall effect ICs amplify this signal 86 make it easier to use. These Hall effect ICs produce either large signal ac linear waveforms, or open collector digital signals. The UDN-2936W is compatible with both types of Hall effect IC (pull-up resistors are needed for open collector digital Hall effect ICs).

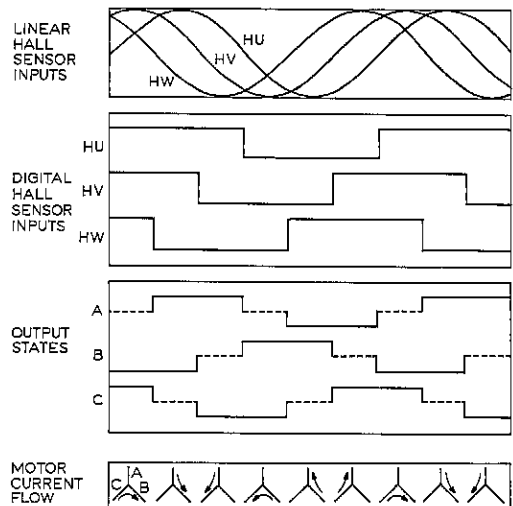

Dwg. No. A-14,148

Figure 1

Position of the Hall effect sensors determines the decoding sequence to produce the correct driving waveforms for each motor. The decoding sequence programmed into this device is based on Hall effect cells 60 electrical degrees apart. This 60 degree se-

4

HIGH-CURRENT INTERFACE DRIVERS

quence is one of the most common used in the industry. The truth table and timing waveforms found in Figure 1 illustrate how the Hall cell inputs, driving output waveforms, and motor currents states are interrelated. Motors with other commutation sequences can typically be accommodated by inverting one of the position inputs.

Chopping Current Control

The current limit technique chops the source drivers to control the load current level. The maximum current and percentage ripple, or hysteresis, can be programmed by the user or left to internal default values. Source chopping produces a continuous sense voltage (see Figure 2), so this voltage is an accurate representation of load current, even during recirculation. Also, chopping only the sources produces a fast current charge-up and a slower current decay. This occurs because of the different voltages across the coil in both states, and results in a controllable current waveform. The chopping method functions as follows: When the current reaches I_{lim} , the source is disabled and the current recirculates through a sink driver and clamp diode. The motor current decays a fixed percentage, the source is enabled again, and the cycle repeats. The internal sense voltage comparator has a limited bandwidth that essentially filters out noise on the sense pin to prevent erroneous chopping.

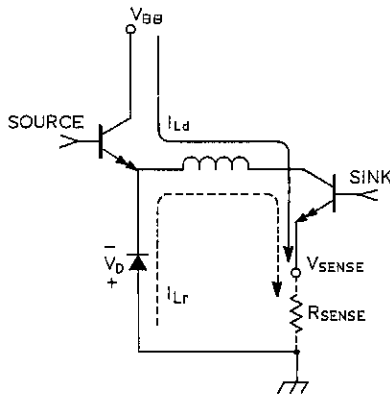

Figure 2

The limiting current level and hysteresis are determined by the user or left to internal defaults. Figure 3 illustrates these values in a typical output current waveform. A voltage divider on the V_{ref} pin sets the external V_{ref} . If set above 2.5 V, the internal V_{ref} is used. Whether V_{ref} is set internally or externally,

$V_{ref}/10$ is the limiting threshold on V_{sense} . The default limiting can be programmed by:

$$I_{lim} = \frac{.25 V}{R_{sense}}$$

Default hysteresis is set at 7.5%. For a $V_{ref} < 2.5$ V, the limiting threshold is the following:

$$I_{lim} = \frac{V_{ref}}{10 * R_{sense}}$$

In this case, hysteresis is created by drawing 200 μ A from the resistor divider when the sources are chopped, lowering the limiting threshold a certain percentage. The sources turn back on when the sense voltage decays to the new lower threshold. Hysteresis is given by this expression:

$$\%hys = \frac{100 * (200 \mu A * R2)}{V_{pk}}$$

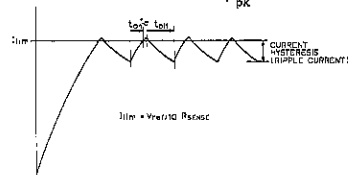

Dwg. No. A-14,148

Figure 3A

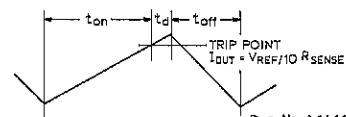

Dwg. No. A-14,149

Figure 3B

The hysteresis current source, V_{ref} voltage divider, and current limiting equations can be found in Figure 4. The tables in Figure 5 aid in selecting values for $R1$ and $R2$.

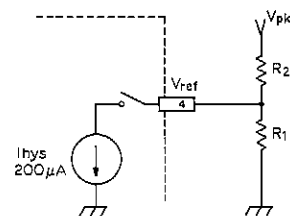

Dwg. No. A-14,150

Figure 4

The internal and external current limit settings can be used together to start a motor with a high regulated current, and run it at a lower regulated current. To do this, V_{ref} must be tied above 2.5 V when the motor starts, and the V_{ref} divider switched in after start-up (see Figure 6).

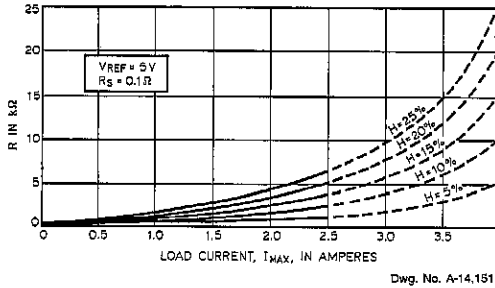

Dwg. No. A-14,151

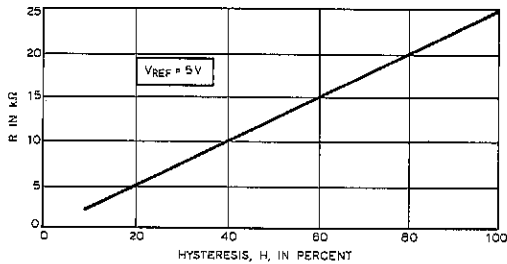

Dwg. No. A-14,152

Figure 5

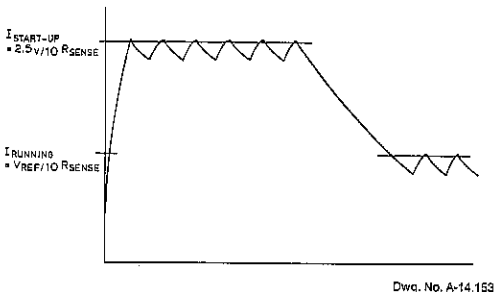

Dwg. No. A-14,153

Figure 6

Outputs

The output section consists of three half-bridges capable of sourcing or sinking 2 A continuously at a saturation voltage of less than 2 V per driver. They are built to sustain at least 50 V. Source and sink clamp diodes are included to provide a current path during commutation and chopping. These are high-

performance substrate isolated diodes that virtually eliminate the wasteful parasitic substrate currents of conventional diodes. The drivers, both source and sink, are bipolar double level metal Darlingtons.

Direction and Braking

The direction control allows the motor to be reversed even while running. When direction changes polarity, the state of the outputs is reversed, i.e., if the source was ON, the sink will turn ON, and vice versa. Because the turn off times are longer than the turn on times, the drivers turning ON must be delayed by a precise amount to prevent potentially destructive crossover currents. This delay is generated internally.

The brake function uses the back EMF of the motor to brake it dynamically. The windings are effectively "shorted" together through sink drivers and clamp diodes.

Thermal Shutdown and Power Dissipation

The thermal shutdown feature protects the IC from overheating. This circuit turns OFF all drivers at about 165° C, and allows the device to cool down approximately 25° before turning ON again.

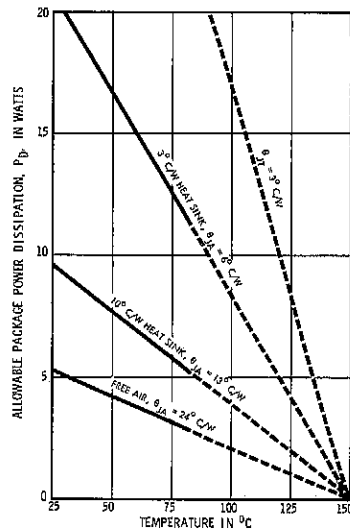
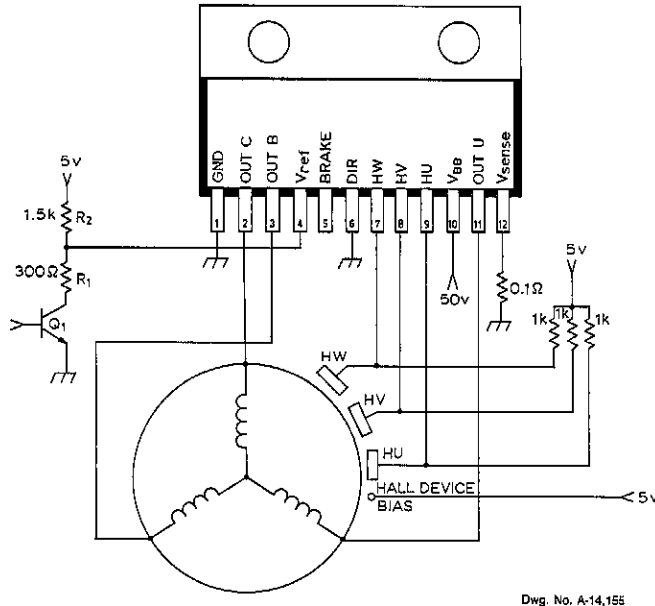

Figure 7



Dwg. No. A-14,155

Figure 8

The device is packaged in a 12 pin power SIP that has a large copper tab for excellent heat dissipation. The design of the tab, and the fact that it is at ground, make the package easy to use with a heat sink. The maximum allowable power dissipation in 25°C ambient air without a heat sink is 5.2 W. With minimal heat sinking, dissipation greater than 10 W can be accomplished. See Figure 7 for more information on power ratings.

Application

The application shown in Figure 8 is a simple one illustrating the use of the UDN-2936W in an open loop situation with bi-level current limiting. The motor uses digital open collector Hall cells such as the Sprague UGN-3013T, so pull-up resistors are required. Three 1 kΩ resistors pull up the Hall IC outputs to a 5 V supply, the same one needed to power the Hall effect ICs themselves. If the motor is equipped with linear Hall effect ICs, such as the Sprague UGN-3503U, then there is no need for pull-up resistors on the inputs. These Hall effect sensors have a quiescent output voltage of 2.5 V, and emitter follower outputs. The UDN-2936W has a regulated internal 2.5 V reference designed to make the inputs compatible with those linear Hall effect sensors. The 5 V supply is also used as a reference in the current

limiting for the V_{ref} resistor divider. Choosing $R_{sense} = 0.1$ ohm results in internal default limiting current of 2.5 A, and 7.5% ripple. This internal limiting is active when Q1 is off. R1 and R2 form a resistor divider, when Q1 is on, to apply 1 V to the V_{ref} input, producing 1 A of regulated running current and 5% ripple. Typically, Q1 would be off during start-up, giving 2.5 A of regulated start-up current, and then turned on to provide 1 A of running current. The values of R1, R2, and V_{sense} can be calculated using the circuit and equations of Figure 5, or the tables of Figure 6.

The motor speed is controlled by the current limiting. For a given load, speed is proportional to torque, and torque is proportional to motor current. Subsequently, the motor speed can be controlled through V_{ref} .

Conclusion

Smart power integrated circuits have come a long way in the past few years in solving numerous motor driving problems. The UDN-2936W is one example of how integrated monolithic devices can replace a drive circuit of many components with one reliable component. Also evident is the fact that bipolar transistors continue to provide economic solutions in the high current application.

POWER OP AMP APPLICATIONS

Sprague monolithic power operational amplifiers meet many high-current design challenges. The Series ULN-3750 high-gain, high-current operational amplifiers are used in power-driver applications such as servo-positioning systems (e.g., voice-coil motors for disk drives), dc motors, single-phase and multiphase motor-drive circuits, linear regulators, and in many other applications that, in the past, have required power buffers driven by conventional operational amplifiers.

Linear motor drivers will inherently produce lower electrical noise levels than their fast-switching digital counterparts. Linear position servos usually achieve substantially higher resolution and are capable of faster response than digitally controlled stepper motors. Series ULN-3750 offers increased output-voltage swing and high output-current drive, high gain as well as unity-gain stability and the capability

to sense load currents without need of the usual level-shifting or sense circuitry.

The operational amplifiers in this family of ICs provide peak push-pull output currents as high as ± 3.5 A, making them suitable for applications in which both current sourcing and current sinking are needed. As illustrated in the examples that follow, some of the op amps allow a very high output swing. They also provide overload and thermal protection under a variety of fault conditions.

Attention to thermal design in IC layout has minimized temperature-induced degradation of parameters while maximizing output-power capability. Single power op amp drivers are furnished in power-tab TO-220 packages (ULN-3751Z). Dual units are supplied in 12-pin single in-line packages (ULN-3753W and ULN-3755W) and in low-cost standard DIPs with heat-sink tabs (Series ULN-3750B).

4

SERIES ULN-3750 POWER OP AMPS

Device	Type	Peak Current Output	Short-Circuit Protection	Thermal Protect	Boost Voltage	Compensation	Functional Supply Span	Package
ULN-3751Z	Single	3.5 A	—	Yes	—	Internal	6V to 30V	5-Pin TO-220 Power-Tab SIP
ULN-3753W	Dual	3.5 A	Yes	Yes	—	External	6V to 40V	12-Pin Power-Tab SIP
ULN-3753B	Dual	3.5 A	Yes	Yes	—	External	6V to 40V	16-Pin Batwing DIP
ULN-3755W	Dual	3.5 A	Yes	Yes	Yes	Internal	6V to 40V	12-Pin Power-Tab SIP
ULN-3755B	Dual	3.5 A	Yes	Yes	Yes	Internal	6V to 40V	16-Pin Batwing DIP

Some of the material appearing in this application note, is taken from an article that appeared in the August 22, 1985 issue of EDN magazine

BRUTE FORCE AND SMALL SIGNALS

Both classical small-signal op amps and brute-force boosters must possess two attributes: they must have true differential (inverting and noninverting) inputs. Second, to minimize errors and drifts in closed-loop configurations, they must have high open-loop gain. Frosting-on-the-cake includes low offset voltage and drift, unity-gain stability, high output swing, large common-mode input range, high common-mode rejection, short-circuit protection, and a thermal-shutdown feature.

Sprague Series ULN-3750 offers all these features, and more. Consider the input section. The circuit is a classic op amp input stage found, for example, in many operational amplifiers with little power-handling capacity. The use of PNP input transistors allows the application of input voltages ranging from about 0.5 V below ground to approximately three base-emitter drops below the positive supply voltage. The ability to use ground-level input voltages is an important consideration. It allows the op amp to be easily operated from a single supply, where the input source is often referenced to ground.

The two capacitors shown in the input-circuit

schematic provide compensation with adequate phase-gain margins to allow operation for closed-loop gains as low as 1. Note the graph of the amplifier's gain and phase characteristics as functions of frequency (noninverting test circuit, $A_v = 1000$). It exhibits a smooth, 6 dB per octave rolloff to frequencies as high as 1 MHz, and an approximate 20° phase margin at unity gain.

In the amplifier's output stage, the output transistors are completely protected from inductive kickback voltages by clamping diodes built into the chip. The clamp diodes are capable of handling currents equal to the rated capacity of the output sink/source transistors. The output transistors are connected in a quasi-complementary configuration. The lower sink transistor can provide output voltages as low as ground plus one saturation drop. The current-sense terminals can be used to impart a transconductance characteristic to the amplifier, or simply to provide a separate power output ground and minimize output-to-input feedback through a common ground resistance.

INPUT STAGE

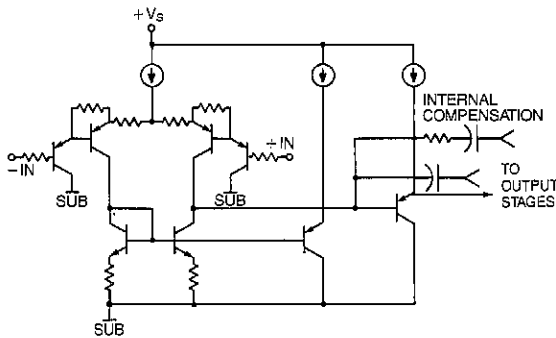

Dwg. No. W-115

GAIN AND PHASE CHARACTERISTICS

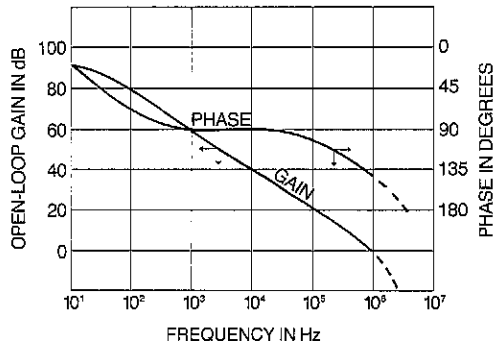

Dwg. No. W-116

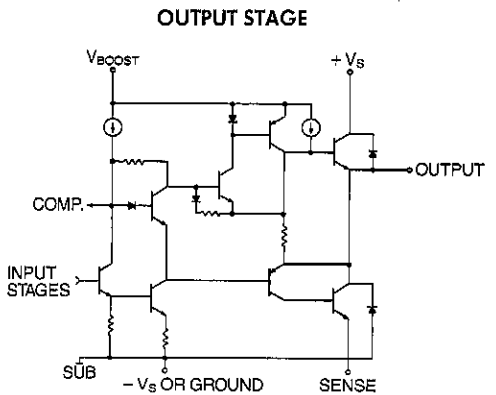

Dwg. No. W-117

BOOST TO BOOTSTRAP

The boost terminal is a unique feature of the ULN-3755B and ULN-3755W. It increases the amplifier's available output-voltage swing by 1 V to 2 V, depending on output current, by allowing the upper source transistor to saturate (an impossibility with the usual emitter-follower lacking the boost feature). To take advantage of the boost capability, use a boost-terminal voltage that is about 3 V higher than the positive load supply voltage. The boost function allows the amplifier

to be bootstrapped in ac applications by its own output or by another ac output.

The specifications shown below for the ULN-3755W apply to operation with ± 6 V supplies, at an ambient temperature of $+25^\circ\text{C}$. Not shown are the amplifier's absolute maximum ratings: 40 V supply span, ± 3.5 A peak repetitive current, and 20 W allowable package power dissipation (with $3^\circ\text{C}/\text{W}$ heat sink and $+25^\circ\text{C}$ ambient).

The Series ULN-3750 currently is comprised of six types. Considering allowable package power dissipation ratings, continuous output currents to ± 1 A are recommended for the 16-pin batwing DIPs (suffix "B"). Applications with ratings to ± 2.5 A require the TO-220 or 12-pin single in-line power tab packages (suffix "Z" and "W" respectively). All 5 types provide thermal shutdown at high junction temperatures. All are unity-gain stable. Pin count essentially dictates the features available with the various units. For example, the dual amplifiers lacking the boost capability (ULN-3753B/W) offer compensation pins for tailoring the operational amplifiers' frequency characteristics to specific applications. The single ULN-3751Z provides neither boost nor compensation options, due to the 5-pin limitation, but is unity-gain stable.



ULN-3755W DUAL POWER OP AMP

TYPICAL ELECTRICAL CHARACTERISTICS

Characteristic	Test Conditions*	Typical Value
Quiescent Current, $+I_s$ I_{BOOST}	No Load	70 mA
	$V_{\text{BOOST}} = 9$ V, No Load	7.0 mA
Input Offset Voltage	$V_{\text{OUT}} = 0$ V, No Load	2.0 mV
Input Bias Current	$V_{\text{OUT}} = 0$ V	80 nA
Input Offset Current	$V_{\text{OUT}} = 0$ V, No Load	10 nA
Open-Loop D-C Gain	$f = 0$ Hz	100 dB
Slew Rate	$V_{\text{IN}} = 0.2$ V Step	1.0 V/ μs
Output Swing	$V_{\text{BOOST}} = 6$ V, $I_{\text{OUT}} = \pm 1$ A	9.5 Vpp
	$V_{\text{BOOST}} = 9$ V, $I_{\text{OUT}} = \pm 1$ A	10.5 Vpp
Power-Supply Rejection	Either Supply	80 dB
Common-Mode Rejection		85 dB

* $T_A = +25^\circ\text{C}$, $T_{\text{HD}} \leq +70^\circ\text{C}$, $+V_s = V_{\text{BOOST}} = +6$ V, $-V_s = -6$ V (unless otherwise specified).

CAREFUL THERMAL DESIGN WRINGS WATTS FROM ICs

Power ICs are now capable of delivering tens of watts of power. It is easy to obtain such power from an IC when the device is mounted in a metal can with low thermal resistance. Moreover, it is easy to provide heat sinking for such a package. Metal packages, however, are expensive. The challenge is to develop inexpensive plastic packaging that also provides a way to keep junction temperatures at a safe level.

What's a safe level? At the moment, the prevailing industry standard for maximum junction temperature is $+150^{\circ}\text{C}$. However, using any temperature as a reference, an IC's expected lifetime roughly doubles for every 10°C reduction in junction temperature. Note, too, that such circuit parameters as leakage current suffer significant degradation at high temperatures.

The most widely accepted IC package is the dual in-line package (DIP). Without special enhancements, though, the standard DIP is woefully inefficient for thermal transfer. The package itself provides a junction-to-ambient thermal resistance as high as $125^{\circ}\text{C}/\text{W}$. This figure assumes the use of a Kovar lead frame and, since the lead frame is the main carrier of heat from the IC to the outside world, changing the material to copper reduces the thermal resistance to about $60^{\circ}\text{C}/\text{W}$. All Sprague power operational amplifiers have copper lead frames and heat sinks.

Limiting the junction temperature to $+150^{\circ}\text{C}$, the $60^{\circ}\text{C}/\text{W}$ figure allows a worst-case (still air) package power dissipation of 1.33 W at $+70^{\circ}\text{C}$. Unfortunately, this power figure is still inadequate for many modern power applications.

HIGH-POWER SIPs

For high-power applications, power ICs use single in-line packages similar to the TO-220, universally used for power transistors. The 5-pin ULN-3751Z uses such a package. Its maximum junction-to-tab thermal resistance is $4.0^{\circ}\text{C}/\text{W}$. The ULN-3755W dual power op amp is housed in a similar, but wider, package. Exhibiting $3^{\circ}\text{C}/\text{W}$ maximum junction-to-tab thermal resistance, the IC can dissipate as much as 26 W at a tab temperature of $+70^{\circ}\text{C}$.

ISOTHERMAL DESIGN CUTS GRADIENTS

Chip temperatures inevitably rise in high-power applications. Even with ideal packaging, the thermal resistance of the silicon chip itself will result in a temperature gradient across the chip. In linear circuits such as these op amps, the worst effects can arise from unequal heating on the chip's surface.

It is important to position input transistors as far as possible from the heat-generating output devices. What is less obvious is the need to arrange the high-

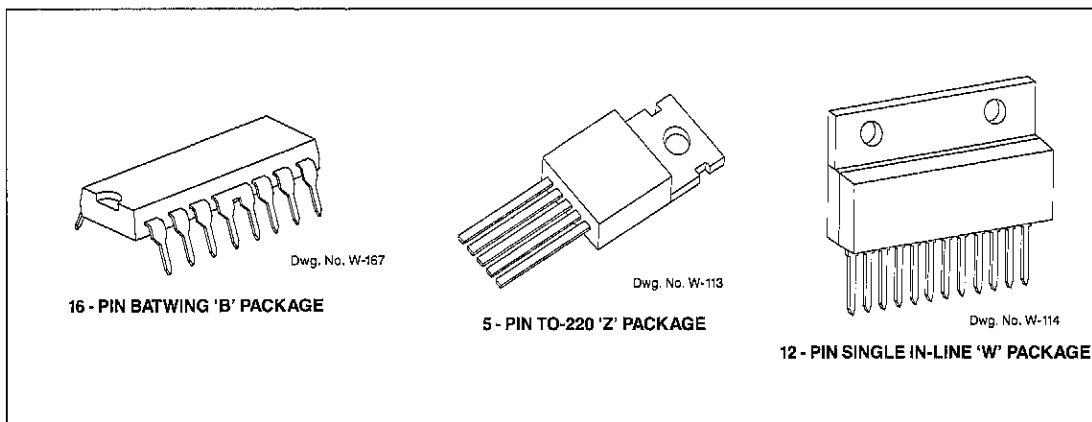

ISOTHERMAL DESIGN

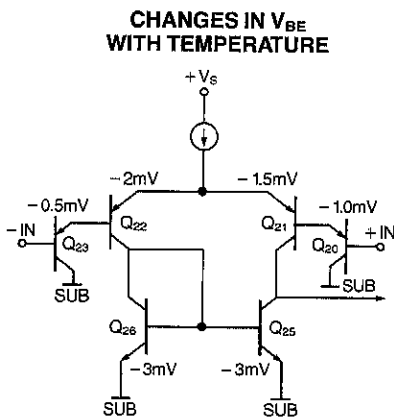

Dwg. No. W-118

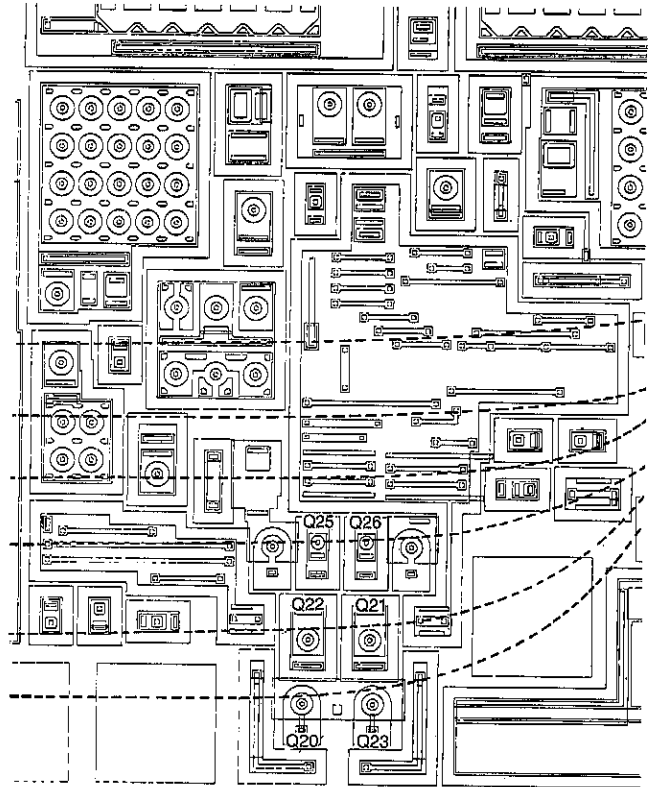

Dwg. No. W-168

4

gain input stages so as to minimize the effects of any temperature differences between them. For example, unequal junction temperatures in the amplifier's input transistors can cause large offset-voltage and offset-current shifts.

As shown in the chip drawing and schematic, cross-coupling of the input stages cancels differences in the low-level transistors' junction temperatures. It is also necessary to lay out the stage's associated resistors to minimize temperature gradients. In this case, all input-stage resistors are arranged in the same epitaxial tub (and in the same direction) to ensure that all resistors are equally affected by the unavoidable heating.

A CASE STUDY

Note the isothermal lines shown in the chip drawing. Q_{25} and Q_{26} are at equal temperatures; these two current-mirror transistors must have the same

base-emitter voltages. It's a different story, however, for Q_{21} and Q_{22} . They lie farther away from the power section, and layout considerations have made it impossible to keep them at equal temperatures. The same problem also exists for Q_{20} and Q_{23} . For the purposes of illustration, assume that a dissipation-induced temperature rise causes the base-emitter voltage of Q_{25} and Q_{26} to drop by 3 mV. Transistor Q_{22} is slightly cooler and suffers a V_{BE} decrease of 2 mV while the comparable Q_{21} drop is only 1.5 mV. Finally, Q_{20} and Q_{23} exhibit V_{BE} changes of 1 mV and 0.5 mV, respectively. As a result of thermal cross-coupling, the V_{BE} reductions from either input can be matched at 2.5 mV. The base-emitter voltage variations as a function of temperature thus cancel out. Without this cross-coupling, the total change in base-emitter voltage would be 3 mV for the left input stage and 2 mV for the right input stage.

CURRENT-SENSE TRANSCONDUCTANCE

The op amps' current-sense terminals can be used to derive a transconductance function. This function is commonly used in motor control applications such as voice-coil servo or microstepping positioning systems found in many computer disk drives. The drawing at right shows the ULN-3755W dual amplifier connected as a transconductance amplifier. In this example, amplifier B is used as a slave to amplifier A. Feedback from the pair of current-sensing resistors, R_S , in the emitters of the output's current-sinking transistors is applied to the summing network and scaled to the inverting input of amplifier A, where it is compared to the input voltage.

The voltage developed across the sensing resistors is directly proportional to the output current. Using this voltage as a feedback source defines the gain of the circuit as output current in amperes as a function of the input voltage in volts. The gain thus assumes the dimensions of a transconductance function (output current divided by input voltage), expressed in siemens (formerly mhos).

Conventional monolithic power op amps can be made to operate in similar configurations where the current-sensing resistor(s) are inserted in the ground (or negative supply) return. However, that configuration is not recommended, since both the amplifier's signal and bias currents now flow through the output current sensing resistor(s), causing the high-gain signal ground to float. Operating in this mode can cause problems with stability and common-mode rejection, as well as reducing the input common-mode range. The dual power op amps in the Series ULN-3750, however, provide open-emitter outputs that can be used to sense current without degradation of the input characteristics of the high-gain stages.

The graphs below illustrate the bidirectional nature of output load current (and the same current divided between the two output sink returns).

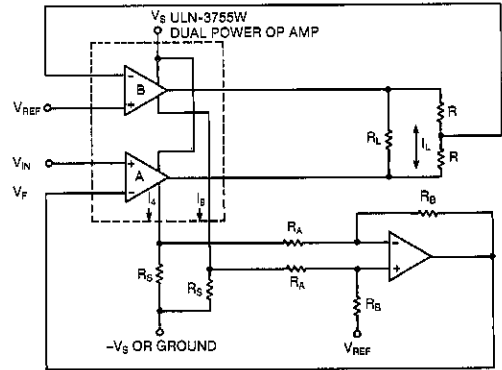

TRANSCONDUCTANCE AMPLIFIER

Dwg. No. W-119

$I_A - I_B = I_L$. The external network sums and amplifies (scales) the voltages developed across the current-sensing resistors. The resulting feedback voltage (V_F) is a scaled, level-shifted version of the load current. It is possible, in certain applications, to combine this network with the input-feedback network and eliminate the small-signal operational amplifier.

The negative feedback forces the amplifier to adjust the output current to attain a value such that the feedback voltage equals the applied input voltage. The transfer function of the transconductance amplifier is approximately:

$$I_L / (V_{IN} - V_{REF}) = R_A / (R_B R_S)$$

Resistors R_A , R_B , and R_S define the transconductance gain. To avoid limiting the transconductance amplifier's output compliance (swing capability), low-value current-sensing resistors (R_S) should be used. The product of peak output current and sensing resistance should be kept to as low a value as possible.

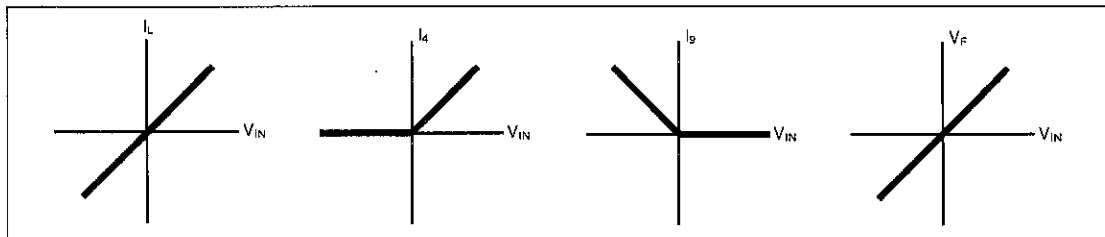

Dwg. No. W-120

DIGITALLY CONTROLLED POSITION SERVO

In a position-control application, a microprocessor is often used to control a servomotor's shaft angle or to control position, as in a computer disk drive. Below is a typical discrete semiconductor circuit implementation of that concept. The basic configuration is a classic one, using two low-power operational amplifiers, many discrete passive components, and four PNP and NPN power transistors connected in a push-pull, H-bridge configuration.

The circuit consists of small-signal input operational amplifiers and power output stages. The circuit derives its input from the D/A converter, whose output is determined by a code from the controlling microprocessor and related digital-control circuitry.

The analog equivalent of this servo-control circuit might use a multi-turn potentiometer to produce a voltage proportional to the servomotor's position. In any event, the sensed position signal normally undergoes processing and comparison with the desired position, through a digitally-based microprocessor system (or its analog equivalent) that produces an error signal to control the servo amplifier's output.

A circuit that uses far fewer components to accomplish the same position-control function is constructed around the ULN-3755W integrated circuit. In addition to the original functions, the circuit now includes thermal and short-circuit protection, as well as component matching and thermal tracking inherent to monolithic construction. The ULN-3755W dual power operational amplifier has its two independent outputs connected in a push-pull, H-bridge configuration. An 8-bit D/A converter yields a resolution of 256 shaft positions in discrete steps of 1.41°. A higher resolution converter would, of course, provide finer control. Because of its push-pull arrangement, the circuit provides bidirectional servo control.

The overall resolution of the system is a function of the position-sensing element, whether a digitally encoded disk or an analog potentiometer, and the digital control circuitry, including the microprocessor and the A/D converter. The ULN-3755W dual operational amplifier combines the small-signal summing amplifiers, predrivers, and the output H-bridge. The IC's outputs also include clamping diodes with current-handling capacity equal to that of the output drivers.

DISCRETE CIRCUIT IMPLEMENTATION

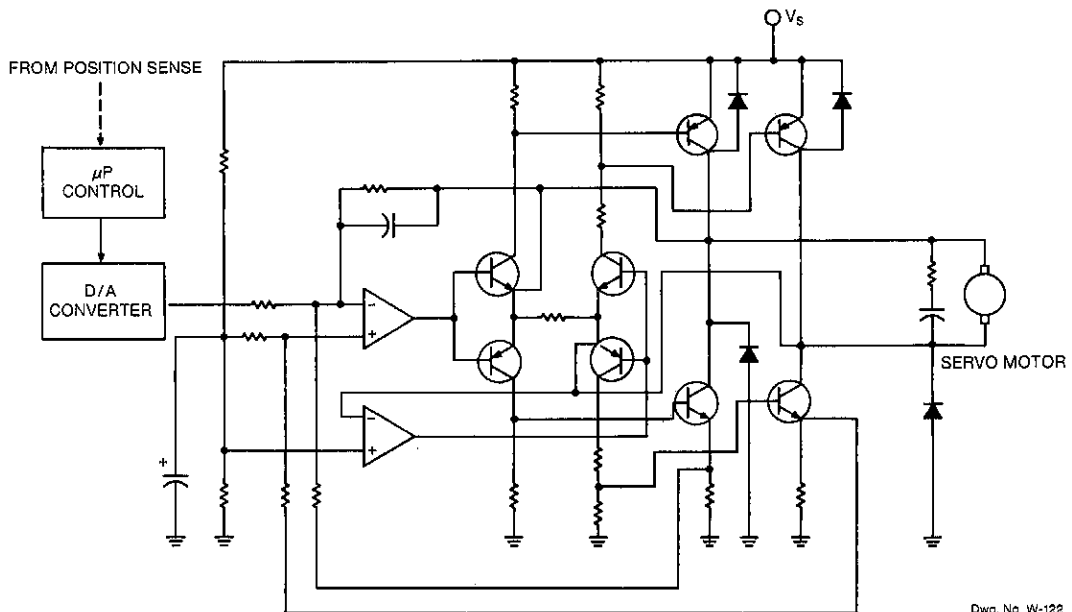

Dwg. No. W-122

DIGITALLY CONTROLLED POSITION SERVO — INTEGRATED CIRCUIT IMPLEMENTATION

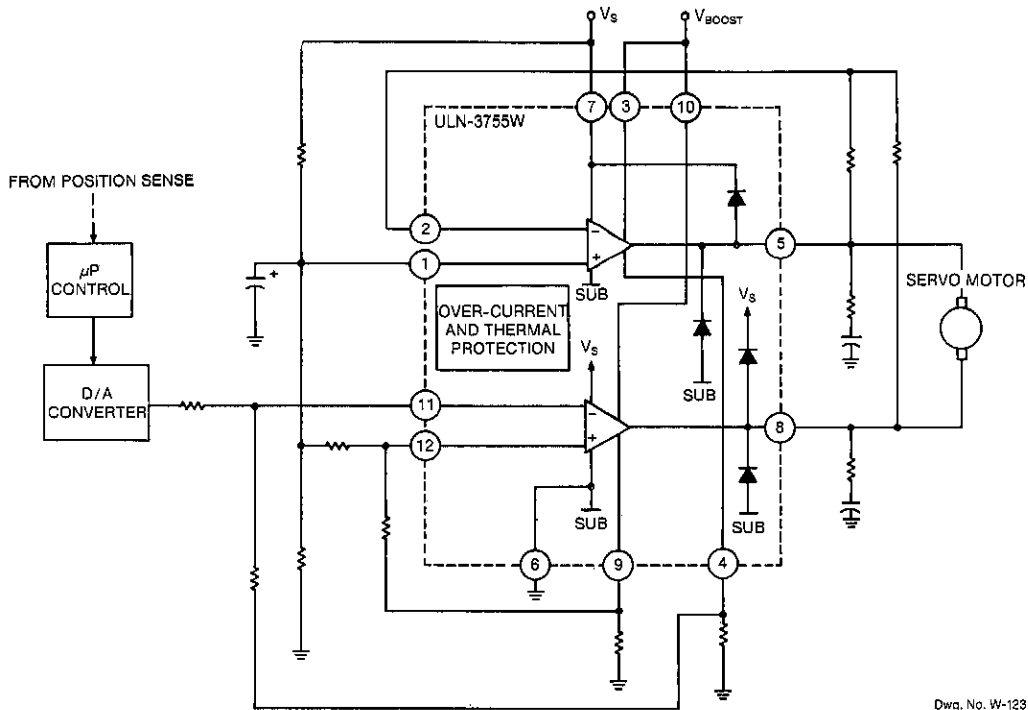

Dwg. No. W-123

4

The current-sense pins (4 and 9) provide access to the emitters of the H-bridge current sinks, thereby providing convenient output-current sensing to ground (or to the negative rail), while allowing separate low-current signal ground returns. This feature helps to prevent undesirable feedback to the input stage, a common problem with conventional approaches to output-current sense.

If a voltage higher than the supply is applied to the ULN-3755W boost pins, the positive output swing is limited only by the saturation resistance of the output transistors (typically less than 0.5Ω). For example, with a 12 V supply, the circuit typically supplies a 10.5 Vpp output swing at 1 A output current. This figure is at least 1 V higher than can be expected from ICs lacking the boost capability. Note that the externally supplied boost voltage should be at least 3 V higher than the load supply voltage. This criterion satisfied, the boost voltage can be any value within the IC's 40 V absolute-maximum rating. The circuit shown will deliver continuous output currents of up

to ± 2.5 A and peak output currents as high as ± 3.5 A.

The user must be aware that although the voltage or current limits shown are well within the IC's capabilities, the resultant power dissipation must be kept within the constraints of the overall (chip + package + heat sink) thermal rating. This rating is principally dependent on the package chosen and the amount of heat sinking provided by the user.

The boost feature provides important additional output voltage swing at the amplifier's full rated current. However, the IC's boost input requires only a low, unregulated current of 25 mA, maximum. Thanks to this modest current requirement, the boost voltage can be obtained from such compact sources as inexpensive, modular dc to dc converters. Or, in a head-positioning application in a disk drive, for example, a simple overwinding in the spindle motor (or a voltage doubler using the motor's driven phases) can easily generate such a voltage.

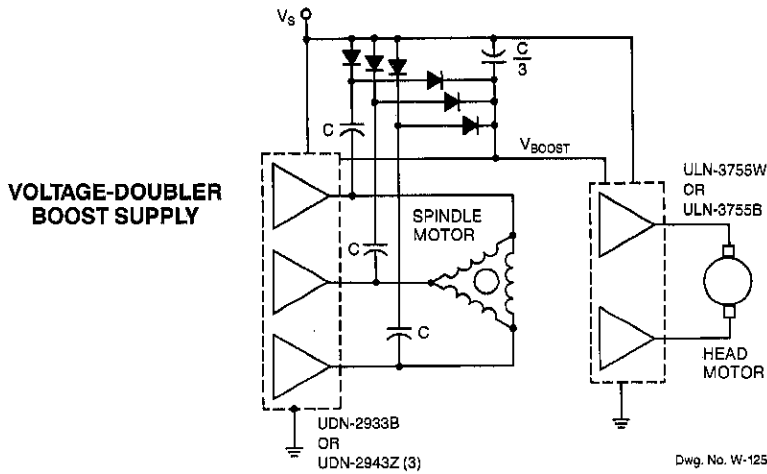

SIMPLE VOLTAGE DOUBLERS FOR OP AMP BOOST

An example of a simple-to-implement voltage-doubler boost supply is shown above. This circuit affects the doubling by connecting a series diode-capacitor network between the main supply and each of the spindle motor's driven phases. A three-diode bridge then charges the voltage-doubling capacitor to nearly twice the main supply voltage. Note that connecting the capacitor to the main supply (instead of to ground) effectively reduces rms ripple in the main supply by injecting its charge current into the supply mains concurrently with the spindle's opposing drive currents. Although, in theory, only one

motor phase is needed to generate the boost, the three-phase connection is recommended to prevent unbalancing the spindle.

Below is a similar circuit using a ULN-3755W to provide linear drive to a delta-connected spindle motor. The use of linear drive instead of pulse-width-modulation results in much lower noise with only a slight reduction in efficiency. Because fast PWM transitions in the circuit above result in motor losses, the efficiency compromise of the linear configuration is not as significant as might be expected.

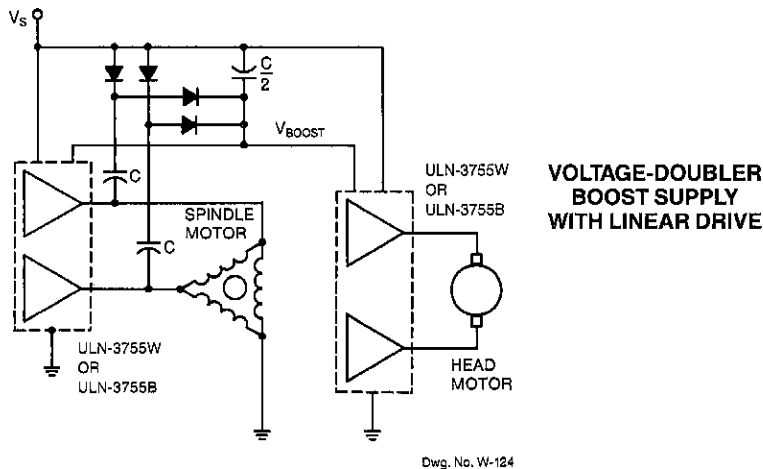

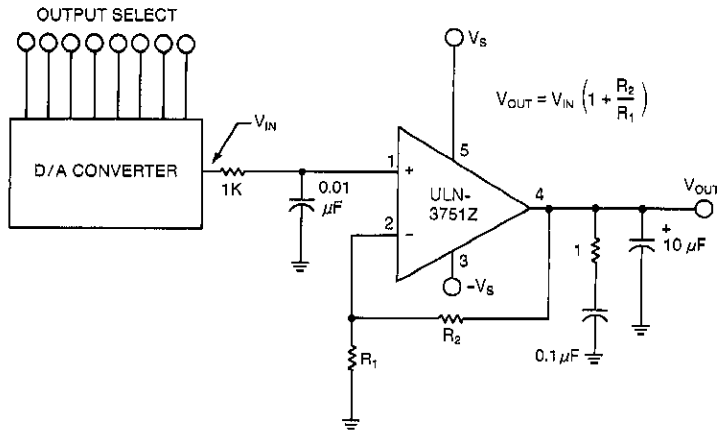

POSITIVE-OUTPUT PROGRAMMABLE REGULATOR

Dwg. No. W-126

HIGH-CURRENT REGULATORS

The high current-output capability of the operational amplifiers in Series ULN-3750 makes them suitable for use in linear voltage regulators. The amplifiers' high open-loop gain and low offset voltage ensure high load regulation and accuracy. Consider, for example, the positive-output, programmable regulator above. The circuit provides output currents as high as ± 3.5 A peak. Unlike most monolithic regulators, the ULN-3751Z is equally effective as a sink or a source. Therefore, the circuit maintains regulation for active loads that present reversing load currents. Note that the circuit easily handles transitions from high to low output voltages, thanks to the crowbar effect of the output's sinking capability. The input reference is the output of a D/A converter,

providing programmability. An 8-bit D/A, for example, provides for 256 steps of output resolution.

For higher output currents (but without the sink capability) the addition of an external power transistor (below) provides outputs as high as the NPN power transistor's safe operating area allows. This circuit is shown using a voltage reference such as the popular three-terminal TL431. The voltage V_Z is determined by the ratio of resistors R_3 and R_4 , while R_5 provides bias current. The circuit can, of course, be programmed by substituting the D/A reference above. The amplifier's output voltage is a function of the ratios of R_1 and R_2 . The PNP transistor provides short-circuit (I_{SC}) current limiting according to the expression shown.

4

POSITIVE OUTPUT REGULATOR WITH SHORT-CIRCUIT LIMITING

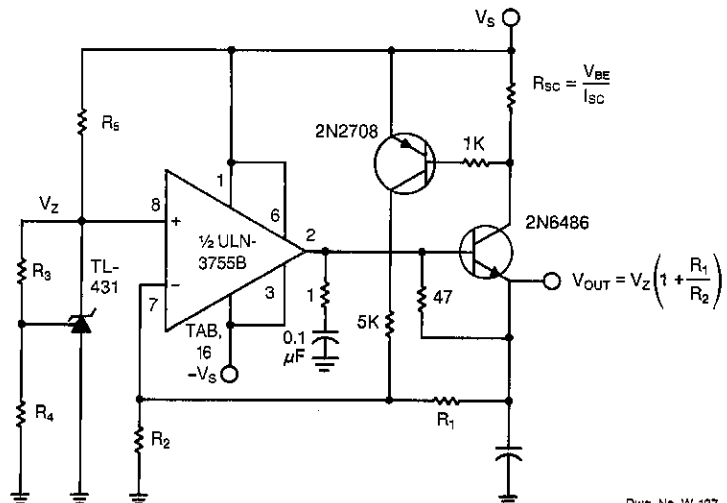

Dwg. No. W-127

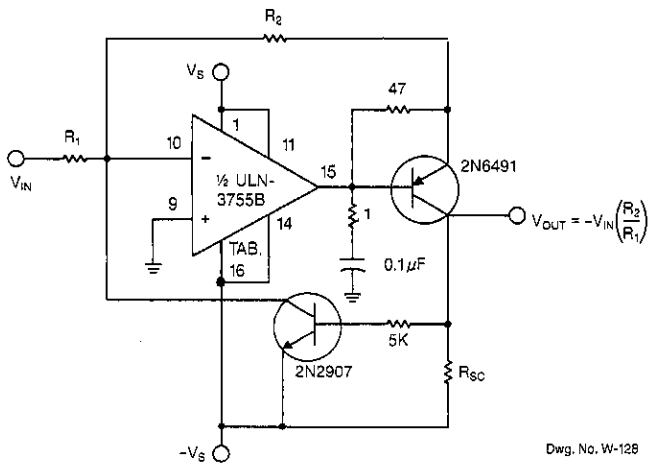

**HIGH-CURRENT
NEGATIVE OUTPUT
REGULATOR**

Dwg. No. W-128

HIGH-CURRENT REGULATORS (Continued)

To configure a high-current, dual-output supply, the mirror-image circuit shown at top can be used. Simply connect this stage's input to the D/A converter or voltage reference output. The combination of this circuit and the positive output regulator on the previous page provides an accurately tracking pair of positive and negative supplies from a common reference, whether a programmable D/A converter or the simple resistor-programmed TL431. Both circuits use the ULN-3755B with external high-current pass transistors. The external devices are unnecessary if output-current loading is less than 2.5 A.

The previously described boost capability can be used to good advantage in these regulator circuits. Applying a low-current boost voltage at least 3 V higher than the load supply voltage results in a regulator with less than 1 V input-output differential, (dependent on output current) yielding high efficiency from the main supply. The 0.1 Ω /0.1 μ F network at

the amplifier's output provides local compensation for the output stage.

A simple split supply can also be developed using a single ULN-3751Z power op amp to generate an artificial ground, as shown below. By taking advantage of the device's four-quadrant sink/source drive capability, the outputs will ratio (rather than track) over a wide range of supply voltages and unequal load currents. *Total* load current is unrestricted, provided the *difference* in load currents is less than the maximum rated current of the power op amp. In addition, the allowable package power dissipation rating must be greater than the product of the amplifier's sourcing current ($I_A < I_B$) and the source driver voltage (V_A) or the sinking current ($I_A > I_B$) and the sink driver voltage (V_B). This circuit is also very useful in tracking supplies to enhance common-mode supply rejection.

**ARTIFICIAL GROUND /
SPLIT SUPPLY**

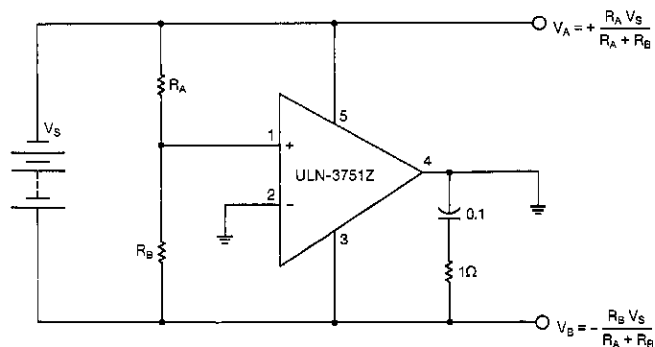

Dwg. No. W-129

DC MOTOR SPEED CONTROL

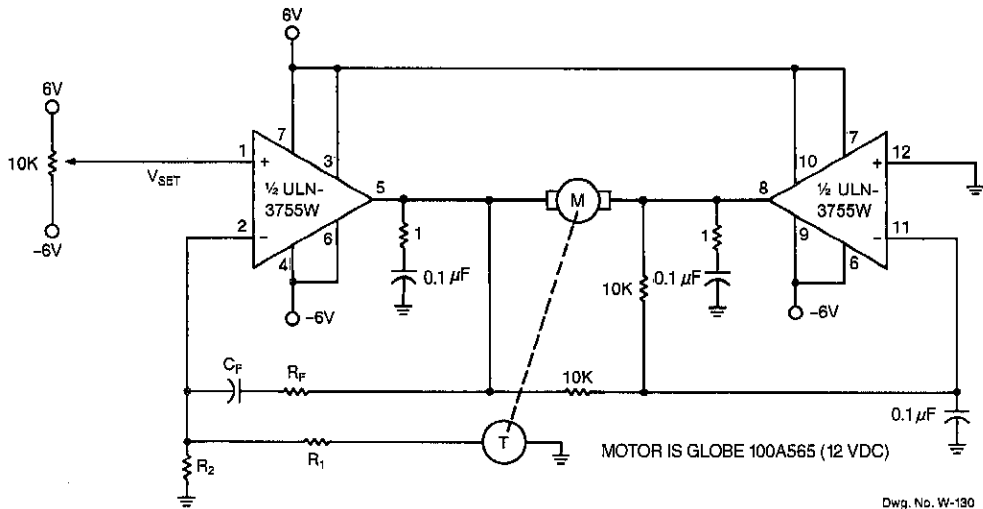

ICs CONTROL MOTOR SPEED

Power op amps can be used to provide accurate speed control for dc motors. The drawing above shows a closed-loop system for controlling the speed of a 12 V dc motor. The circuit provides bidirectional speed control. The amplifiers' push-pull configuration ensures a full rail-to-rail voltage swing (minus the output stages' saturation drops) across the motor in either direction.

The circuit uses a mechanically-coupled tachometer to provide speed-stabilizing feedback to the first amplifier section. The motor's speed and direction of rotation is set by adjusting the 10 k Ω potentiometer at the amplifier's noninverting input.

The motor speed, in rpm, is:

$$S = V_{SET}(R_1 + R_2)/0.0027 R_2$$

The $R_F C_F$ feedback network prevents oscillation by compensating for the inherent dynamic mechanical lag of the motor. Select the $R_F C_F$ time constant to match the particular motor's characteristics. By consulting with individual motor data sheets, the R_F and C_F values can be chosen to match the motor response or dynamic time constant. This should yield a good starting point for stabilizing the system. Optimal response is achieved by varying the compensating capacitor.

SINGLE-PHASE AC MOTOR DRIVER

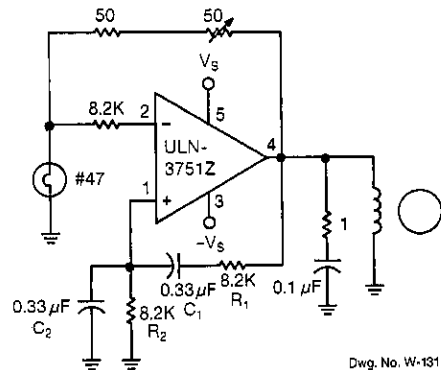

Dwg. No. W-131

N-PHASE MOTOR DRIVE

Its high amplification factor and its built-in power-output stage make the integrated power operational amplifier a convenient driver for single-phase or multiphase ac motors. The high gain allows one op amp to be configured as an oscillator to generate the required ac signal. The power-output stage, of course, supplies the high-current drive to the motor.

Consider, for example, the three motor-drive circuits shown here. The circuit above is a single-phase driver that uses the ULN-3751Z single power op amp. The other circuits use the ULN-3755W dual amplifier to drive two-phase and three-phase motors. Note that in all three circuits, the controlling

op amp is configured as a Wein-bridge power oscillator. The R_1C_1 and R_2C_2 feedback networks determine the oscillation frequency according to the expression:

$$f_o = 1/(2\pi\sqrt{R_1R_2C_1C_2})$$

By varying either R_1 or R_2 , the oscillator frequency can be adjusted over a narrow range.

In the single-phase and two-phase examples, the oscillation frequency is 60 Hz. In the three-phase example, the frequency is 400 Hz. The Type 47 incandescent light bulb in the oscillator circuits serve to stabilize the amplifier's output amplitude. The bulb owes its stabilization qualities to its intrinsic positive

TWO-PHASE AC MOTOR DRIVER

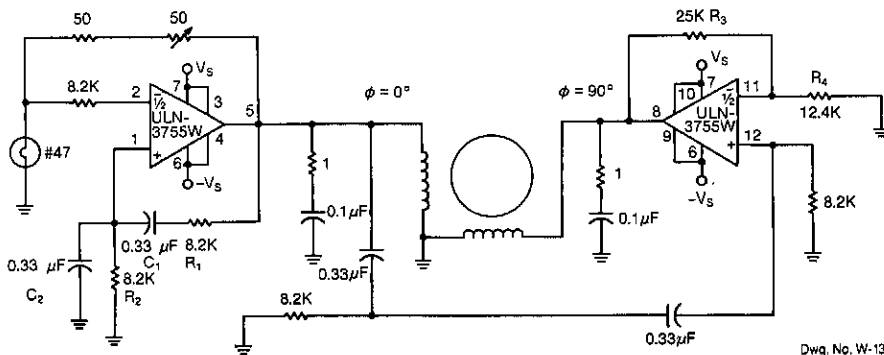

Dwg. No. W-132

THREE-PHASE AC MOTOR DRIVER

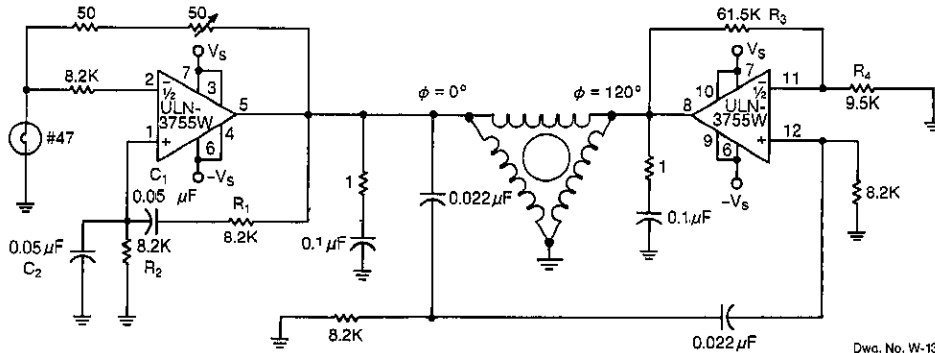

Dwg. No. W-133

temperature coefficient. If the amplifier's output level attempts to increase, the corresponding increase in lamp current causes a temperature rise in the filament. The heating, in turn, results in an increase in filament resistance, producing increased negative feedback and a reduction in amplifier gain. A PTC (positive temperature coefficient) resistor could be used instead of the lamp. To set the output amplitude, adjust the 50 Ω potentiometer in the feedback network.

To drive multiphase motors, it's a relatively simple matter to add another stage to the single-phase circuit. In the 60 Hz, two-phase drive, the 8.2 k Ω /0.33 μ F networks provide both the 60 Hz oscillator frequency and the 90° phase shift needed by the right-hand amplifier. The 8.2 k Ω /0.005 μ F networks in the three-phase drive set the 400 Hz oscillator frequency, while the 8.2 k Ω /0.022 μ F networks provide the required

120° of phase shift. The motor shown is a three-phase delta-connected motor with one input grounded and the remaining inputs driven from the 0° and 120° phase-shifted amplifier outputs. The result is a balanced three-phase a-c drive.

In both the two-phase and three-phase circuits, the R_3/R_4 ratio sets the second amplifier's gain to compensate for signal attenuation occurring in the phase shifters. Again, pins 3 and 10 can be returned to a boost supply to obtain additional output-swing capability.

The three circuits can all be driven from an external source, such as a pulse or square wave output of a digital source, setting the gain of the left-hand amplifier to a level less than that required for oscillation. The RC feedback networks then function as active filters, causing the outputs to be sinusoidal.

UNIVERSAL BUILDING BLOCKS

Power operational amplifiers provide a fundamental set of universal building blocks incorporating the merged equivalent of small-signal operational amplifiers, pre-drivers, output amplifiers and various protective features such as output clamp diodes, thermal shutdown, and output-current limiting. An output-boost capability can provide for high output-

voltage swing, while an output-current-sensing scheme prevents unwanted interaction between the outputs and inputs. Many applications that previously required individual low-level and high-level components can now be implemented with a single integrated circuit and few external components.

4

NOTES
