

Description

The 1-inch Solid State Disk is small in size, has a huge capacity and low power consumption making it perfect for use as a mobile storage solution in devices such as, Mobile Phones, PDA and GPS systems. This guide is written to provide general installation and handling information, please use it in conjunction with the Owner’s Manual for your device or system.

Placement

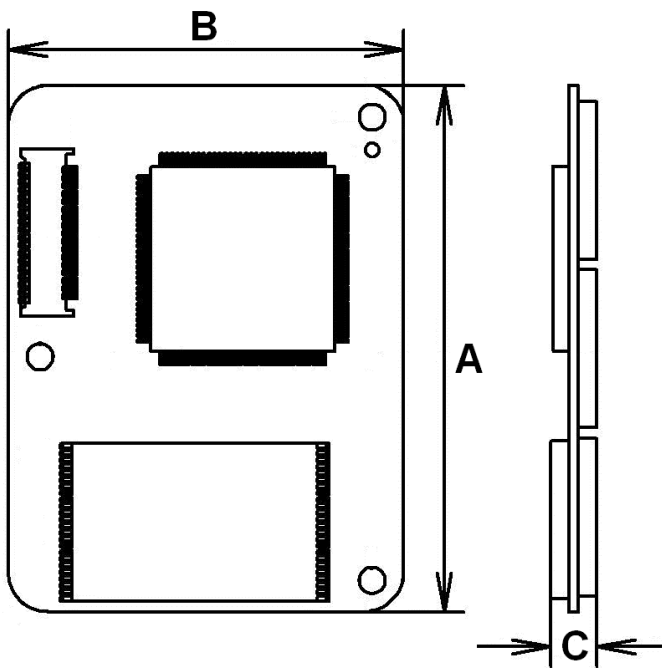

Features

- RoHS compliant
- Fully compatible with 1.0-inch hard drive form factor and interface (35-Pin FPC ZIF connector)
- Non-volatile Flash Memory for outstanding data retention
- Built-in 13/24 ECC (Error Correction Code) functionality and wear-leveling algorithm ensures highly reliable of data transfer
- Supports up to PIO Mode 4 and Ultra DMA Mode 5
- Supports ATA Security Commands
- Support S.M.A.R.T function (self-definition)
- Lower Power Consumption
- Shock resistance
- Power Supply: 3.3V ± 5%

Dimensions

Side	Millimeters	Inches
A	40.00 ± 0.30	1.575 ± 0.012
B	30.00 ± 0.20	1.181 ± 0.008
C	3.80 ± 0.50	0.149 ± 0.020

TS2GSSD10-M ~ TS32GSSD10-M

1.0" Solid State Disk

Specifications

Physical Specification		
Form Factor	1-inch HDD	
Storage Capacities	2 GB to 32 GB	
Dimensions (mm)	Length	30.0 0 ± 0.20
	Width	40.00 ± 0.30
	Height	3.80 ± 0.50
Weight	6 g	
Connector	0.3 mm pitch 35-Pin Zero Insertion Force (ZIF) connector (P-ATA)	

Environmental Specifications	
Operating Temperature	0 °C to 70 °C
Storage Temperature	- 40 °C to 85 °C

Humidity	
Operating Humidity (Non condensation)	5% to 95%
Storage Humidity (Non condensation)	5% to 95%

* Note: Reference to the IEC 60068-2-1 and IEC 60068-2-56 Testing procedures; 48-hours chamber test on ASUS M2N-MX, 1GB RAM, Windows® XP Version 2002 SP2.

Power Requirements			
Input Voltage	DC 3.3V ± 5%		
Power Consumption (DC 3.3V @25°C)	Mode	TYP (mA)	MAX (mA)
	Write	84.5	93.4
	Read	55.1	68.4
	Standby	0.4	1.3

* Note: Base on TS16GSSD10-M

TS2GSSD10-M ~ TS32GSSD10-M

1.0" Solid State Disk

Reliability	
Data Reliability	13bit/1KB BCH ECC(2k+64 / 4k+128 byte per page flash) 24bit/1KB BCH ECC(4k+208 byte per page flash)
Data Retention	10 years
Connector Durability	10 times
MTBF	4,400,000 hours

Interface Specification	
Drivers	No Device Driver Required
ATA Compatibility	ATA/ATAPI 7
	PIO Modes 0 - 4
	Multiword mode 0 - 2
	UDMA Modes 0 - 5

Performance					
Model P/N	Capacity	Read	Write	Random Read	Random Write
TS2GSSD10-M	2GB	35213	7867	33952	2151
TS4GSSD10-M	4GB	35371	12248	33602	2674
TS8GSSD10-M	8GB	47805	10586	45816	3431
TS16GSSD10-M	16GB	45169	12134	40943	3796
TS32GSSD10-M	32GB	43686	16756	41457	3567

* Note : 25 °C, according to 44 pin to 40 pin IDE transferring cable test on ASUS M2N-MX, 1GB RAM, IDE interface support UDMA4, Windows® XP Version 2002 SP2, benchmark utility HDBENCH (version 3.4006), copied file 100MB

Actual Capacity				
Model P/N	Capacity	Cylinder	Head	Sector
TS2GSSD10-M	2GB	3884	16	63
TS4GSSD10-M	4GB	7769	16	63
TS8GSSD10-M	8GB	15538	16	63
TS16GSSD10-M	16GB	33149	15	63
TS32GSSD10-M	32GB	66298	15	63

* Note: FAT32 format

Regulations	
Compliance	CE, FCC and BSMI (T.B.D.)

Package Dimensions

Below figure illustrates the Transcend 1" Solid State Disk. All dimensions are in mm.

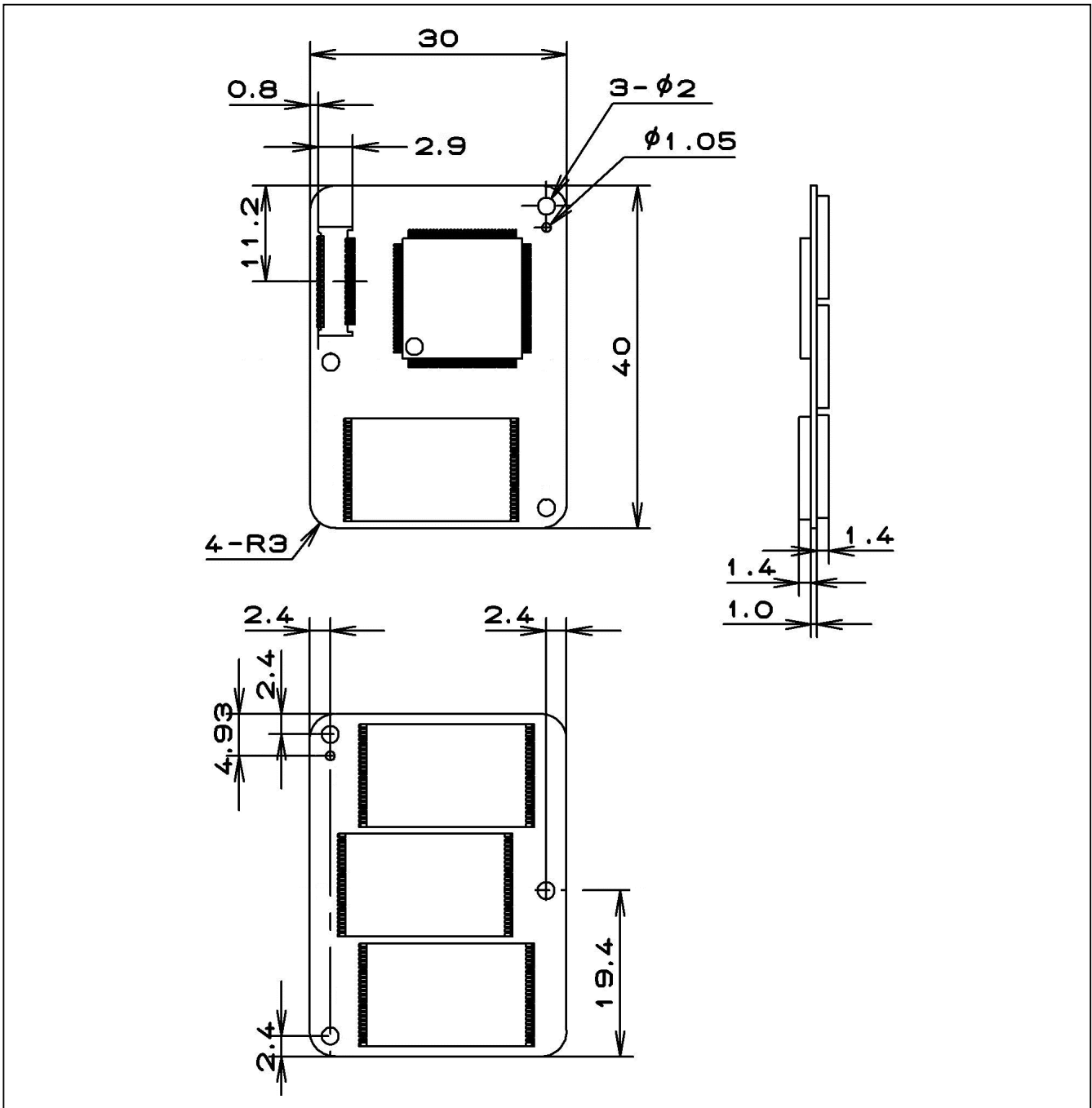

Pin Assignments

Pin No.	Pin Name	Pin No.	Pin Name
01	GND	02	DD10
03	DD9	04	DD2
05	DD8	06	DD1
07	-PDIAG	08	DD0
09	-DASP	10	DA0
11	-DMACK	12	DA1
13	DMARQ	14	DA2
15	IORDY	16	-RESET
17	-CSEL	18	VCC
19	VCC	20	INTRQ
21	-DIOW	22	-DIOR
23	-CS1	24	-CS0
25	DD15	26	DD7
27	DD14	28	DD6
29	DD13	30	DD5
31	DD12	32	DD4
33	DD11	34	DD3
35	GND		

Pin Layout

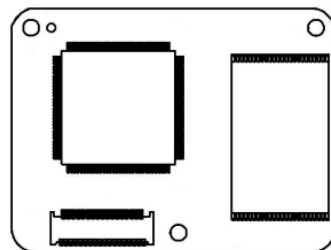

Pin out

01 02 03 04 05 06 07 08 09 10 11 12 13 14 15 16 17 18 19 20 21 22 23 24 25 26 27 28 29 30 31 32 33 34 35

GND DD10 DD9 DD2 DD8 DD1 -PDIAG DD0 -DASP DA0 -DMACK DA1 DMARQ DA2 IORDY -RESET -CSEL VCC VCC INTRQ -DIOW -DIOR -CS1 -CS0 DD15 DD7 DD14 DD6 DD13 DD5 DD12 DD4 DD11 DD3 GND

Block Diagram

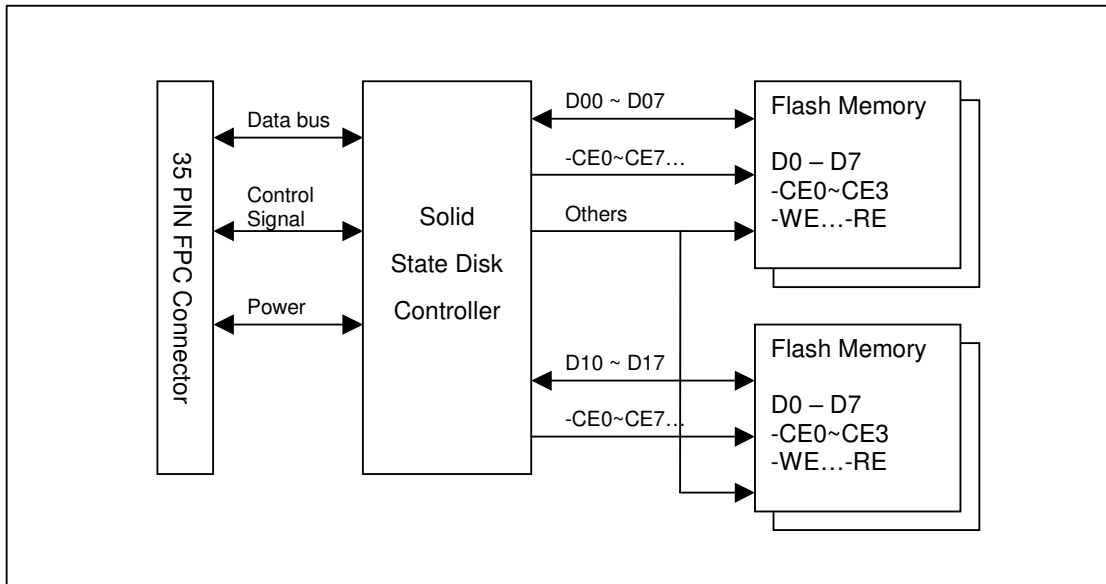

DC Characteristics

Parameter	Symbol	Min.	Max.	Unit	Remark
Supply Voltage	V_{CC}	2.97	3.63	V	
High level output voltage	V_{OH}	$V_{CC} - 0.8$		V	
Low level output voltage	V_{OL}		0.8	V	
High level input voltage	V_{IH}	2.4		V	Non-schmitt trigger
		2.05		V	Schmitt trigger ¹
Low level input voltage	V_{IL}		0.6	V	Non-schmitt trigger
			1.25	V	Schmitt trigger ¹
Pull up resistance ²	R_{PU}	52.7	141	KOhm	
Pull down resistance	R_{PD}	47.5	172	kOhm	

Note: 1. Include CS0#, CS1#, DMACK, HIOR#, HIOW# pins.

2. Include CS0#, CS1#, DMACK, HIOR#, HIOW#, CSEL#, PDIAG#, DASP# pins.

Command Set

	Command	Code	FR	SC	SN	CY	DH	LBA	Status	Note
1	Check Power Mode	E5 or 98h	-	-	-	-	Y	-	Support	
2	Execute Drive Diagnostic	90h	-	-	-	-	Y	-	Support	
3	Erase Sector	C0h	-	Y	Y	Y	Y	Y	Support	
4	Flush Cache	E7h	-	-	-	-	Y	-	Support	
5	Format Track	50h	-	Y	-	Y	Y	Y	Support	
6	Identify Device	ECh	-	-	-	-	Y	-	Support	
7	Idle	E3h or 97h	-	Y	-	-	Y	-	Support	
8	Idle Immediate	E1h or 95h	-	-	-	-	Y	-	Support	
9	Initialize Drive Parameters	91h	-	Y	-	-	Y	-	Support	
10	Key Management Structure Read	B9 (Feature 0-127)	Y	Y	Y	Y	Y	-	NOT Support	#1
11	Key Management Read Keying Material	B9 (Feature 80)	Y	Y	Y	Y	Y	-	NOT Support	#1
12	Key Management Change Key Management Value	B9 (Feature 81)	Y	Y	Y	Y	Y	-	NOT Support	#1
13	NOP	00h	-	-	-	-	Y	-	NOT Support	
14	Read Buffer	E4h	-	-	-	-	Y	-	Support	
15	Read DMA	C8h	-	Y	Y	Y	Y	Y	Support	
16	Read Long Sector	22h or 23h	-		Y	Y	Y	Y	NOT Support	#2
17	Read Multiple	C4h	-	Y	Y	Y	Y	Y	Support	
18	Read Sector(s)	20h or 21h	-	Y	Y	Y	Y	Y	Support	
19	Read Verify Sector(s)	40h or 41h	-	Y	Y	Y	Y	Y	Support	
20	Recalibrate	1Xh	-	-	-	-	Y	-	Support	
21	Request Sense	03h	-	-	-	-	Y	-	Support	
22	Security Disable Password	F6h	-	-	-	-	Y	-	Support	
23	Security Erase Prepare	F3h	-	-	-	-	Y	-	Support	
24	Security Erase Unit	F4h	-	-	-	-	Y	-	Support	
25	Security Freeze Lock	F5h	-	-	-	-	Y	-	Support	
26	Security Set Password	F1h	-	-	-	-	Y	-	Support	
27	Security Unlock	F2h	-	-	-	-	Y	-	Support	

28	Seek	7Xh	-	-	Y	Y	Y	Y	Support	
29	Set Feature	EFh	Y	-	-	-	Y	-	Support	
30	Set Multiple Mode	C6h	-	Y	-	-	Y	-	Support	
31	Set Sleep Mode	E6h or 99h	-	-	-	-	Y	-	Support	
32	Standby	E2 or 96h	-	-	-	-	Y	-	Support	
33	Standby Immediate	E0 or 94h	-	-	-	-	Y	-	Support	
34	Translate Sector	87h	-	Y	Y	Y	Y	Y	Support	
35	Wear Level	F5h	-	-	-	-	Y	-	Support	#4
36	Write Buffer	E8h	-	-	-	-	Y	-	Support	
37	Write DMA	CAh	-	Y	Y	Y	Y	Y	Support	
38	Write Long Sector	32h or 33h	-	-	Y	Y	Y	Y	Not Support	#2
39	Write Multiple	C5h	-	Y	Y	Y	Y	Y	Support	
40	Write Multiple w/o Erase	CDh	-	Y	Y	Y	Y	Y	Support	
41	Write Sector(s)	30h or 31h	-	Y	Y	Y	Y	Y	Support	
42	Write Sector(s) w/o Erase	38h	-	Y	Y	Y	Y	Y	Support	
43	Write Verify	3Ch	-	Y	Y	Y	Y	Y	Support	

#1: This command is optional, depending on the key Management scheme in use.

#2: Use of this command is not recommended.

#3: If Security command 22~27 are supported, this command is not supported.

Definitions

FR = Features Register

SC =Sector Count register (00H to FFH, 00H means 256 sectors)

SN = Sector Number register

CY = Cylinder Low/High register

DH = Head No. (0 to 15) of Drive/Head register

LBA = Logic Block Address Mode Support

- = Not used for the command

Y = Used for the command

SMART Command Set

● SMART Command Set

SMART Feature Register Values			
D0h	Read Data	D5h	Read Log
D1h	Read Attribute Threshold	D6h	Write Log
D2h	Enable/Disable Autosave	D8h	Enable SMART Operations
D3h	Save Attribute Values	D9h	Disable SMART Operations
D4h	Execute OFF-LINE Immediate	DAh	Return Status

* If reserved size is below the Threshold, the status can be read from Cylinder register by Return Status command (DAh).

● SMART Data Structure

BYTE	F / V	Decription
0-1	X	Revision code
2-361	X	Vendor specific
362	V	Off line data collection status
363	X	Self-test execution status byte
364-365	V	Total time in seconds to complete off-line data collection activity
366	X	Vendor specific
367	F	Off-line data collection capability
368-369	F	SMART capability
370	F	Error logging capability
		7-1 Reserved 0 1=Device error logging supported
371	X	Vendor specific
372	F	Short self-test routine recommended polling time (in minutes)
373	F	Extended self-test routine recommended polling time (in minutes)
374	F	Conveyance self-test routine recommended polling time (in minutes)
375-385	R	Reserved
386-395	F	Date Code
396-397	F	Number of initial invalid block (396 = MSB, 397 = LSB)
398-399	V	Number of run time bad block (398 = MSB, 399 = LSB)
400	V	Number of spare block

511	V	Data structure checksum
-----	---	-------------------------

F=the content of the byte is fixed and does not change.
V=the content of the byte is variable and may change depending on the state of the device or the commands executed by the device.
X=the content of the byte is vendor specific and may be fixed or variable.
R=the content of the byte is reserved and shall be zero.

* 4 Byte value : [MSB] [2] [1] [LSB]

TS2GSSD10-M ~ TS32GSSD10-M

1.0" Solid State Disk

Ordering Information

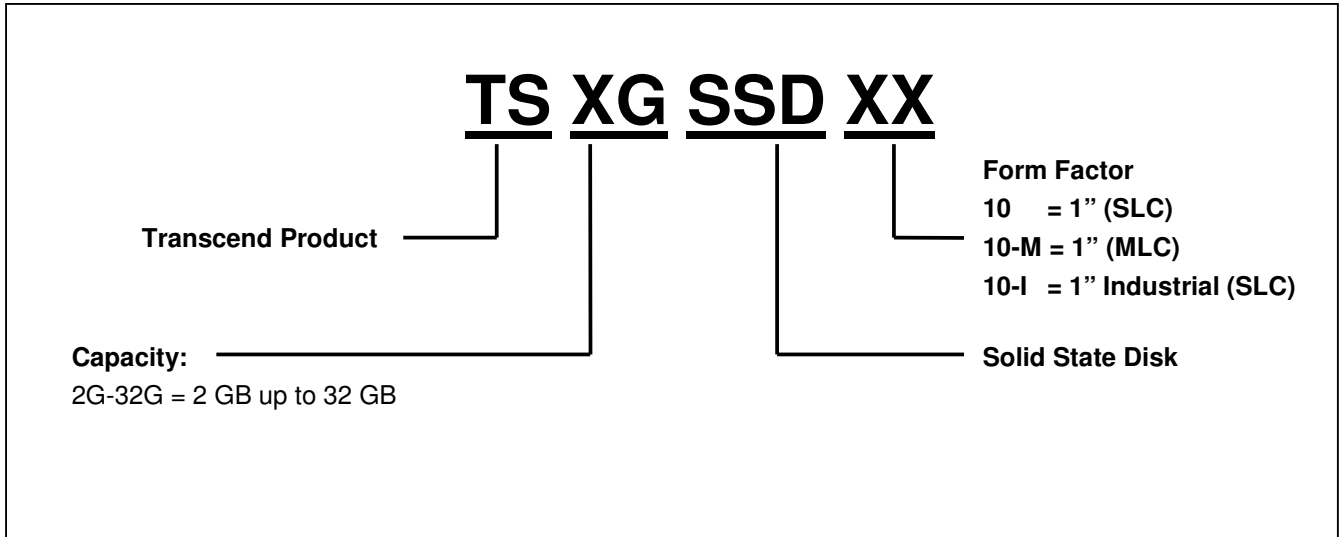

The above technical information is based on industry standard data and has been tested to be reliable. However, Transcend makes no warranty, either expressed or implied, as to its accuracy and assumes no liability in connection with the use of this product. Transcend reserves the right to make changes to the specifications at any time without prior notice.



TAIWAN

No.70, XingZhong Rd., NeiHu Dist., Taipei, Taiwan, R.O.C
TEL +886-2-2792-8000
Fax +886-2-2793-2222
E-mail: sales@transcend.com.tw
www.transcend.com.tw

USA

Los Angeles:
E-mail: sales@transcendusa.com
Maryland:
E-mail: sales_md@transcendusa.com
www.transcendusa.com

JAPAN

E-mail: sales@transcend.co.jp
www.transcend.jp

CHINA

E-mail: sales@transcendchina.com
www.transcendchina.com

GERMANY

E-mail: vertrieb@transcend.de
www.transcend.de

HONG KONG

E-mail: sales@transcend.com.hk
www.transcendchina.com

Korea

E-mail: sales@transcend.co.kr
www.transcend.co.kr

THE NETHERLANDS

E-mail: sales@transcend.nl
www.transcend.nl

United Kingdom

E-mail: sales@transcend-uk.com
www.transcend-uk.com