

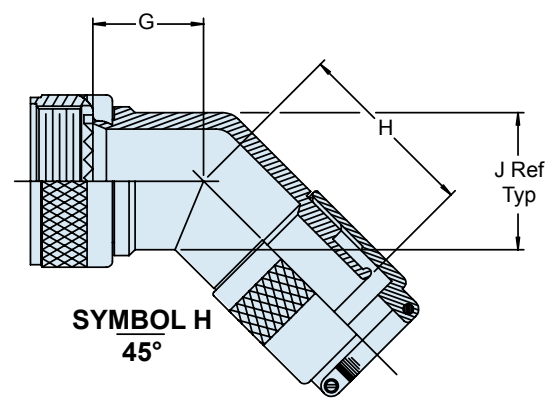

447-425
EMI/RFI Non-Environmental Band-in-a-Can Backshell
With Cable Clamp Strain-Relief
Rotatable Coupling - Standard Profile

Connector Designators:
 MIL-DTL-38999 Series I, II (F)
 MIL-DTL-38999 Series III and IV (H)

F-H
ROTATABLE
COUPLING

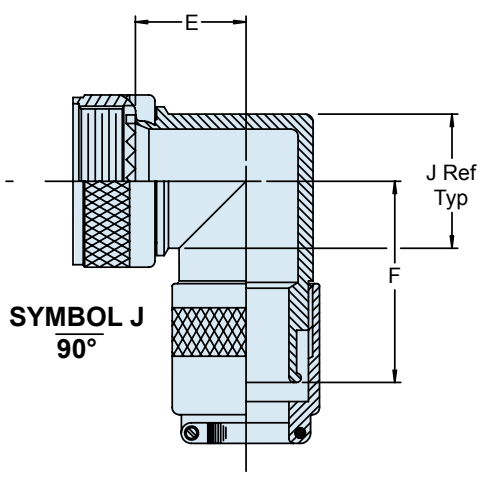
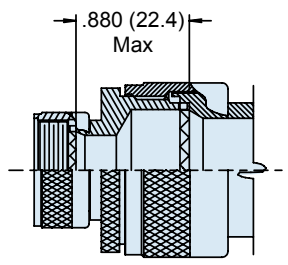
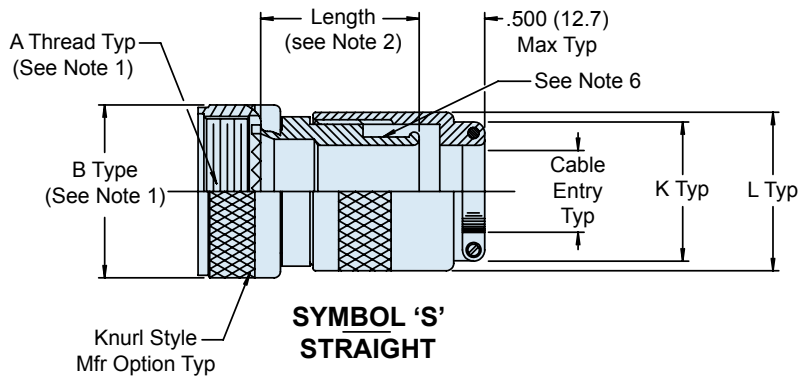
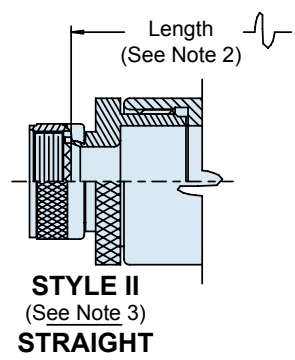
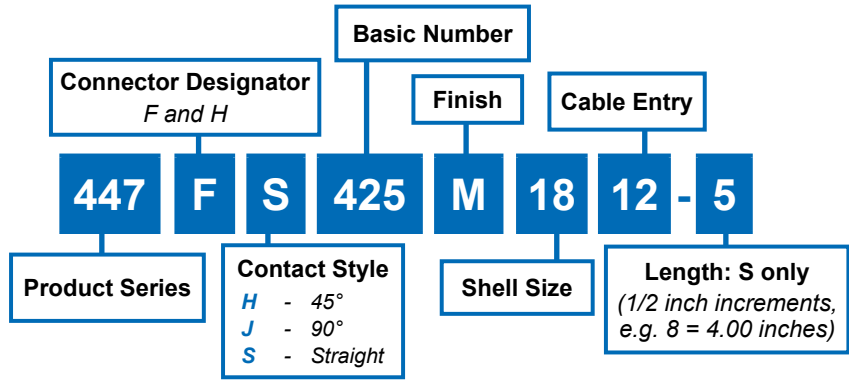

447-425
EMI/RFI Non-Environmental Band-in-a-Can Backshell
With Cable Clamp Strain-Relief
Rotatable Coupling - Standard Profile



TABLE III: BACKSHELL DIMENSIONS							
Shell Size		E Max.	F Max.	G Max.	H Max.	J Ref.	Max. Dash No. (F, H)
F	H						
08	09	0.75 (1.9)	1.5 (3.8)	0.639 (1.6)	1.38 (3.5)	0.45 (1.1)	01
10	11	0.81 (2.1)	1.55 (3.9)	0.664 (1.7)	1.41 (3.6)	0.58 (1.5)	02
12	13	0.87 (2.2)	1.61 (4.1)	0.688 (1.7)	1.43 (3.6)	0.69 (1.8)	04
14	15	0.92 (2.3)	1.68 (4.3)	0.705 (1.8)	1.46 (3.7)	0.82 (2.1)	05
16	17	0.98 (2.5)	1.74 (4.4)	0.732 (1.9)	1.48 (3.8)	0.94 (2.4)	06
18	19	1.02 (2.6)	1.76 (4.5)	0.748 (1.9)	1.49 (3.8)	1.03 (2.6)	06
20	21	1.08 (2.7)	1.82 (4.6)	0.773 (2.0)	1.51 (3.8)	1.16 (2.9)	07
22	23	1.14 (2.9)	1.90 (4.8)	0.800 (2.0)	1.55 (3.9)	1.28 (3.3)	08
24	25	1.20 (3.0)	1.97 (5.0)	0.823 (2.1)	1.58 (4.0)	1.41 (3.6)	09

TABLE IV: CABLE ENTRY				
Dash No.	K Max.	L Max.	Cable Entry	
			Min.	Max.
1	0.843 (2.1)	0.78 (2.0)	0.125 (0.3)	0.250 (0.6)
2	0.968 (2.5)	0.97 (2.5)	0.156 (0.4)	0.375 (1.0)
3	1.046 (2.7)	1.05 (2.7)	0.250 (0.6)	0.438 (1.1)
4	1.156 (2.9)	1.15 (2.9)	0.280 (0.7)	0.500 (1.3)
5	1.218 (3.1)	1.22 (3.1)	0.375 (1.0)	0.625 (1.6)
6	1.343 (3.4)	1.34 (3.4)	0.500 (1.3)	0.750 (1.9)
7	1.468 (3.7)	1.47 (3.7)	0.625 (1.6)	0.875 (2.2)
8	1.593 (4.0)	1.59 (4.0)	0.750 (1.9)	1.000 (2.5)
9	1.718 (4.4)	1.72 (4.4)	0.875 (2.2)	1.125 (2.9)
10	1.843 (4.7)	1.84 (4.7)	1.000 (2.5)	1.250 (3.2)

TABLE II: FINISHES	
Symbol	Finish
B	Cadmium Plate, Olive Drab
C	Anodize, Black
GB	Black Anodize, Hard Coat
M	Electroless Nickel
N	Cad Plate, Olive Drab over Electroless Nickel
NF	Cadmium Plate, Olive Drab over Electroless Nickel
MT	Ni-PTFE 1000 Hour Grey™ Nickel Fluorocarbon Polymer
Z1	Stainless Steel Passivate
ZL	CRES, Electroless Nickel
ZN	Zinc-Nickel

APPLICATION NOTES	
1. Standard minimum length for Style I is 1 inch (25.4), Style II is 1.5 inches (38.1). Consult factory about shorter lengths (Note: Applies to Symbol S Straight only).	5. For shield termination see Glenair Drawings 600-050 and 600-052.
2. When cable diameter exceeds "Max Dash No" in Table I, Style II will be supplied.	6. Material/Finish: Adapters, Elbows, Coupling Nuts, Ferrule, Clamp - Al Alloy/See Table I Hardware - Cres/Passivate
3. For effective grounding, connector with conductive finish should be used.	7. Metric dimensions (mm) are indicated in parentheses.
4. Glenair Series 600 Backshell Assembly tools are recommended for assembly and installation.	

