

Ceramic Discriminator for FM 10.7MHz

**JT10.7M Ceramic Discriminator
for FM (Murata CDA 10.7 Compatible)**



► Preview

Token ceramic discriminator is primarily designed for piezoelectric lines and conform to the RoHS directive and Lead-free.

Ceramic discriminator can be customized designs and tighter tolerances available on request. Application of ceramic discriminator specific designs also available including different piezo band-pass devices and Q specifications adjusted to frequency requirements.

TOKEN ceramic filters, discriminator, and trap filters can supply you high performance, high quality and stability.

JT10.7M for FM are resonated devices that offer adjustment free audio detection in both wide and narrow bandwidths. These IC dependent devices utilize FM specific detection methods to convert changes in frequency into an intelligible audio signal.

Characteristics :

1. Dimensions: (9.0 max x 7.0 max x 5.0 max) Unit: mm.
2. Center Frequency: 10.64MHz±30kHz, 10.64MHz±30kHz, 10.70MHz±30kHz, 10.73MHz±30kHz, and 10.76MHz±30kHz.
3. Available IC: TA7303P, TA7130, μ PC1028H, LA1150, TA8122AN, TA8132N, TA2007, TA2104AFN, TA2099N, TA2132P, CX-2009, CX-20111, CXA1019M, CX-20091.

▶ Dimensions

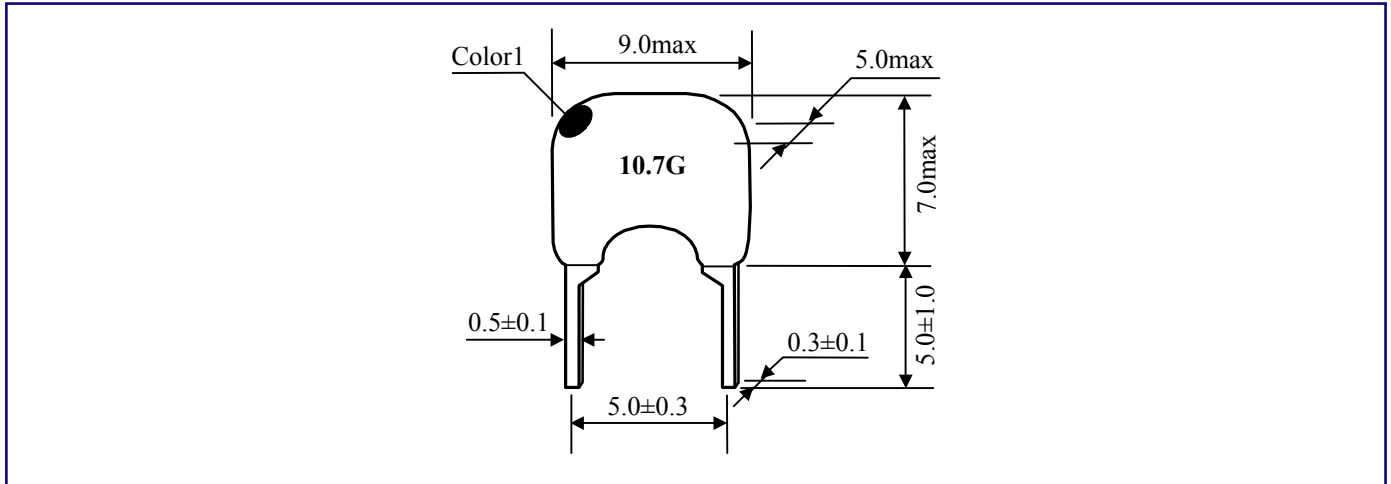

▶ Technical Characteristics

Part Number	Demodulation Output at fo (mv) min	Distortion Factor at fo (%) max	Demodulation 3dB Band Width (kHz) max	Applicable IC
JT10.7MG1	25	1.0	345	CX-2009,CX-20111
JT10.7MG3	650	1.0	±150	TA7303P,TA7130,μPC1028H,A1150
JT10.7MG16	60~90	0.9	300	TA8122AN
JT10.7MG18	60~90	0.9	300	TA8132N
JT10.7MG33	45	0.7	250	TA2007
JT10.7MG80	65	1.0	300	TA2104AFN
JT10.7MG82	90	0.8	320	TA2099N
JT10.7MG92	60	1.0	300	TA2132P
JT10.7MC1	35	1.0	242	CXA1019M,CX-20091

▶ Standard Rule

Center Frequency	Color
D:10.64MHz±30kHz	Black
B:10.67MHz±30kHz	Blue
A:10.70MHz±30kHz	Red
C:10.73MHz±30kHz	Orange
E:10.76MHz±30kHz	White

▶ Test Circuit

JT10.7MG₃

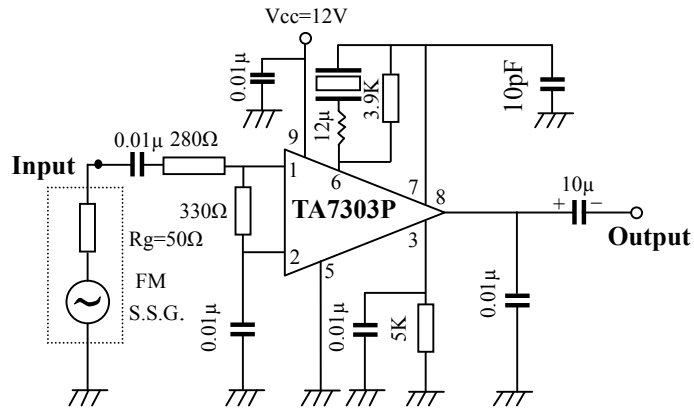

JT10.7MG₁₆

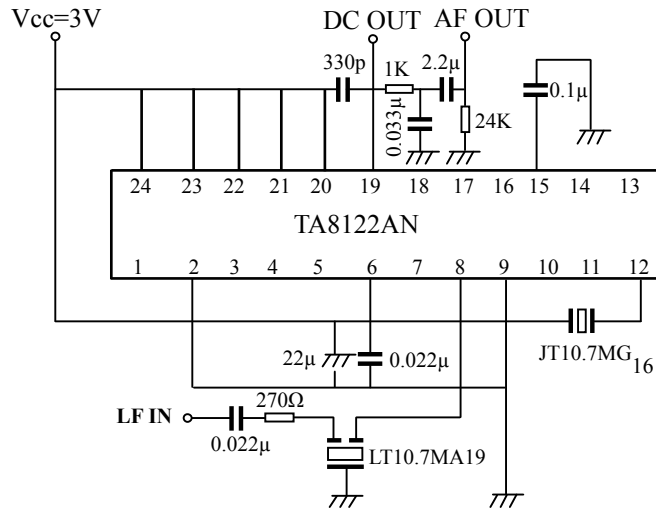

JTCV 10.7MG₁₈

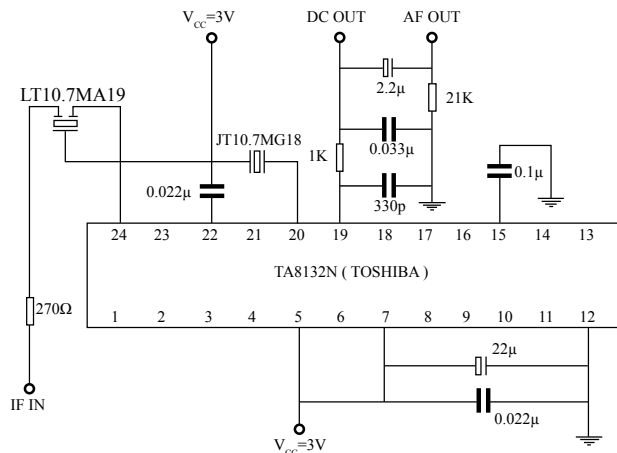

▶ Test Circuit

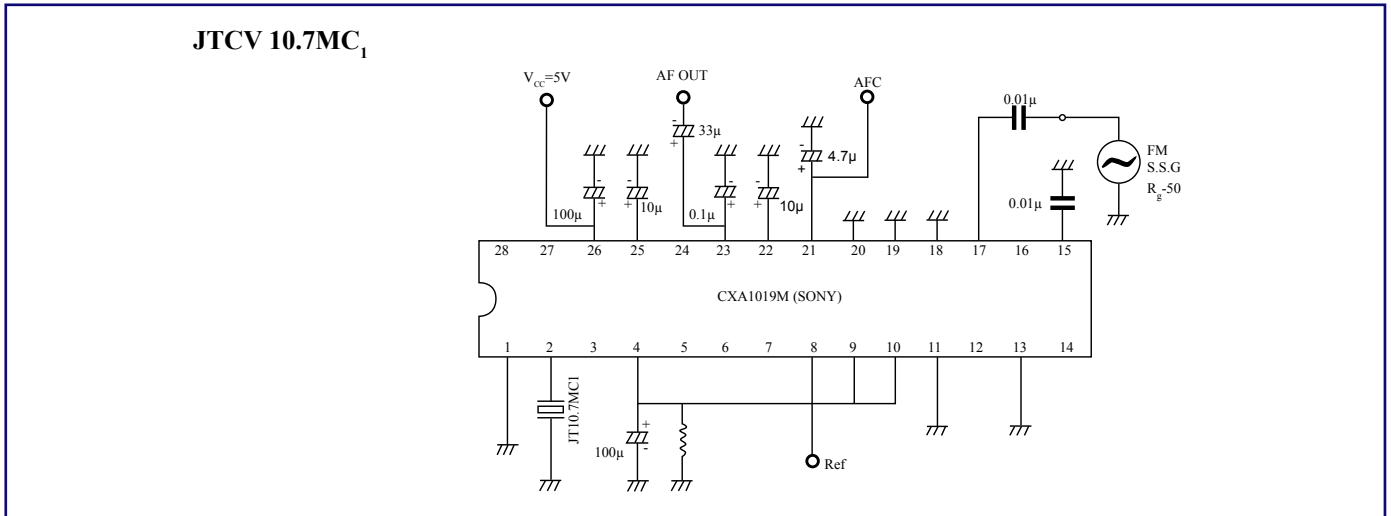

▶ How to Order

JT10.7MG3

A

P

❶

❷

❸

❶ Part Number

❷ Center Frequency color code

Code	Center Frequency color code
A	10.70MHz±30kHz
B	10.67MHz±30kHz
C	10.73MHz±30kHz
D	10.64MHz±30kHz
E	10.76MHz±30kHz

❸ Packaging

Back to 1st Page - Ceramic Discriminator JT107M