

THIS DRAWING IS UNPUBLISHED. RELEASED FOR PUBLICATION 20
 © COPYRIGHT 20 BY TYCO ELECTRONICS CORPORATION. ALL RIGHTS RESERVED.

LOC	DIST	REVISIONS			
P	LTR	DESCRIPTION	DATE	DWN	APVD
FT	0	B	REVISED PER 0G3B-0119-01	24JAN2002	EZ DB

- 1 MATERIALS AND FINISH
HOUSING: PA 6-6, UL 94-V0, COLOR GREEN.
TERMINAL: PHOSPHOR BRONZE, TIN PLATED.
- 2 SUITABLE FOR 1,6-2,4mm PC BOARD THICKNESS.
- 3 NOT CUMULATIVE TOLERANCE.
- 4 P/N FROM 284061-3 TO 2-284061-5 ARE OBTAINED BY ASSEMBLING DIFFERENT MONOLITHIC MODULES CHOSEN AMONG: 284061-2 AND 284061-3, IN ORDER TO REALIZE THE DESIRED NUMBER OF WAYS.
- 5 P/N 2-284061-6 IS OBTAINED BY ASSEMBLING AND GLUING TOGETHER 4 P/N 284061-3 AND 3 P/N 284061-2.

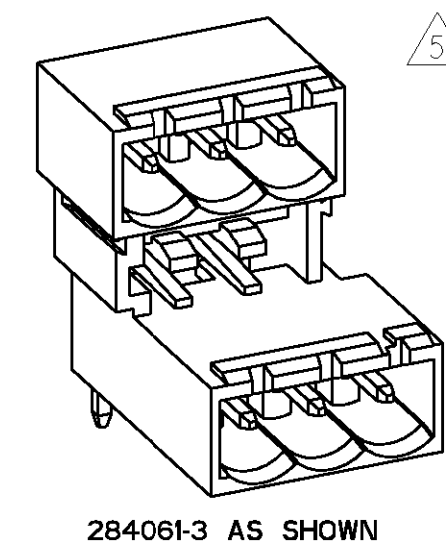
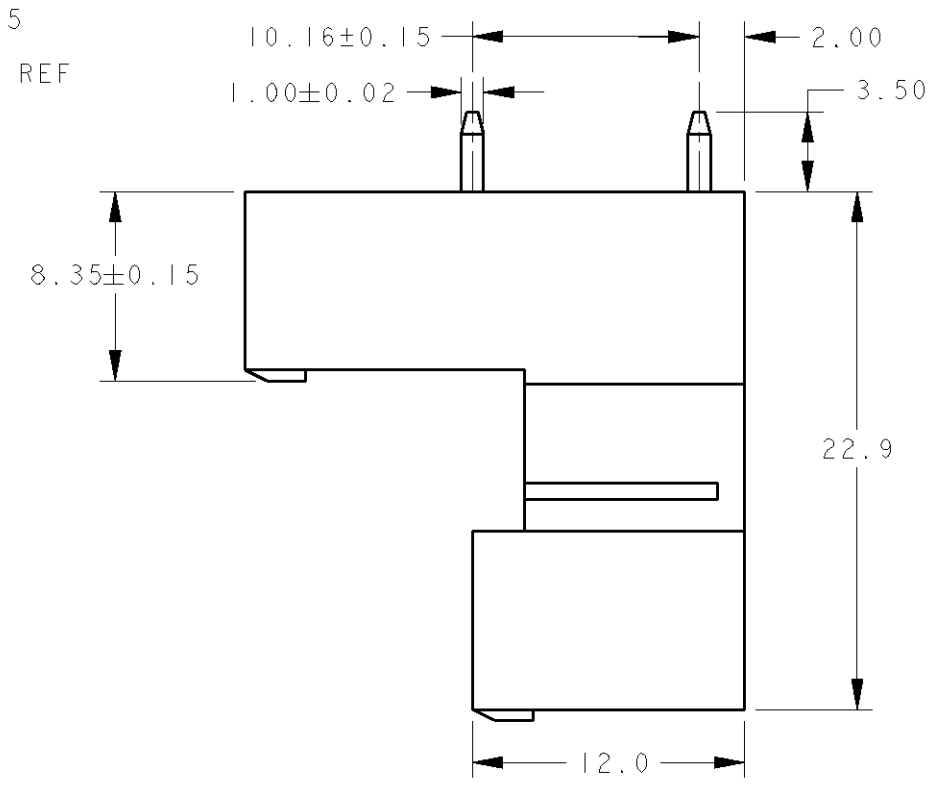
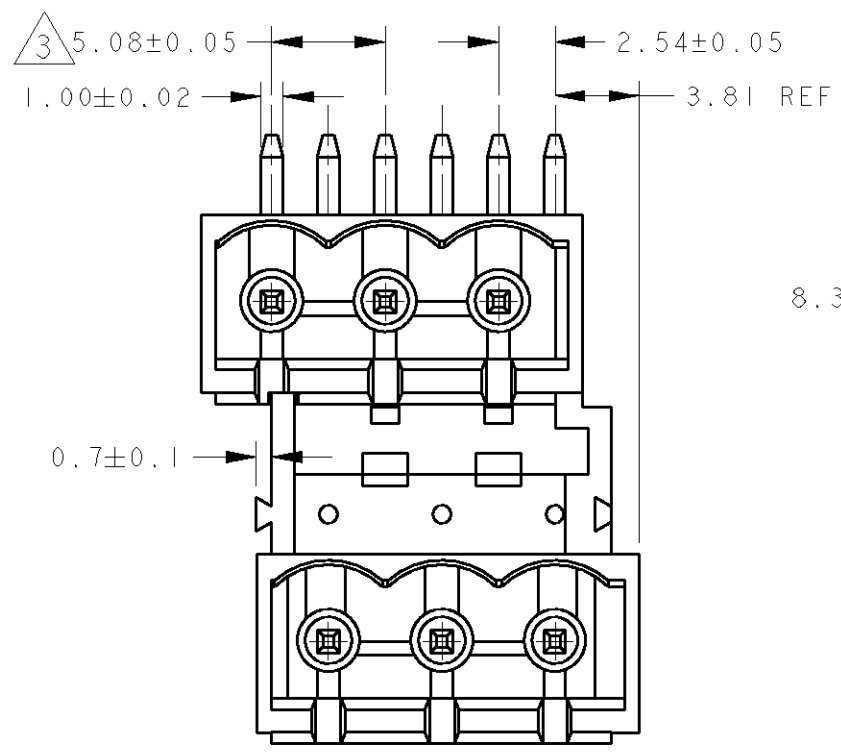
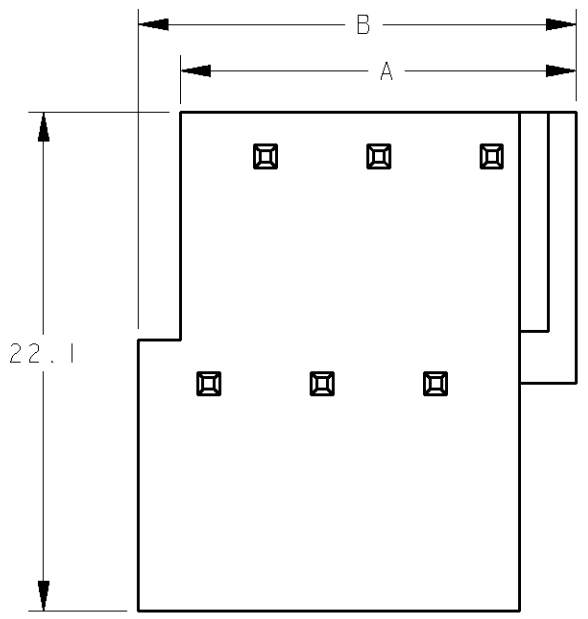

DIM"A"	DIM"B"	N°OF TOTAL POS.	PART NUMBER
83.32	85.86	16	2-284061-6
129.04	131.58	25	2-284061-5
123.96	126.50	24	2-284061-4
118.88	121.42	23	2-284061-3
113.80	116.34	22	2-284061-2
108.72	111.26	21	2-284061-1
103.64	106.18	20	2-284061-0
98.56	101.10	19	1-284061-9
93.48	96.02	18	1-284061-8
88.40	90.94	17	1-284061-7
83.32	85.86	16	1-284061-6
78.24	80.78	15	1-284061-5
73.16	75.70	14	1-284061-4
68.08	70.62	13	1-284061-3
63.00	65.54	12	1-284061-2
57.92	60.46	11	1-284061-1
52.84	55.38	10	1-284061-0
47.76	50.30	9	284061-9
42.68	45.22	8	284061-8
37.60	40.14	7	284061-7
32.52	35.06	6	284061-6
27.44	29.98	5	284061-5
22.36	24.90	4	284061-4
17.28	19.82	3	284061-3
12.20	14.74	2	284061-2

RECOMMENDED PC BOARD LAYOUT

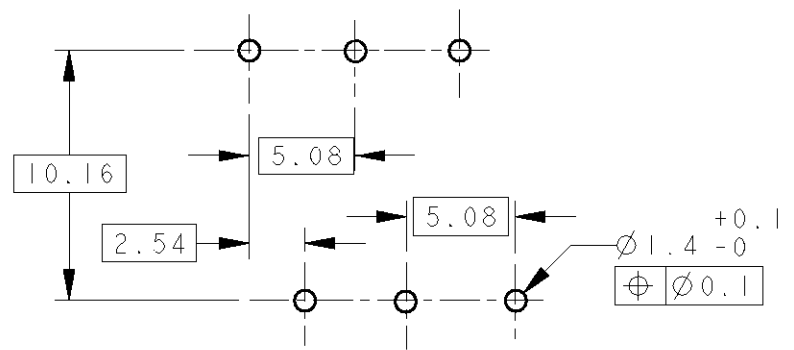

THIS DRAWING IS A CONTROLLED DOCUMENT FOR TYCO ELECTRONICS CORPORATION. IT IS SUBJECT TO CHANGE AND THE CONTROLLING ENGINEERING ORGANIZATION SHOULD BE CONTACTED FOR THE LATEST REVISION.

DIMENSIONS: mm	TOLERANCES UNLESS OTHERWISE SPECIFIED: 0 PLC ±.3 1 PLC ±.25 2 PLC ±.25 3 PLC ±. 4 PLC ±. ANGLES ±2	DWN 24JAN2002 E. ZANOLINI CHK 24JAN2002 E. ZANOLINI APVD 24JAN2002 D. BIEVENOUR	BUCHANAN Tyco Electronics Harrisburg, PA 17105-3608
MATERIAL	FINISH	PRODUCT SPEC -	NAME TERMINAL BLOCK MULTIPLE HEADER, 90° CLOSED ENDS 5.08mm PITCH
		APPLICATION SPEC -	SIZE A3 CAGE CODE 00779 DRAWING NO C=284061 RESTRICTED TO -
		WEIGHT -	SCALE 3:1 SHEET 1 OF 1 REV B

CUSTOMER DRAWING