



### FEATURES

- User-settable, visual alarm function
- Flashing display indicates overcurrent faults
- Measures the true-rms value of complex ac current waveforms
- Includes built-in current transformers
- Ideal for measuring current in sensitive IT applications
- Available in two input ranges: 0-30.0A, and 0 to 50A
- 50A model features convenient split-core CT
- Easy-to-read, red LED display with 0.37"/9.4mm high digits
- Two AC power options: 85-140Vac & 170-264Vac (50/60Hz)
- 2000V isolation between ac supply and load conductor

Murata Power Solutions' ACA-20RM-ALM Series digital ac ammeters accurately display the true-rms value of non-sinusoidal ac currents and provide a user-settable, over current alarm function. When the preset over current level is exceeded, the LED display continuously flashes from high to low intensity. All models are totally self-contained—no other user-supplied components are required. A built-in current transformer greatly simplifies most ac ammeter applications: just pass the load conductor through the built-in current transformer, apply ac power, and the ammeter is fully operational.

Two input ranges are available: 0-30.0 Amps, or 0 to 50.0 Amps, both with 0.1A resolution. The 50 Amp model features a convenient split-core type current transformer which can be clamped around insulated live conductors. Two power supply options are available: 85-140V (47-63Hz), and 170-264V (47-63Hz). Power consumption from a nominal 120V or 220V ac supply is less than 50mA. Super-stable components and an rms-to-dc converter circuit combine to achieve excellent performance when measuring the complex, non-sinusoidal, ac currents found in today's computer/telecom equipment.

All ACA-20RM-ALM Series true-rms ammeters feature full-size, 0.37" (9.4mm) high, 3½ digit, bright red LED-displays and a built-in bezel/filter assembly that includes metal fasteners. They are also panel cutout compatible with MPS's DMS-20RM Series of rms-reading ac voltage monitors, making ACA-20RM-ALM ammeters the ideal upgrade for today's sophisticated instrumentation.

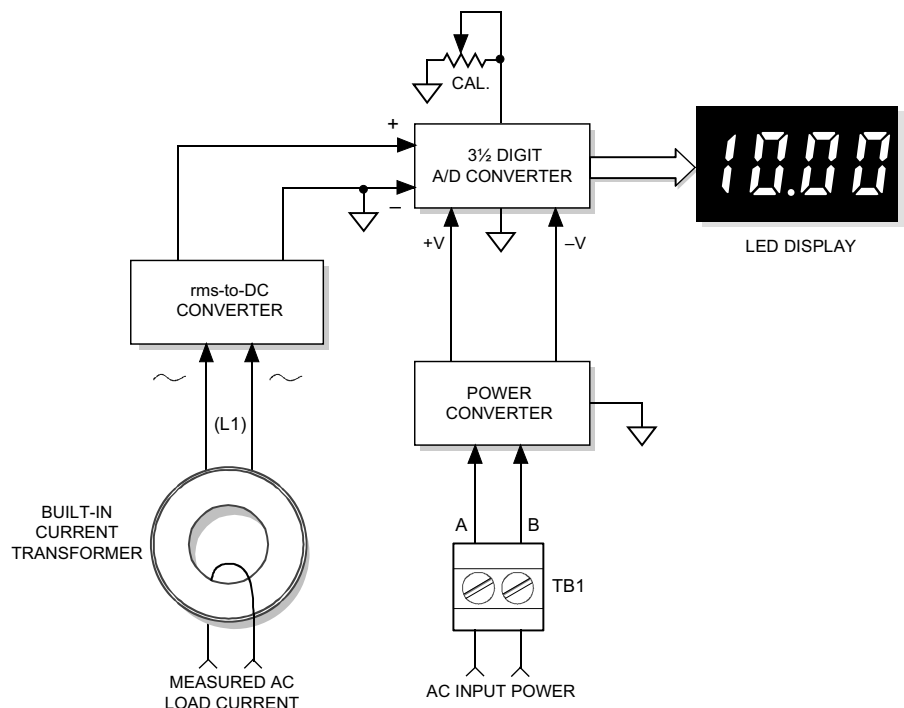

Figure 1. ACA-20RM-ALM Series simplified schematic



### Performance/Functional Specifications

Typical at T<sub>A</sub> = +25°C, unless otherwise noted.

Rated Full-Scale Current ①	Min.	Typ.	Max.	Units
ACA-20RM-4-ACX-RL-ALM	—	—	50.0	Amperes
ACA-20RM-5-ACX-RL-ALM	—	—	30.0	Amperes
Overcurrent Rating ②	1.5 x Rated Full-Scale Current			
<b>Performance</b>				
Sampling Rate	2.5 Samples per second			
Accuracy ③	±0.4%FS ±3 Counts with 60Hz Sine-Wave Input			
Measurement Type	rms Responding, Crest Factors of 1-5			
Temperature Drift (0 to 60 °C)	—	±0.2	±0.4	Counts/°C
Zero-Current Reading (within 30 sec.)	-001	000	001	Counts
Dielectric Withstanding Voltage	2000	—	—	Vdc
<b>Power Supply Voltage</b>				
ACA-20RM-X-AC3-RL-ALM	85	120	140	Vac/47-63Hz
ACA-20RM-X-AC4-RL-ALM	170	220	264	Vac/47-63Hz
<b>Power Supply Current ④</b>				
ACA-20RM-X-AC3-RL-ALM	—	30	50	mA/47-63Hz
ACA-20RM-X-AC4-RL-ALM	—	30	50	mA/47-63Hz
<b>Alarm Function</b>				
Display indication	Flashing Display with actual current reading and display intensity change			
<b>Settable range</b>				
ACA-20RM-4-ACX-RL-ALM	13	45	50	Amps
ACA-20RM-5-ACX-RL-ALM	8	24	30	Amps
<b>Power Supply Terminal Block</b>				
Wire Size	16-22AWG, Solid or stranded			
Insulation Strip Length	0.250 inches			
Screw Tightening Torque	3.6 pounds-inches (0.4Nm)			
Rated Voltage	310Vac			
<b>Display</b>				
Display Type and Size	3½ Digit Red LED, 0.37"/9.4mm High			
Overrange Indication	"1 ___"			
Decimal Point	Fixed, model dependent (see full-scale input current)			
<b>Physical/Environmental</b>				
Operating Temperature	0	—	+60	°C
Storage Temperature	-40	—	+75	°C
Humidity (non-condensing)	0	—	85	%
Dimensions	Model dependent, see page 4 & 5			
<b>Weight</b>				
ACA-20RM-4-XXX-XX-ALM	1.5 Ounces (43 grams) nominal			
ACA-20RM-5-XXX-XX-ALM	2.1 Ounces (60 grams) nominal			

- ① Specified full-scale currents are those passing through the ammeter's built-in current transformer's primary load-circuit. See Notes 2 and 3 below for additional model-specific information.
- ② The overcurrent rating of 1.5 x the rated full-scale current is a continuous rating and applies to the current passing through the built in current transformer only, it does not apply to any external circuit-wiring or external loads. Accuracy is guaranteed up to the rated current level.
- ③ Specified accuracy applies to inputs with crest factors (CF) up to 2.0, where CF = Vpeak/Vrms. Crest factors of 2 to 5 introduce an additional error of ±3% of full scale. Ammeters are calibrated with a near full-scale 60Hz sine-wave current flowing through the ammeter's built-in CT.
- ④ All specified maximum power supply currents are steady state; larger surge currents can occur at initial application of line power.

### Ordering Information

<b>ACA-20RM-4-AC3-RL-ALM-C</b>	50.0A Range (split-core CT), 85-140Vac power
<b>ACA-20RM-4-AC4-RL-ALM-C</b>	50.0A Range (split core CT), 170-264Vac power
<b>ACA-20RM-5-AC3-RL-ALM-C</b>	30.0A Range, 85-140Vac power
<b>ACA-20RM-5-AC4-RL-ALM-C</b>	30.0A Range, 170-264Vac power

### TECHNICAL NOTES

**IMPORTANT! To ensure safe and reliable operation, ACA-20RM-ALM ammeters must be installed and serviced by qualified technical personnel. Contact Murata Power Solutions if there is any doubt regarding ammeter setup, installation, or operation.**

- 1. Measurement Type:** ACA-20RM-ALM ac ammeters employ a true-rms input circuit to measure current flowing through L1. Stated accuracy specifications are measured using a sine-wave current at, or close to, the ammeter's full-scale input range, at nominal line frequency of 60Hz.
- 2. Calibration (Potentiometer R7):** Periodic recalibration of ACA-20RM-ALM ammeters is not required under normal, indoor operating environments. If user calibration is necessary, it must be performed by qualified technical personnel. Calibration is performed with potentially lethal voltages applied to the ACA-20RM-ALM and its associated wiring. A plastic, fully-insulated adjusting tool must be used to access the calibration potentiometer R7 located on the back of the ammeter (see 'Mechanical Specifications' section). Contact MPS if additional information is required regarding calibration, setup, or any other technical issue pertaining to ACA-20RM-ALM ammeters.
- 3. Overcurrent Alarm Setup and Adjustment (Potentiometer R3):** ACA-20RM-ALM ammeters feature a user-settable, overcurrent visual alarm indication which can be used to alert operators that a load circuit breaker or fuse is approaching an overload condition. When the load current sensed by L1 exceeds this preset level, the ammeter's LED display will flash from normal intensity to dim intensity at rate of approximately 1.5 times per second.

As shown in Figure 3, the alarm circuit consists of jumper JP1, and adjustment potentiometer R3. As shipped, R3 is factory set to trip when the load current is approximately 24 Amps for 30A models, and approximately 45 Amps for 50A models. When R3 is set to its maximum clockwise position, the alarm indication will not activate until the load current flowing through L1 exceeds the maximum rating of the ammeter, i.e., above 30.0A, or above 50.0A, depending on the model.

To adjust the overcurrent alarm set-point level:

- A. Turn off power to the ACA-20RM-ALM (i.e., the power source connected to TB1).
- B. Carefully remove the shorting jumper across JP1 from its 'normal operation position' across terminals 2 and 3 and place it across JP1 terminals 1 and 2.
- C. Re-apply power to TB1 and, using a plastic insulated adjusting tool, adjust R3 so the ammeter's display shows the desired overcurrent trip level in Amps.
- D. Turn off power to the ACA-20RM-ALM and return JP1's shorting jumper back to its 'normal operation position' across terminals 2 and 3. Re-apply power to TB1 to resume normal operation. If possible, after the ammeter is re-configured for normal operation, the load current should be slowly increased to verify the visual alarm operates when the load current exceeds the preset level.

Please note, the load circuit does not need to be turned off to adjust the overcurrent alarm set point. Current flowing through L1 while JP1 is across terminals 1 and 2 will not be measured. Once tripped, the alarm set point function has a hysteresis of approximately 0.5A.

The overcurrent alarm function can also be adjusted with JP1 in its normal operation position if the desired alarm overcurrent-level is actually flowing through L1 (i.e., with a live load). For example, with a 20 Amp load current flowing through L1, and with JP1 in its normal operation position, slowly adjust R3 until the display starts flashing on and off. Using this "live load" adjustment method eliminates the need to turn off power to TB1 or reconfiguring JP1.

- 4. Wire Gauges and Fusing:** Wires specified in the Functional Specifications section must be used for making connections to ACA-20RM-ALM Series ammeters. All power-supply and load wiring must be rated for the supply voltages and currents they will conduct and must comply with any code or application-mandated requirements pertaining to the user's specific installation.

The supply wires connected to both the ammeter and the load must be fused according to the current rating of the wire gauge being used, in accordance with applicable regulatory codes. Also, wire insulation should be stripped to within +/-10% of the stated dimensions, and wires should be inserted into TB1 such that their insulation is not pinched by the screw terminal. TB1 is to be used only for powering the meter's internal circuitry, it must not be used to supply current to external loads.

All models draw minimal steady-state supply currents (50mA max.), and in most applications, they can be fused according to the supply wire's maximum amperage rating. However, these products can draw significantly higher surge currents for brief periods when the ac line voltage is initially applied.

- 5. AC Supply Polarity and Grounding:** The two supply inputs, TB1-A and TB1-B, on ACA-20RM-ALM ammeters are not in themselves polarity sensitive, that is, they have no internal "AC LO" or "AC HI" designations. ACA-20RM-ALM ammeters do not include or require a connection to earth/chassis ground.

- 6. Connector Torque Ratings:** It is important to tighten TB1's, screw-terminals to their rated torque specification of 3.6 pound-inches (0.4Nm). Proper tightening will minimize connector losses and ensure safe, reliable operation.
- 7. Isolation:** The built-in current transformer L1 provides a minimum of 2000Vdc isolation between the load conductor and the ammeter's supply voltage connected to TB1.
- 8. Split-Core CT (Clamp-on) Models:** Both 50A models feature a split-core current transformer that can be clamped around a properly insulated live conductor without having to disconnect or remove power from the load circuit. This live-connection capability can only be used if the load's power source is electrically isolated (see technical note 7) from the ammeter's own power source that's connected to TB1. The ammeter's ac power supply must always be deenergized before making connections to TB1. Refer to the 'Panel Installation' section of this data sheet for additional information.

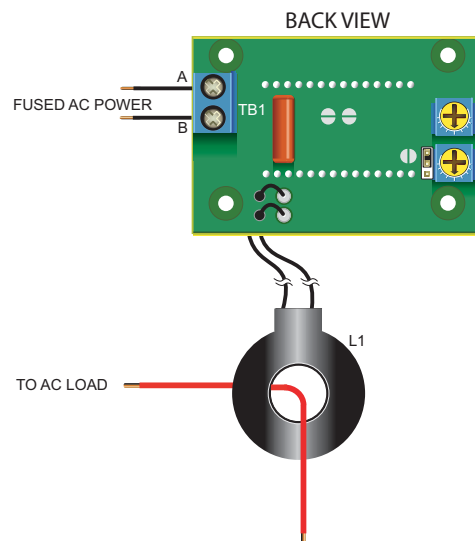

Figure 2. Typical wiring diagram

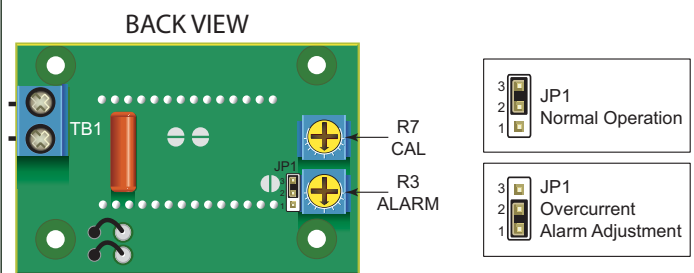

Figure 3. Alarm circuit component location

### PANEL INSTALLATION

All connections to ACA-20RM-ALM Series ammeters must be made after the ammeter is securely attached to the panel and with all associated load and supply voltages de-energized (off), using extreme caution and observing all safety measures applicable to the user's installation.

Care should be exercised when passing conductors through the ammeter's built-in current transformer L1. The installed wire-positions should be such that minimal mechanical forces are applied to L1, TB1, or to the ammeter itself. In high-vibration environments, it is strongly recommended that adequate strain reliefs be used for all wiring.

Using Figure 4 as a guide, carefully insert the bezel/color filter assembly into the panel opening. From the rear of the panel, install the four round

plastic standoffs over the bezel's threaded studs. Install the ACA-20RM-ALM pc-board assembly as shown and then attach and securely tighten all four hex nuts. Use only the factory-supplied hardware as the use of substitute hardware could result in an unsafe installation and/or adversely affect the reliability of the ammeter.

The recommended range of panel thickness that can be used with the supplied hardware is 0.040 inches (1.0mm) to 0.125 inches (3.2mm). Panel thickness outside of this range will require additional user-supplied hardware or modifications.

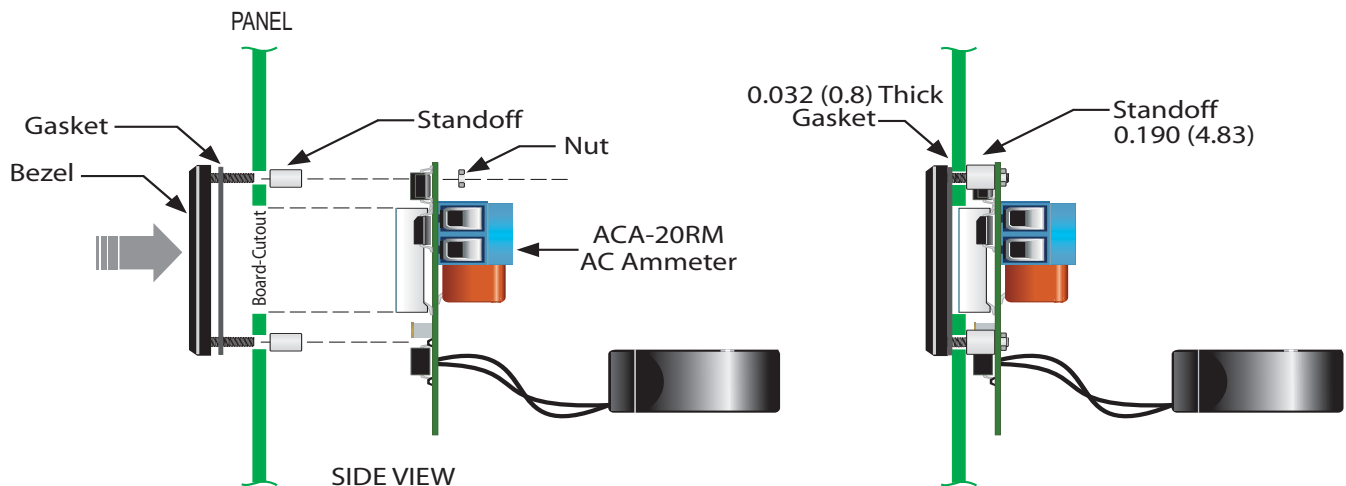
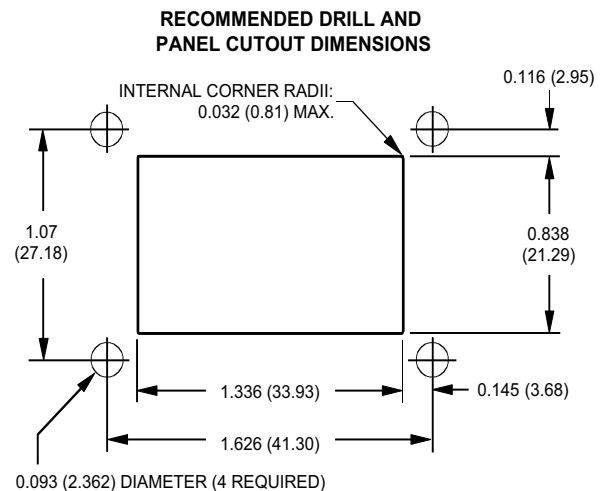
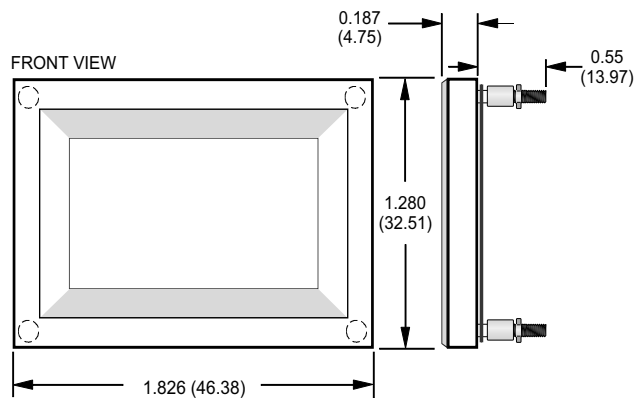
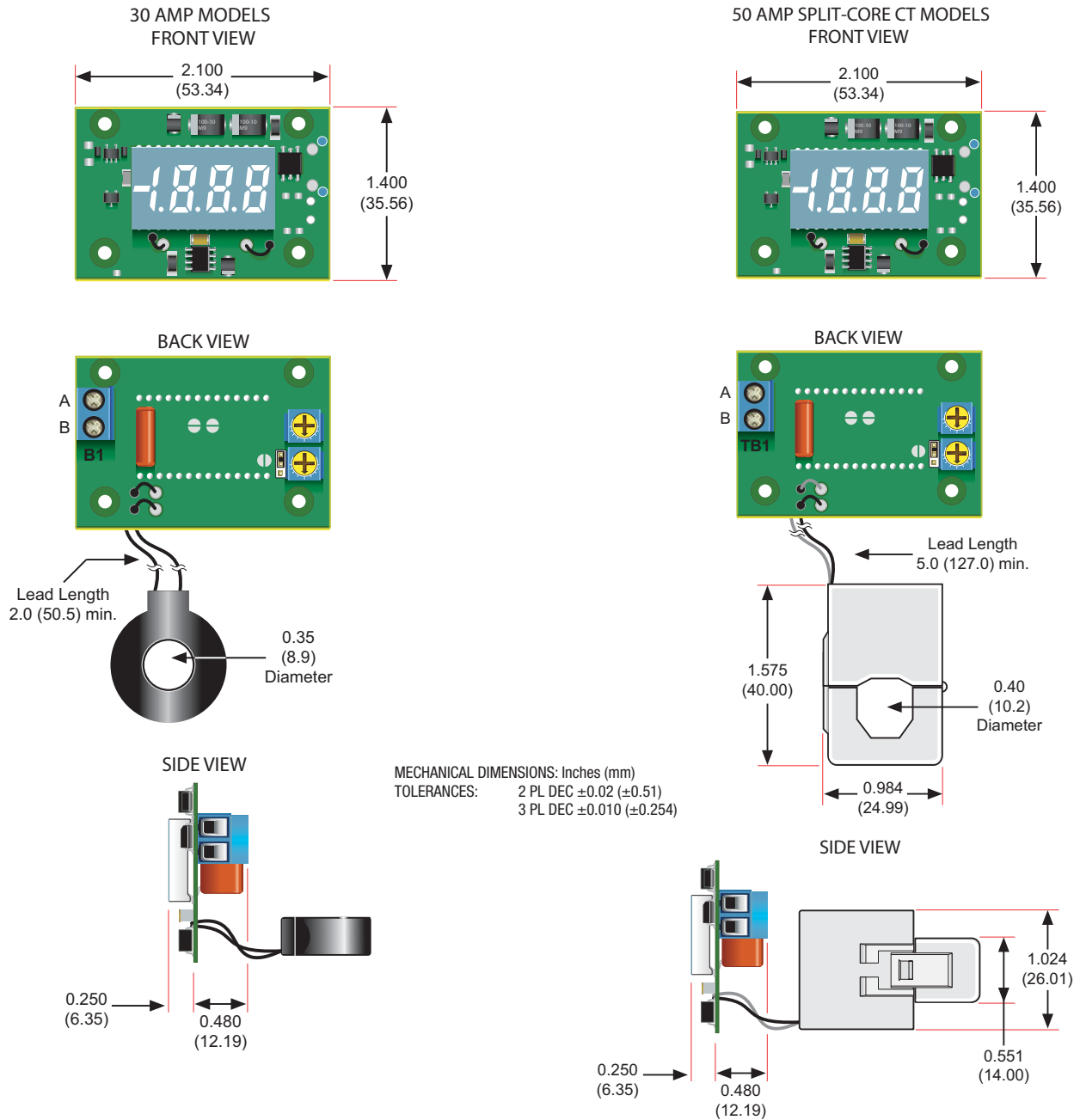

Figure 4. Panel Installation

### BEZEL AND PANEL CUTOUT



## MECHANICAL SPECIFICATIONS



Murata Power Solutions, Inc.  
 11 Cabot Boulevard, Mansfield, MA 02048-1151 U.S.A.  
 Tel: (508) 339-3000 (800) 233-2765 Fax: (508) 339-6356  
 www.murata-ps.com email: sales@murata-ps.com ISO 9001 and 14001 REGISTERED

01/27/09  
 Murata Power Solutions, Inc. makes no representation that the use of its products in the circuits described herein, or the use of other technical information contained herein, will not infringe upon existing or future patent rights. The descriptions contained herein do not imply the granting of licenses to make, use, or sell equipment constructed in accordance therewith. Specifications are subject to change without notice.  
 © 2008 Murata Power Solutions, Inc.

- USA:** Mansfield (MA), Tel: (508) 339-3000, email: sales@murata-ps.com
- Canada:** Toronto, Tel: (866) 740-1232, email: toronto@murata-ps.com
- UK:** Milton Keynes, Tel: +44 (0)1908 615232, email: mk@murata-ps.com
- France:** Montigny Le Bretonneux, Tel: +33 (0)1 34 60 01 01, email: france@murata-ps.com
- Germany:** München, Tel: +49 (0)89-544334-0, email: munich@murata-ps.com
- Japan:** Tokyo, Tel: 3-3779-1031, email: sales\_tokyo@murata-ps.com  
 Osaka, Tel: 6-6354-2025, email: sales\_osaka@murata-ps.com
- China:** Shanghai, Tel: +86 215 027 3678, email: shanghai@murata-ps.com  
 Guangzhou, Tel: +86 208 221 8066, email: guangzhou@murata-ps.com
- Singapore:** Parkway Centre, Tel: +65 6348 9096, email: singapore@murata-ps.com