



# PCF8576D

Universal LCD driver for low multiplex rates

Rev. 7 — 18 December 2008

Product data sheet

## 1. General description

The PCF8576D is a peripheral device which interfaces to almost any Liquid Crystal Display (LCD) with low multiplex rates. It generates the drive signals for any static or multiplexed LCD containing up to four backplanes and up to 40 segments. It can be easily cascaded for larger LCD applications. The PCF8576D is compatible with most microprocessors or microcontrollers and communicates via a two-line bidirectional I<sup>2</sup>C-bus. Communication overheads are minimized by a display RAM with auto-incremented addressing, by hardware subaddressing and by display memory switching (static and duplex drive modes).

AEC-Q100 compliant (PCF8576DH/2) for automotive applications.

## 2. Features

- Single chip LCD controller and driver
- Selectable backplane drive configuration: static or 2, 3, 4 backplane multiplexing
- Selectable display bias configuration: static,  $\frac{1}{2}$  or  $\frac{1}{3}$
- Internal LCD bias generation with voltage-follower buffers
- 40 segment drives:
  - ◆ Up to twenty 7-segment numeric characters
  - ◆ Up to ten 14-segment alphanumeric characters
  - ◆ Any graphics of up to 160 elements
- 40 × 4-bit RAM for display data storage
- Auto-incremented display data loading across device subaddress boundaries
- Display memory bank switching in static and duplex drive modes
- Versatile blinking modes
- Independent supplies possible for LCD and logic voltages
- Wide power supply range: from 1.8 V to 5.5 V
- Wide logic LCD supply range:
  - ◆ From 2.5 V for low-threshold LCDs
  - ◆ Up to 6.5 V for guest-host LCDs and high-threshold twisted nematic LCDs
- Low power consumption
- 400 kHz I<sup>2</sup>C-bus interface
- May be cascaded for large LCD applications (up to 2560 elements possible)
- No external components
- Compatible with chip-on-glass and chip-on-board technology
- Manufactured in silicon gate CMOS process

### 3. Ordering information

Table 1. Ordering information

| Type number     | Package       |   |               |
|-----------------|---------------|---|---------------|
|                 | Name          | Description   | Version       |
| PCF8576DH/2     | TQFP64        | plastic thin quad flat package, 64 leads;<br>body 10 × 10 × 1.0 mm        | SOT357-1      |
| PCF8576DT/2     | TSSOP56       | plastic thin shrink small outline package, 56 leads;<br>body width 6.1 mm | SOT364-1      |
| PCF8576DU/DA/2  | PCF8576DU/DA  | wire bond die; 59 bonding pads; 2.26 × 2.01 × 0.38 mm <sup>[1]</sup>      | PCF8576DU/DA  |
| PCF8576DU/2DA/2 | PCF8576DU/2DA | bare die; 59 bumps; 2.26 × 2.01 × 0.40 mm <sup>[1]</sup>                  | PCF8576DU/2DA |

[1] Chips in tray.

[1] Chips with bumps in tray.

### 4. Marking

Table 2. Marking codes

| Type number     | Marking code |
|-----------------|--------------|
| PCF8576DH/2     | PCF8576DH    |
| PCF8576DT/2     | PCF8576DT    |
| PCF8576DU/DA/2  | PC8576D-2    |
| PCF8576DU/2DA/2 | PC8576D-2    |



## 6. Pinning information

### 6.1 Pinning

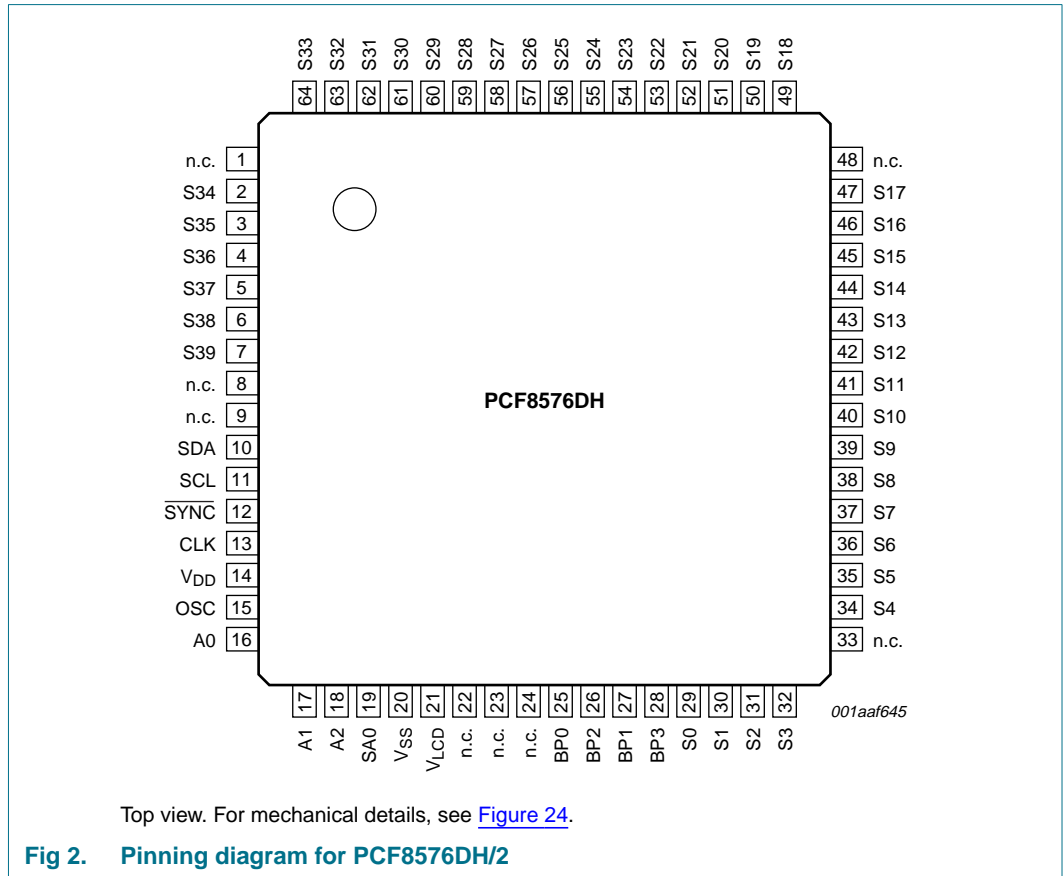

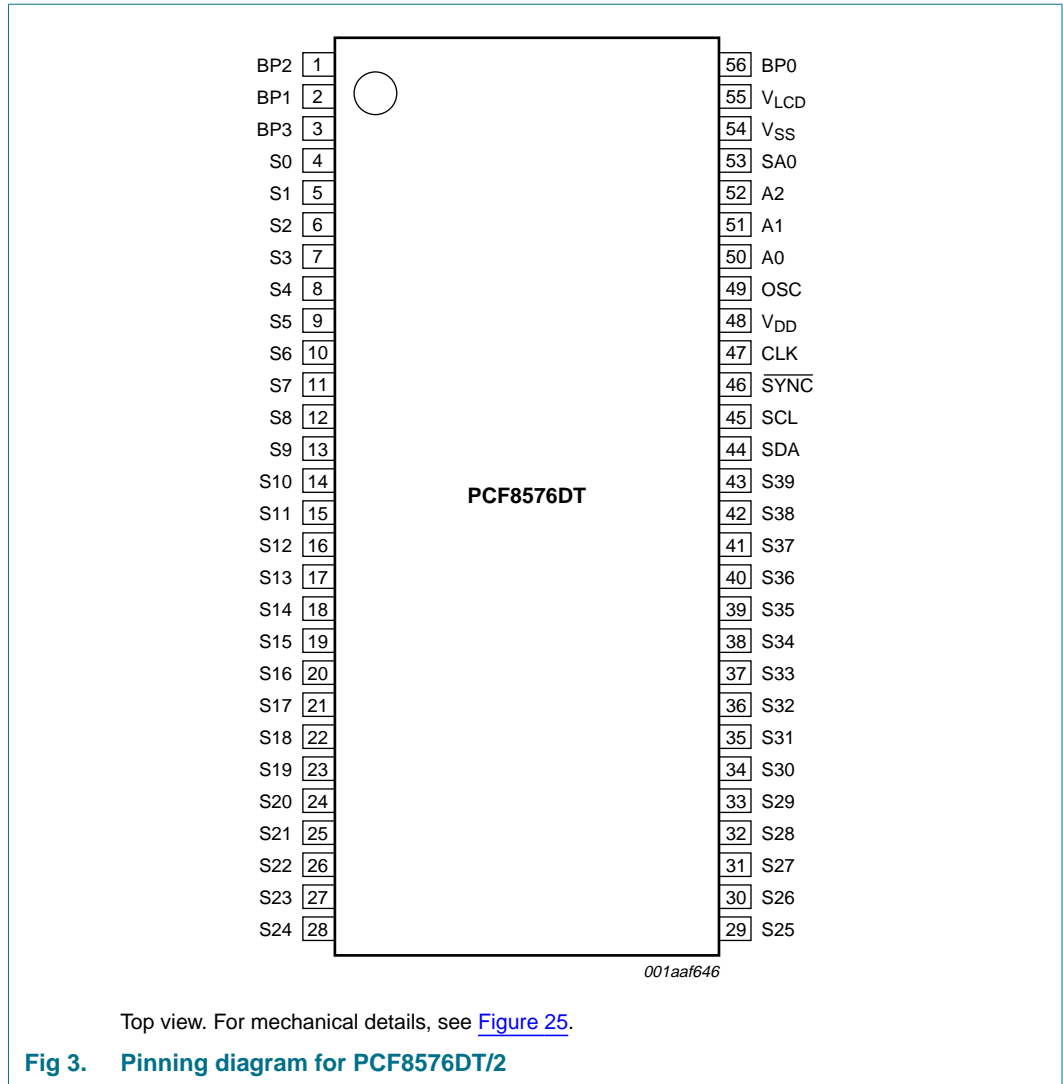

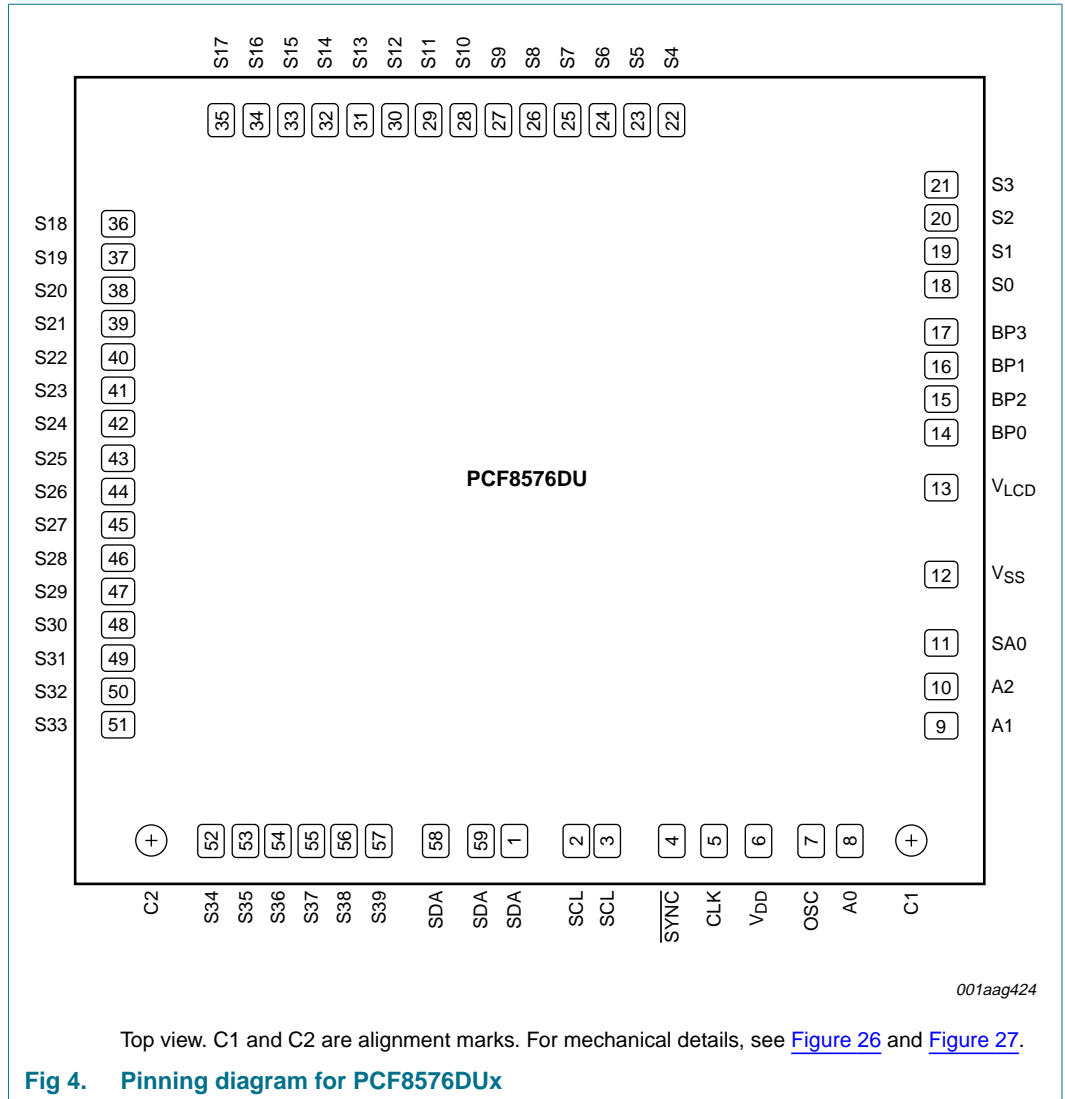

## 6.2 Pin description

Table 3. Pin description

| Symbol                   | Pin                                     |             |                   | Description                                       |
|--------------------------|---|-------------|-------------------|---|
|                          | PCF8576DH/2                             | PCF8576DT/2 | PCF8576DUx        |   |
| SDA                      | 10                                      | 44          | 1, 58 and 59      | I <sup>2</sup> C-bus serial data input and output |
| SCL                      | 11                                      | 45          | 2 and 3           | I <sup>2</sup> C-bus serial clock input           |
| CLK                      | 13                                      | 47          | 5                 | external clock input or output                    |
| V <sub>DD</sub>          | 14                                      | 48          | 6                 | supply voltage                                    |
| $\overline{\text{SYNC}}$ | 12                                      | 46          | 4                 | cascade synchronization input or output           |
| OSC                      | 15                                      | 49          | 7                 | internal oscillator enable input                  |
| A0 to A2                 | 16 to 18                                | 50 to 52    | 8 to 10           | subaddress inputs                                 |
| SA0                      | 19                                      | 53          | 11                | I <sup>2</sup> C-bus address input; bit 0         |
| V <sub>SS</sub>          | 20                                      | 54          | 12 <sup>[1]</sup> | ground supply voltage                             |
| V <sub>LCD</sub>         | 21                                      | 55          | 13                | LCD supply voltage                                |
| BP0, BP2,<br>BP1, BP3    | 25 to 28                                | 56, 1, 2, 3 | 14 to 17          | LCD backplane outputs                             |
| S0 to S39                | 29 to 32, 34 to 47,<br>49 to 64, 2 to 7 | 4 to 43     | 18 to 57          | LCD segment outputs                               |
| n.c.                     | 1, 8, 9, 22 to 24,<br>33, 48            | -           | -                 | not connected                                     |

[1] The substrate (rear side of the die) is wired to V<sub>SS</sub> but should not be electrically connected.

## 7. Functional description

The PCF8576D is a versatile peripheral device designed to interface any microprocessor or microcontroller with a wide variety of LCDs. It can directly drive any static or multiplexed LCD containing up to four backplanes and up to 40 segments.

The possible display configurations of the PCF8576D depend on the number of active backplane outputs required. A selection of display configurations is shown in [Table 4](#). All of these configurations can be implemented in the typical system shown in [Figure 5](#).

Table 4. Display configurations

| Number of: |          | 7-segment numeric |                   | 14-segment numeric |                   | Dot matrix        |
|------------|----------|-------------------|-------------------|--------------------|-------------------|-------------------|
| Backplanes | Segments | Digits            | Indicator symbols | Characters         | Indicator symbols |                   |
| 4          | 160      | 20                | 20                | 10                 | 20                | 160 dots (4 × 40) |
| 3          | 120      | 15                | 15                | 8                  | 8                 | 120 dots (3 × 40) |
| 2          | 80       | 10                | 10                | 5                  | 10                | 80 dots (2 × 40)  |
| 1          | 40       | 5                 | 5                 | 2                  | 12                | 40 dots (1 × 40)  |

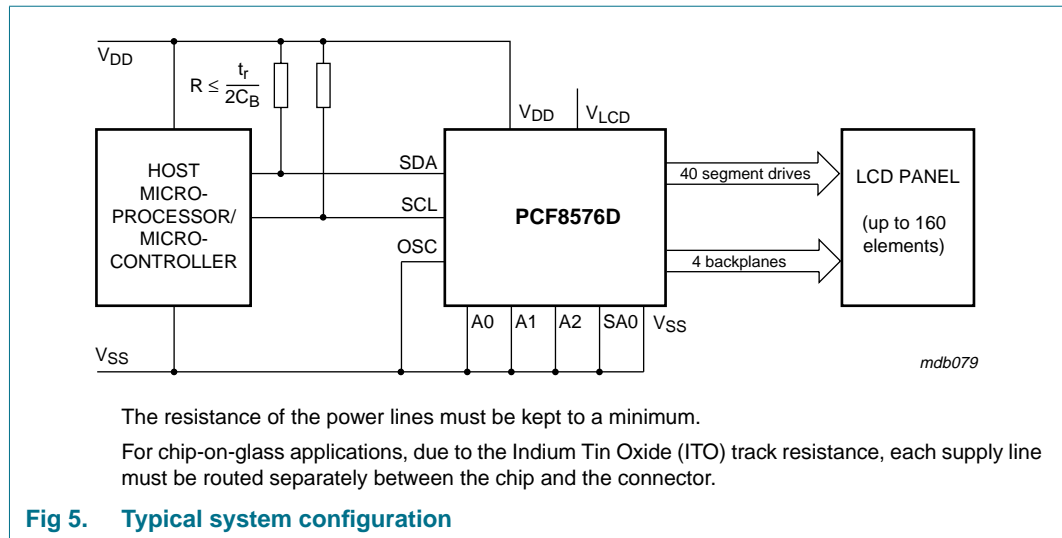

The host microprocessor or microcontroller maintains the 2-line I<sup>2</sup>C-bus communication channel with the PCF8576D. The internal oscillator is enabled by connecting pin OSC to pin V<sub>SS</sub>. The appropriate biasing voltages for the multiplexed LCD waveforms are generated internally. The only other connections required to complete the system are to the power supplies (V<sub>DD</sub>, V<sub>SS</sub> and V<sub>LCD</sub>) and the LCD panel chosen for the application.

### 7.1 Power-on reset

At power-on the PCF8576D resets to the following starting conditions:

- All backplane outputs are set to V<sub>LCD</sub>
- All segment outputs are set to V<sub>LCD</sub>
- The selected drive mode is: 1:4 multiplex with 1/3 bias
- Blinking is switched off
- Input and output bank selectors are reset
- The I<sup>2</sup>C-bus interface is initialized
- The data pointer and the subaddress counter are cleared
- Display is disabled

Data transfers on the I<sup>2</sup>C-bus must be avoided for 1 ms following power-on to allow the reset action to complete.

### 7.2 LCD bias generator

Fractional LCD biasing voltages are obtained from an internal voltage divider consisting of three impedances connected in series between V<sub>LCD</sub> and V<sub>SS</sub>. The middle resistor can be bypassed to provide a 1/2 bias voltage level for the 1:2 multiplex configuration. The LCD voltage can be temperature compensated externally using the supply to pin V<sub>LCD</sub>.



### 7.3 LCD voltage selector

The LCD voltage selector coordinates the multiplexing of the LCD in accordance with the selected LCD drive configuration. The operation of the voltage selector is controlled by the mode-set command (see [Section 7.17](#)) from the command decoder. The biasing configurations that apply to the preferred modes of operation, together with the biasing characteristics as functions of  $V_{LCD}$  and the resulting discrimination ratios (D), are given in [Table 5](#).

**Table 5. Discrimination ratios**

| LCD drive mode | Number of: |        | LCD bias configuration | $\frac{V_{off(RMS)}}{V_{LCD}}$ | $\frac{V_{on(RMS)}}{V_{LCD}}$ | $D = \frac{V_{on(RMS)}}{V_{off(RMS)}}$ |
|----------------|------------|--------|------------------------|--------------------------------|-------------------------------|--|
|                | Backplanes | Levels |                        |                                |                               |  |
| static         | 1          | 2      | static                 | 0                              | 1                             | $\infty$                               |
| 1:2 multiplex  | 2          | 3      | $\frac{1}{2}$          | 0.354                          | 0.791                         | 2.236                                  |
| 1:2 multiplex  | 2          | 4      | $\frac{1}{3}$          | 0.333                          | 0.745                         | 2.236                                  |
| 1:3 multiplex  | 3          | 4      | $\frac{1}{3}$          | 0.333                          | 0.638                         | 1.915                                  |
| 1:4 multiplex  | 4          | 4      | $\frac{1}{3}$          | 0.333                          | 0.577                         | 1.732                                  |

A practical value for  $V_{LCD}$  is determined by equating  $V_{off(RMS)}$  with a defined LCD threshold voltage ( $V_{th}$ ), typically when the LCD exhibits approximately 10 % contrast. In the static drive mode a suitable choice is  $V_{LCD} > 3V_{th}$ .

Multiplex drive modes of 1:3 and 1:4 with  $\frac{1}{2}$  bias are possible but the discrimination and hence the contrast ratios are smaller.

Bias is calculated by  $\frac{1}{1+a}$ , where the values for a are

a = 1 for  $\frac{1}{2}$  bias

a = 2 for  $\frac{1}{3}$  bias

The RMS on-state voltage ( $V_{on(RMS)}$ ) for the LCD is calculated with the equation

$$V_{on(RMS)} = V_{LCD} \sqrt{\frac{\frac{1}{n} + \left[ (n-1) \times \left( \frac{1}{1+a} \right) \right]^2}{n}} \tag{1}$$

where  $V_{LCD}$  is the resultant voltage at the LCD segment and where the values for n are

n = 1 for static mode

n = 2 for 1:2 multiplex

n = 3 for 1:3 multiplex

n = 4 for 1:4 multiplex

The RMS off-state voltage ( $V_{off(RMS)}$ ) for the LCD is calculated with the equation:

$$V_{off(RMS)} = V_{LCD} \sqrt{\frac{a^2 - (2a+n)}{n \times (1+a)^2}} \tag{2}$$

Discrimination is the ratio of  $V_{on(RMS)}$  to  $V_{off(RMS)}$  and is determined from the equation:

$$\frac{V_{on(RMS)}}{V_{off(RMS)}} = \sqrt{\frac{(a+1)^2 + (n-1)}{(a-1)^2 + (n-1)}} \quad (3)$$

Using [Equation 3](#), the discrimination for an LCD drive mode of 1:3 multiplex with  $\frac{1}{2}$  bias is  $\sqrt{3} = 1.732$  and the discrimination for an LCD drive mode of 1:4 multiplex with  $\frac{1}{2}$  bias is  $\frac{\sqrt{21}}{3} = 1.528$ .

The advantage of these LCD drive modes is a reduction of the LCD full scale voltage  $V_{LCD}$  as follows:

- 1:3 multiplex ( $\frac{1}{2}$  bias):  $V_{LCD} = \sqrt{6} \times V_{off(RMS)} = 2.449V_{off(RMS)}$
- 1:4 multiplex ( $\frac{1}{2}$  bias):  $V_{LCD} = \left[ \frac{4 \times \sqrt{3}}{3} \right] = 2.309V_{off(RMS)}$

These compare with  $V_{LCD} = 3V_{off(RMS)}$  when  $\frac{1}{3}$  bias is used.

It should be noted that  $V_{LCD}$  is sometimes referred as the LCD operating voltage.

7.4 LCD drive mode waveforms

7.4.1 Static drive mode

The static LCD drive mode is used when a single backplane is provided in the LCD. The backplane (BP<sub>n</sub>) and segment drive (S<sub>n</sub>) waveforms for this mode are shown in [Figure 6](#).

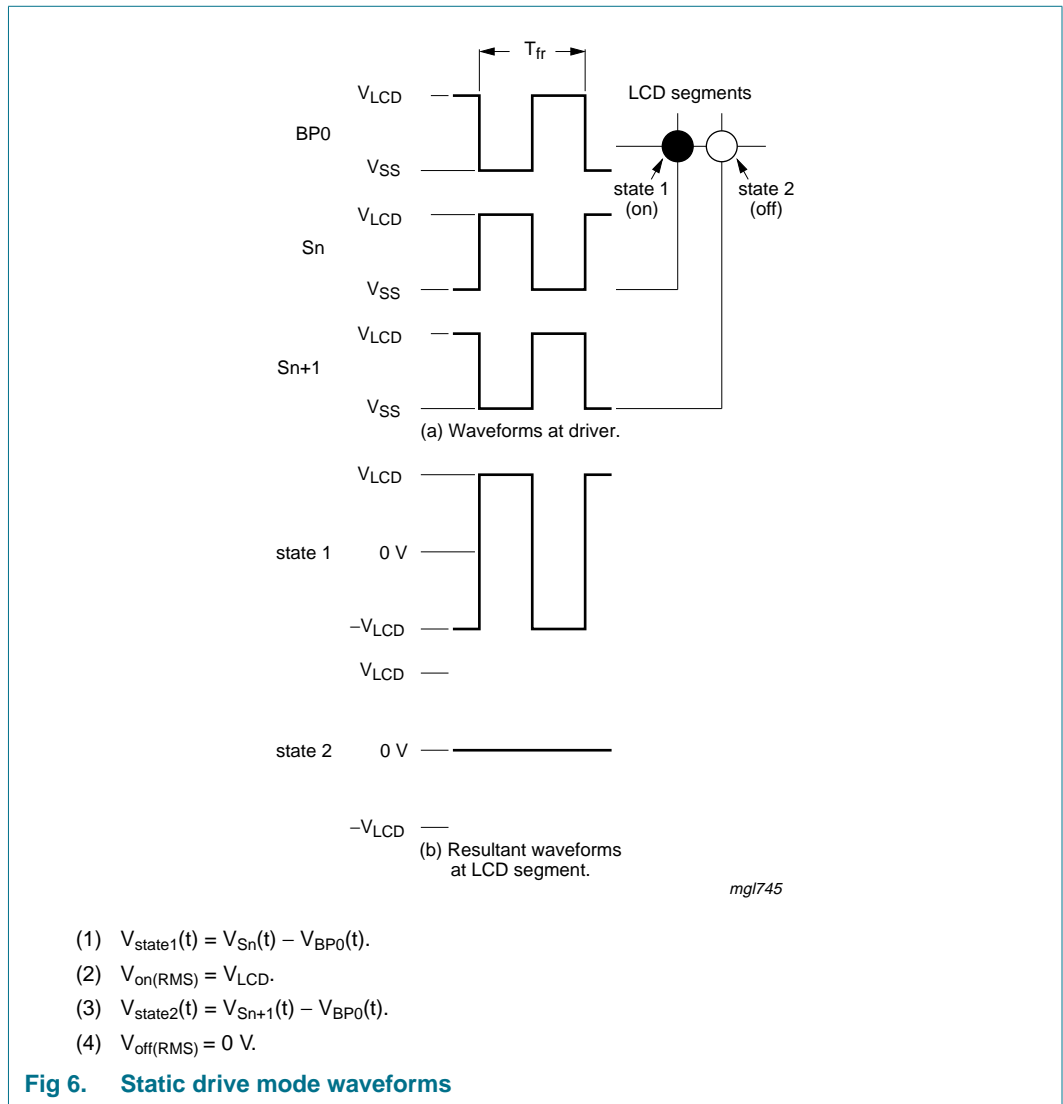

7.4.2 1:2 Multiplex drive mode

The 1:2 multiplex drive mode is used when two backplanes are provided in the LCD. This mode allows fractional LCD bias voltages of  $\frac{1}{2}$  bias or  $\frac{1}{3}$  bias as shown in [Figure 7](#) and [Figure 8](#).

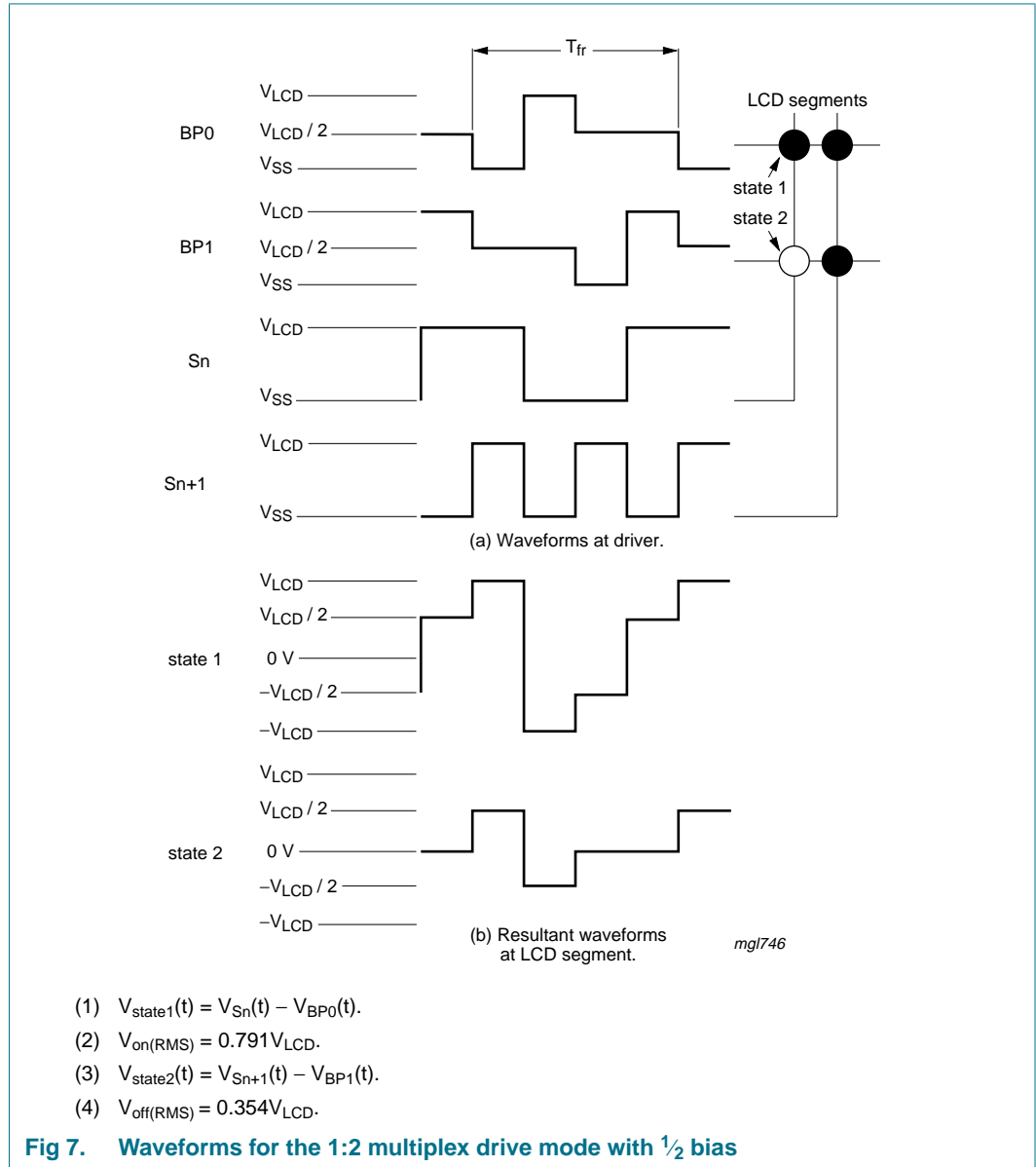

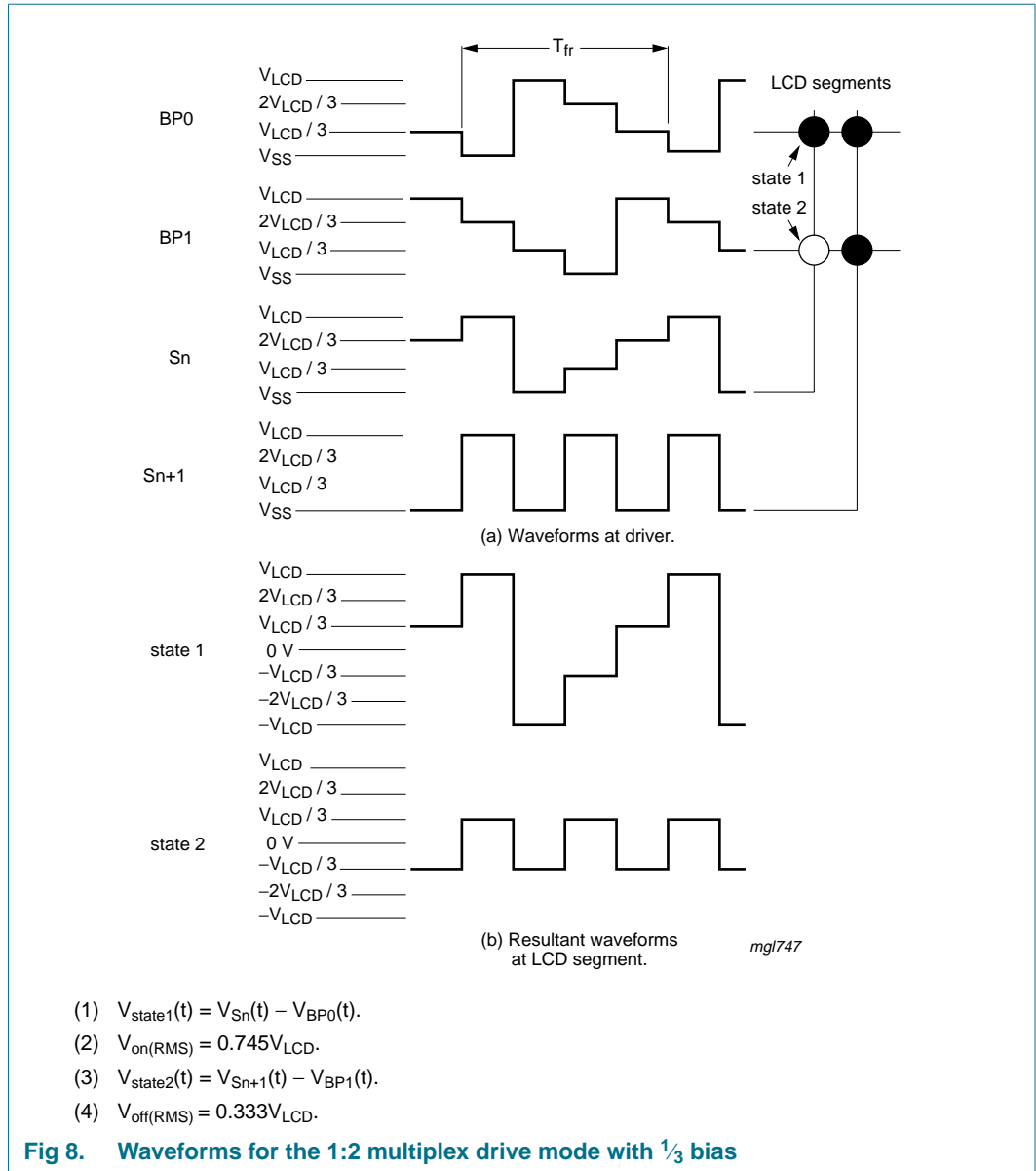

7.4.3 1:3 Multiplex drive mode

When three backplanes are provided in the LCD, the 1:3 multiplex drive mode applies (see Figure 9).

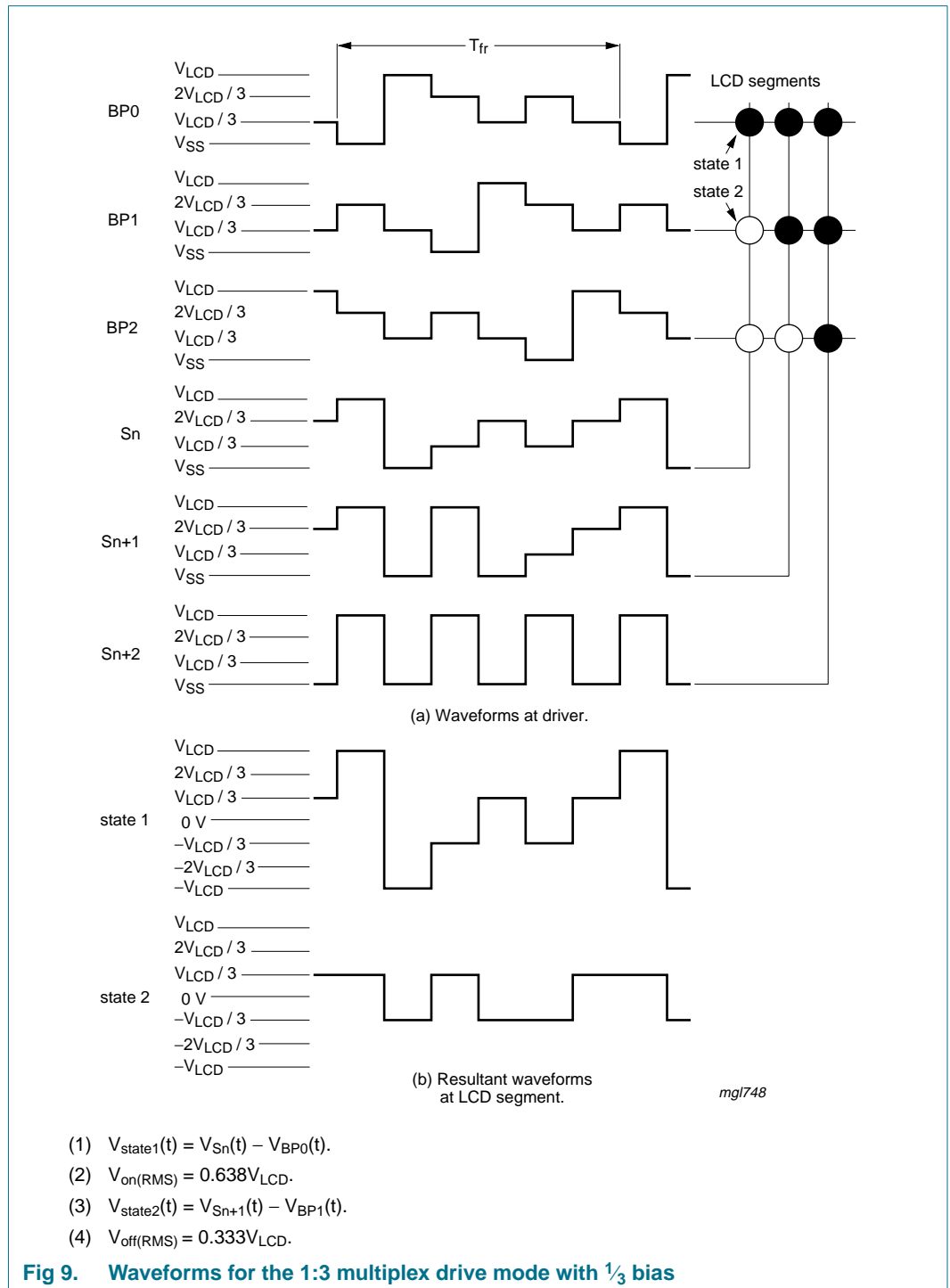

Fig 9. Waveforms for the 1:3 multiplex drive mode with 1/3 bias

7.4.4 1:4 Multiplex drive mode

When four backplanes are provided in the LCD, the 1:4 multiplex drive mode applies (see Figure 10).

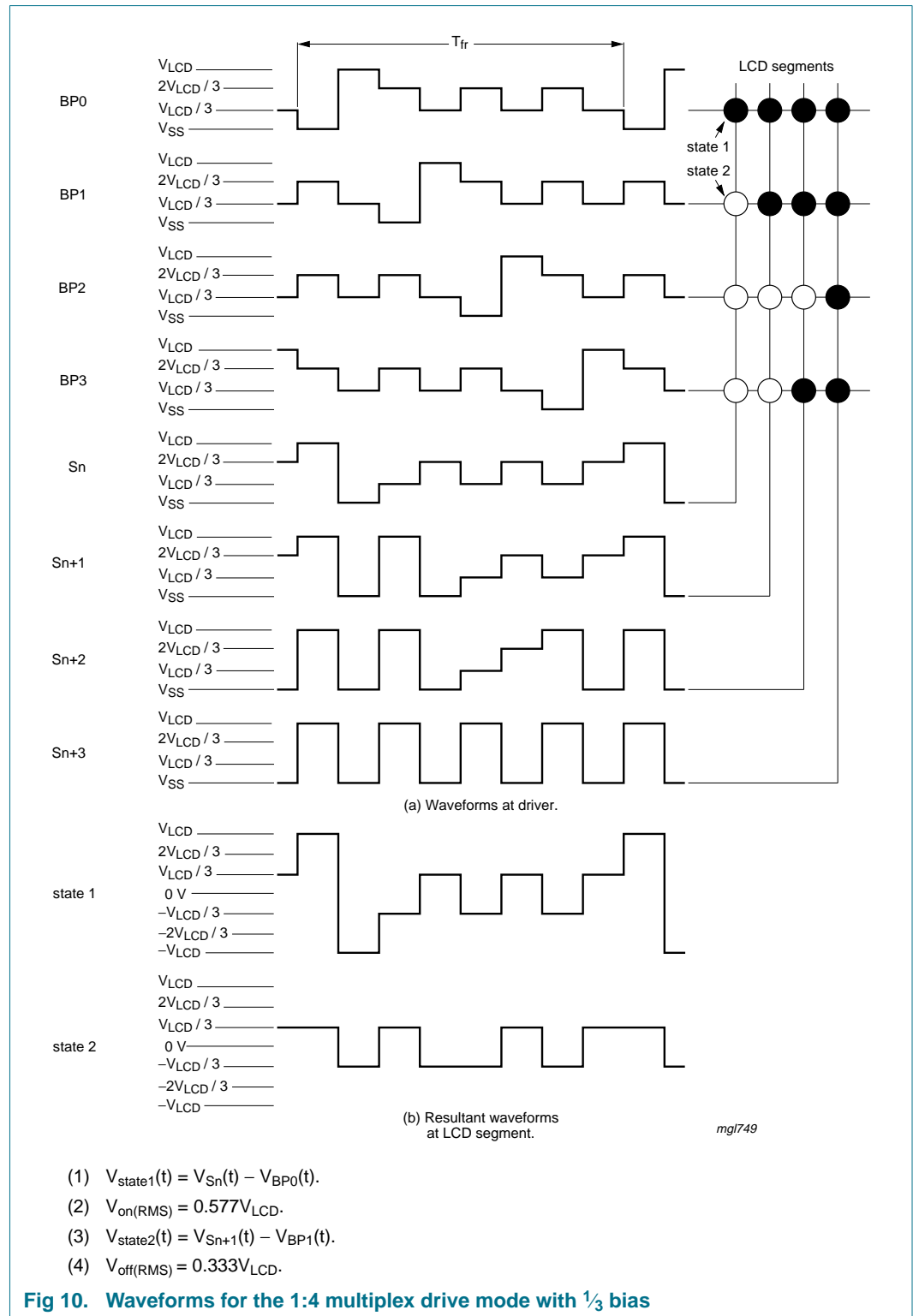

Fig 10. Waveforms for the 1:4 multiplex drive mode with 1/3 bias

## 7.5 Oscillator

### 7.5.1 Internal clock

The internal logic of the PCF8576D and its LCD drive signals are timed either by its internal oscillator or by an external clock. The internal oscillator is enabled by connecting pin OSC to pin V<sub>SS</sub>. If the internal oscillator is used, the output from pin CLK can be used as the clock signal for several PCF8576Ds in the system that are connected in cascade. After power-on, pin SDA must be HIGH to guarantee that the clock starts.

### 7.5.2 External clock

Pin CLK is enabled as an external clock input by connecting pin OSC to V<sub>DD</sub>.

The LCD frame signal frequency is determined by the clock frequency ( $f_{clk}$ ).

A clock signal must always be supplied to the device; removing the clock freezes the LCD in a DC state.

## 7.6 Timing

The PCF8576D timing controls the internal data flow of the device. This includes the transfer of display data from the display RAM to the display segment outputs. In cascaded applications, the correct timing relationship between each PCF8576D in the system is maintained by the synchronization signal at pin SYNC. The timing also generates the LCD frame signal whose frequency is derived from the clock frequency. The frame signal frequency is a fixed division of the clock frequency from either the internal or an external

$$\text{clock: } f_{fr} = \frac{f_{clk}}{24}$$

## 7.7 Display register

The display latch holds the display data while the corresponding multiplex signals are generated. There is a one-to-one relationship between the data in the display latch, the LCD segment outputs and each column of the display RAM.

## 7.8 Segment outputs

The LCD drive section includes 40 segment outputs S0 to S39 which should be connected directly to the LCD. The segment output signals are generated in accordance with the multiplexed backplane signals and with data residing in the display latch. When less than 40 segment outputs are required, the unused segment outputs should be left open-circuit.

## 7.9 Backplane outputs

The LCD drive section includes four backplane outputs BP0 to BP3 which must be connected directly to the LCD. The backplane output signals are generated in accordance with the selected LCD drive mode. If less than four backplane outputs are required, the unused outputs can be left open-circuit.

In the 1:3 multiplex drive mode, BP3 carries the same signal as BP1, therefore these two adjacent outputs can be tied together to give enhanced drive capabilities.





In the 1:4 mode, the eight transmitted data bits are placed in bits 0, 1, 2 and 3 of two successive display RAM addresses.

### 7.11 Data pointer

The addressing mechanism for the display RAM is realized using the data pointer. This allows the loading of an individual display data byte, or a series of display data bytes, into any location of the display RAM. The sequence commences with the initialization of the data pointer by the load-data-pointer command (see [Section 7.17](#)). Following this, an arriving data byte is stored at the display RAM address indicated by the data pointer in accordance with the filling order shown in [Figure 12](#). After each byte is stored, the contents of the data pointer are automatically incremented by a value dependent on the selected LCD drive mode: eight (static drive mode), four (1:2 mode), three (1:3 mode) or two (1:4 mode). If an I<sup>2</sup>C-bus data access is terminated early then the state of the data pointer will be unknown. The data pointer should be re-written prior to further RAM access.

| drive mode    | LCD segments | LCD backplanes | display RAM filling order  | transmitted display byte |     |     |         |         |         |     |     |     |         |   |    |   |   |   |   |    |    |    |   |   |   |   |   |   |   |   |   |   |   |   |   |   |   |   |   |   |   |   |  |   |   |   |   |   |   |   |   |   |   |
|---------------|--------------|----------------|--|--------------------------|-----|-----|---------|---------|---------|-----|-----|-----|---------|---|----|---|---|---|---|----|----|----|---|---|---|---|---|---|---|---|---|---|---|---|---|---|---|---|---|---|---|---|--|---|---|---|---|---|---|---|---|---|---|
| static        |              |                | <table border="1"> <thead> <tr> <th></th> <th>n</th> <th>n+1</th> <th>n+2</th> <th>n+3</th> <th>n+4</th> <th>n+5</th> <th>n+6</th> <th>n+7</th> </tr> </thead> <tbody> <tr> <td>bit/ BP</td> <td>0</td> <td>c</td> <td>b</td> <td>a</td> <td>f</td> <td>g</td> <td>e</td> <td>d</td> <td>DP</td> </tr> <tr> <td></td> <td>1</td> <td>x</td> <td>x</td> <td>x</td> <td>x</td> <td>x</td> <td>x</td> <td>x</td> <td>x</td> </tr> <tr> <td></td> <td>2</td> <td>x</td> <td>x</td> <td>x</td> <td>x</td> <td>x</td> <td>x</td> <td>x</td> <td>x</td> </tr> <tr> <td></td> <td>3</td> <td>x</td> <td>x</td> <td>x</td> <td>x</td> <td>x</td> <td>x</td> <td>x</td> <td>x</td> </tr> </tbody> </table> |                          | n   | n+1 | n+2     | n+3     | n+4     | n+5 | n+6 | n+7 | bit/ BP | 0 | c  | b | a | f | g | e  | d  | DP |   | 1 | x | x | x | x   | x | x | x | x |   | 2 | x | x | x | x | x | x | x | x |  | 3 | x | x | x | x | x | x | x | x | <p>MSB</p> <p>LSB</p> <p>c b a f g e d DP</p> |
|               | n            | n+1            | n+2  | n+3                      | n+4 | n+5 | n+6     | n+7     |         |     |     |     |         |   |    |   |   |   |   |    |    |    |   |   |   |   |   |   |   |   |   |   |   |   |   |   |   |   |   |   |   |   |  |   |   |   |   |   |   |   |   |   |   |
| bit/ BP       | 0            | c              | b  | a                        | f   | g   | e       | d       | DP      |     |     |     |         |   |    |   |   |   |   |    |    |    |   |   |   |   |   |   |   |   |   |   |   |   |   |   |   |   |   |   |   |   |  |   |   |   |   |   |   |   |   |   |   |
|               | 1            | x              | x  | x                        | x   | x   | x       | x       | x       |     |     |     |         |   |    |   |   |   |   |    |    |    |   |   |   |   |   |   |   |   |   |   |   |   |   |   |   |   |   |   |   |   |  |   |   |   |   |   |   |   |   |   |   |
|               | 2            | x              | x  | x                        | x   | x   | x       | x       | x       |     |     |     |         |   |    |   |   |   |   |    |    |    |   |   |   |   |   |   |   |   |   |   |   |   |   |   |   |   |   |   |   |   |  |   |   |   |   |   |   |   |   |   |   |
|               | 3            | x              | x  | x                        | x   | x   | x       | x       | x       |     |     |     |         |   |    |   |   |   |   |    |    |    |   |   |   |   |   |   |   |   |   |   |   |   |   |   |   |   |   |   |   |   |  |   |   |   |   |   |   |   |   |   |   |
| 1:2 multiplex |              |                | <table border="1"> <thead> <tr> <th></th> <th>n</th> <th>n+1</th> <th>n+2</th> <th>n+3</th> </tr> </thead> <tbody> <tr> <td>bit/ BP</td> <td>0</td> <td>a</td> <td>f</td> <td>e</td> <td>d</td> </tr> <tr> <td></td> <td>1</td> <td>b</td> <td>g</td> <td>c</td> <td>DP</td> </tr> <tr> <td></td> <td>2</td> <td>x</td> <td>x</td> <td>x</td> <td>x</td> </tr> <tr> <td></td> <td>3</td> <td>x</td> <td>x</td> <td>x</td> <td>x</td> </tr> </tbody> </table>   |                          | n   | n+1 | n+2     | n+3     | bit/ BP | 0   | a   | f   | e       | d |    | 1 | b | g | c | DP |    | 2  | x   | x | x | x |   | 3   | x | x | x | x | <p>MSB</p> <p>LSB</p> <p>a b f g e c d DP</p> |   |   |   |   |   |   |   |   |   |  |   |   |   |   |   |   |   |   |   |   |
|               | n            | n+1            | n+2  | n+3                      |     |     |         |         |         |     |     |     |         |   |    |   |   |   |   |    |    |    |   |   |   |   |   |   |   |   |   |   |   |   |   |   |   |   |   |   |   |   |  |   |   |   |   |   |   |   |   |   |   |
| bit/ BP       | 0            | a              | f  | e                        | d   |     |         |         |         |     |     |     |         |   |    |   |   |   |   |    |    |    |   |   |   |   |   |   |   |   |   |   |   |   |   |   |   |   |   |   |   |   |  |   |   |   |   |   |   |   |   |   |   |
|               | 1            | b              | g  | c                        | DP  |     |         |         |         |     |     |     |         |   |    |   |   |   |   |    |    |    |   |   |   |   |   |   |   |   |   |   |   |   |   |   |   |   |   |   |   |   |  |   |   |   |   |   |   |   |   |   |   |
|               | 2            | x              | x  | x                        | x   |     |         |         |         |     |     |     |         |   |    |   |   |   |   |    |    |    |   |   |   |   |   |   |   |   |   |   |   |   |   |   |   |   |   |   |   |   |  |   |   |   |   |   |   |   |   |   |   |
|               | 3            | x              | x  | x                        | x   |     |         |         |         |     |     |     |         |   |    |   |   |   |   |    |    |    |   |   |   |   |   |   |   |   |   |   |   |   |   |   |   |   |   |   |   |   |  |   |   |   |   |   |   |   |   |   |   |
| 1:3 multiplex |              |                | <table border="1"> <thead> <tr> <th></th> <th>n</th> <th>n+1</th> <th>n+2</th> </tr> </thead> <tbody> <tr> <td>bit/ BP</td> <td>0</td> <td>b</td> <td>a</td> <td>f</td> </tr> <tr> <td></td> <td>1</td> <td>DP</td> <td>d</td> <td>e</td> </tr> <tr> <td></td> <td>2</td> <td>c</td> <td>g</td> <td>x</td> </tr> <tr> <td></td> <td>3</td> <td>x</td> <td>x</td> <td>x</td> </tr> </tbody> </table>  |                          | n   | n+1 | n+2     | bit/ BP | 0       | b   | a   | f   |         | 1 | DP | d | e |   | 2 | c  | g  | x  |   | 3 | x | x | x | <p>MSB</p> <p>LSB</p> <p>b DP c a d g f e</p> |   |   |   |   |   |   |   |   |   |   |   |   |   |   |  |   |   |   |   |   |   |   |   |   |   |
|               | n            | n+1            | n+2  |                          |     |     |         |         |         |     |     |     |         |   |    |   |   |   |   |    |    |    |   |   |   |   |   |   |   |   |   |   |   |   |   |   |   |   |   |   |   |   |  |   |   |   |   |   |   |   |   |   |   |
| bit/ BP       | 0            | b              | a  | f                        |     |     |         |         |         |     |     |     |         |   |    |   |   |   |   |    |    |    |   |   |   |   |   |   |   |   |   |   |   |   |   |   |   |   |   |   |   |   |  |   |   |   |   |   |   |   |   |   |   |
|               | 1            | DP             | d  | e                        |     |     |         |         |         |     |     |     |         |   |    |   |   |   |   |    |    |    |   |   |   |   |   |   |   |   |   |   |   |   |   |   |   |   |   |   |   |   |  |   |   |   |   |   |   |   |   |   |   |
|               | 2            | c              | g  | x                        |     |     |         |         |         |     |     |     |         |   |    |   |   |   |   |    |    |    |   |   |   |   |   |   |   |   |   |   |   |   |   |   |   |   |   |   |   |   |  |   |   |   |   |   |   |   |   |   |   |
|               | 3            | x              | x  | x                        |     |     |         |         |         |     |     |     |         |   |    |   |   |   |   |    |    |    |   |   |   |   |   |   |   |   |   |   |   |   |   |   |   |   |   |   |   |   |  |   |   |   |   |   |   |   |   |   |   |
| 1:4 multiplex |              |                | <table border="1"> <thead> <tr> <th></th> <th>n</th> <th>n+1</th> </tr> </thead> <tbody> <tr> <td>bit/ BP</td> <td>0</td> <td>a</td> <td>f</td> </tr> <tr> <td></td> <td>1</td> <td>c</td> <td>e</td> </tr> <tr> <td></td> <td>2</td> <td>b</td> <td>g</td> </tr> <tr> <td></td> <td>3</td> <td>DP</td> <td>d</td> </tr> </tbody> </table>   |                          | n   | n+1 | bit/ BP | 0       | a       | f   |     | 1   | c       | e |    | 2 | b | g |   | 3  | DP | d  | <p>MSB</p> <p>LSB</p> <p>a c b DP f e g d</p> |   |   |   |   |   |   |   |   |   |   |   |   |   |   |   |   |   |   |   |  |   |   |   |   |   |   |   |   |   |   |
|               | n            | n+1            |  |                          |     |     |         |         |         |     |     |     |         |   |    |   |   |   |   |    |    |    |   |   |   |   |   |   |   |   |   |   |   |   |   |   |   |   |   |   |   |   |  |   |   |   |   |   |   |   |   |   |   |
| bit/ BP       | 0            | a              | f  |                          |     |     |         |         |         |     |     |     |         |   |    |   |   |   |   |    |    |    |   |   |   |   |   |   |   |   |   |   |   |   |   |   |   |   |   |   |   |   |  |   |   |   |   |   |   |   |   |   |   |
|               | 1            | c              | e  |                          |     |     |         |         |         |     |     |     |         |   |    |   |   |   |   |    |    |    |   |   |   |   |   |   |   |   |   |   |   |   |   |   |   |   |   |   |   |   |  |   |   |   |   |   |   |   |   |   |   |
|               | 2            | b              | g  |                          |     |     |         |         |         |     |     |     |         |   |    |   |   |   |   |    |    |    |   |   |   |   |   |   |   |   |   |   |   |   |   |   |   |   |   |   |   |   |  |   |   |   |   |   |   |   |   |   |   |
|               | 3            | DP             | d  |                          |     |     |         |         |         |     |     |     |         |   |    |   |   |   |   |    |    |    |   |   |   |   |   |   |   |   |   |   |   |   |   |   |   |   |   |   |   |   |  |   |   |   |   |   |   |   |   |   |   |

001aag281

x = data bit unchanged.

Fig 12. Relationship between LCD layout, drive mode, display RAM filling order and display data transmitted over the I<sup>2</sup>C-bus

## 7.12 Output bank selector

The output bank selector selects one of the four bits per display RAM address for transfer to the display latch. The actual bit chosen depends on the selected LCD drive mode in operation and on the instant in the multiplex sequence.

- In 1:4 mode, all RAM addresses of bit 0 are selected, these are followed by the contents of bit 1, bit 2 and then bit 3.
- In 1:3 mode, bits 0, 1 and 2 are selected sequentially
- In 1:2 mode, bits 0 and 1 are selected
- In static mode, bit 0 is selected

The  $\overline{\text{SYNC}}$  signal resets these sequences to the following starting points:

- Bit 3 for 1:4 mode
- Bit 2 for 1:3 mode
- Bit 1 for 1:2 mode
- Bit 0 for static mode

The PCF8576D includes a RAM bank switching feature in the static and 1:2 drive modes. In the static drive mode, the bank-select command (see [Section 7.17](#)) may request the contents of bit 2 to be selected for display instead of the contents of bit 0. In 1:2 mode, the contents of bits 2 and 3 may be selected instead of bits 0 and 1. This gives the provision for preparing display information in an alternative bank and to be able to switch to it once it is assembled.

## 7.13 Input bank selector

The input bank selector loads display data into the display RAM in accordance with the selected LCD drive configuration.

The bank-select command (see [Section 7.17](#)) can be used to load display data in bit 2 in static drive mode or in bits 2 and 3 in 1:2 mode. The input bank selector functions are independent of the output bank selector.

## 7.14 Subaddress counter

The storage of display data is determined by the contents of the subaddress counter. Storage is allowed to take place only when the contents of the subaddress counter agree with the hardware subaddress applied to A0, A1 and A2. The subaddress counter value is defined by the device-select command (see [Section 7.17](#)). If the contents of the subaddress counter and the hardware subaddress do not agree then data storage is inhibited but the data pointer is incremented as if data storage had taken place. The subaddress counter is also incremented when the data pointer overflows.

The storage arrangements described lead to extremely efficient data loading in cascaded applications. When a series of display bytes are sent to the display RAM, automatic wrap-over to the next PCF8576D occurs when the last RAM address is exceeded. Subaddressing across device boundaries is successful even if the change to the next device in the cascade occurs within a transmitted character (such as during the 14<sup>th</sup> display data byte transmitted in 1:3 mode).

The hardware subaddress must not be changed while the device is being accessed on the I<sup>2</sup>C-bus interface.

### 7.15 Blinker

The PCF8576D has a very versatile display blinking capability. The whole display can blink at a frequency selected by the blink-select command (see [Section 7.17](#)). Each blink frequency is a fraction of the clock frequency; the ratio between the clock frequency and blink frequency depends on the blink mode selected (see [Table 6](#)).

An additional feature allows an arbitrary selection of LCD segments to blink in the static and 1:2 drive modes. This is implemented without any communication overheads by the output bank selector which alternates the displayed data between the data in the display RAM bank and the data in an alternative RAM bank at the blink frequency. This mode can also be implemented by the blink-select command (see [Section 7.17](#)).

In the 1:3 and 1:4 drive modes, where no alternative RAM bank is available, groups of LCD segments can blink selectively by changing the display RAM data at fixed time intervals.

The entire display can blink at a frequency other than the nominal blink frequency by sequentially resetting and setting the display enable bit E at the required rate using the mode-set command (see [Section 7.17](#)).

**Table 6. Blinking frequencies<sup>[1]</sup>**

| Blink mode | Normal operating mode ratio | Nominal blink frequency |
|------------|-----------------------------|-------------------------|
| off        | -                           | blinking off            |
| 1          | $\frac{f_{clk}}{768}$       | 2 Hz                    |
| 2          | $\frac{f_{clk}}{1536}$      | 1 Hz                    |
| 3          | $\frac{f_{clk}}{3072}$      | 0.5 Hz                  |

[1] Blink modes 1, 2 and 3 and the nominal blink frequencies 0.5 Hz, 1 Hz and 2 Hz correspond to an oscillator frequency (f<sub>clk</sub>) of 1536 Hz (see [Section 11](#)).

### 7.16 Characteristics of the I<sup>2</sup>C-bus

The I<sup>2</sup>C-bus is for bidirectional, two-line communication between different ICs or modules. The two lines are a serial data line (SDA) and a serial clock line (SCL). Both lines must be connected to a positive supply via a pull-up resistor when connected to the output stages of a device. Data transfer may be initiated only when the bus is not busy.

#### 7.16.1 Bit transfer

One data bit is transferred during each clock pulse. The data on the SDA line must remain stable during the HIGH period of the clock pulse as changes in the data line at this time will be interpreted as a control signal (see [Figure 13](#)).

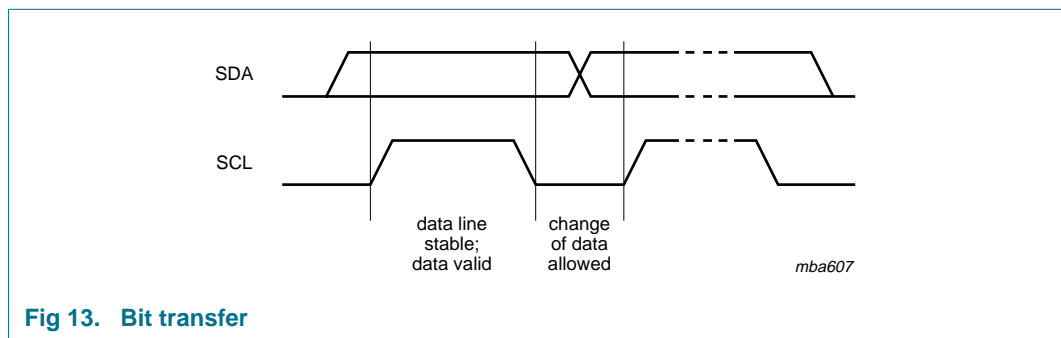

Fig 13. Bit transfer

#### 7.16.2 START and STOP conditions

Both data and clock lines remain HIGH when the bus is not busy.

A HIGH-to-LOW transition of the data line while the clock is HIGH is defined as the START condition - S.

A LOW-to-HIGH transition of the data line while the clock is HIGH is defined as the STOP condition - P (see [Figure 14](#)).

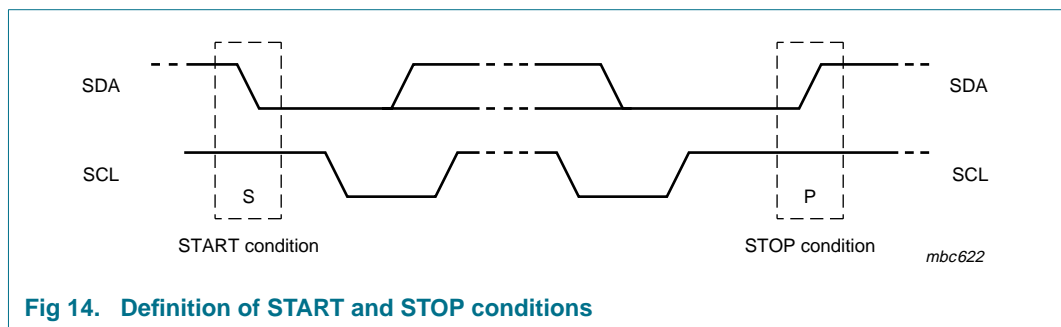

Fig 14. Definition of START and STOP conditions

#### 7.16.3 System configuration

A device generating a message is a transmitter, a device receiving a message is the receiver. The device that controls the message is the master and the devices which are controlled by the master are the slaves (see [Figure 15](#)).

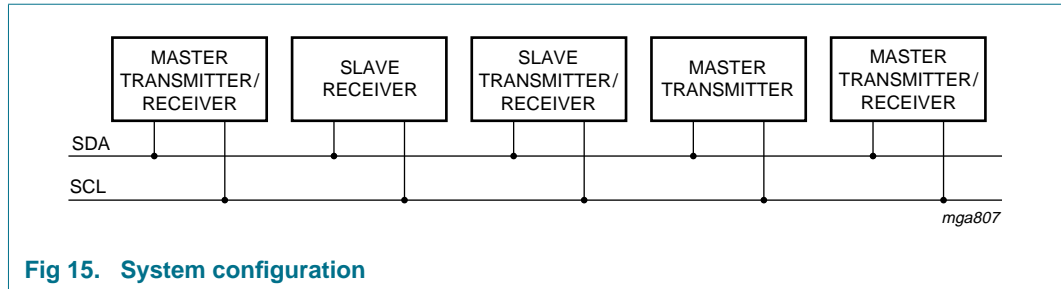

Fig 15. System configuration

7.16.4 Acknowledge

The number of data bytes that can be transferred from transmitter to receiver between the START and STOP conditions is unlimited. Each byte of eight bits is followed by an acknowledge bit. The acknowledge bit is a HIGH-level signal on the bus that is asserted by the transmitter during which time the master generates an extra acknowledge related clock pulse. An addressed slave receiver must generate an acknowledge after receiving each byte. Also a master receiver must generate an acknowledge after receiving each byte that has been clocked out of the slave transmitter. The acknowledging device must pull-down the SDA line during the acknowledge clock pulse so that the SDA line is stable LOW during the HIGH period of the acknowledge related clock pulse (set-up and hold times must be taken into consideration). A master receiver must signal an end of data to the transmitter by not generating an acknowledge on the last byte that has been clocked out of the slave. In this event the transmitter must leave the data line HIGH to enable the master to generate a STOP condition (see Figure 16).

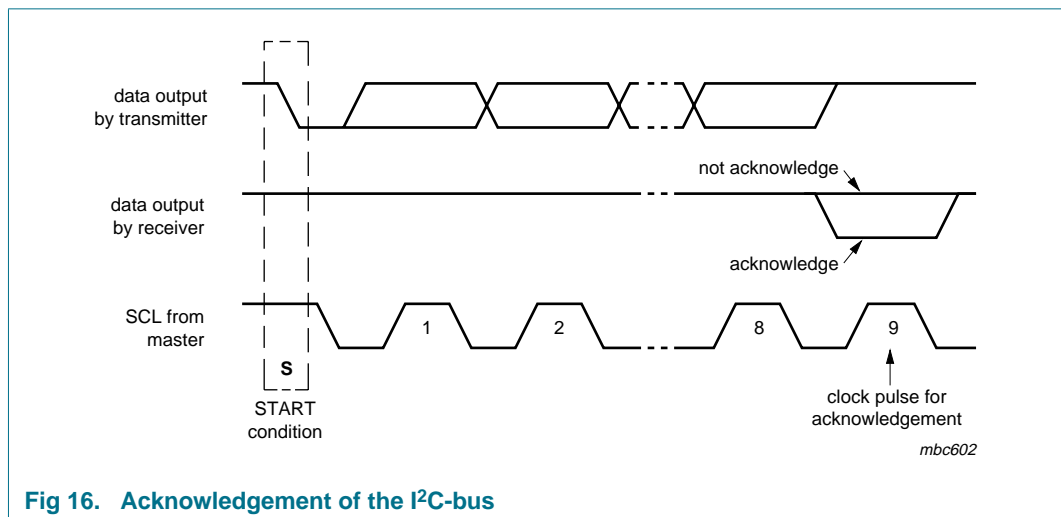

Fig 16. Acknowledgement of the I<sup>2</sup>C-bus

7.16.5 I<sup>2</sup>C-bus controller

The PCF8576D acts as an I<sup>2</sup>C-bus slave receiver. It does not initiate I<sup>2</sup>C-bus transfers or transmit data to an I<sup>2</sup>C-bus master receiver. The only data output from the PCF8576D are the acknowledge signals of the selected devices. Device selection depends on the I<sup>2</sup>C-bus slave address, on the transferred command data and on the hardware subaddress.

In single device applications, the hardware subaddress inputs A0, A1 and A2 are normally tied to V<sub>SS</sub> which defines the hardware subaddress 0. In multiple device applications A0, A1 and A2 are tied to V<sub>SS</sub> or V<sub>DD</sub> in accordance with a binary coding scheme such that no two devices with a common I<sup>2</sup>C-bus slave address have the same hardware subaddress.

**7.16.6 Input filters**

To enhance noise immunity in electrically adverse environments, RC low-pass filters are provided on the SDA and SCL lines.

**7.16.7 I<sup>2</sup>C-bus protocol**

Two I<sup>2</sup>C-bus slave addresses (0111 000 and 0111 001) are reserved for the PCF8576D. The least significant bit of the slave address that a PCF8576D will respond to is defined by the level tied to its SA0 input. The PCF8576D is a write-only device and will not respond to a read access. Having two reserved slave addresses allows the following on the same I<sup>2</sup>C-bus:

- Up to 16 PCF8576Ds for very large LCD applications
- The use of two types of LCD multiplex drive.

The I<sup>2</sup>C-bus protocol is shown in Figure 17. The sequence is initiated with a START condition (S) from the I<sup>2</sup>C-bus master which is followed by one of two possible PCF8576D slave addresses available. All PCF8576Ds whose SA0 inputs correspond to bit 0 of the slave address respond by asserting an acknowledge in parallel. This I<sup>2</sup>C-bus transfer is ignored by all PCF8576Ds whose SA0 inputs are set to the alternative level.

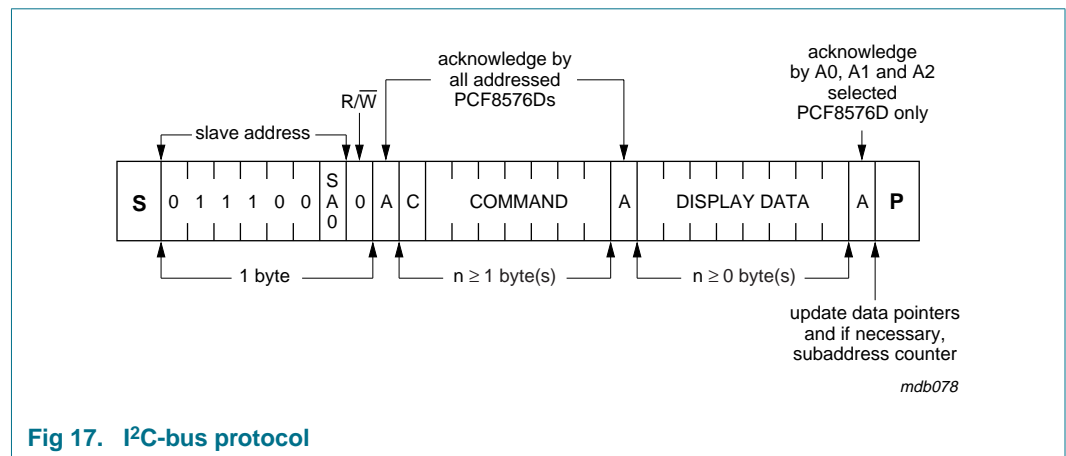

Fig 17. I<sup>2</sup>C-bus protocol

After an acknowledgement, one or more command bytes follow, that define the status of each addressed PCF8576D.

The last command byte sent is identified by resetting its most significant bit, continuation bit C, (see Figure 18). The command bytes are also acknowledged by all addressed PCF8576Ds on the bus.



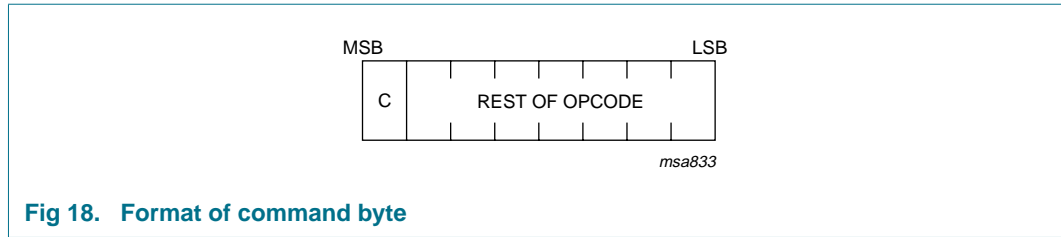

Fig 18. Format of command byte

After the last command byte, one or more display data bytes may follow. Display data bytes are stored in the display RAM at the address specified by the data pointer and the subaddress counter. Both data pointer and subaddress counter are automatically updated and the data directed to the intended PCF8576D device.

An acknowledgement after each byte is asserted only by the PCF8576Ds that are addressed via address lines A0, A1 and A2. After the last display byte, the I<sup>2</sup>C-bus master asserts a STOP condition (P). Alternately a START may be asserted to restart an I<sup>2</sup>C-bus access.

### 7.17 Command decoder

The command decoder identifies command bytes that arrive on the I<sup>2</sup>C-bus.

The commands available to the PCF8576D are defined in [Table 7](#).

Table 7. Definition of PCF8576D commands

| Command           | Operation Code |   |    |     |    |    |     |     | Reference                |
|-------------------|----------------|---|----|-----|----|----|-----|-----|--------------------------|
|                   | 7              | 6 | 5  | 4   | 3  | 2  | 1   | 0   |                          |
| mode-set          | C              | 1 | 0  | [1] | E  | B  | M1  | M0  | <a href="#">Table 9</a>  |
| load-data-pointer | C              | 0 | P5 | P4  | P3 | P2 | P1  | P0  | <a href="#">Table 10</a> |
| device-select     | C              | 1 | 1  | 0   | 0  | A2 | A1  | A0  | <a href="#">Table 11</a> |
| bank-select       | C              | 1 | 1  | 1   | 1  | 0  | I   | O   | <a href="#">Table 12</a> |
| blink-select      | C              | 1 | 1  | 1   | 0  | A  | BF1 | BF0 | <a href="#">Table 13</a> |

[1] Not used.

All available commands carry a continuation bit C in their most significant bit position as shown in [Figure 18](#). When this bit is set, it indicates that the next byte of the transfer to arrive will also represent a command. If this bit is reset, it indicates that the command byte is the last in the transfer. Further bytes will be regarded as display data (see [Table 8](#)).

Table 8. C bit description

| Bit | Symbol | Value | Description   |
|-----|--------|-------|---|
| 7   | C      |       | <b>continue bit</b>   |
|     |        | 0     | last control byte in the transfer; next byte will be regarded as display data |
|     |        | 1     | control bytes continue; next byte will be a command too                       |

**Table 9. Mode-set command bits description**

| Bit    | Symbol | Value | Description                       |
|--------|--------|-------|-----------------------------------|
| 7      | C      | 0, 1  | see <a href="#">Table 8</a>       |
| 6, 5   | -      | 10    | fixed value                       |
| 4      | -      | -     | unused                            |
| 3      | E      |       | <b>display status</b>             |
|        |        | 0     | disabled (blank) <sup>[1]</sup>   |
|        |        | 1     | enabled                           |
| 2      | B      |       | <b>LCD bias configuration</b>     |
|        |        | 0     | $\frac{1}{3}$ bias                |
|        |        | 1     | $\frac{1}{2}$ bias                |
| 1 to 0 | M[1:0] |       | <b>LCD drive mode selection</b>   |
|        |        | 01    | static; BP0                       |
|        |        | 10    | 1:2 multiplex; BP0, BP1           |
|        |        | 11    | 1:3 multiplex; BP0, BP1, BP2      |
|        |        | 00    | 1:4 multiplex; BP0, BP1, BP2, BP3 |

[1] The possibility to disable the display allows implementation of blinking under external control.

**Table 10. Load-data-pointer command bits description**

| Bit    | Symbol | Value            | Description   |
|--------|--------|------------------|---|
| 7      | C      | 0, 1             | see <a href="#">Table 8</a>   |
| 6      | -      | 0                | fixed value   |
| 5 to 0 | P[5:0] | 000000 to 100111 | 6 bit binary value, 0 to 39; transferred to the data pointer to define one of forty display RAM addresses |

**Table 11. Device-select command bits description**

| Bit    | Symbol | Value      | Description  |
|--------|--------|------------|--|
| 7      | C      | 0, 1       | see <a href="#">Table 8</a>  |
| 6 to 3 | -      | 1100       | fixed value  |
| 2 to 0 | A[2:0] | 000 to 111 | 3 bit binary value, 0 to 7; transferred to the subaddress counter to define one of eight hardware subaddresses |

**Table 12. Bank-select command bits description**

| Bit    | Symbol | Value | Description  |                              |
|--------|--------|-------|--|------------------------------|
|        |        |       | Static   | 1:2 multiplex <sup>[1]</sup> |
| 7      | C      | 0, 1  | see <a href="#">Table 8</a>                                    |                              |
| 6 to 2 | -      | 11110 | fixed value  |                              |
| 1      | I      |       | <b>input bank selection</b> ; storage of arriving display data |                              |
|        |        | 0     | RAM bit 0  | RAM bits 0 and 1             |
|        |        | 1     | RAM bit 2  | RAM bits 2 and 3             |
| 0      | O      |       | <b>output bank selection</b> ; retrieval of LCD display data   |                              |
|        |        | 0     | RAM bit 0  | RAM bits 0 and 1             |
|        |        | 1     | RAM bit 2  | RAM bits 2 and 3             |

[1] The bank-select command has no effect in 1:3 and 1:4 multiplex drive modes.

**Table 13. Blink-select command bits description**

| Bit    | Symbol  | Value | Description                                |
|--------|---------|-------|--|
| 7      | C       | 0, 1  | see <a href="#">Table 8</a>                |
| 6 to 3 | -       | 1110  | fixed value                                |
| 2      | A       |       | <b>blink mode selection</b>                |
|        |         | 0     | normal blinking <sup>[1]</sup>             |
|        |         | 1     | alternate RAM bank blinking <sup>[2]</sup> |
| 1 to 0 | BF[1:0] |       | <b>blink frequency selection</b>           |
|        |         | 00    | off  |
|        |         | 01    | 1  |
|        |         | 10    | 2  |
|        |         | 11    | 3  |

[1] Normal blinking is assumed when the LCD multiplex drive modes 1:3 or 1:4 are selected.

[2] Alternating RAM bank blinking does not apply in 1:3 and 1:4 multiplex drive modes.

## 7.18 Display controller

The display controller executes the commands identified by the command decoder. It contains the device's status registers and coordinates their effects. The display controller is also responsible for loading display data into the display RAM in the correct filling order.

8. Internal circuitry

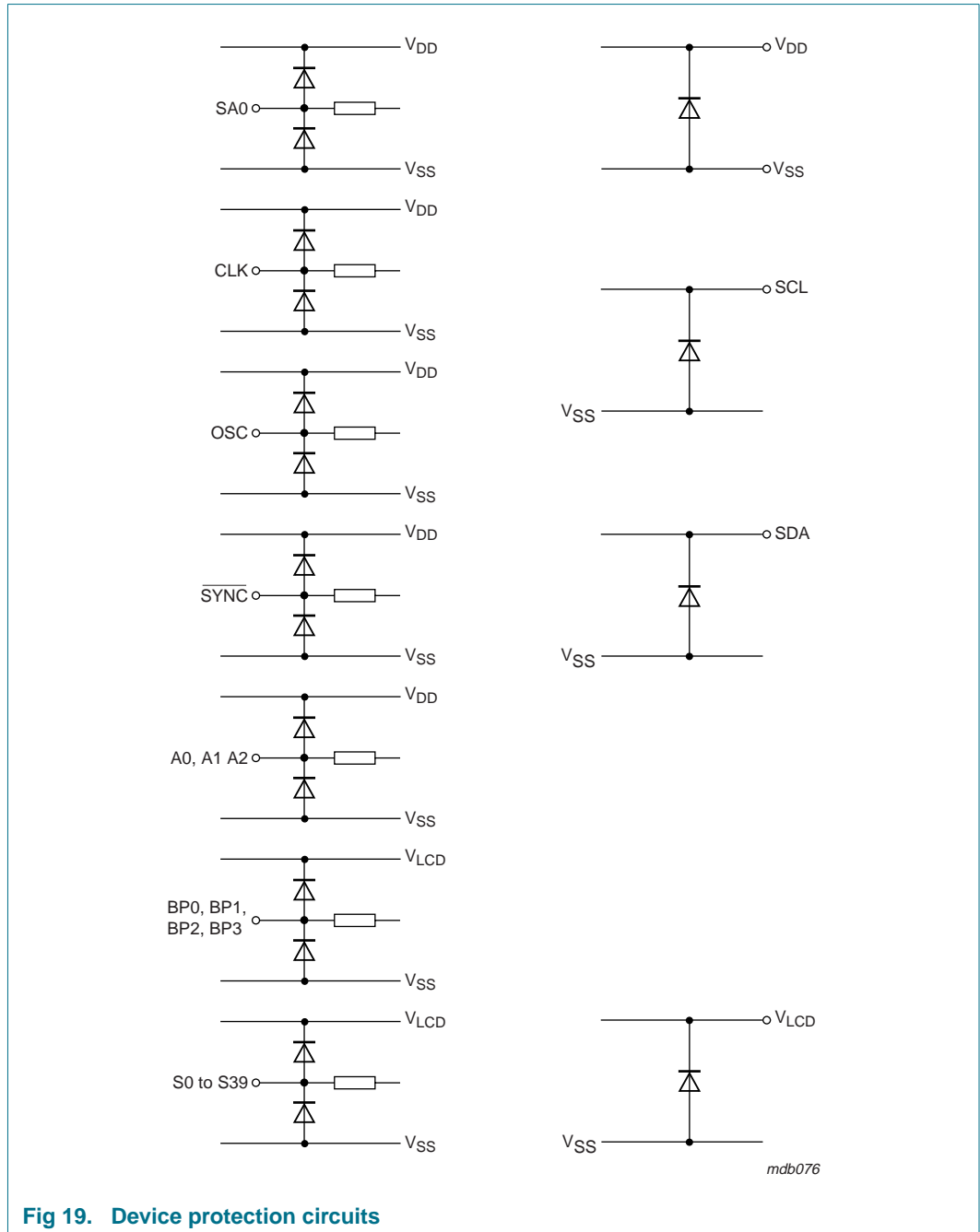

## 9. Limiting values

### CAUTION



Static voltages across the liquid crystal display can build up when the LCD supply voltage ( $V_{LCD}$ ) is on while the IC supply voltage ( $V_{DD}$ ) is off, or vice versa. This may cause unwanted display artifacts. To avoid such artifacts,  $V_{LCD}$  and  $V_{DD}$  must be applied or removed together.

**Table 14. Limiting values**

In accordance with the Absolute Maximum Rating System (IEC 60134).

| Symbol        | Parameter                       | Conditions  | Min  | Max  | Unit  |    |
|---------------|---------------------------------|---|------|------|-------|----|
| $V_{DD}$      | supply voltage                  |   | -0.5 | 6.5  | V     |    |
| $V_{LCD}$     | LCD supply voltage              |   | -0.5 | +7.5 | V     |    |
| $V_I$         | input voltage                   | on each of the pins CLK, SDA, SCL, SYNC, SA0, OSC, A0 to A2 | -0.5 | +6.5 | V     |    |
| $V_O$         | output voltage                  | on each of the pins S0 to S39, BP0 to BP3                   | -0.5 | +7.5 | V     |    |
| $I_I$         | input current                   |   | -10  | +10  | mA    |    |
| $I_O$         | output current                  |   | -10  | +10  | mA    |    |
| $I_{DD}$      | supply current                  |   | -50  | +50  | mA    |    |
| $I_{DD(LCD)}$ | LCD supply current              |   | -50  | +50  | mA    |    |
| $I_{SS}$      | ground supply current           |   | -50  | +50  | mA    |    |
| $P_{tot}$     | total power dissipation         |   | -    | 400  | mW    |    |
| $P_o$         | output power                    |   | -    | 100  | mW    |    |
| $V_{esd}$     | electrostatic discharge voltage | HBM   | [1]  | -    | ±5000 | V  |
|               |                                 | MM  | [2]  | -    | ±200  | V  |
|               |                                 | CDM   | [3]  | -    | ±1000 | V  |
| $I_{lu}$      | latch-up current                |   | [4]  | -    | 100   | mA |
| $T_{stg}$     | storage temperature             |   | [5]  | -65  | +150  | °C |

[1] Pass level; Human Body Model (HBM) according to JESD22-A114.

[2] Pass level; Machine Model (MM), according to JESD22-A115.

[3] Pass level; Charged-Device Model (CDM), according to JESD22-C101.

[4] Pass level; latch-up testing, according to JESD78.

[5] According to the NXP store and transport conditions (document SNW-SQ-623) the devices have to be stored at a temperature of +5 °C to +45 °C and a humidity of 25 % to 75 %.

## 10. Static characteristics

**Table 15. Static characteristics**

$V_{DD} = 1.8\text{ V to }5.5\text{ V}$ ;  $V_{SS} = 0\text{ V}$ ;  $V_{LCD} = 2.5\text{ V to }6.5\text{ V}$ ;  $T_{amb} = -40\text{ °C to }+85\text{ °C}$ ; unless otherwise specified.

| Symbol          | Parameter          | Conditions | Min | Typ | Max | Unit |
|-----------------|--------------------|------------|-----|-----|-----|------|
| <b>Supplies</b> |                    |            |     |     |     |      |
| $V_{DD}$        | supply voltage     |            | 1.8 | -   | 5.5 | V    |
| $V_{LCD}$       | LCD supply voltage | [1]        | 2.5 | -   | 6.5 | V    |

**Table 15. Static characteristics ...continued**

$V_{DD} = 1.8\text{ V to }5.5\text{ V}$ ;  $V_{SS} = 0\text{ V}$ ;  $V_{LCD} = 2.5\text{ V to }6.5\text{ V}$ ;  $T_{amb} = -40\text{ }^{\circ}\text{C to }+85\text{ }^{\circ}\text{C}$ ; unless otherwise specified.

| Symbol             | Parameter                            | Conditions  | Min                | Typ | Max         | Unit          |
|--------------------|--------------------------------------|---|--------------------|-----|-------------|---------------|
| $I_{DD}$           | supply current                       | $f_{clk} = 1536\text{ Hz}$ [2]  | -                  | 8   | 20          | $\mu\text{A}$ |
| $I_{DD(LCD)}$      | LCD supply current                   | $f_{clk} = 1536\text{ Hz}$ [2]  | -                  | 24  | 60          | $\mu\text{A}$ |
| <b>Logic</b>       |                                      |   |                    |     |             |               |
| $V_{P(POR)}$       | power-on reset supply voltage        |   | 1.0                | 1.3 | 1.6         | V             |
| $V_{IL}$           | LOW-level input voltage              | on pins CLK, $\overline{\text{SYNC}}$ , OSC, A0 to A2, SA0, SCL, SDA    | $V_{SS}$           | -   | $0.3V_{DD}$ | V             |
| $V_{IH}$           | HIGH-level input voltage             | on pins CLK, $\overline{\text{SYNC}}$ , OSC, A0 to A2, SA0, SCL, SDA    | [3][4] $0.7V_{DD}$ | -   | $V_{DD}$    | V             |
| $I_{OL}$           | LOW-level output current             | $V_{OL} = 0.4\text{ V}$ ; $V_{DD} = 5\text{ V}$                         |                    |     |             |               |
|                    |                                      | on pins CLK and $\overline{\text{SYNC}}$                                | 1                  | -   | -           | mA            |
|                    |                                      | on pin SDA  | 3                  | -   | -           | mA            |
| $I_{OH(CLK)}$      | HIGH-level output current on pin CLK | $V_{OH} = 4.6\text{ V}$ ; $V_{DD} = 5\text{ V}$                         | -1                 | -   | -           | mA            |
| $I_L$              | leakage current                      | $V_I = V_{DD}$ or $V_{SS}$ ;<br>on pins CLK, SCL, SDA, A0 to A2 and SA0 | -1                 | -   | +1          | $\mu\text{A}$ |
| $I_{L(OSC)}$       | leakage current on pin OSC           | $V_I = V_{DD}$  | -1                 | -   | +1          | $\mu\text{A}$ |
| $C_I$              | input capacitance                    |   | [5] -              | -   | 7           | pF            |
| <b>LCD outputs</b> |                                      |   |                    |     |             |               |
| $\Delta V_O$       | output voltage variation             | on pins BP0 - BP3 and S0 - S39  | -100               | -   | +100        | mV            |
| $R_O$              | output resistance                    | $V_{LCD} = 5\text{ V}$ [6]  |                    |     |             |               |
|                    |                                      | on pins BP0 to BP3  | -                  | 1.5 | -           | k $\Omega$    |
|                    |                                      | on pins S0 to S39   | -                  | 6.0 | -           | k $\Omega$    |

[1]  $V_{LCD} > 3\text{ V}$  for  $\frac{1}{3}$  bias.

[2] LCD outputs are open-circuit; inputs at  $V_{SS}$  or  $V_{DD}$ ; external clock with 50 % duty factor; I<sup>2</sup>C-bus inactive.

[3] When tested, I<sup>2</sup>C pins SCL and SDA have no diode to  $V_{DD}$  and may be driven to the  $V_I$  limiting values given in Table 14 (see Figure 19 too).

[4] Propagation delay of driver between clock (CLK) and LCD driving signals.

[5] Periodically sampled, not 100 % tested.

[6] Outputs measured one at a time.

## 11. Dynamic characteristics

**Table 16. Dynamic characteristics**

$V_{DD} = 1.8\text{ V to }5.5\text{ V}$ ;  $V_{SS} = 0\text{ V}$ ;  $V_{LCD} = 2.5\text{ V to }6.5\text{ V}$ ;  $T_{amb} = -40\text{ }^{\circ}\text{C to }+85\text{ }^{\circ}\text{C}$ ; unless otherwise specified.

| Symbol                       | Parameter  | Conditions                        | Min  | Typ  | Max  | Unit          |
|------------------------------|--|-----------------------------------|------|------|------|---------------|
| <b>Clock</b>                 |  |                                   |      |      |      |               |
| $f_{\text{clk(int)}}$        | internal clock frequency                         | [1]                               | 1440 | 1536 | 2640 | Hz            |
| $f_{\text{clk(ext)}}$        | external clock frequency                         |                                   | 960  | -    | 2640 | Hz            |
| $t_{\text{clk(H)}}$          | HIGH-level clock time                            |                                   | 60   | -    | -    | $\mu\text{s}$ |
| $t_{\text{clk(L)}}$          | LOW-level clock time                             |                                   | 60   | -    | -    | $\mu\text{s}$ |
| <b>Synchronization</b>       |  |                                   |      |      |      |               |
| $t_{\text{PD(SYNC\_N)}}$     | $\overline{\text{SYNC}}$ propagation delay       |                                   | -    | 30   | -    | ns            |
| $t_{\text{SYNC\_NL}}$        | $\overline{\text{SYNC}}$ LOW time                |                                   | 1    | -    | -    | $\mu\text{s}$ |
| $t_{\text{PD(drv)}}$         | driver propagation delay                         | $V_{\text{LCD}} = 5\text{ V}$ [2] | -    | -    | 30   | $\mu\text{s}$ |
| <b>I<sup>2</sup>C-bus[3]</b> |  |                                   |      |      |      |               |
| <b>Pin SCL</b>               |  |                                   |      |      |      |               |
| $f_{\text{SCL}}$             | SCL clock frequency                              |                                   | -    | -    | 400  | kHz           |
| $t_{\text{LOW}}$             | LOW period of the SCL clock                      |                                   | 1.3  | -    | -    | $\mu\text{s}$ |
| $t_{\text{HIGH}}$            | HIGH period of the SCL clock                     |                                   | 0.6  | -    | -    | $\mu\text{s}$ |
| <b>Pin SDA</b>               |  |                                   |      |      |      |               |
| $t_{\text{SU;DAT}}$          | data set-up time                                 |                                   | 100  | -    | -    | ns            |
| $t_{\text{HD;DAT}}$          | data hold time                                   |                                   | 0    | -    | -    | ns            |
| <b>Pins SCL and SDA</b>      |  |                                   |      |      |      |               |
| $t_{\text{BUF}}$             | bus free time between a STOP and START condition |                                   | 1.3  | -    | -    | $\mu\text{s}$ |
| $t_{\text{SU;STO}}$          | set-up time for STOP condition                   |                                   | 0.6  | -    | -    | $\mu\text{s}$ |
| $t_{\text{HD;STA}}$          | hold time (repeated) START condition             |                                   | 0.6  | -    | -    | $\mu\text{s}$ |
| $t_{\text{SU;STA}}$          | set-up time for a repeated START condition       |                                   | 0.6  | -    | -    | $\mu\text{s}$ |
| $t_{\text{r}}$               | rise time of both SDA and SCL signals            | $f_{\text{SCL}} = 400\text{ kHz}$ | -    | -    | 0.3  | $\mu\text{s}$ |
|                              |  | $f_{\text{SCL}} < 125\text{ kHz}$ | -    | -    | 1.0  | $\mu\text{s}$ |
| $t_{\text{f}}$               | fall time of both SDA and SCL signals            |                                   | -    | -    | 0.3  | $\mu\text{s}$ |
| $C_{\text{b}}$               | capacitive load for each bus line                |                                   | -    | -    | 400  | pF            |
| $t_{\text{w(spike)}}$        | spike pulse width                                | on the I <sup>2</sup> C-bus       | -    | -    | 50   | ns            |

[1] Typical output duty factor: 50 % measured at the CLK output pin.

[2] Not tested in production.

[3] All timing values are valid within the operating supply voltage and ambient temperature range and are referenced to  $V_{\text{IL}}$  and  $V_{\text{IH}}$  with an input voltage swing of  $V_{\text{SS}}$  to  $V_{\text{DD}}$ .

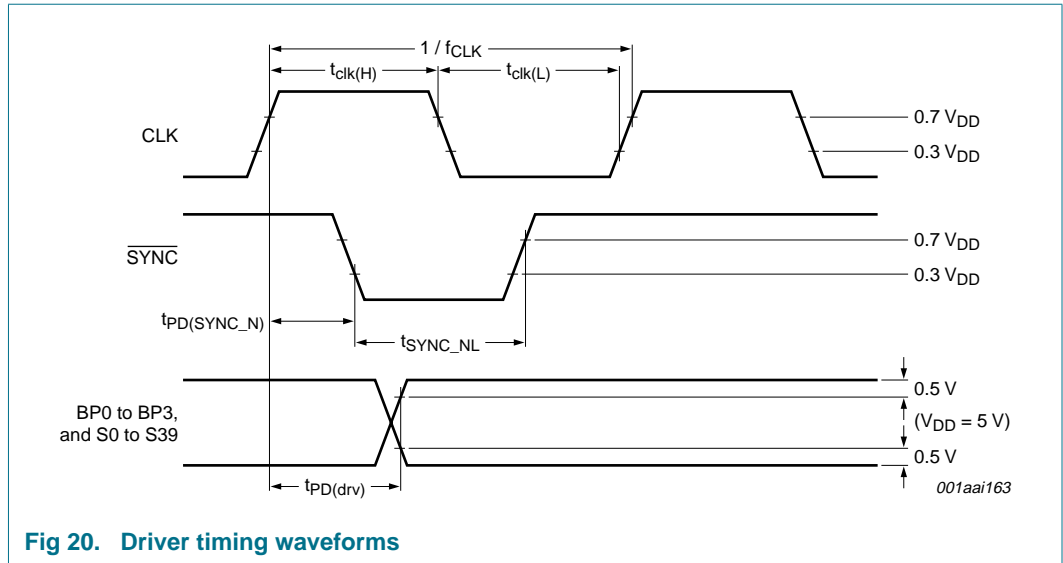

Fig 20. Driver timing waveforms

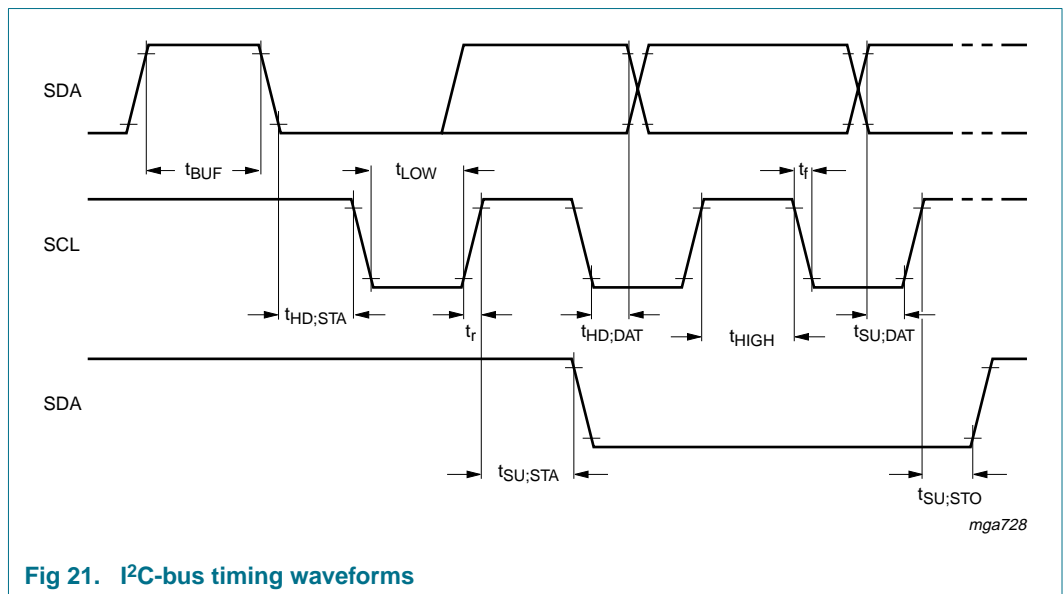

Fig 21. I<sup>2</sup>C-bus timing waveforms



## 12. Application information

### 12.1 Cascaded operation

In large display configurations, up to 16 PCF8576Ds can be differentiated on the same I<sup>2</sup>C-bus by using the 3-bit hardware subaddresses (A0, A1 and A2) and the programmable I<sup>2</sup>C-bus slave address (SA0).

**Table 17. Addressing cascaded PCF8576D**

| Cluster | Bit SA0 | Pin A2 | Pin A1 | Pin A0 | Device |
|---------|---------|--------|--------|--------|--------|
| 1       | 0       | 0      | 0      | 0      | 0      |
|         |         | 0      | 0      | 1      | 1      |
|         |         | 0      | 1      | 0      | 2      |
|         |         | 0      | 1      | 1      | 3      |
|         |         | 1      | 0      | 0      | 4      |
|         |         | 1      | 0      | 1      | 5      |
|         |         | 1      | 1      | 0      | 6      |
|         |         | 1      | 1      | 1      | 7      |
| 2       | 1       | 0      | 0      | 0      | 8      |
|         |         | 0      | 0      | 1      | 9      |
|         |         | 0      | 1      | 0      | 10     |
|         |         | 0      | 1      | 1      | 11     |
|         |         | 1      | 0      | 0      | 12     |
|         |         | 1      | 0      | 1      | 13     |
|         |         | 1      | 1      | 0      | 14     |
|         |         | 1      | 1      | 1      | 15     |

PCF8576Ds connected in cascade are synchronized to allow the backplane signals from only one device in the cascade to be shared. This arrangement is cost-effective in large LCD applications since the backplane outputs of only one device need to be through-plated to the backplane electrodes of the display. The other cascaded PCF8576Ds contribute additional segment outputs but their backplane outputs are left open-circuit (see [Figure 22](#)).

All PCF8576Ds connected in cascade are correctly synchronized by the  $\overline{\text{SYNC}}$  signal. This synchronization is guaranteed after the power-on reset. The only time that  $\overline{\text{SYNC}}$  is likely to be needed is if synchronization is lost accidentally, for example, by noise in adverse electrical environments, or if the LCD multiplex drive mode is changed in an application using several cascaded PCF8576Ds, as the drive mode cannot be changed on all of the cascaded devices simultaneously.  $\overline{\text{SYNC}}$  can be either an input or an output signal; a  $\overline{\text{SYNC}}$  output is implemented as an open-drain driver with an internal pull-up resistor. The PCF8576D asserts  $\overline{\text{SYNC}}$  at the start of its last active backplane signal and monitors the  $\overline{\text{SYNC}}$  line at all other times. If cascade synchronization is lost, it is restored by the first PCF8576D to assert  $\overline{\text{SYNC}}$ . The timing relationship between the backplane waveforms and the  $\overline{\text{SYNC}}$  signal for each LCD drive mode is shown in [Figure 23](#).

The contact resistance between the  $\overline{\text{SYNC}}$  on each cascaded device must be controlled. If the resistance is too high, the device is not able to synchronize properly; this is particularly applicable to chip-on-glass applications. The maximum  $\overline{\text{SYNC}}$  contact resistance allowed for the number of devices in cascade is given in [Table 18](#).

**Table 18.**  $\overline{\text{SYNC}}$  contact resistance

| Number of devices | Maximum contact resistance |
|-------------------|----------------------------|
| 2                 | 6 k $\Omega$               |
| 3 to 5            | 2.2 k $\Omega$             |
| 6 to 10           | 1.2 k $\Omega$             |
| 10 to 16          | 700 $\Omega$               |

The PCF8576D can be cascaded with the PCF8562, the PCF8533 or the PCF8534A. This allows optimal drive selection for a given number of pixels to display. [Figure 20](#) and [Figure 21](#) show the timing of the synchronization signals.

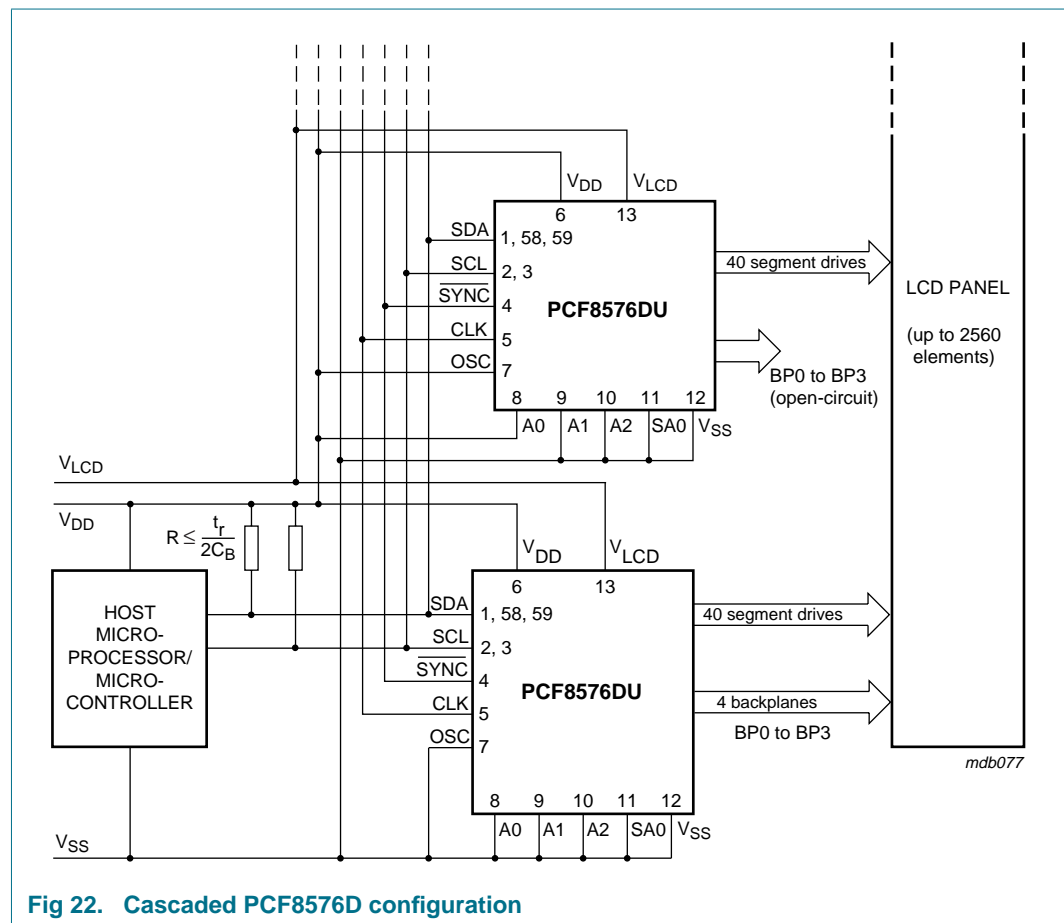

**Fig 22.** Cascaded PCF8576D configuration

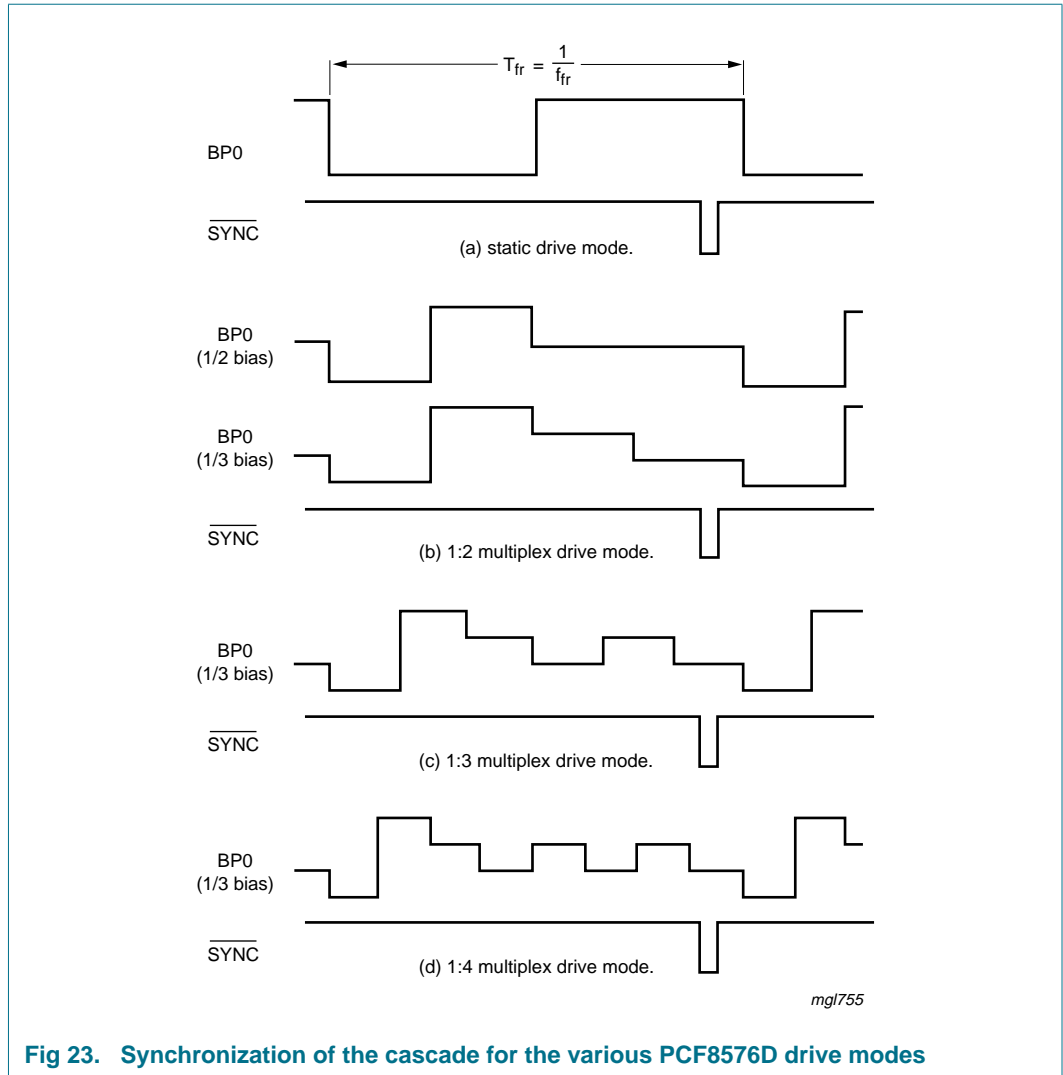

### 13. Package outline

TQFP64: plastic thin quad flat package; 64 leads; body 10 x 10 x 1.0 mm

SOT357-1

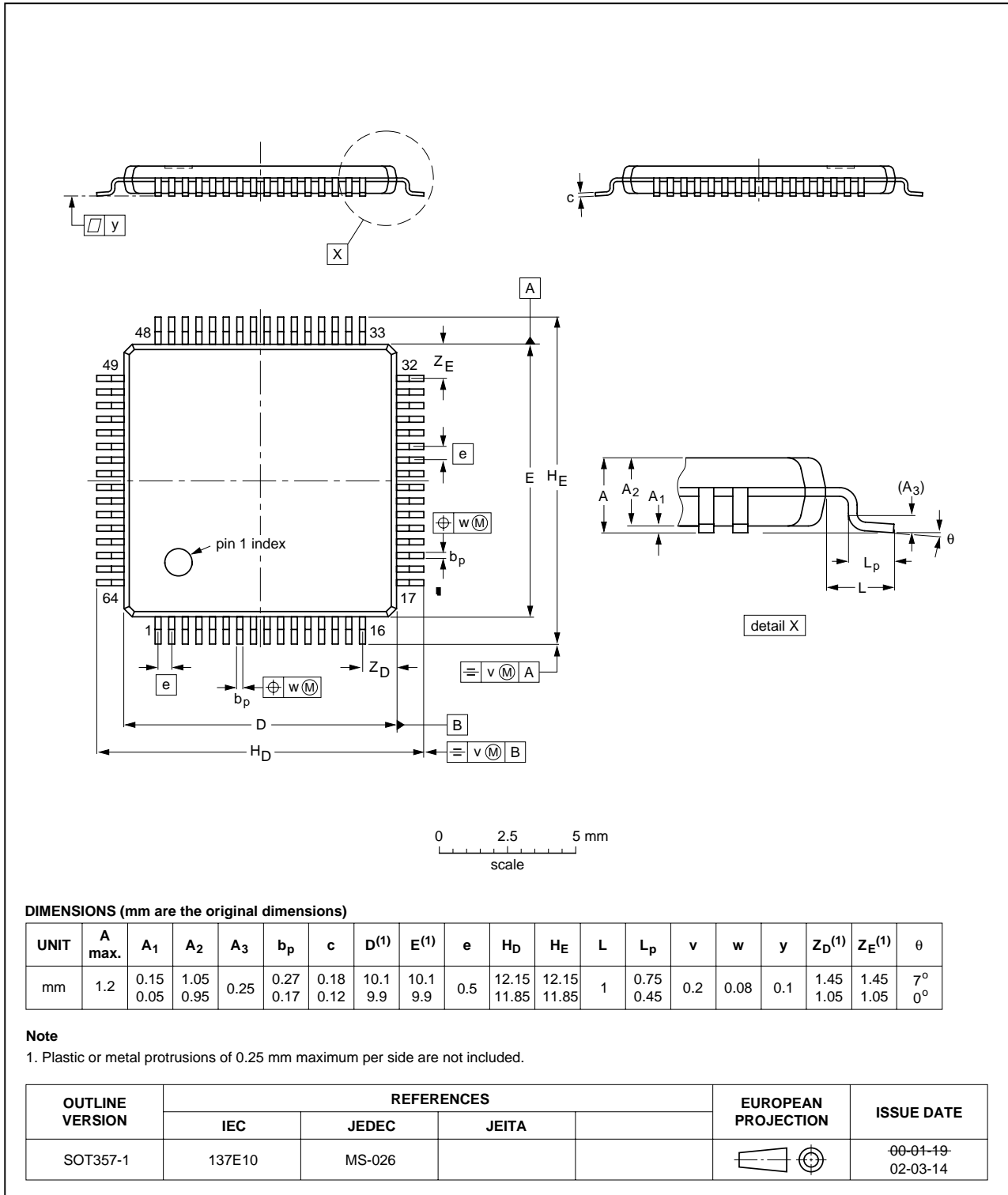

Fig 24. Package outline SOT357-1 (TQFP64)

TSSOP56: plastic thin shrink small outline package; 56 leads; body width 6.1 mm

SOT364-1

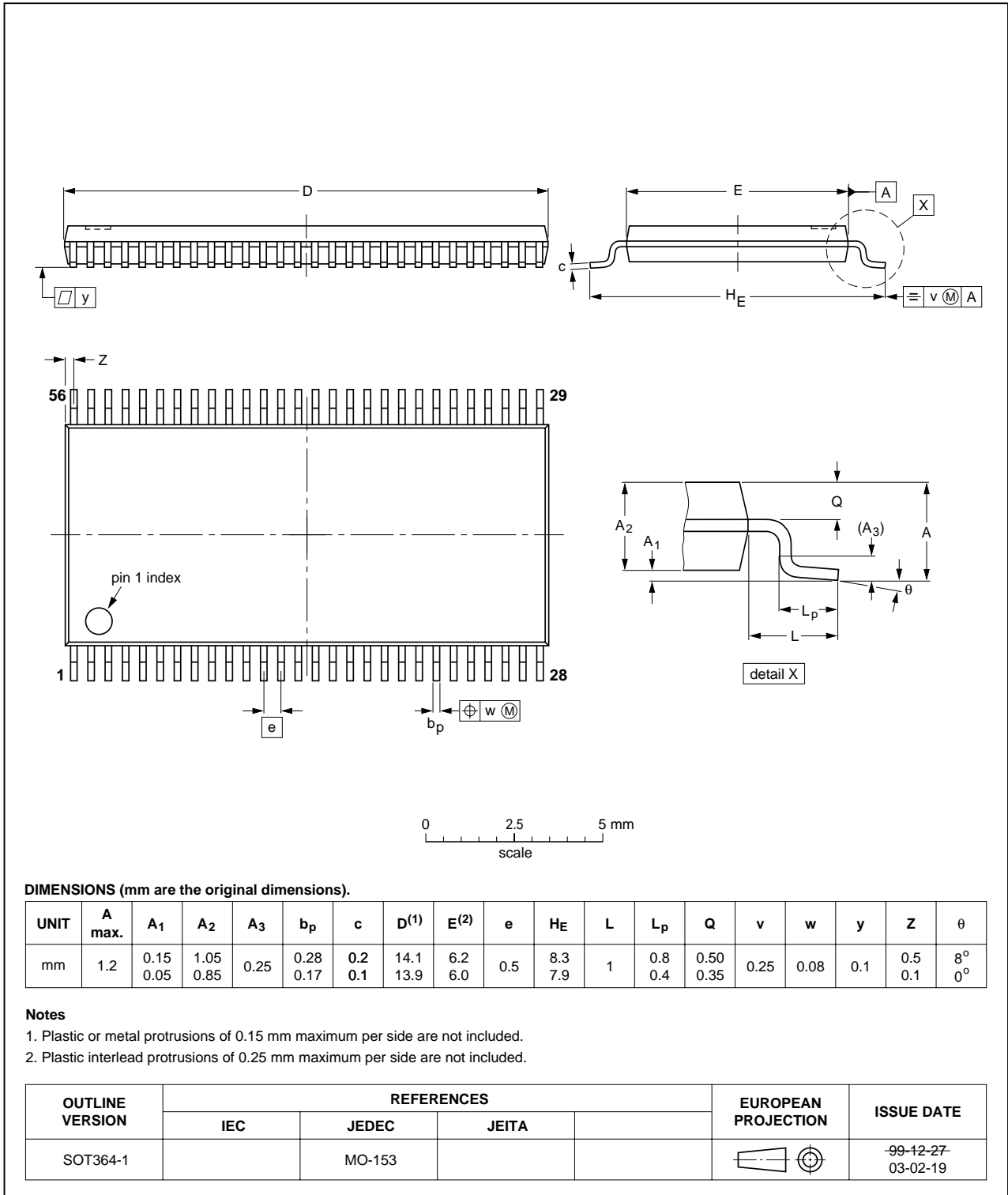

Fig 25. Package outline SOT364-1 (TSSOP56)

14. Bare die outline

Wire bond die; 59 bonding pads; 2.26 x 2.01 x 0.38 mm

PCF8576DU/DA

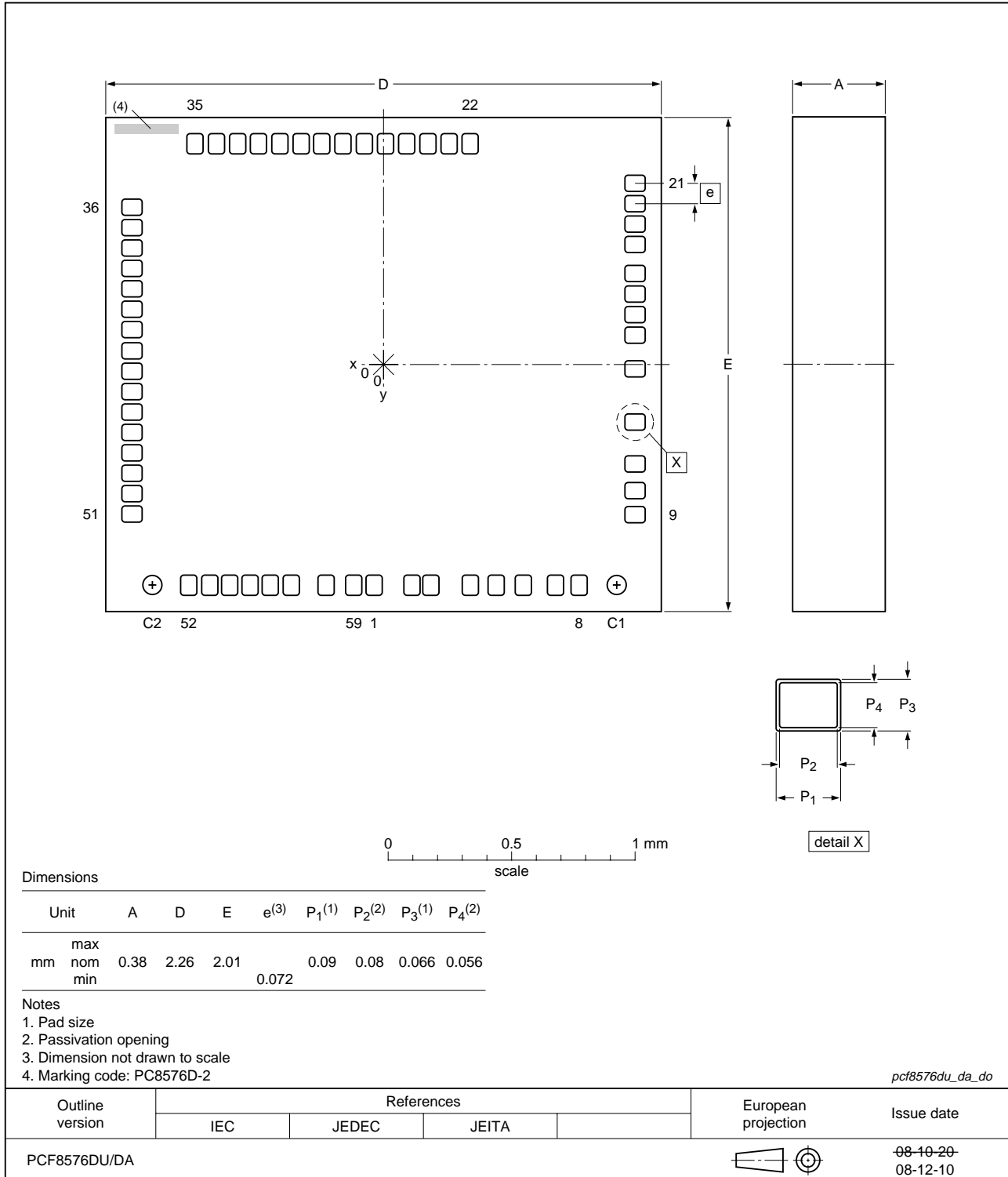

Fig 26. Bare die outline PCF8576DU/DA/2

Bare die; 59 bumps; 2.26 x 2.01 x 0.40 mm

PCF8576DU/2DA

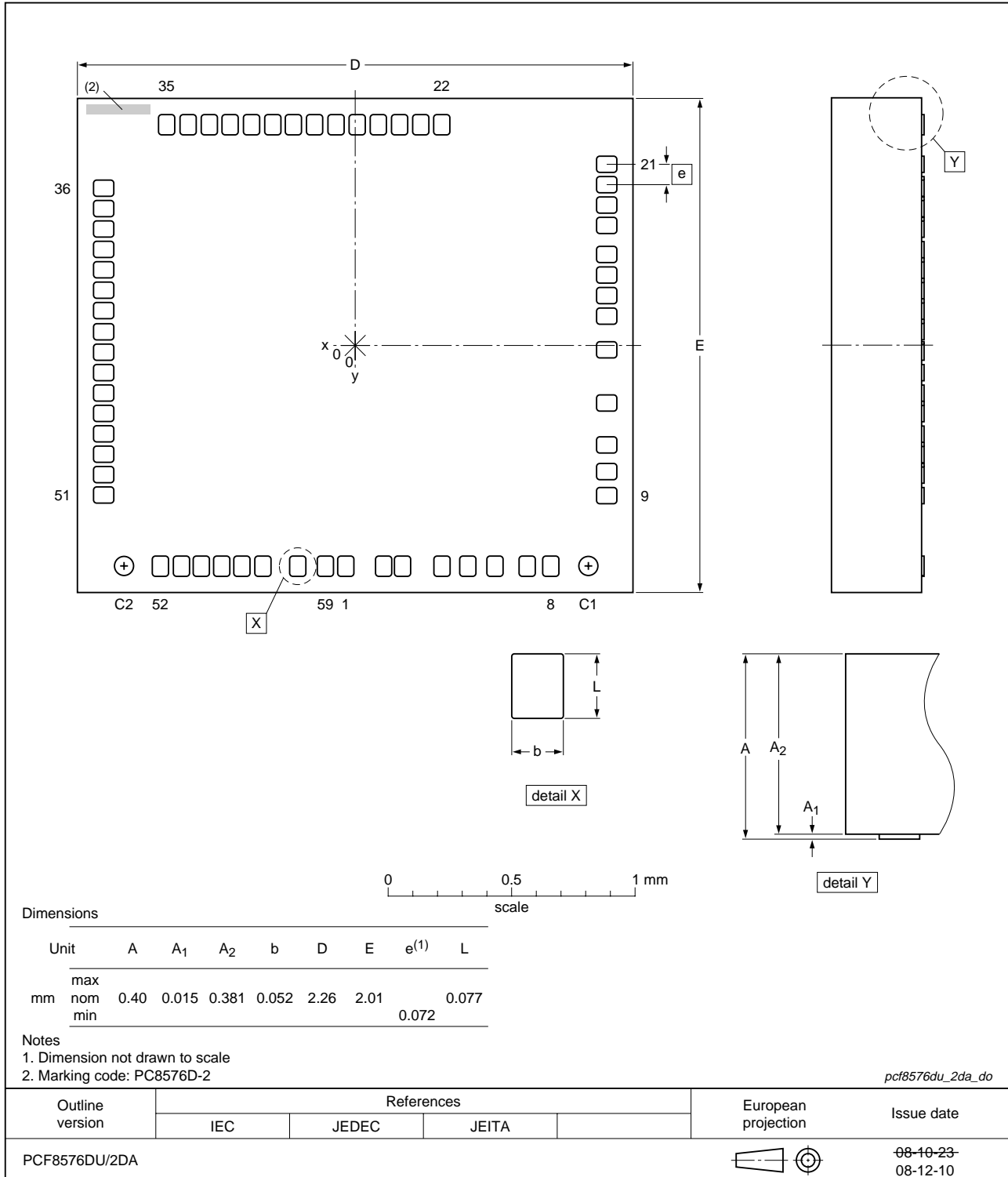

Fig 27. Bare die outline PCF8576DU/2DA/2

**Table 19. Bonding pad location for PCF8576DUx**

All x/y coordinates represent the position of the center of each pad with respect to the center (x/y = 0) of the chip (see [Figure 4](#), [Figure 26](#) and [Figure 27](#)).

| Symbol           | Pad | X (μm)  | Y (μm) | Description                                   |
|------------------|-----|---------|--------|---|
| SDA              | 1   | -34.38  | -876.6 | I <sup>2</sup> C-bus serial data input/output |
| SCL              | 2   | 109.53  | -876.6 | I <sup>2</sup> C-bus serial clock input       |
| SCL              | 3   | 181.53  | -876.6 |   |
| SYNC             | 4   | 365.58  | -876.6 | cascade synchronization input/output          |
| CLK              | 5   | 469.08  | -876.6 | external clock input/output                   |
| V <sub>DD</sub>  | 6   | 577.08  | -876.6 | supply voltage                                |
| OSC              | 7   | 740.88  | -876.6 | internal oscillator enable input              |
| A0               | 8   | 835.83  | -876.6 | subaddress inputs                             |
| A1               | 9   | 1005.48 | -630.9 |   |
| A2               | 10  | 1005.48 | -513.9 |   |
| SA0              | 11  | 1005.48 | -396.9 | I <sup>2</sup> C-bus address input; bit 0     |
| V <sub>SS</sub>  | 12  | 1005.48 | -221.4 | ground supply voltage                         |
| V <sub>LCD</sub> | 13  | 1005.48 | 10.71  | LCD supply voltage                            |
| BP0              | 14  | 1005.48 | 156.51 | LCD backplane outputs                         |
| BP2              | 15  | 1005.48 | 232.74 |   |
| BP1              | 16  | 1005.48 | 308.97 |   |
| BP3              | 17  | 1005.48 | 385.2  |   |
| S0               | 18  | 1005.48 | 493.2  | LCD segment outputs                           |
| S1               | 19  | 1005.48 | 565.2  |   |
| S2               | 20  | 1005.48 | 637.2  |   |
| S3               | 21  | 1005.48 | 709.2  |   |
| S4               | 22  | 347.22  | 876.6  |   |
| S5               | 23  | 263.97  | 876.6  |   |
| S6               | 24  | 180.72  | 876.6  |   |
| S7               | 25  | 97.47   | 876.6  |   |
| S8               | 26  | 14.22   | 876.6  |   |
| S9               | 27  | -69.03  | 876.6  |   |
| S10              | 28  | -152.28 | 876.6  |   |
| S11              | 29  | -235.53 | 876.6  |   |
| S12              | 30  | -318.78 | 876.6  |   |
| S13              | 31  | -402.03 | 876.6  |   |
| S14              | 32  | -485.28 | 876.6  |   |
| S15              | 33  | -568.53 | 876.6  |   |
| S16              | 34  | -651.78 | 876.6  |   |
| S17              | 35  | -735.03 | 876.6  |   |
| S18              | 36  | -1005.5 | 625.59 |   |
| S19              | 37  | -1005.5 | 541.62 |   |
| S20              | 38  | -1005.5 | 458.19 |   |
| S21              | 39  | -1005.5 | 374.76 |   |



**Table 19. Bonding pad location for PCF8576DUx ...continued**

All x/y coordinates represent the position of the center of each pad with respect to the center (x/y = 0) of the chip (see [Figure 4](#), [Figure 26](#) and [Figure 27](#)).

| Symbol | Pad | X (μm)  | Y (μm) | Description                                   |
|--------|-----|---------|--------|---|
| S22    | 40  | -1005.5 | 291.33 | LCD segment outputs                           |
| S23    | 41  | -1005.5 | 207.9  |   |
| S24    | 42  | -1005.5 | 124.47 |   |
| S25    | 43  | -1005.5 | 41.04  |   |
| S26    | 44  | -1005.5 | -42.39 |   |
| S27    | 45  | -1005.5 | -125.8 |   |
| S28    | 46  | -1005.5 | -209.3 |   |
| S29    | 47  | -1005.5 | -292.7 |   |
| S30    | 48  | -1005.5 | -376.1 |   |
| S31    | 49  | -1005.5 | -459.5 |   |
| S32    | 50  | -1005.5 | -543   |   |
| S33    | 51  | -1005.5 | -625.6 |   |
| S34    | 52  | -735.03 | -876.6 |   |
| S35    | 53  | -663.03 | -876.6 |   |
| S36    | 54  | -591.03 | -876.6 |   |
| S37    | 55  | -519.03 | -876.6 |   |
| S38    | 56  | -447.03 | -876.6 |   |
| S39    | 57  | -375.03 | -876.6 |   |
| SDA    | 58  | -196.38 | -876.6 | I <sup>2</sup> C-bus serial data input/output |
| SDA    | 59  | -106.38 | -876.6 |   |

**Table 20. Alignment marks**

All x/y coordinates represent the position of the center of each alignment mark with respect to the center (x/y = 0) of the chip (see [Figure 4](#), [Figure 26](#) and [Figure 27](#)).

| Symbol | X (μm)  | Y (μm) |
|--------|---------|--------|
| C1     | 930.42  | -870.3 |
| C2     | -829.98 | -870.3 |

## 15. Handling information

Inputs and outputs are protected against electrostatic discharge in normal handling. However, to be completely safe you must take normal precautions appropriate to handling MOS devices; see *JESD625-A* and/or *IEC61340-5*.

## 16. Packing information

### 16.1 Tray information

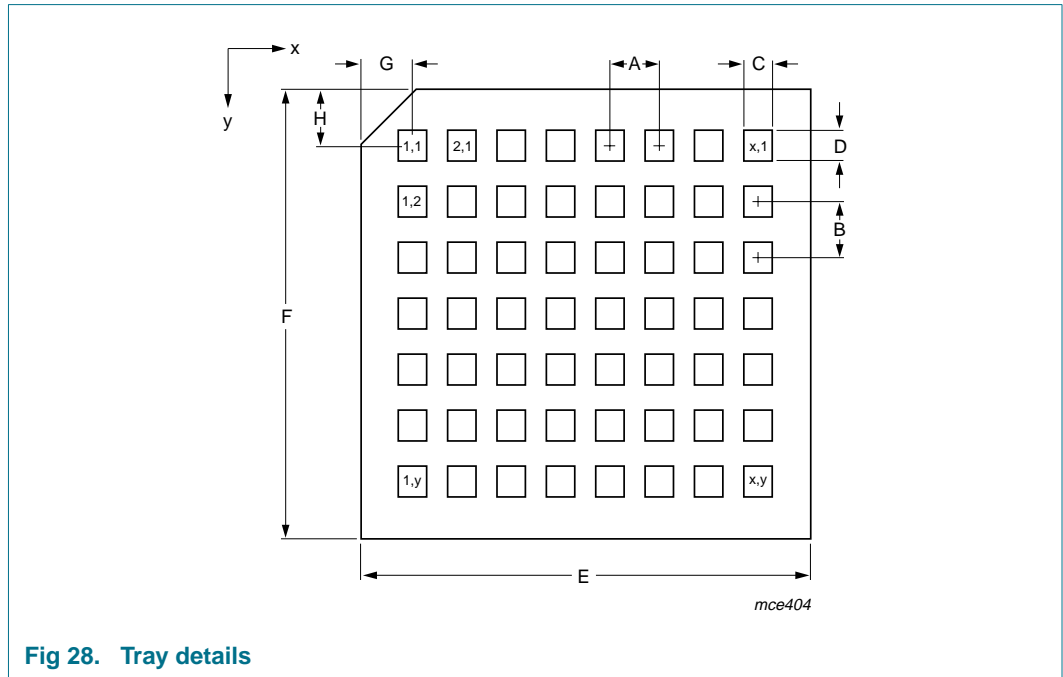

Fig 28. Tray details

Table 21. Tray dimensions (see [Figure 28](#))

| Symbol | Description                     | Value | Unit |
|--------|---------------------------------|-------|------|
| A      | pocket pitch in x direction     | 5.59  | mm   |
| B      | pocket pitch in y direction     | 6.35  | mm   |
| C      | pocket width in x direction     | 3.16  | mm   |
| D      | pocket width in y direction     | 3.16  | mm   |
| E      | tray width in x direction       | 50.8  | mm   |
| F      | tray width in y direction       | 50.8  | mm   |
| G      | cut corner to pocket 1.1 center | 5.83  | mm   |
| H      | cut corner to pocket 1.1 center | 6.35  | mm   |
| x      | number of pockets, x direction  | 8     | -    |
| y      | number of pockets, y direction  | 7     | -    |

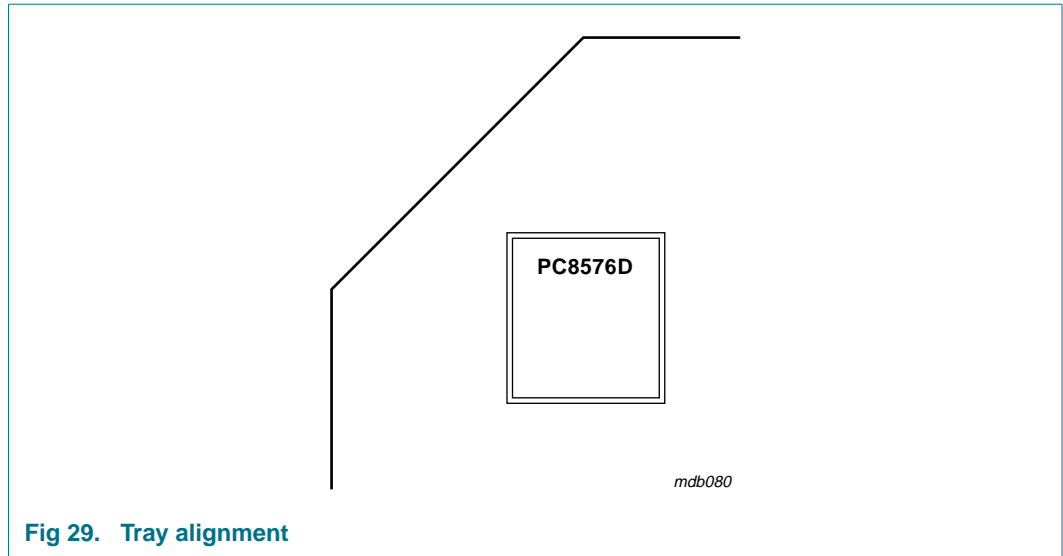

Fig 29. Tray alignment

### 16.2 Carrier tape information

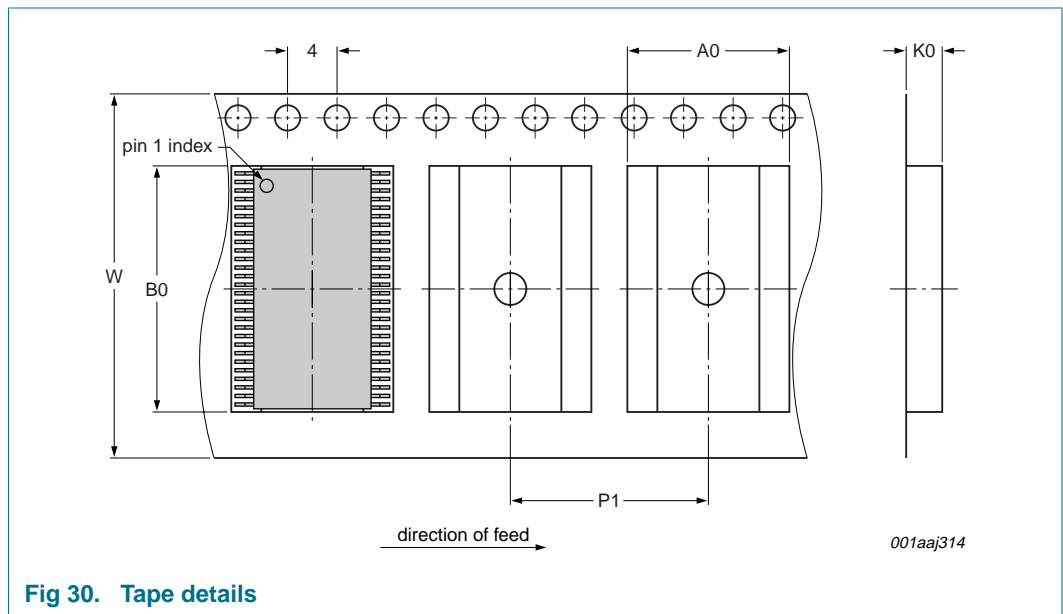

Fig 30. Tape details

Table 22. Carrier tape dimensions

| Symbol | Description                 | Value | Unit |
|--------|-----------------------------|-------|------|
| A0     | pocket width in x direction | 8.6   | mm   |
| B0     | pocket width in y direction | 14.5  | mm   |
| K0     | pocket height               | 1.8   | mm   |
| P1     | sprocket hole pitch         | 12    | mm   |
| W      | tape width in y direction   | 24    | mm   |

## 17. Soldering of SMD packages

This text provides a very brief insight into a complex technology. A more in-depth account of soldering ICs can be found in Application Note *AN10365 "Surface mount reflow soldering description"*.

### 17.1 Introduction to soldering

Soldering is one of the most common methods through which packages are attached to Printed Circuit Boards (PCBs), to form electrical circuits. The soldered joint provides both the mechanical and the electrical connection. There is no single soldering method that is ideal for all IC packages. Wave soldering is often preferred when through-hole and Surface Mount Devices (SMDs) are mixed on one printed wiring board; however, it is not suitable for fine pitch SMDs. Reflow soldering is ideal for the small pitches and high densities that come with increased miniaturization.

### 17.2 Wave and reflow soldering

Wave soldering is a joining technology in which the joints are made by solder coming from a standing wave of liquid solder. The wave soldering process is suitable for the following:

- Through-hole components
- Leaded or leadless SMDs, which are glued to the surface of the printed circuit board

Not all SMDs can be wave soldered. Packages with solder balls, and some leadless packages which have solder lands underneath the body, cannot be wave soldered. Also, leaded SMDs with leads having a pitch smaller than ~0.6 mm cannot be wave soldered, due to an increased probability of bridging.

The reflow soldering process involves applying solder paste to a board, followed by component placement and exposure to a temperature profile. Leaded packages, packages with solder balls, and leadless packages are all reflow solderable.

Key characteristics in both wave and reflow soldering are:

- Board specifications, including the board finish, solder masks and vias
- Package footprints, including solder thieves and orientation
- The moisture sensitivity level of the packages
- Package placement
- Inspection and repair
- Lead-free soldering versus SnPb soldering

### 17.3 Wave soldering

Key characteristics in wave soldering are:

- Process issues, such as application of adhesive and flux, clinching of leads, board transport, the solder wave parameters, and the time during which components are exposed to the wave
- Solder bath specifications, including temperature and impurities

### 17.4 Reflow soldering

Key characteristics in reflow soldering are:

- Lead-free versus SnPb soldering; note that a lead-free reflow process usually leads to higher minimum peak temperatures (see [Figure 31](#)) than a SnPb process, thus reducing the process window
- Solder paste printing issues including smearing, release, and adjusting the process window for a mix of large and small components on one board
- Reflow temperature profile; this profile includes preheat, reflow (in which the board is heated to the peak temperature) and cooling down. It is imperative that the peak temperature is high enough for the solder to make reliable solder joints (a solder paste characteristic). In addition, the peak temperature must be low enough that the packages and/or boards are not damaged. The peak temperature of the package depends on package thickness and volume and is classified in accordance with [Table 23](#) and [24](#)

**Table 23. SnPb eutectic process (from J-STD-020C)**

| Package thickness (mm) | Package reflow temperature (°C) |       |
|------------------------|---------------------------------|-------|
|                        | Volume (mm <sup>3</sup> )       |       |
|                        | < 350                           | ≥ 350 |
| < 2.5                  | 235                             | 220   |
| ≥ 2.5                  | 220                             | 220   |

**Table 24. Lead-free process (from J-STD-020C)**

| Package thickness (mm) | Package reflow temperature (°C) |             |        |
|------------------------|---------------------------------|-------------|--------|
|                        | Volume (mm <sup>3</sup> )       |             |        |
|                        | < 350                           | 350 to 2000 | > 2000 |
| < 1.6                  | 260                             | 260         | 260    |
| 1.6 to 2.5             | 260                             | 250         | 245    |
| > 2.5                  | 250                             | 245         | 245    |

Moisture sensitivity precautions, as indicated on the packing, must be respected at all times.

Studies have shown that small packages reach higher temperatures during reflow soldering, see [Figure 31](#).

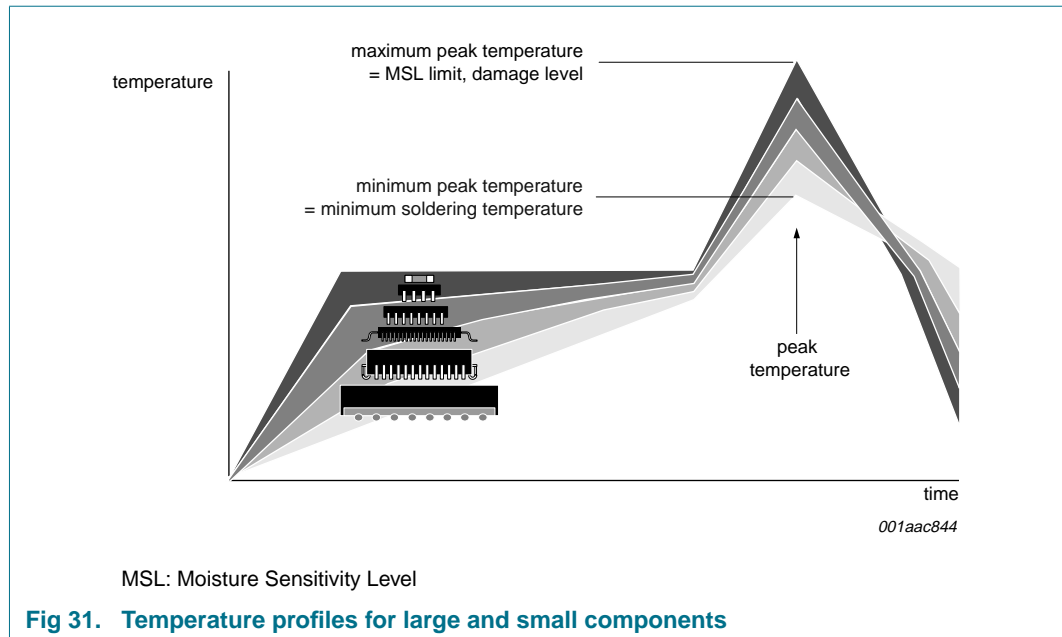

For further information on temperature profiles, refer to Application Note *AN10365 "Surface mount reflow soldering description"*.

## 18. Soldering of WLCSP packages

### 18.1 Introduction to soldering WLCSP packages

This text provides a very brief insight into a complex technology. A more in-depth account of soldering WLCSP (Wafer Level Chip-Size Packages) can be found in application note *AN10439 "Wafer Level Chip Scale Package"* and in application note *AN10365 "Surface mount reflow soldering description"*.

Wave soldering is not suitable for this package.

All NXP WLCSP packages are lead-free.

### 18.2 Board mounting

Board mounting of a WLCSP requires several steps:

1. Solder paste printing on the PCB
2. Component placement with a pick and place machine
3. The reflow soldering itself

### 18.3 Reflow soldering

Key characteristics in reflow soldering are:

- Lead-free versus SnPb soldering; note that a lead-free reflow process usually leads to higher minimum peak temperatures (see [Figure 32](#)) than a PbSn process, thus reducing the process window

- Solder paste printing issues, such as smearing, release, and adjusting the process window for a mix of large and small components on one board
- Reflow temperature profile; this profile includes preheat, reflow (in which the board is heated to the peak temperature), and cooling down. It is imperative that the peak temperature is high enough for the solder to make reliable solder joints (a solder paste characteristic) while being low enough that the packages and/or boards are not damaged. The peak temperature of the package depends on package thickness and volume and is classified in accordance with [Table 24](#)

**Table 25. Lead-free process (from J-STD-020C)**

| Package thickness (mm) | Package reflow temperature (°C) |             |        |
|------------------------|---------------------------------|-------------|--------|
|                        | Volume (mm <sup>3</sup> )       |             |        |
|                        | < 350                           | 350 to 2000 | > 2000 |
| < 1.6                  | 260                             | 260         | 260    |
| 1.6 to 2.5             | 260                             | 250         | 245    |
| > 2.5                  | 250                             | 245         | 245    |

Moisture sensitivity precautions, as indicated on the packing, must be respected at all times.

Studies have shown that small packages reach higher temperatures during reflow soldering, see [Figure 32](#).

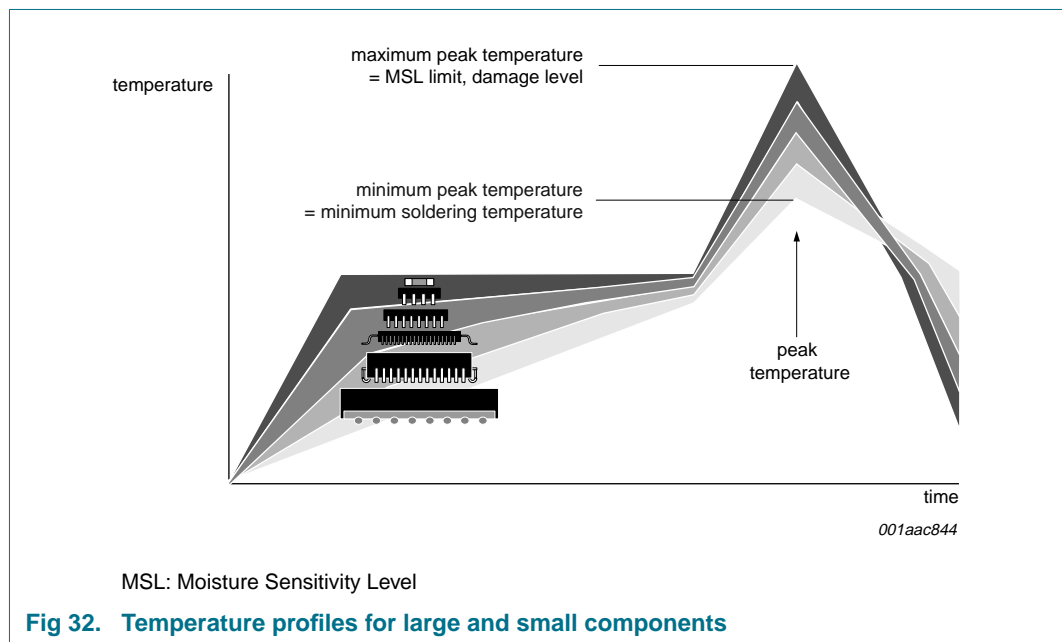

For further information on temperature profiles, refer to application note *AN10365 "Surface mount reflow soldering description"*.

### 18.3.1 Stand off

The stand off between the substrate and the chip is determined by:

- The amount of printed solder on the substrate
- The size of the solder land on the substrate

- The bump height on the chip

The higher the stand off, the better the stresses are released due to TEC (Thermal Expansion Coefficient) differences between substrate and chip.

### 18.3.2 Quality of solder joint

A flip-chip joint is considered to be a good joint when the entire solder land has been wetted by the solder from the bump. The surface of the joint should be smooth and the shape symmetrical. The soldered joints on a chip should be uniform. Voids in the bumps after reflow can occur during the reflow process in bumps with high ratio of bump diameter to bump height, i.e. low bumps with large diameter. No failures have been found to be related to these voids. Solder joint inspection after reflow can be done with X-ray to monitor defects such as bridging, open circuits and voids.

### 18.3.3 Rework

In general, rework is not recommended. By rework we mean the process of removing the chip from the substrate and replacing it with a new chip. If a chip is removed from the substrate, most solder balls of the chip will be damaged. In that case it is recommended not to re-use the chip again.

Device removal can be done when the substrate is heated until it is certain that all solder joints are molten. The chip can then be carefully removed from the substrate without damaging the tracks and solder lands on the substrate. Removing the device must be done using plastic tweezers, because metal tweezers can damage the silicon. The surface of the substrate should be carefully cleaned and all solder and flux residues and/or underfill removed. When a new chip is placed on the substrate, use the flux process instead of solder on the solder lands. Apply flux on the bumps at the chip side as well as on the solder pads on the substrate. Place and align the new chip while viewing with a microscope. To reflow the solder, use the solder profile shown in application note AN10365 "Surface mount reflow soldering description".

### 18.3.4 Cleaning

Cleaning can be done after reflow soldering.

## 19. Abbreviations

Table 26. Abbreviations

| Acronym | Description                             |
|---------|---|
| CMOS    | Complementary Metal Oxide Semiconductor |
| CDM     | Charged-Device Model                    |
| HBM     | Human Body Model                        |
| ITO     | Indium Tin Oxide                        |
| LCD     | Liquid Crystal Display                  |
| LSB     | Least Significant Bit                   |
| MM      | Machine Model                           |
| MSB     | Most Significant Bit                    |
| MSL     | Moisture Sensitivity Level              |
| PCB     | Printed Circuit Board                   |



Table 26. Abbreviations ...continued

| Acronym | Description                   |
|---------|-------------------------------|
| RAM     | Random Access Memory          |
| RMS     | Root Mean Square              |
| SMD     | Surface Mount Device          |
| WLCSP   | Wafer Level Chip-Size Package |

## 20. Revision history

**Table 27. Revision history**

| Document ID    | Release date                        | Data sheet status       | Change notice | Supersedes |
|----------------|-------------------------------------|-------------------------|---------------|------------|
| PCF8576D_7     | 20081218                            | Product data sheet      | -             | PCF8576D_6 |
| Modifications: | • Added tape and reel delivery form |                         |               |            |
| PCF8576D_6     | 20081202                            | Product data sheet      | -             | PCF8576D_5 |
| PCF8576D_5     | 20041222                            | Product specification   | -             | PCF8576D_4 |
| PCF8576D_4     | 20041008                            | Product specification   | -             | PCF8576D_3 |
| PCF8576D_3     | 20040617                            | Product specification   | -             | PCF8576D_2 |
| PCF8576D_2     | 20030623                            | Product specification   | -             | PCF8576D_1 |
| PCF8576D_1     | 20030401                            | Objective specification | -             | -          |

## 21. Legal information

### 21.1 Data sheet status

| Document status <sup>[1][2]</sup> | Product status <sup>[3]</sup> | Definition  |
|-----------------------------------|-------------------------------|---|
| Objective [short] data sheet      | Development                   | This document contains data from the objective specification for product development. |
| Preliminary [short] data sheet    | Qualification                 | This document contains data from the preliminary specification.                       |
| Product [short] data sheet        | Production                    | This document contains the product specification.                                     |

[1] Please consult the most recently issued document before initiating or completing a design.

[2] The term 'short data sheet' is explained in section "Definitions".

[3] The product status of device(s) described in this document may have changed since this document was published and may differ in case of multiple devices. The latest product status information is available on the Internet at URL <http://www.nxp.com>.

### 21.2 Definitions

**Draft** — The document is a draft version only. The content is still under internal review and subject to formal approval, which may result in modifications or additions. NXP Semiconductors does not give any representations or warranties as to the accuracy or completeness of information included herein and shall have no liability for the consequences of use of such information.

**Short data sheet** — A short data sheet is an extract from a full data sheet with the same product type number(s) and title. A short data sheet is intended for quick reference only and should not be relied upon to contain detailed and full information. For detailed and full information see the relevant full data sheet, which is available on request via the local NXP Semiconductors sales office. In case of any inconsistency or conflict with the short data sheet, the full data sheet shall prevail.

### 21.3 Disclaimers

**General** — Information in this document is believed to be accurate and reliable. However, NXP Semiconductors does not give any representations or warranties, expressed or implied, as to the accuracy or completeness of such information and shall have no liability for the consequences of use of such information.

**Right to make changes** — NXP Semiconductors reserves the right to make changes to information published in this document, including without limitation specifications and product descriptions, at any time and without notice. This document supersedes and replaces all information supplied prior to the publication hereof.

**Suitability for use** — NXP Semiconductors products are not designed, authorized or warranted to be suitable for use in medical, military, aircraft, space or life support equipment, nor in applications where failure or malfunction of an NXP Semiconductors product can reasonably be expected to result in personal injury, death or severe property or environmental damage. NXP Semiconductors accepts no liability for inclusion and/or use of NXP Semiconductors products in such equipment or applications and therefore such inclusion and/or use is at the customer's own risk.

**Applications** — Applications that are described herein for any of these products are for illustrative purposes only. NXP Semiconductors makes no representation or warranty that such applications will be suitable for the specified use without further testing or modification.

**Limiting values** — Stress above one or more limiting values (as defined in the Absolute Maximum Ratings System of IEC 60134) may cause permanent damage to the device. Limiting values are stress ratings only and operation of the device at these or any other conditions above those given in the Characteristics sections of this document is not implied. Exposure to limiting values for extended periods may affect device reliability.

**Terms and conditions of sale** — NXP Semiconductors products are sold subject to the general terms and conditions of commercial sale, as published at <http://www.nxp.com/profile/terms>, including those pertaining to warranty, intellectual property rights infringement and limitation of liability, unless explicitly otherwise agreed to in writing by NXP Semiconductors. In case of any inconsistency or conflict between information in this document and such terms and conditions, the latter will prevail.

**No offer to sell or license** — Nothing in this document may be interpreted or construed as an offer to sell products that is open for acceptance or the grant, conveyance or implication of any license under any copyrights, patents or other industrial or intellectual property rights.

**Bare die** — All die are tested on compliance with their related technical specifications as stated in this data sheet up to the point of wafer sawing and are handled in accordance with the NXP Semiconductors storage and transportation conditions. If there are data sheet limits not guaranteed, these will be separately indicated in the data sheet. There are no post-packing tests performed on individual die or wafers.

NXP Semiconductors has no control of third party procedures in the sawing, handling, packing or assembly of the die. Accordingly, NXP Semiconductors assumes no liability for device functionality or performance of the die or systems after third party sawing, handling, packing or assembly of the die. It is the responsibility of the customer to test and qualify their application in which the die is used.

All die sales are conditioned upon and subject to the customer entering into a written die sale agreement with NXP Semiconductors through its legal department.

### 21.4 Trademarks

Notice: All referenced brands, product names, service names and trademarks are the property of their respective owners.

**I<sup>2</sup>C-bus** — logo is a trademark of NXP B.V.

## 22. Contact information

For more information, please visit: <http://www.nxp.com>

For sales office addresses, please send an email to: [salesaddresses@nxp.com](mailto:salesaddresses@nxp.com)

23. Contents

|           |   |           |           |  |           |
|-----------|---|-----------|-----------|--|-----------|
| <b>1</b>  | <b>General description</b> . . . . .                  | <b>1</b>  | <b>13</b> | <b>Package outline</b> . . . . .                   | <b>36</b> |
| <b>2</b>  | <b>Features</b> . . . . .                             | <b>1</b>  | <b>14</b> | <b>Bare die outline</b> . . . . .                  | <b>38</b> |
| <b>3</b>  | <b>Ordering information</b> . . . . .                 | <b>2</b>  | <b>15</b> | <b>Handling information</b> . . . . .              | <b>41</b> |
| <b>4</b>  | <b>Marking</b> . . . . .                              | <b>2</b>  | <b>16</b> | <b>Packing information</b> . . . . .               | <b>42</b> |
| <b>5</b>  | <b>Block diagram</b> . . . . .                        | <b>3</b>  | 16.1      | Tray information . . . . .                         | 42        |
| <b>6</b>  | <b>Pinning information</b> . . . . .                  | <b>4</b>  | 16.2      | Carrier tape information . . . . .                 | 43        |
| 6.1       | Pinning . . . . .                                     | 4         | <b>17</b> | <b>Soldering of SMD packages</b> . . . . .         | <b>44</b> |
| 6.2       | Pin description . . . . .                             | 7         | 17.1      | Introduction to soldering . . . . .                | 44        |
| <b>7</b>  | <b>Functional description</b> . . . . .               | <b>7</b>  | 17.2      | Wave and reflow soldering . . . . .                | 44        |
| 7.1       | Power-on reset . . . . .                              | 8         | 17.3      | Wave soldering . . . . .                           | 44        |
| 7.2       | LCD bias generator . . . . .                          | 8         | 17.4      | Reflow soldering . . . . .                         | 45        |
| 7.3       | LCD voltage selector . . . . .                        | 9         | <b>18</b> | <b>Soldering of WLCSP packages</b> . . . . .       | <b>46</b> |
| 7.4       | LCD drive mode waveforms . . . . .                    | 11        | 18.1      | Introduction to soldering WLCSP packages . . . . . | 46        |
| 7.4.1     | Static drive mode . . . . .                           | 11        | 18.2      | Board mounting . . . . .                           | 46        |
| 7.4.2     | 1:2 Multiplex drive mode . . . . .                    | 12        | 18.3      | Reflow soldering . . . . .                         | 46        |
| 7.4.3     | 1:3 Multiplex drive mode . . . . .                    | 14        | 18.3.1    | Stand off . . . . .                                | 47        |
| 7.4.4     | 1:4 Multiplex drive mode . . . . .                    | 15        | 18.3.2    | Quality of solder joint . . . . .                  | 48        |
| 7.5       | Oscillator . . . . .                                  | 16        | 18.3.3    | Rework . . . . .                                   | 48        |
| 7.5.1     | Internal clock . . . . .                              | 16        | 18.3.4    | Cleaning . . . . .                                 | 48        |
| 7.5.2     | External clock . . . . .                              | 16        | <b>19</b> | <b>Abbreviations</b> . . . . .                     | <b>48</b> |
| 7.6       | Timing . . . . .                                      | 16        | <b>20</b> | <b>Revision history</b> . . . . .                  | <b>50</b> |
| 7.7       | Display register . . . . .                            | 16        | <b>21</b> | <b>Legal information</b> . . . . .                 | <b>51</b> |
| 7.8       | Segment outputs . . . . .                             | 16        | 21.1      | Data sheet status . . . . .                        | 51        |
| 7.9       | Backplane outputs . . . . .                           | 16        | 21.2      | Definitions . . . . .                              | 51        |
| 7.10      | Display RAM . . . . .                                 | 17        | 21.3      | Disclaimers . . . . .                              | 51        |
| 7.11      | Data pointer . . . . .                                | 18        | 21.4      | Trademarks . . . . .                               | 51        |
| 7.12      | Output bank selector . . . . .                        | 20        | <b>22</b> | <b>Contact information</b> . . . . .               | <b>51</b> |
| 7.13      | Input bank selector . . . . .                         | 20        | <b>23</b> | <b>Contents</b> . . . . .                          | <b>52</b> |
| 7.14      | Subaddress counter . . . . .                          | 20        |           |  |           |
| 7.15      | Blinker . . . . .                                     | 21        |           |  |           |
| 7.16      | Characteristics of the I <sup>2</sup> C-bus . . . . . | 22        |           |  |           |
| 7.16.1    | Bit transfer . . . . .                                | 22        |           |  |           |
| 7.16.2    | START and STOP conditions . . . . .                   | 22        |           |  |           |
| 7.16.3    | System configuration . . . . .                        | 22        |           |  |           |
| 7.16.4    | Acknowledge . . . . .                                 | 23        |           |  |           |
| 7.16.5    | I <sup>2</sup> C-bus controller . . . . .             | 23        |           |  |           |
| 7.16.6    | Input filters . . . . .                               | 24        |           |  |           |
| 7.16.7    | I <sup>2</sup> C-bus protocol . . . . .               | 24        |           |  |           |
| 7.17      | Command decoder . . . . .                             | 25        |           |  |           |
| 7.18      | Display controller . . . . .                          | 27        |           |  |           |
| <b>8</b>  | <b>Internal circuitry</b> . . . . .                   | <b>28</b> |           |  |           |
| <b>9</b>  | <b>Limiting values</b> . . . . .                      | <b>29</b> |           |  |           |
| <b>10</b> | <b>Static characteristics</b> . . . . .               | <b>29</b> |           |  |           |
| <b>11</b> | <b>Dynamic characteristics</b> . . . . .              | <b>31</b> |           |  |           |
| <b>12</b> | <b>Application information</b> . . . . .              | <b>33</b> |           |  |           |
| 12.1      | Cascaded operation . . . . .                          | 33        |           |  |           |

Please be aware that important notices concerning this document and the product(s) described herein, have been included in section 'Legal information'.

