

## High Side Line Switch with Low Supply Current

## GENERAL DESCRIPTION

The XC8101 series is a low supply current line switch IC with ON/OFF control and output current protection which integrates P-channel MOSFET. The XC8101 is suited for power distribution switch. With connecting to the output pin of step-down DC/DC converters, the CE pin controls ON/OFF for each distribution switch to deliver power per requirements and maximize total power efficiency. As result, the XC8101 helps extend battery life and product operation time. The XC8101 is available in an ultra small package USP-4 and does not require any external capacitors so that it can provide small power unit design and board space saving. When low signal is input to the CE pin, the XC8101 enters stand-by mode. Even where a load capacitor is connected to the output pin during in the stand-by mode, the internal switch between the  $V_{OUT}$  and  $V_{SS}$  of the XC8101 enables the electric charge in the load capacitor to be discharged. Because of this discharge function, the  $V_{OUT}$  pin voltage falls quickly to  $V_{SS}$  level.

The XC8101 contains an over current protection with foldback current circuitry which operates as over current protection and short circuit protection for the output pin.

## APPLICATIONS

- Mobile phones, Smart phones
- Digital still cameras, Digital video cameras
- Portable games
- Portable equipment

## FEATURES

- On Resistance :  $0.75\Omega @ V_{IN}=2.9V$  (TYP.)
- Output Current :  $1.15\Omega @ V_{IN}=1.8V$  (TYP.)
- Output Current : 200mA
- Output Current : <Current Limit =300mA (TYP.)>
- Input Voltage Range : 1.8V ~ 6.0V
- Power Consumption :  $3.0\mu A @ V_{IN}=1.8V$
- Stand-by Current :  $0.1\mu A$
- Protection Circuit : Current limit, 300mA (TYP.)
- Protection Circuit : Short-circuit Protection, Short current= 30mA (TYP.)
- ON/OFF Function : High Active Enable
- High-Speed Discharge Function
- Operating Temperature Range : -40 ~ 85
- Packages : USP-4, SSOT-24, SOT-25

## TYPICAL APPLICATION CIRCUIT

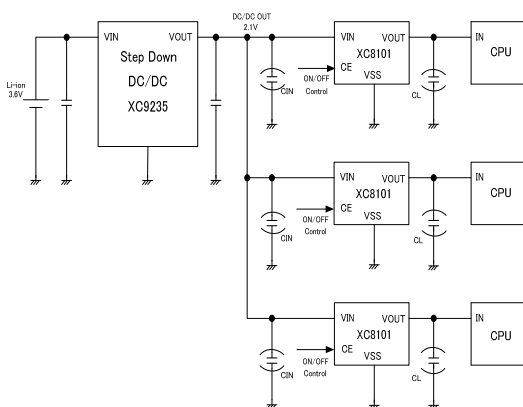

## TYPICAL PERFORMANCE CHARACTERISTICS

## Supply Current vs. Input Voltage

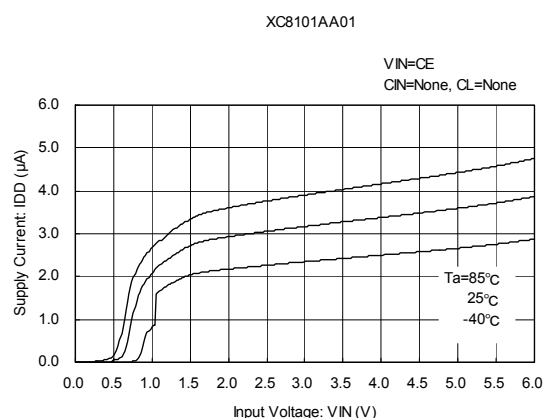

## PIN CONFIGURATION

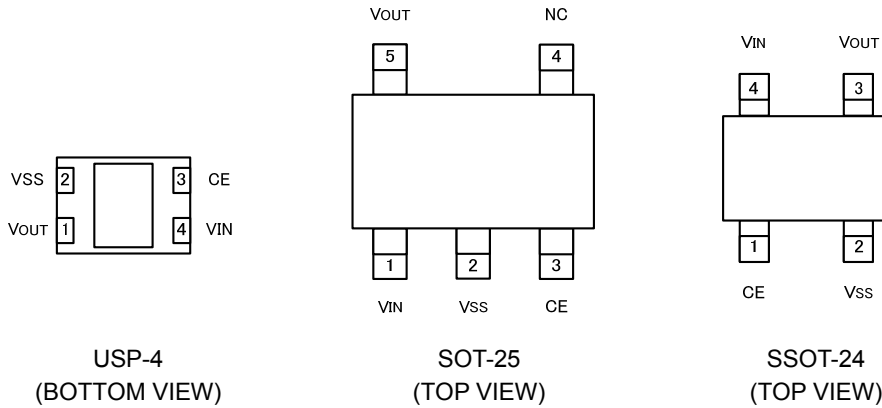

\*The heat dissipation pad of the USP-4 package is recommended to solder as shown in the recommended mount pattern and metal mask pattern for mounting strength. The heat dissipation pad should be electrically opened or connected to the V<sub>SS</sub> (No. 2) pin.

## PIN ASSIGNMENT

| PIN NUMBER |        |         | PIN NAME         | FUNCTIONS      |
|------------|--------|---------|------------------|----------------|
| USP-4      | SOT-25 | SSOT-24 |                  |                |
| 4          | 1      | 4       | V <sub>IN</sub>  | Power Input    |
| 1          | 5      | 3       | V <sub>OUT</sub> | Output         |
| 2          | 2      | 2       | V <sub>SS</sub>  | Ground         |
| 3          | 3      | 1       | CE               | ON/OFF Control |
| -          | 4      | -       | NC               | No Connection  |

## PRODUCT CLASSIFICATION

Ordering Information

XC8101 \_\_\_\_\_

| DESIGNATOR | DESCRIPTION                       | SYMBOL | DESCRIPTION                                                             |
|------------|-----------------------------------|--------|-------------------------------------------------------------------------|
|            | CE pin logic                      | A      | : High active enable                                                    |
|            | C <sub>L</sub> Discharge Function | A      | : Output capacitor (C <sub>L</sub> ) auto-discharge function integrated |
|            | Internal Standard Number          | 01     | : Fixed                                                                 |
|            | Packages                          | G      | : USP-4                                                                 |
|            |                                   | M      | : SOT-25                                                                |
|            |                                   | N      | : SSOT-24                                                               |
|            | Device Orientation                | R      | : Embossed tape, standard feed                                          |
|            |                                   | L      | : Embossed tape, reverse feed                                           |

## FUNCTION CHART

| SERIES     | CE   | IC OPERATIONAL STATUS<br>ON/OFF |
|------------|------|---------------------------------|
| XC8101AA01 | High | ON                              |
|            | Low  | OFF                             |

## BLOCK DIAGRAM

XC8101AA Series

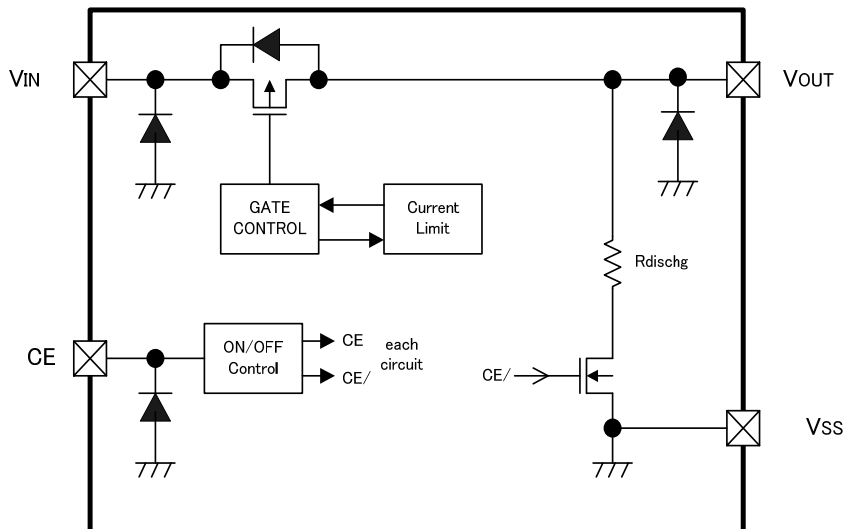

\* Diodes inside the circuit are an ESD protection diode and a parasitic diode.

## ABSOLUTE MAXIMUM RATINGS

Ta=25

| PARAMETER                   |         | SYMBOL           | RATINGS                                | UNITS |
|-----------------------------|---------|------------------|----------------------------------------|-------|
| Input Voltage               |         | V <sub>IN</sub>  | V <sub>SS</sub> -0.3 ~ +6.5            | V     |
| Output Current              |         | I <sub>OUT</sub> | 450 *                                  | mA    |
| Output Voltage              |         | V <sub>OUT</sub> | V <sub>SS</sub> -0.3 ~ V <sub>IN</sub> | V     |
| CE Input Voltage            |         | V <sub>CE</sub>  | V <sub>SS</sub> -0.3 ~ +6.5            | V     |
| Power Dissipation           | USP-4   | Pd               | 120                                    | mW    |
|                             | SOT-25  |                  | 150                                    |       |
|                             | SSOT-24 |                  | 250                                    |       |
| Operating Temperature Range |         | Topr             | -40 ~ +85                              | °C    |
| Storage Temperature Range   |         | Tstg             | -55 ~ +125                             | °C    |

\* Please make sure that I<sub>OUT</sub> is less than Pd/(V<sub>IN</sub>-V<sub>OUT</sub>).

## ELECTRICAL CHARACTERISTICS

XC8101AA Series

Ta=25

| PARAMETER                                | SYMBOL                | CONDITIONS                                                                                                        | MIN. | TYP. | MAX. | UNITS | CIRCUIT |
|------------------------------------------|-----------------------|-------------------------------------------------------------------------------------------------------------------|------|------|------|-------|---------|
| Input Voltage                            | V <sub>IN</sub>       |                                                                                                                   | 1.8  | -    | 6.0  | V     | -       |
| On Resistance<br>(SSOT-24 / USP-4)       | R <sub>ON</sub>       | V <sub>IN</sub> =6.0V, V <sub>CE</sub> =V <sub>IN</sub>                                                           | -    | 0.55 | 0.90 |       |         |
|                                          |                       | V <sub>IN</sub> =4.0V, V <sub>CE</sub> =V <sub>IN</sub>                                                           | -    | 0.65 | 1.00 |       |         |
|                                          |                       | V <sub>IN</sub> =2.9V, V <sub>CE</sub> =V <sub>IN</sub>                                                           | -    | 0.75 | 1.10 |       |         |
|                                          |                       | V <sub>IN</sub> =1.8V, V <sub>CE</sub> =V <sub>IN</sub>                                                           | -    | 1.15 | 1.50 |       |         |
| On Resistance<br>(SOT-25)                | R <sub>ON</sub>       | V <sub>IN</sub> =6.0V, V <sub>CE</sub> =V <sub>IN</sub>                                                           | -    | 0.65 | 1.00 |       |         |
|                                          |                       | V <sub>IN</sub> =4.0V, V <sub>CE</sub> =V <sub>IN</sub>                                                           | -    | 0.75 | 1.10 |       |         |
|                                          |                       | V <sub>IN</sub> =2.9V, V <sub>CE</sub> =V <sub>IN</sub>                                                           | -    | 0.85 | 1.20 |       |         |
|                                          |                       | V <sub>IN</sub> =1.8V, V <sub>CE</sub> =V <sub>IN</sub>                                                           | -    | 1.25 | 1.60 |       |         |
| Supply Current                           | I <sub>DD</sub>       | V <sub>IN</sub> =6.0V, V <sub>CE</sub> =V <sub>IN</sub> , V <sub>OUT</sub> =OPEN                                  | -    | 2.7  | 8.2  | μA    |         |
|                                          |                       | V <sub>IN</sub> =4.0V, V <sub>CE</sub> =V <sub>IN</sub> , V <sub>OUT</sub> =OPEN                                  | -    | 2.3  | 7.3  |       |         |
|                                          |                       | V <sub>IN</sub> =2.9V, V <sub>CE</sub> =V <sub>IN</sub> , V <sub>OUT</sub> =OPEN                                  | -    | 2.2  | 6.9  |       |         |
|                                          |                       | V <sub>IN</sub> =1.8V, V <sub>CE</sub> =V <sub>IN</sub> , V <sub>OUT</sub> =OPEN                                  | -    | 2.0  | 6.2  |       |         |
| Stand-by Current                         | I <sub>STBY</sub>     | V <sub>IN</sub> =6.0V, V <sub>CE</sub> =V <sub>SS</sub> , V <sub>OUT</sub> =OPEN                                  | -    | 0.01 | 0.10 | μA    |         |
| Switch Leakage Current                   | I <sub>LEAK</sub>     | V <sub>IN</sub> =6.0V, V <sub>CE</sub> =V <sub>OUT</sub> =V <sub>SS</sub>                                         | -    | 0.01 | 0.10 | μA    |         |
| Current Limit                            | I <sub>LIM</sub>      | V <sub>CE</sub> =V <sub>IN</sub> , V <sub>OUT</sub> =V <sub>IN</sub> - 1.0V                                       | 200  | 300  | -    | mA    |         |
| Short Circuit Current                    | I <sub>SHORT</sub>    | V <sub>CE</sub> =V <sub>IN</sub> , V <sub>OUT</sub> =0V                                                           | -    | 30   | -    | mA    |         |
| CE High Level Voltage                    | V <sub>CEH</sub>      |                                                                                                                   | 1.2  | -    | 6.0  | V     |         |
| CE Low Level Voltage                     | V <sub>CEL</sub>      |                                                                                                                   | -    | -    | 0.3  | V     |         |
| CE High Level Current                    | I <sub>CEH</sub>      | V <sub>CE</sub> =V <sub>IN</sub>                                                                                  | -0.1 | -    | 0.1  | μA    |         |
| CE Low Level Current                     | I <sub>CEL</sub>      | V <sub>CE</sub> =V <sub>SS</sub>                                                                                  | -0.1 | -    | 0.1  | μA    |         |
| C <sub>L</sub> Auto-Discharge Resistance | R <sub>DCHG</sub>     | V <sub>IN</sub> =4.0V, V <sub>OUT</sub> =4.0V, V <sub>CE</sub> =V <sub>SS</sub>                                   | 650  | 900  | 1100 |       |         |
| Turn On Time <sup>(1)</sup>              | t <sub>DLY(ON)</sub>  | V <sub>IN</sub> =4.0V, V <sub>CE</sub> =0.3V 1.2V, R <sub>L</sub> =80 Ω, without C <sub>IN</sub> , C <sub>L</sub> | -    | 6    | 13   | μs    |         |
| Turn Off Time <sup>(2)</sup>             | t <sub>DLY(OFF)</sub> | V <sub>IN</sub> =4.0V, V <sub>CE</sub> =1.2V 0.3V, R <sub>L</sub> =80 Ω, without C <sub>IN</sub> , C <sub>L</sub> | -    | 2.0  | 4.0  | μs    |         |

NOTE:

\*1: Time to reach 90% of V<sub>OUT</sub> after V<sub>CE</sub> entering the V<sub>CEH</sub> threshold.

\*2: Time to fall to 10% of V<sub>OUT</sub> after V<sub>CE</sub> entering the V<sub>CEL</sub> threshold.

## TEST CIRCUITS

Circuit

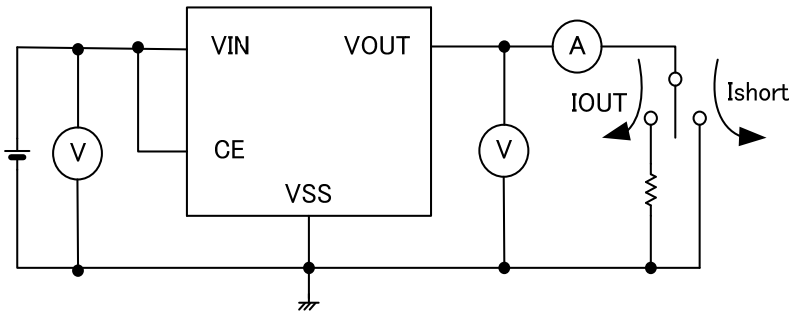

Circuit

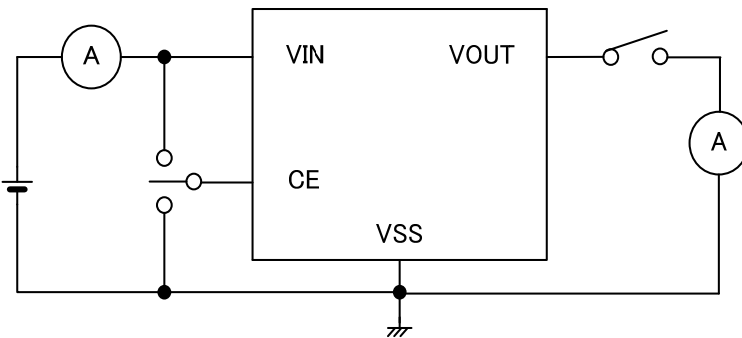

Circuit

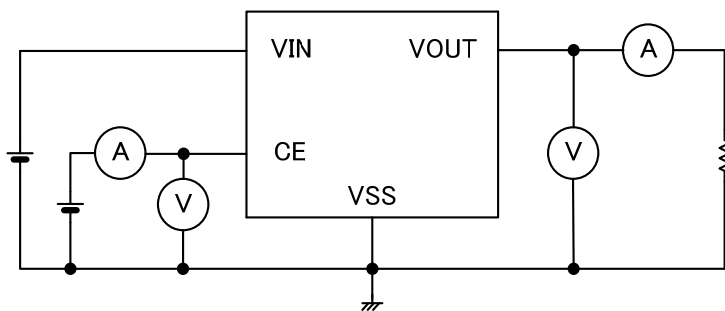

## TEST CIRCUITS (Continued)

Circuit

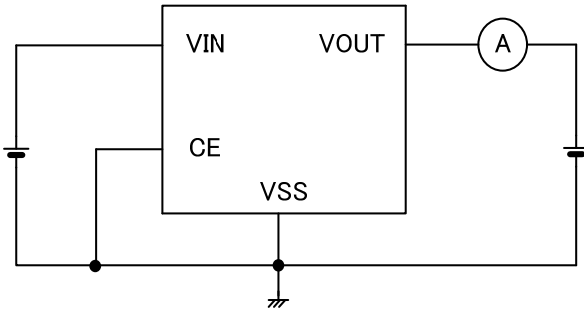

Circuit

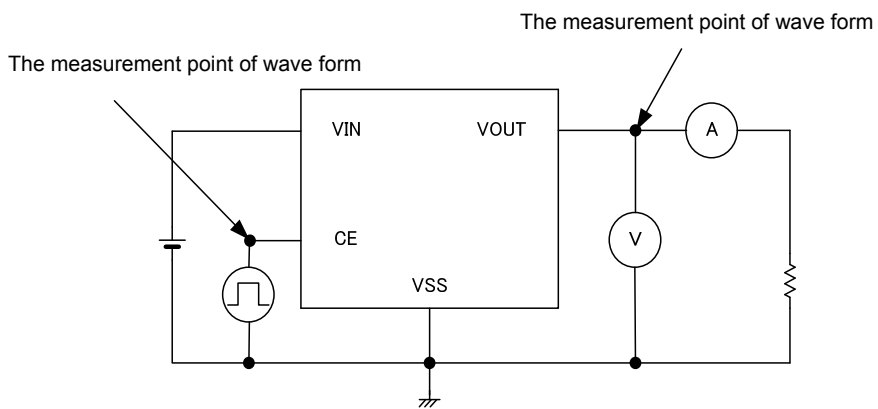

## OPERATIONAL EXPLANATION

### <CE Pin>

The XC8101 enables an output P-channel MOSFET switch and the IC internal circuitry to turn off by the signal to the CE pin. In the shutdown mode, the  $V_{OUT}$  pin will be pulled down to the  $V_{SS}$  by the  $C_L$  auto-discharge function.

The output voltage becomes unstable when the CE pin is opened. If the input voltage to the CE pin is within the specified threshold voltages, the logic is fixed and the XC8101 will operate normally. However, supply current may increase as a result of the shoot-through current of internal circuitry when the medium level voltage is input to the CE pin.

### <Input Capacitor>

The XC8101 works well without an output capacitor ( $C_L$ ). However, an output capacitor such as a bypass capacitor is tied up to the output side of the IC, input voltage ringing may occur when the IC is turned on. In order to reduce the ringing, an input capacitor with the value of  $1\ \mu\text{F}$  or more is requested to attach between  $V_{IN}$  pin and  $V_{SS}$  pin. The capacitor should be tied and placed as close as the IC.

### <CL Auto-Discharge Function>

The XC8101A contains a  $C_L$  auto-discharge resistor and an N-channel transistor between the  $V_{OUT}$  pin and the  $V_{SS}$  pin. The XC8101A quickly discharge the electric charge in the output capacitor ( $C_L$ ) when a low signal to the CE pin is input to turn off a whole IC circuit. The  $C_L$  auto-discharge resistance is set at  $900\ \Omega$  ( $V_{OUT}=4.0\text{V TYP. @ } V_{IN}=4.0$ ). Discharge time of the output capacitor ( $C_L$ ) is determined by a  $C_L$  auto-discharge resistor value ( $R_{DCHG}$ ) and an output capacitor value. Time constant  $\tau$  is defined as ( $\tau = C \times R_{DCHG}$ ). Output voltage after starting discharge can be calculated by the following formula.

$$V = V_{OUT} \times e^{-t/\tau}, \text{ or } t = \tau \ln(V_{OUT} / V)$$

V: Output voltage after starting discharge

$V_{OUT}$ : Output voltage

t: Discharge time

$\tau$ : Output discharge resistor value  $R_{dischg}$   $\times$  Output capacitor ( $C_L$ ) value C

### <Current Limiter, Short-Circuit Protection>

The XC8101 series contains a constant current limiter and foldback current circuitry. The constant current limiter operates to limit output current and the foldback current circuitry operates as short circuit protection for the output pin.

When the load current reaches the limit current, the constant current limiter operates and the output voltage drops. The output voltage further, then the foldback current circuitry operates to decrease the output current. When the output pin is short-circuited to the ground, the output current drops and maintains a flow about 30mA.

## NOTES ON USE

1. Please use this IC within the stated absolute maximum ratings. Operation beyond these limits may cause degrading or permanent damage to the device.
2. The X8101 goes into an undefined operation when the CE pin is left open. The CE pin shall be tied to low or high level.
3.  $V_{OUT}$  pin voltage should not be applied beyond the  $V_{IN}$  pin voltage. The IC may get damage due to the reverse current toward the  $V_{IN}$  pin.

## TYPICAL PERFORMANCE CHARACTERISTICS

### (1) ON Resistance vs. Input Voltage

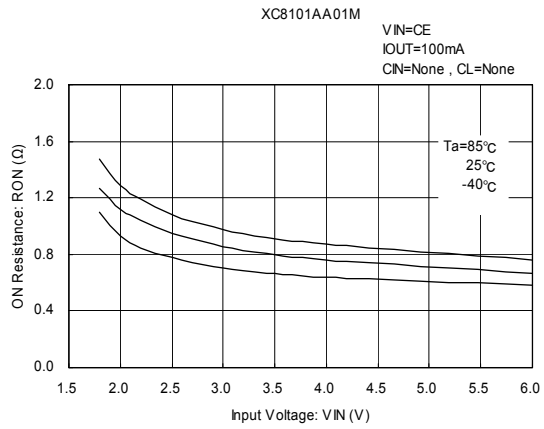
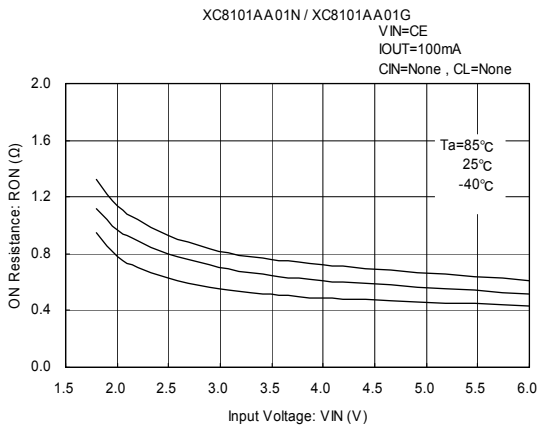

### (2) ON Resistance vs. Ambient Temperature

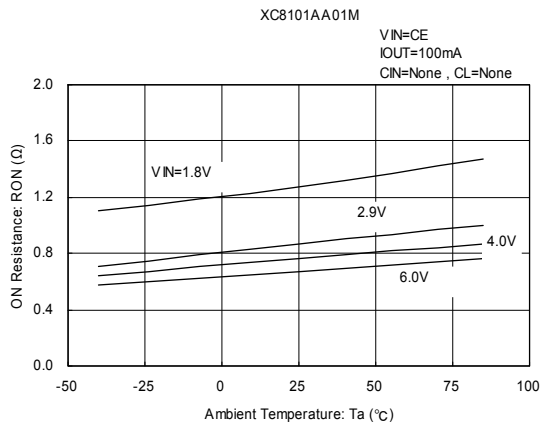
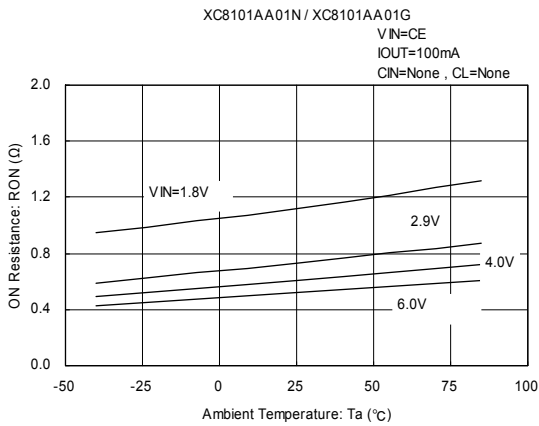

### (3) Supply Current vs. Input Voltage

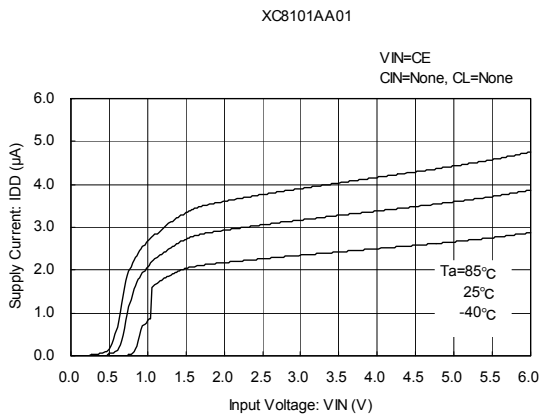

### (4) Supply Current vs. Ambient Temperature

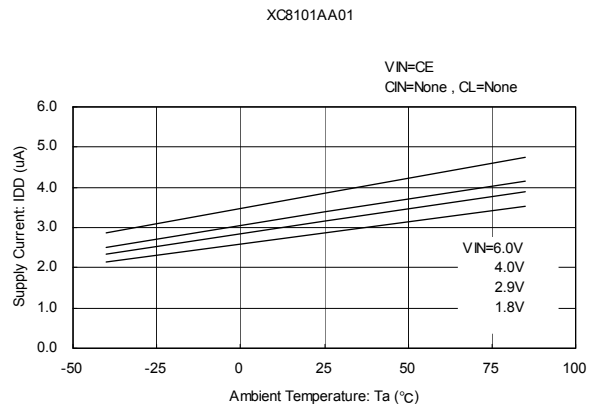



## TYPICAL PERFORMANCE CHARACTERISTICS (Continued)

### (5) Output Voltage vs. Output Current

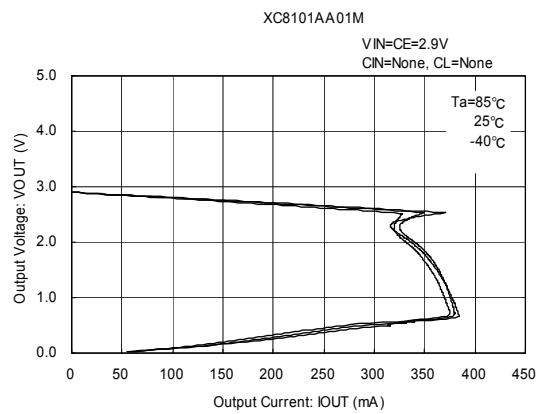
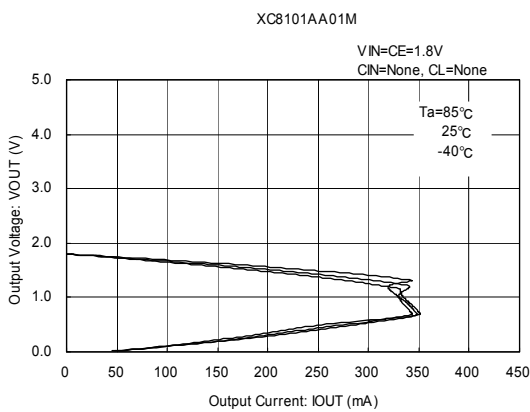
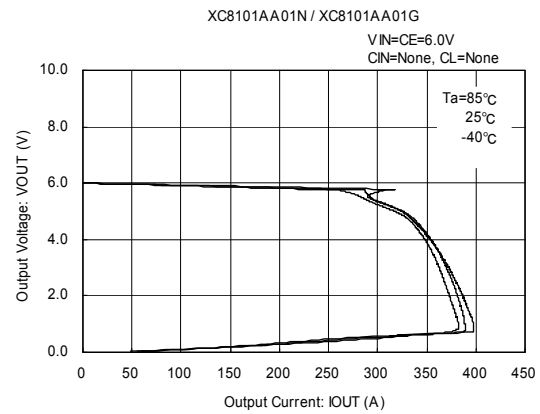
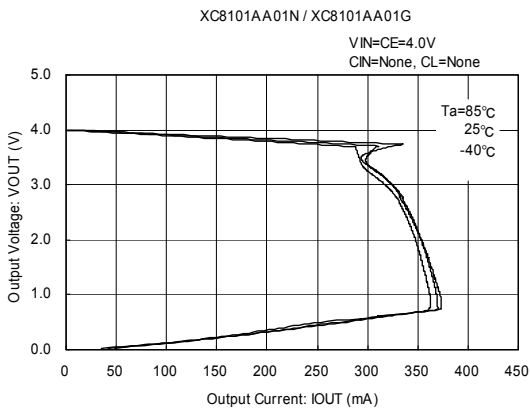
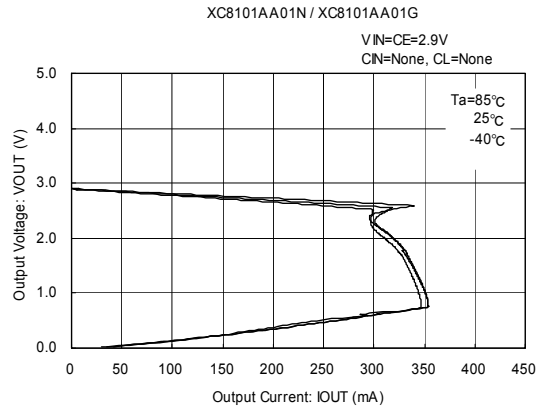
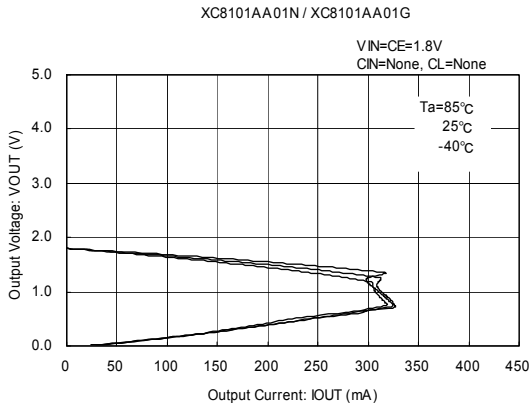

## TYPICAL PERFORMANCE CHARACTERISTICS (Continued)

### (5) Output Voltage vs. Output Current (Continued)

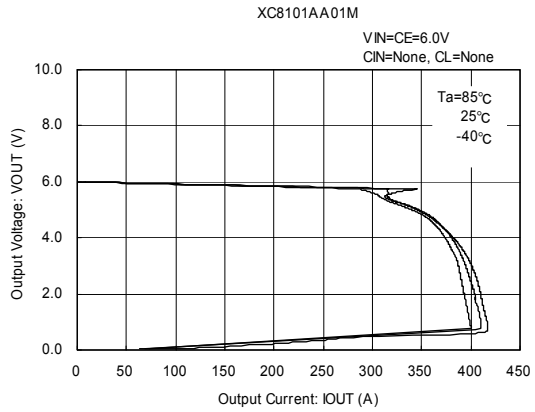
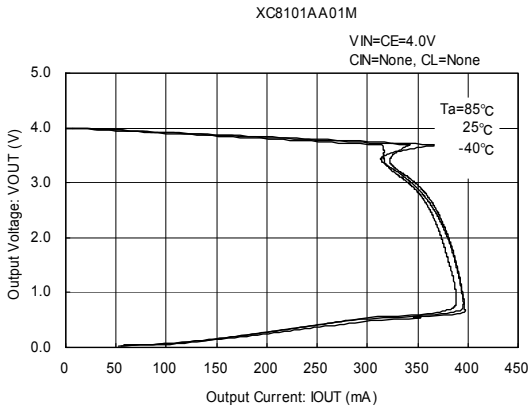

### (6) CE Threshold Voltage vs. Ambient Temperature

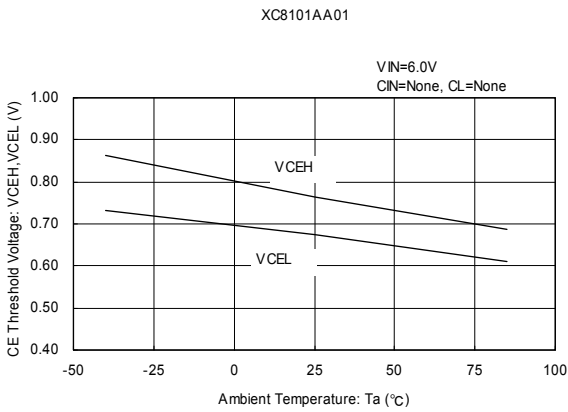

### (7) CL Discharge Resistance vs. Ambient Temperature

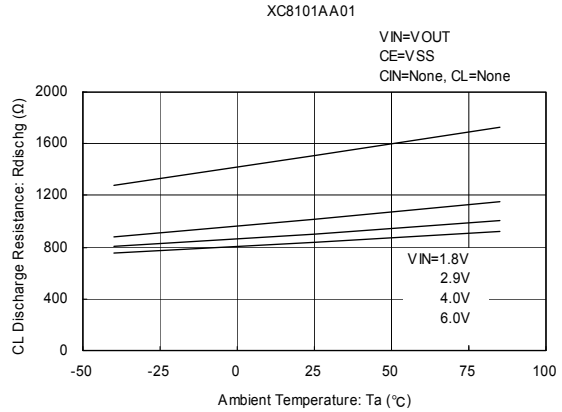

### (8) Output Turn-on Time with CE

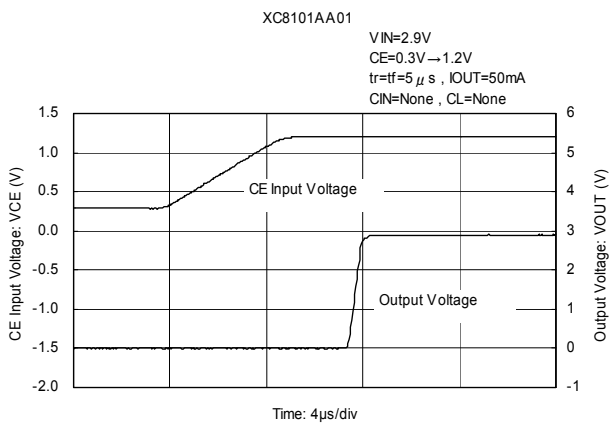
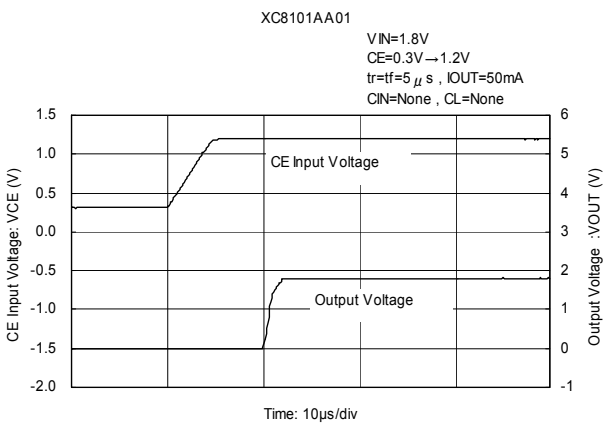

## TYPICAL PERFORMANCE CHARACTERISTICS (Continued)

### (8) Output Turn-on Time with CE (Continued)

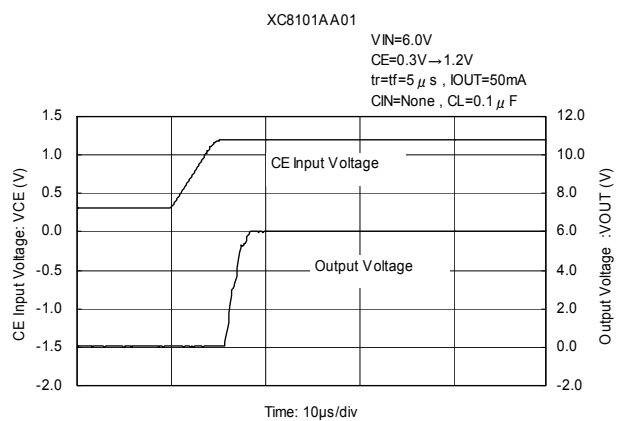
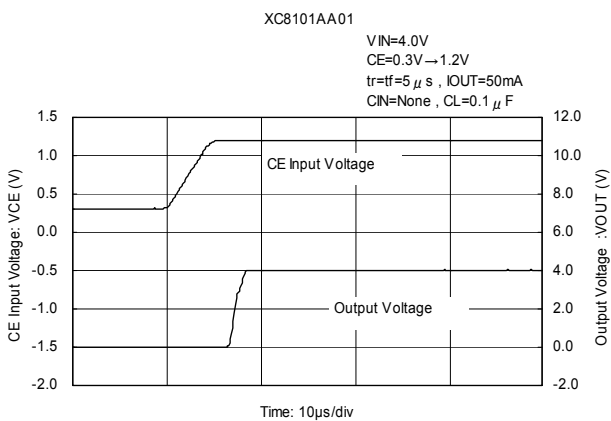
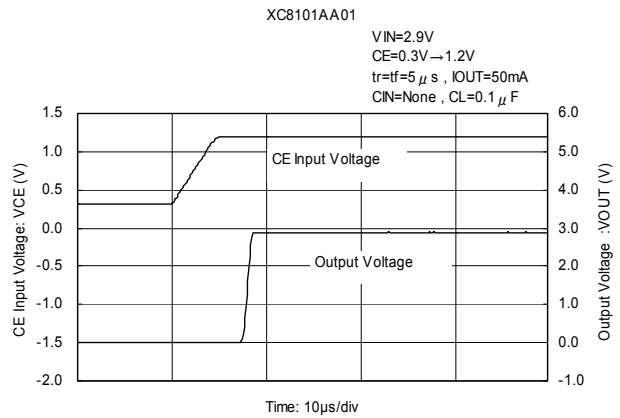
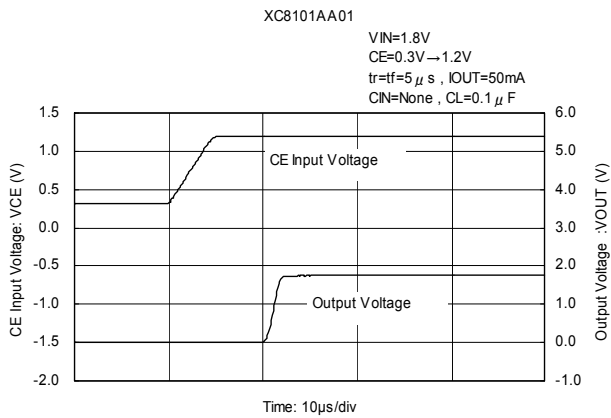
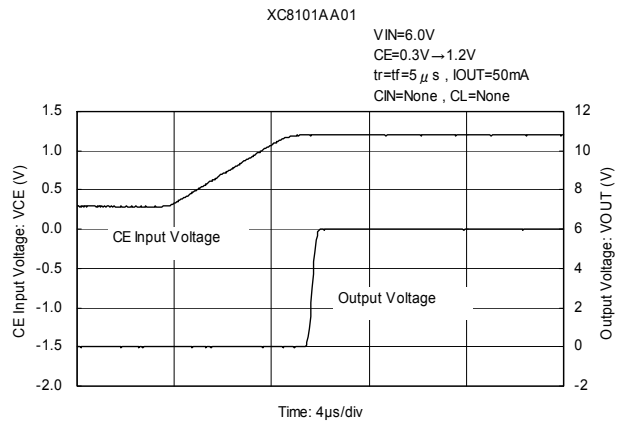
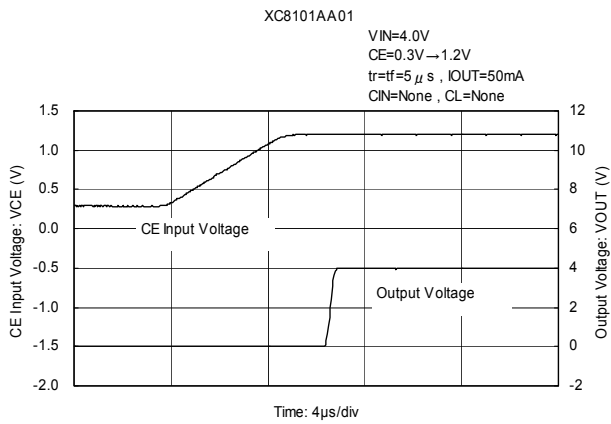

## TYPICAL PERFORMANCE CHARACTERISTICS (Continued)

### (8) Output Turn-on Time with CE (Continued)

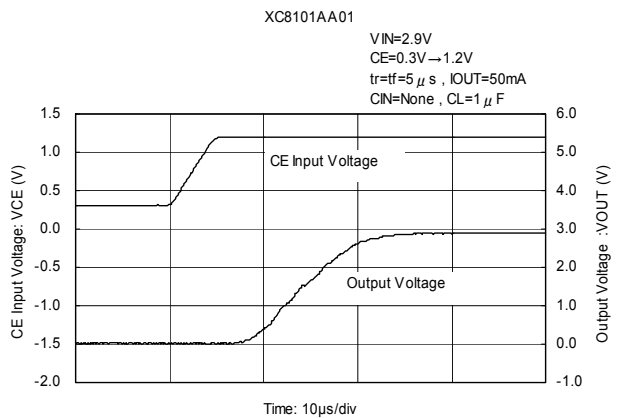
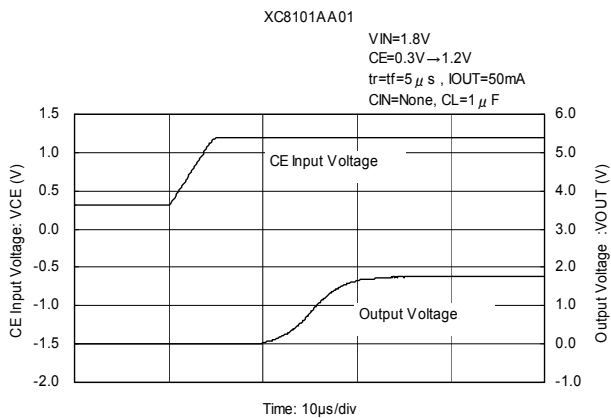
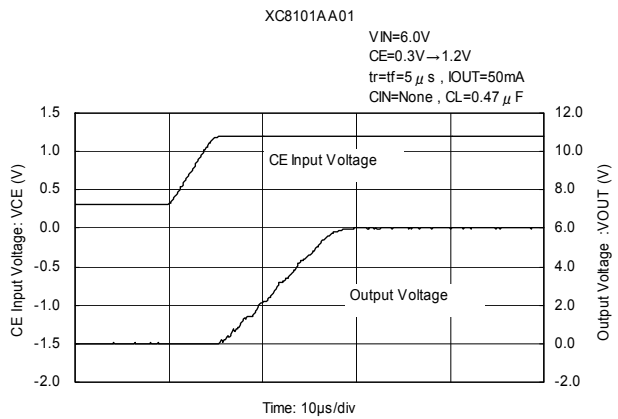
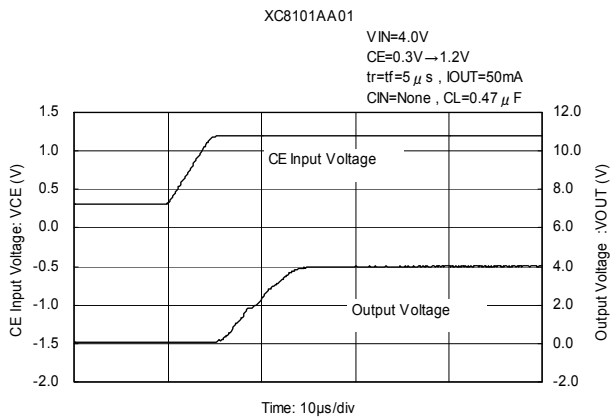
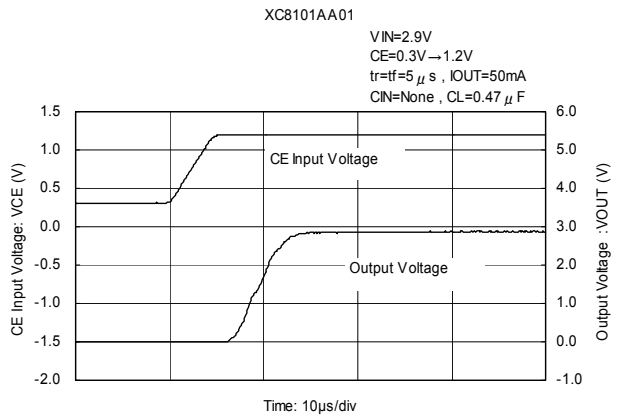
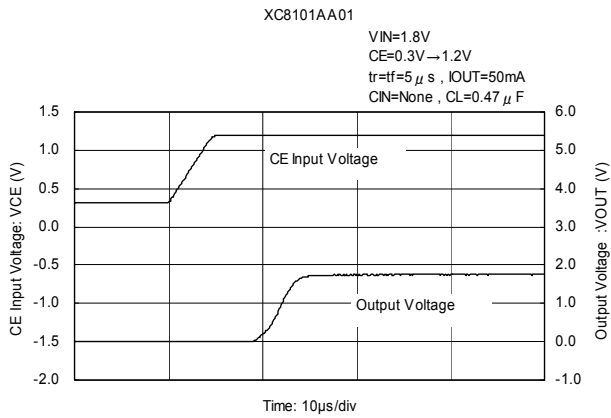

## TYPICAL PERFORMANCE CHARACTERISTICS (Continued)

### (8) Output Turn-on Time with CE (Continued)

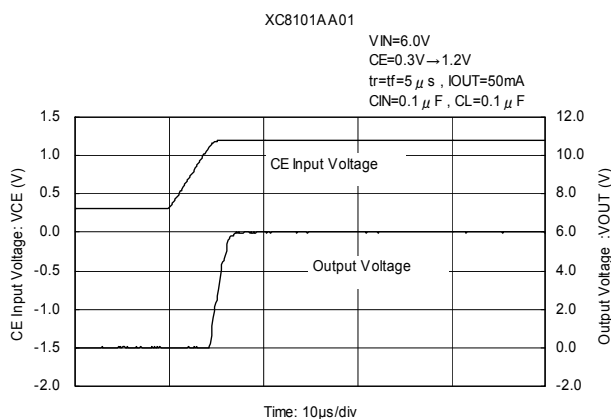
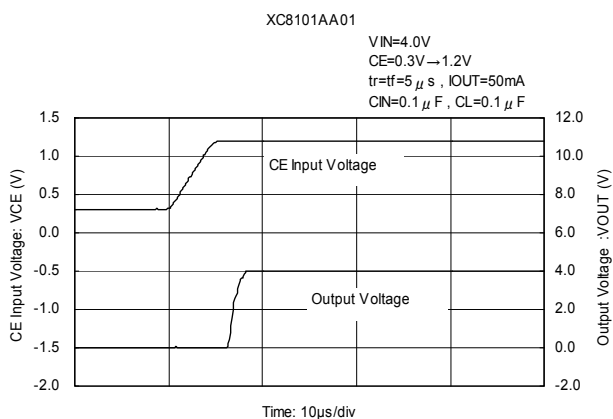
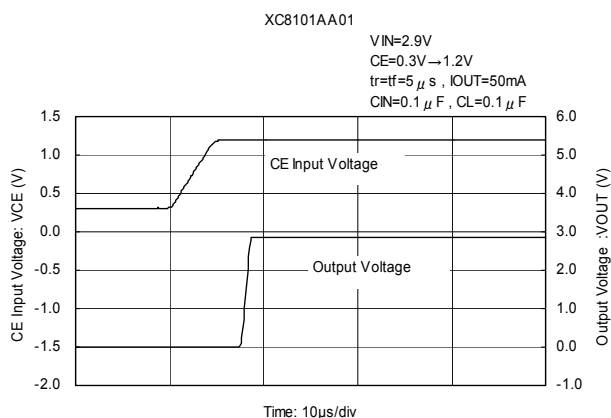
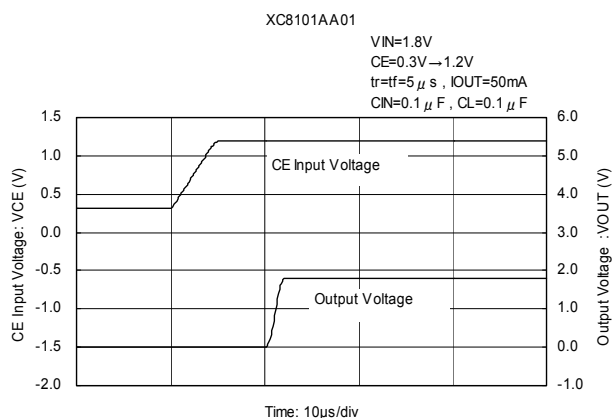
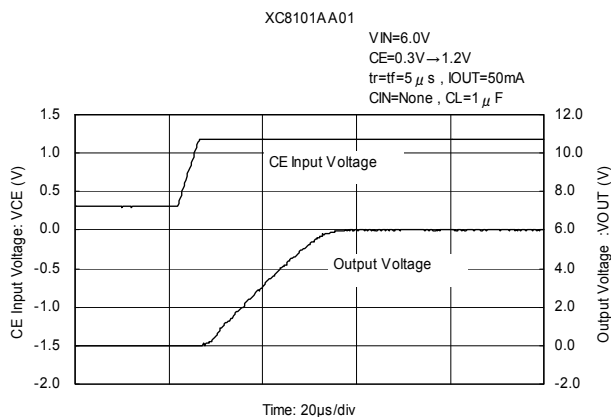
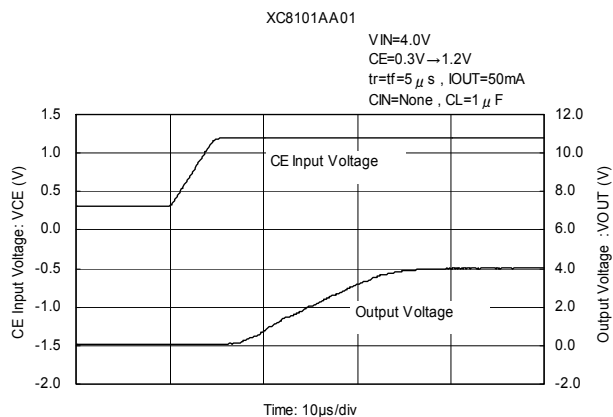

## TYPICAL PERFORMANCE CHARACTERISTICS (Continued)

### (8) Output Turn-on Time with CE (Continued)

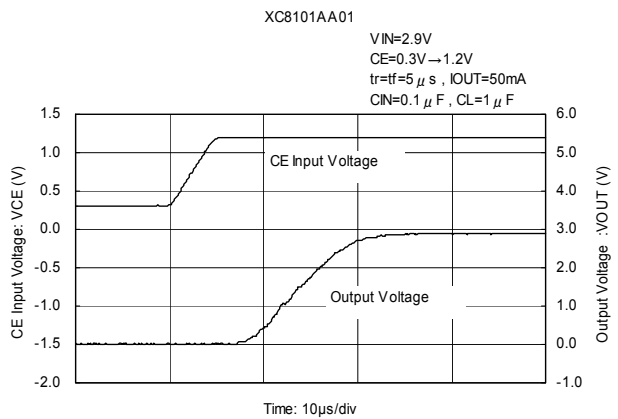
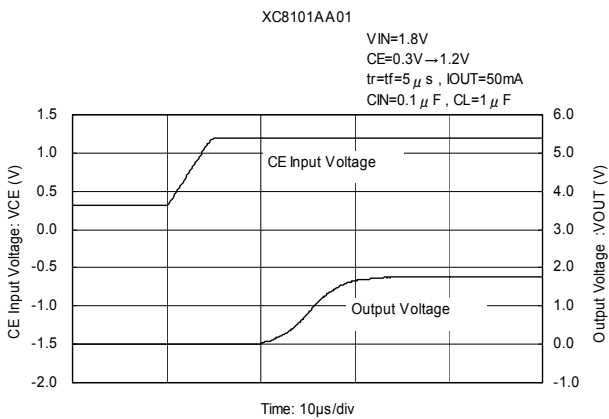
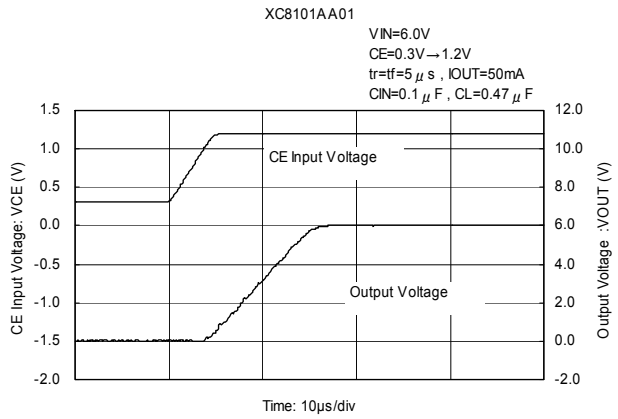
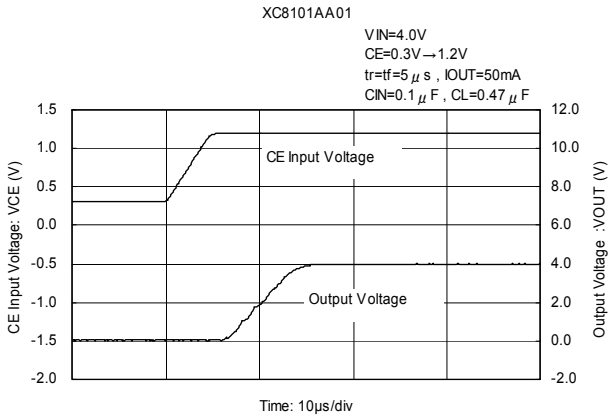
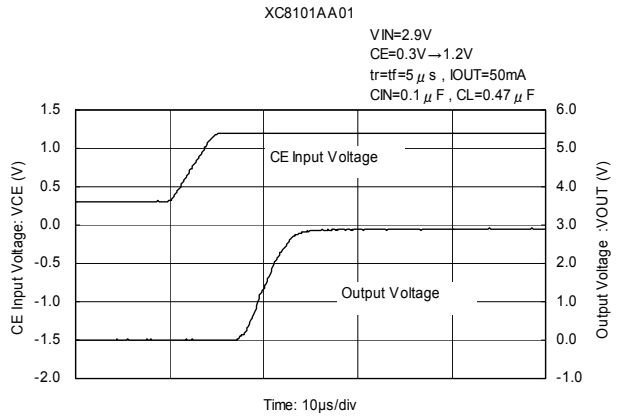
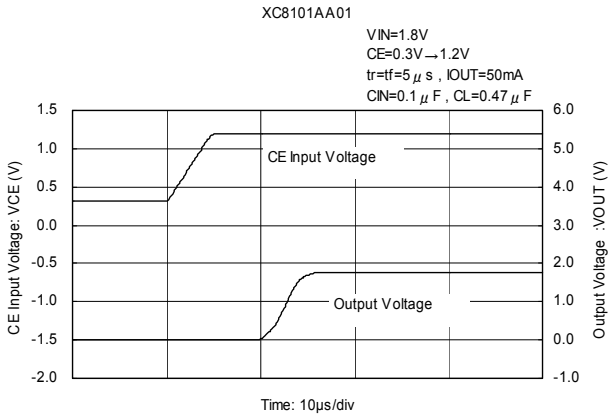

## TYPICAL PERFORMANCE CHARACTERISTICS (Continued)

### (8) Output Turn-on Time with CE (Continued)

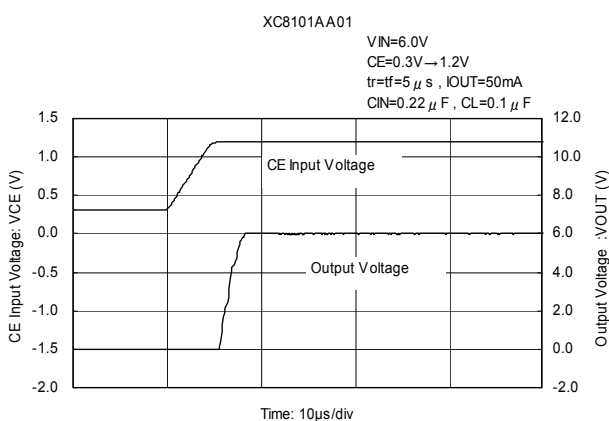
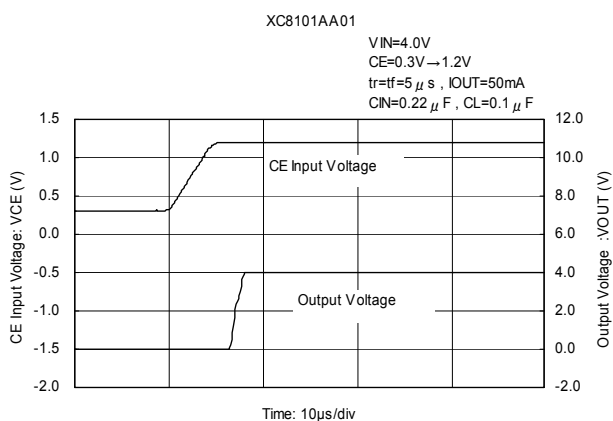
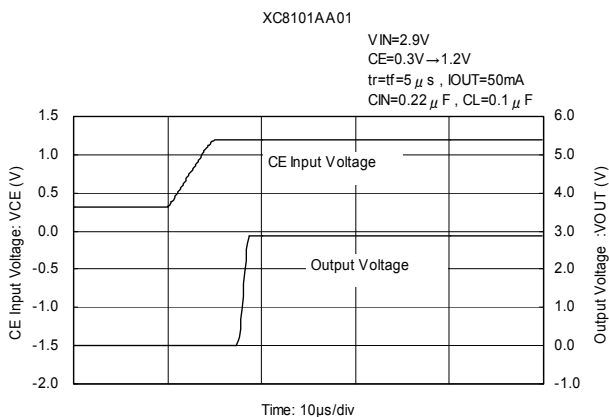
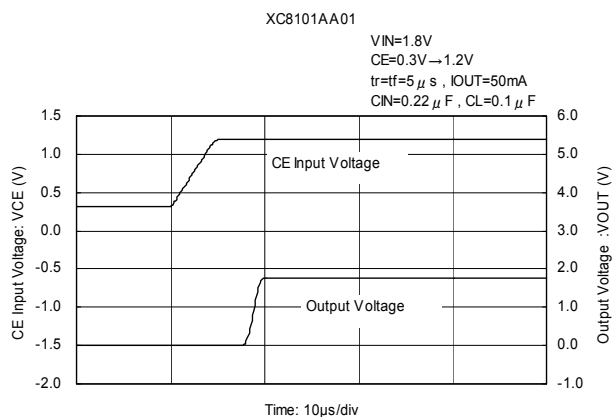
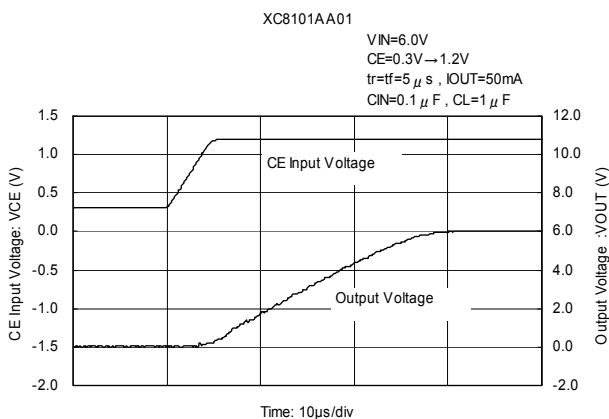
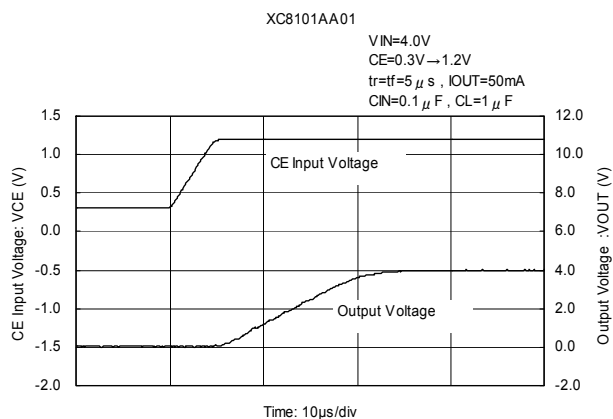

## TYPICAL PERFORMANCE CHARACTERISTICS (Continued)

### (8) Output Turn-on Time with CE (Continued)

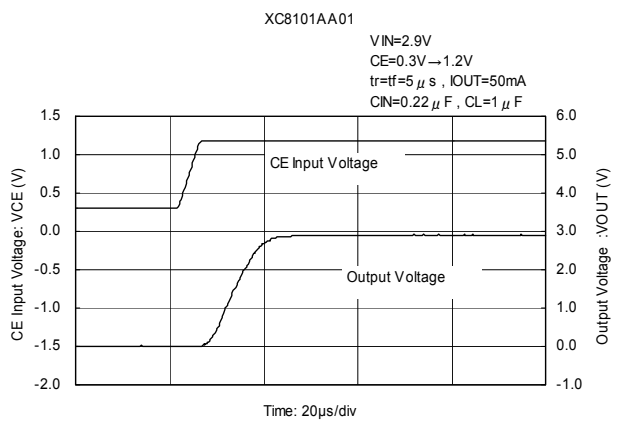
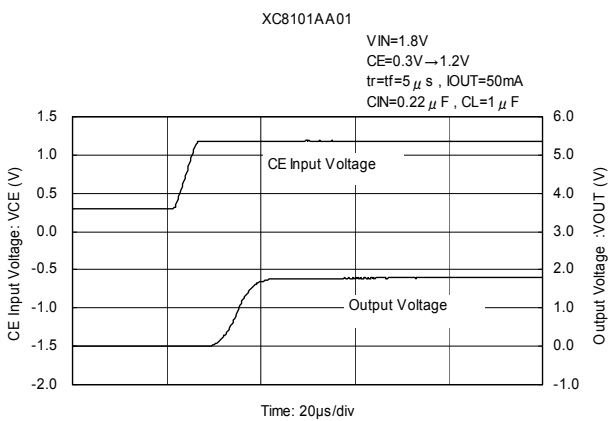
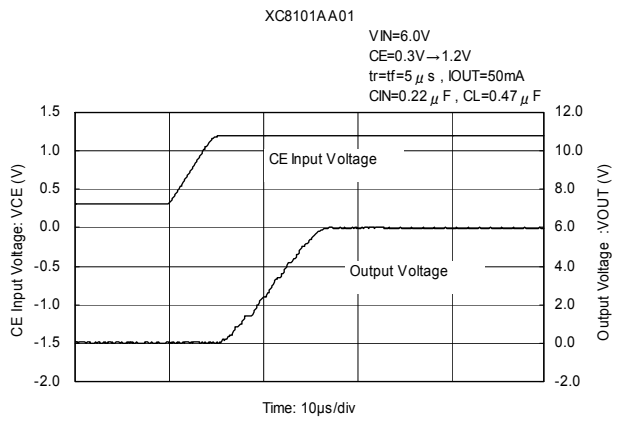
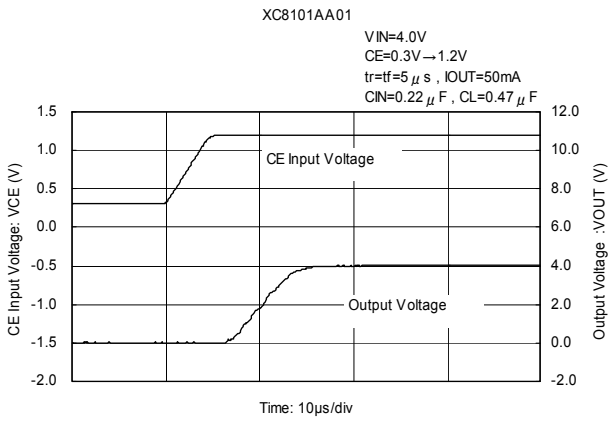
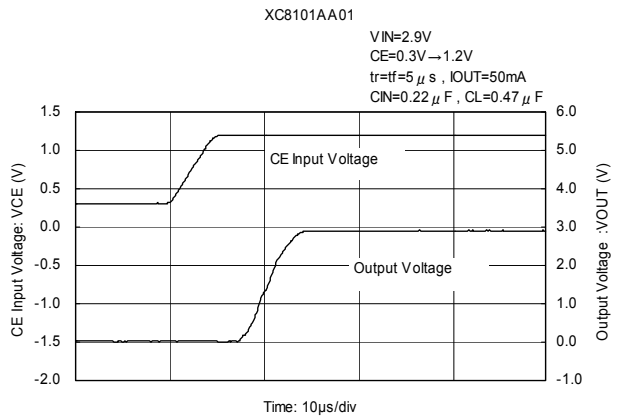
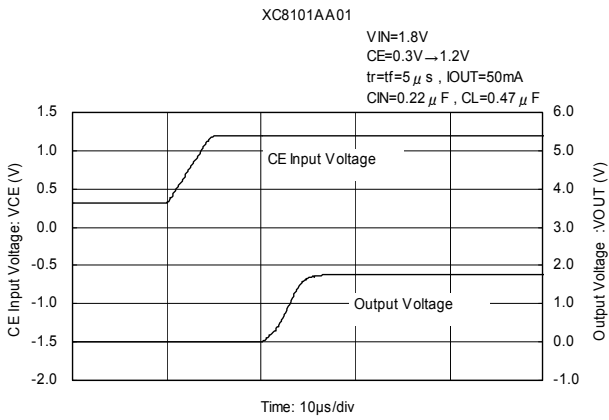



## TYPICAL PERFORMANCE CHARACTERISTICS (Continued)

### (8) Output Turn-on Time with CE (Continued)

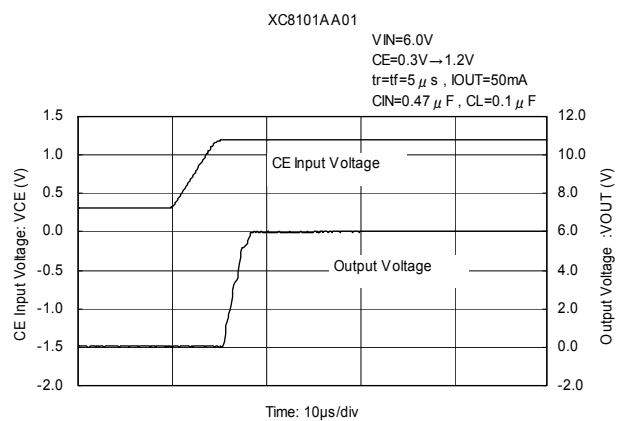
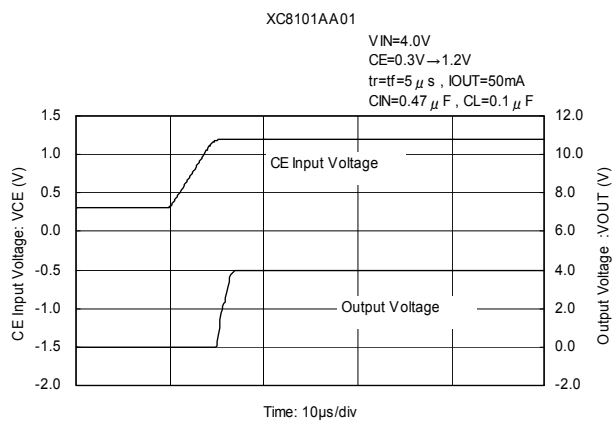
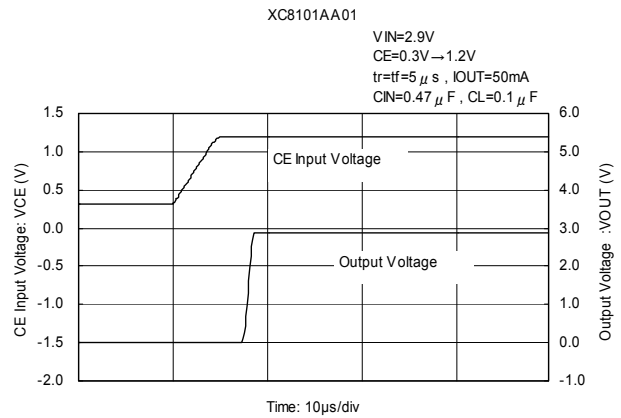
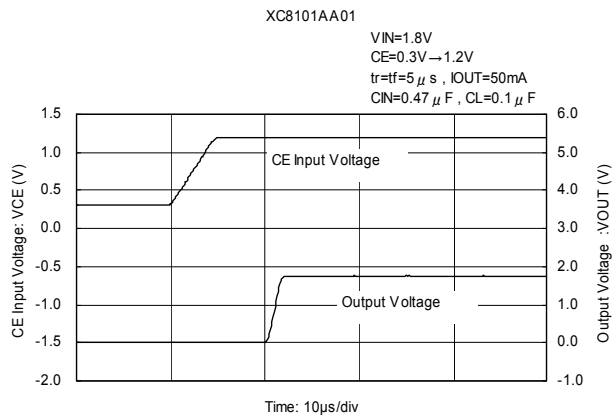
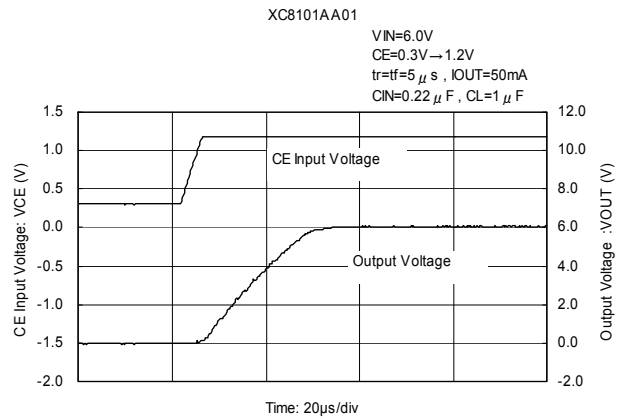
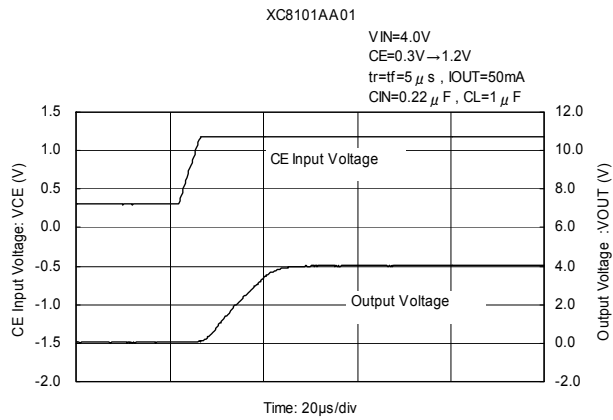

## TYPICAL PERFORMANCE CHARACTERISTICS (Continued)

### (8) Output Turn-on Time with CE (Continued)

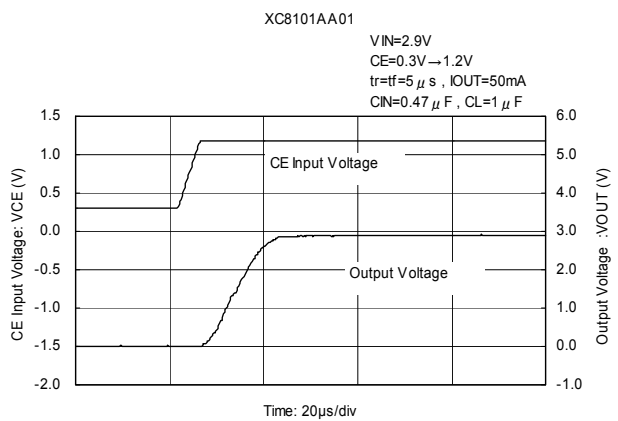
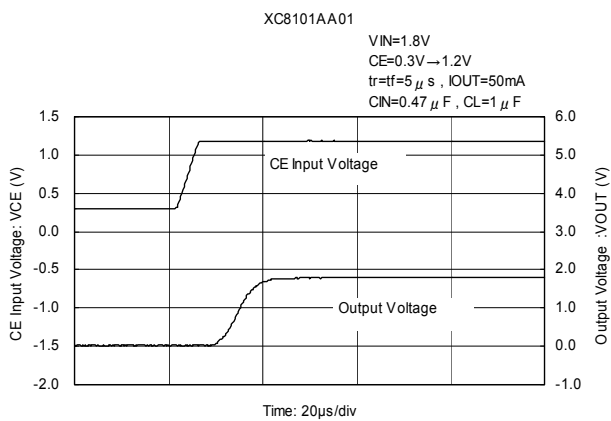
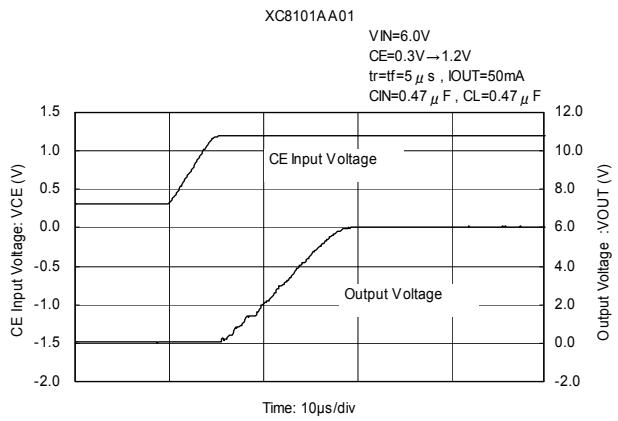
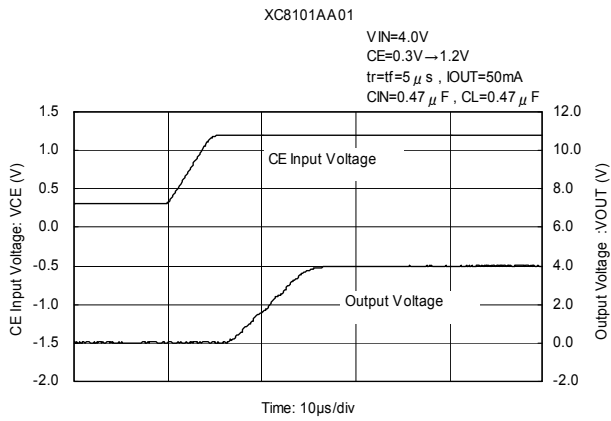
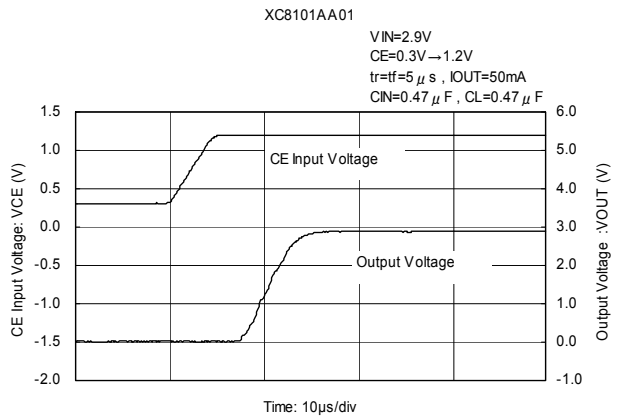
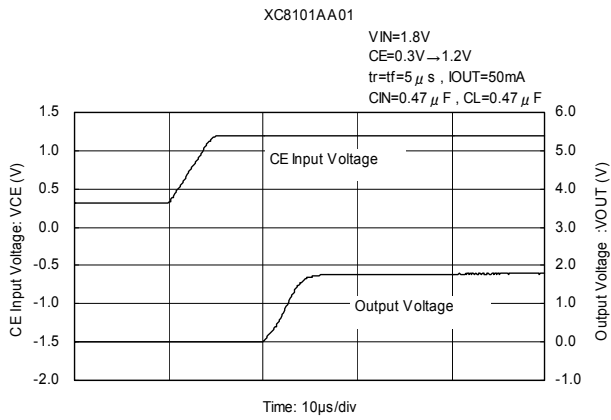

## TYPICAL PERFORMANCE CHARACTERISTICS (Continued)

### (8) Output Turn-on Time with CE (Continued)

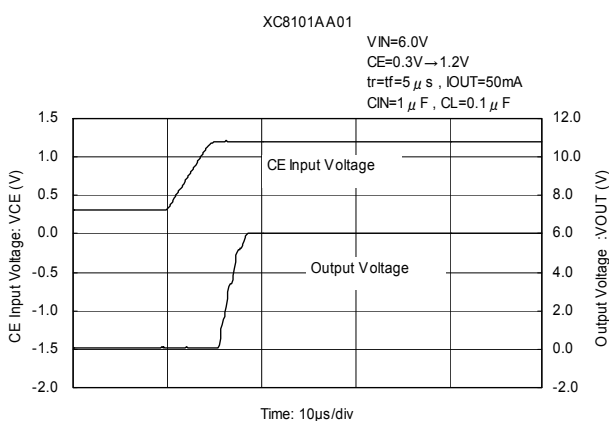
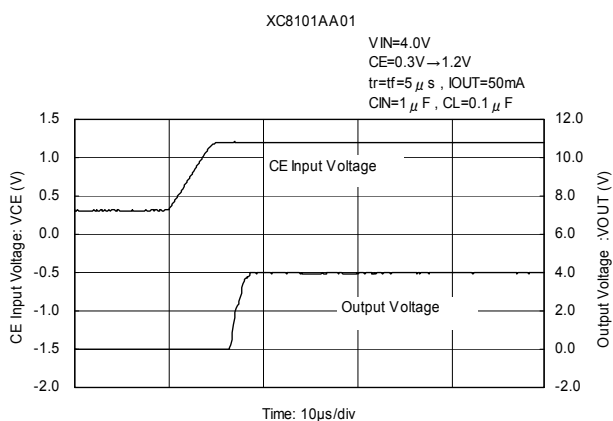
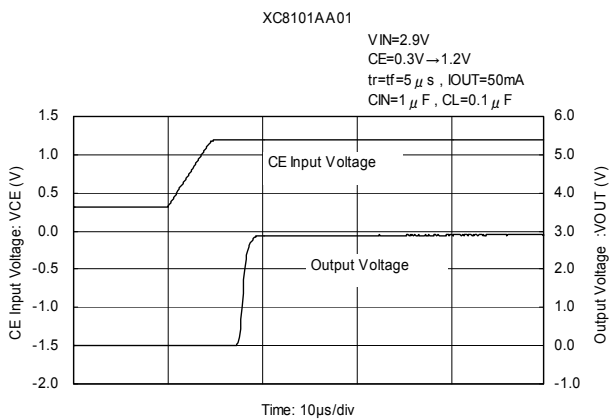
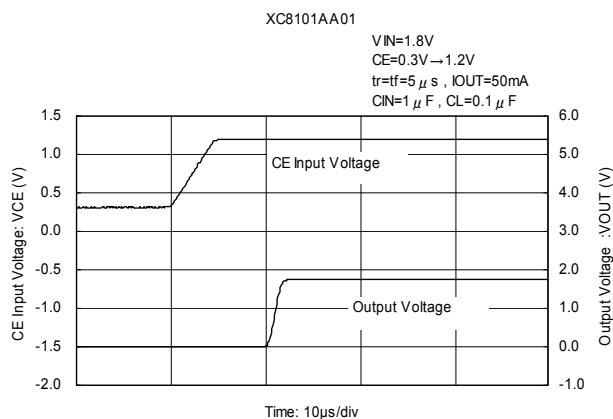
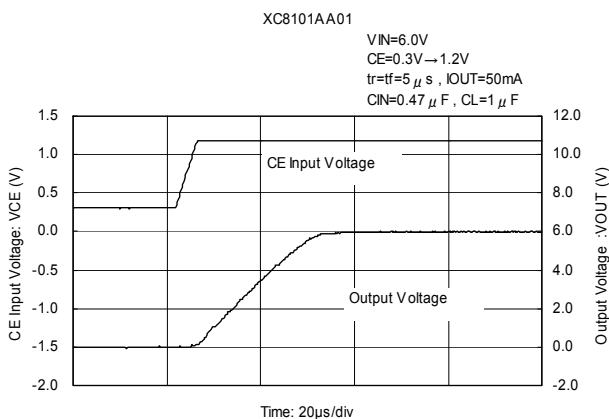
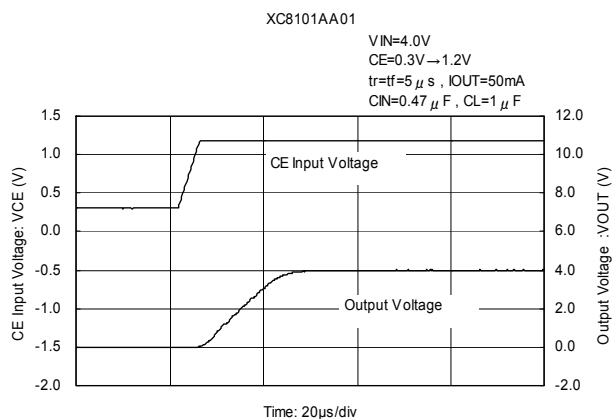

## TYPICAL PERFORMANCE CHARACTERISTICS (Continued)

### (8) Output Turn-on Time with CE (Continued)

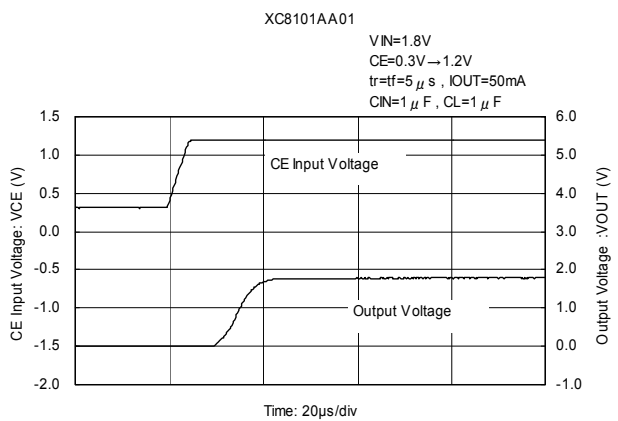
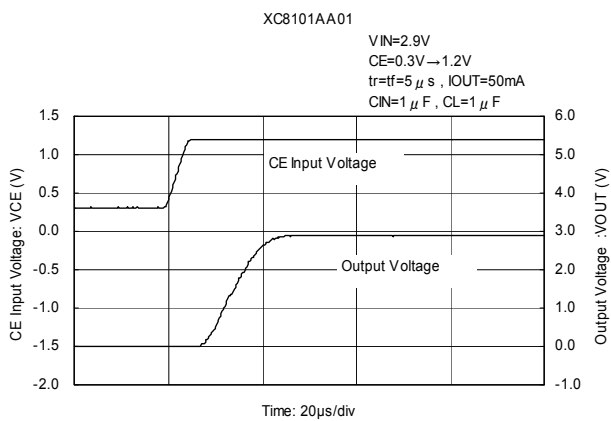
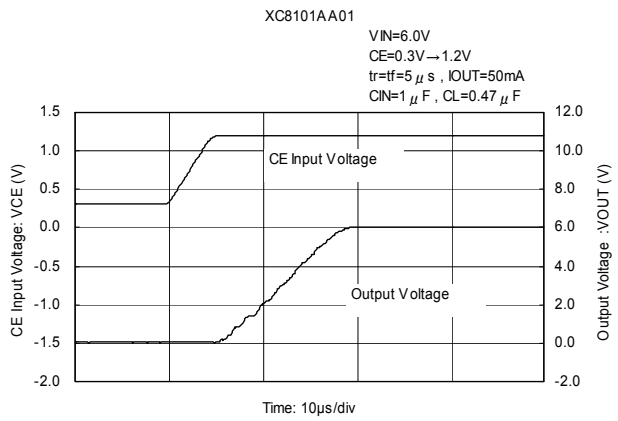
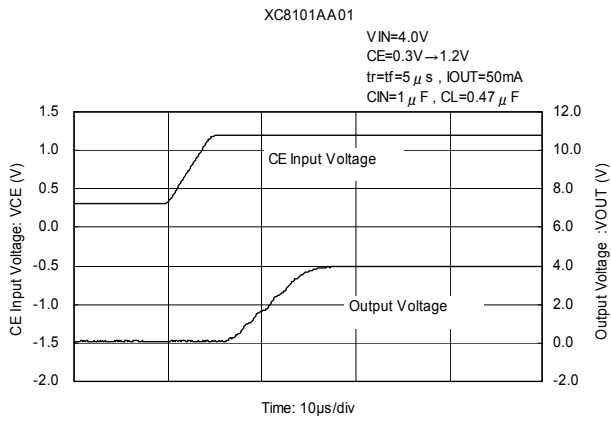
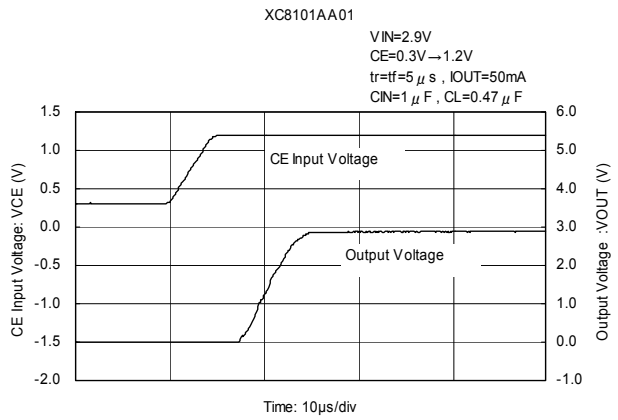
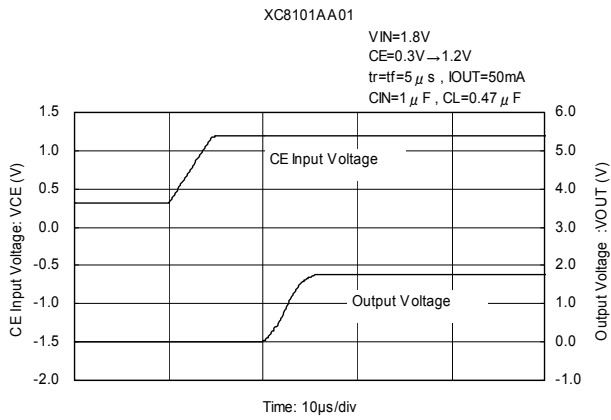

## TYPICAL PERFORMANCE CHARACTERISTICS (Continued)

### (8) Output Turn-on Time with CE (Continued)

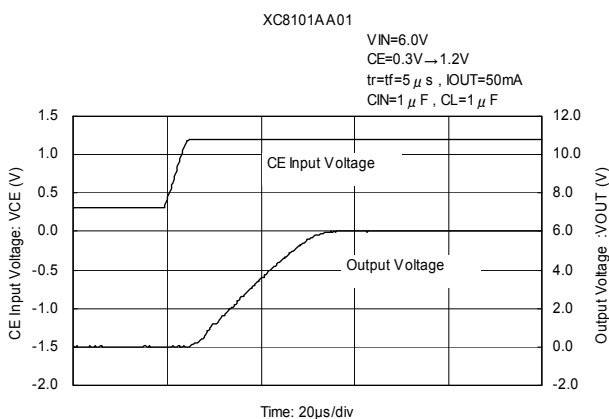
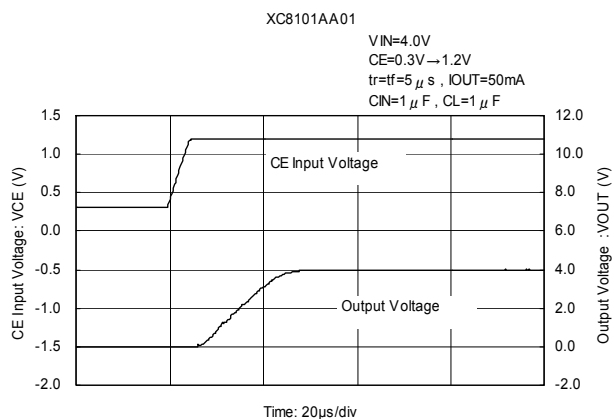

### (9) Output Turn-off Time with CE

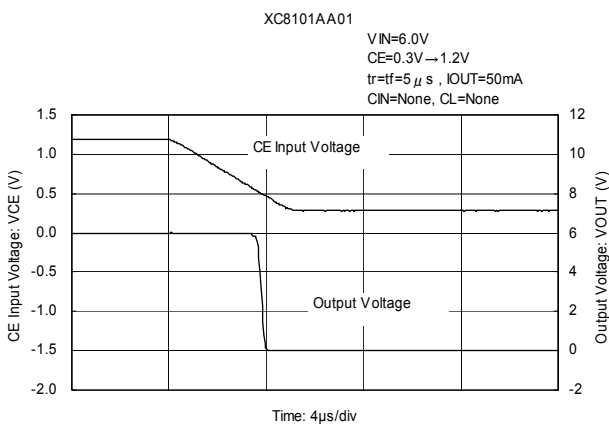
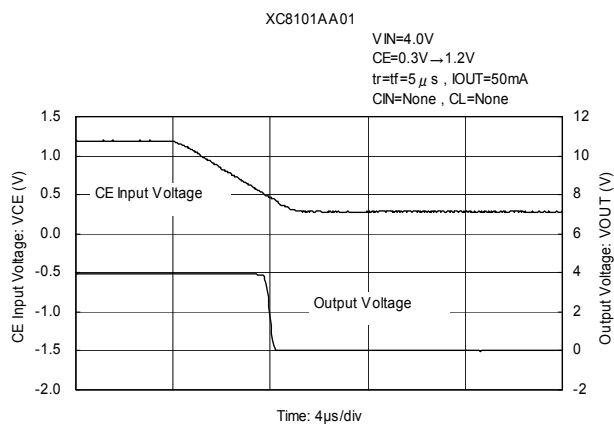
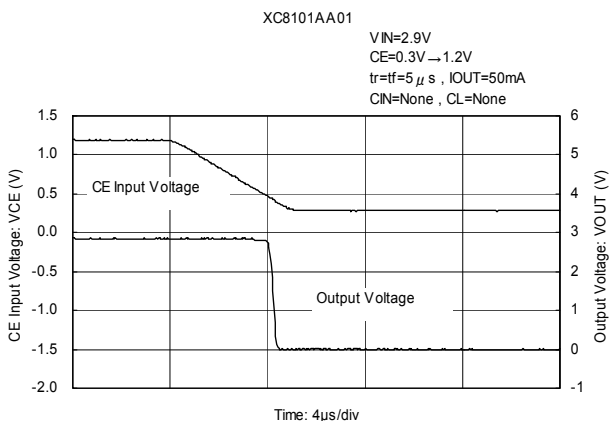
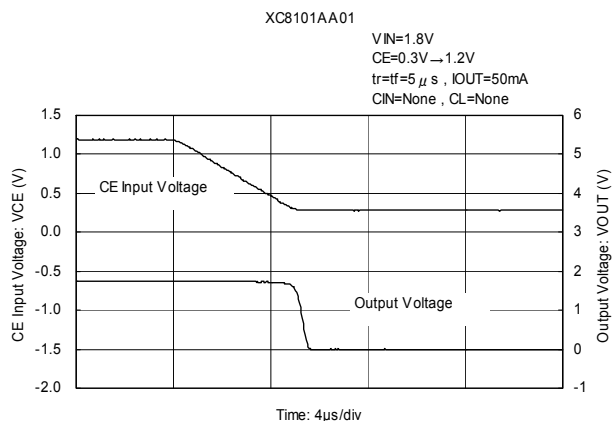

## TYPICAL PERFORMANCE CHARACTERISTICS (Continued)

### (9) Output Turn-off Time with CE (Continued)

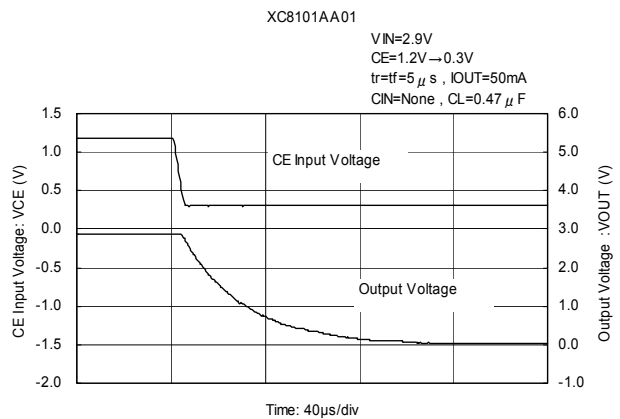
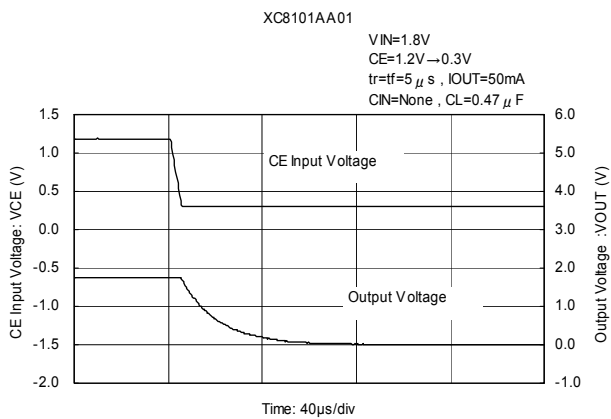
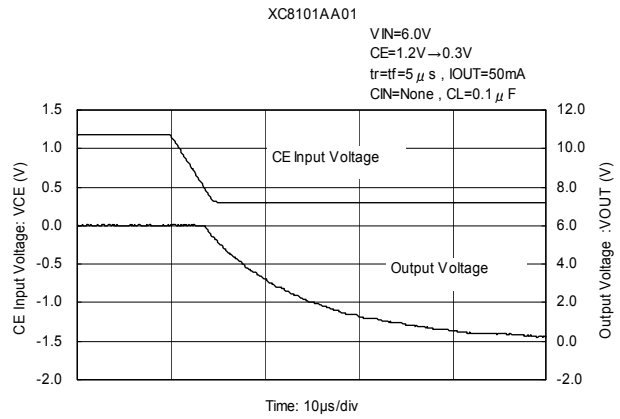
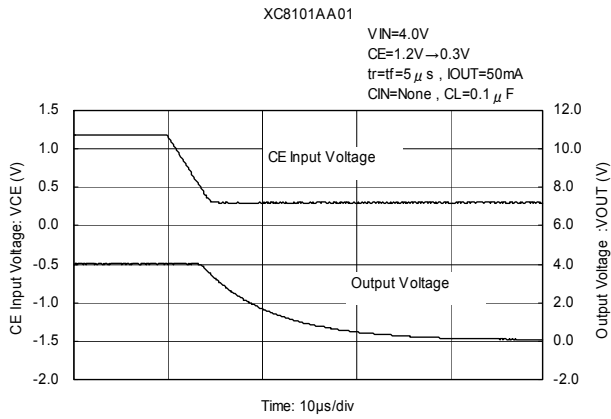
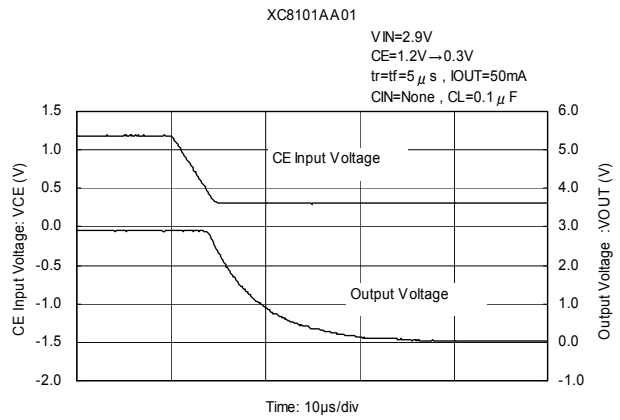
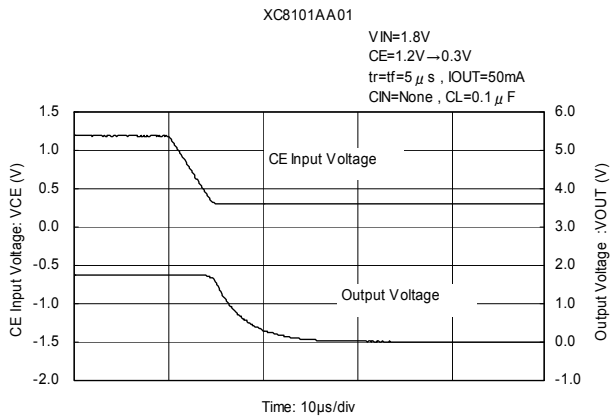

## TYPICAL PERFORMANCE CHARACTERISTICS (Continued)

### (9) Output Turn-off Time with CE (Continued)

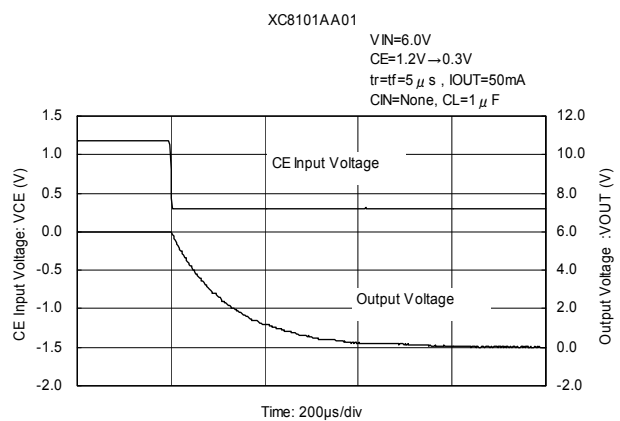
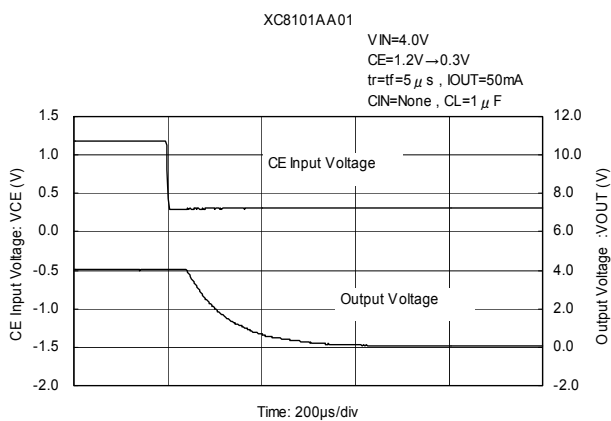
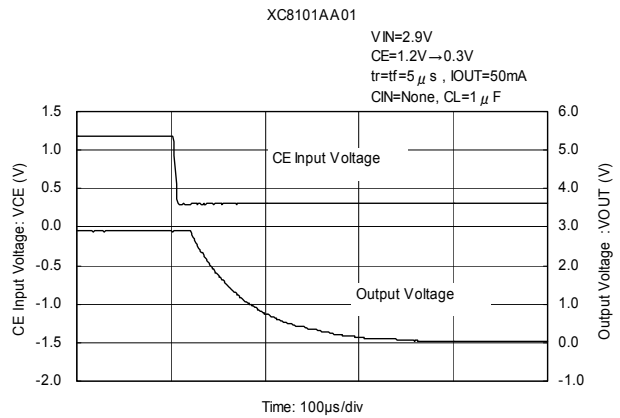
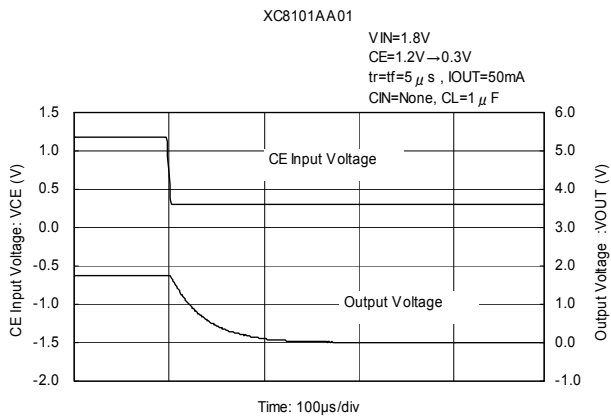
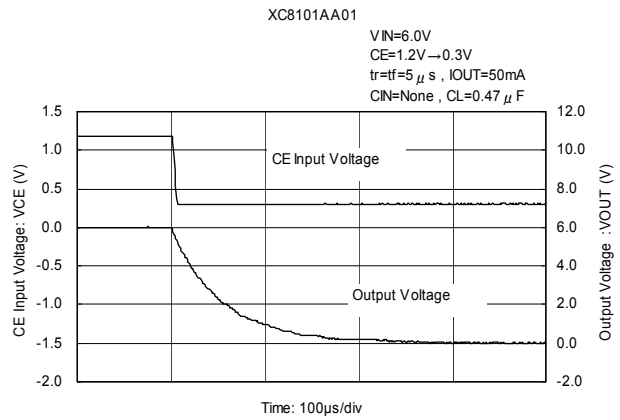
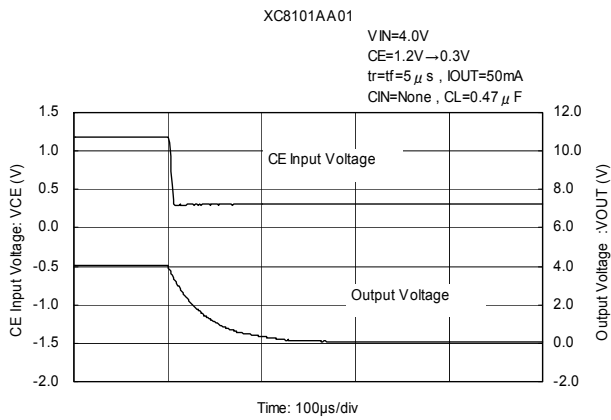

## TYPICAL PERFORMANCE CHARACTERISTICS (Continued)

### (9) Output Turn-off Time with CE (Continued)

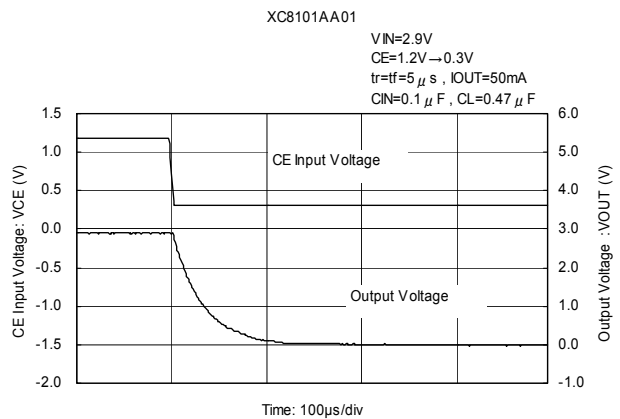
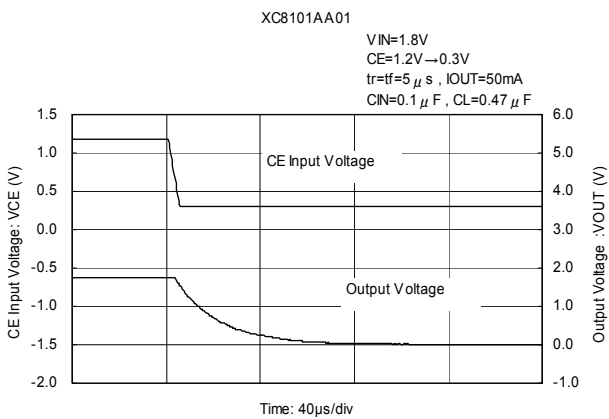
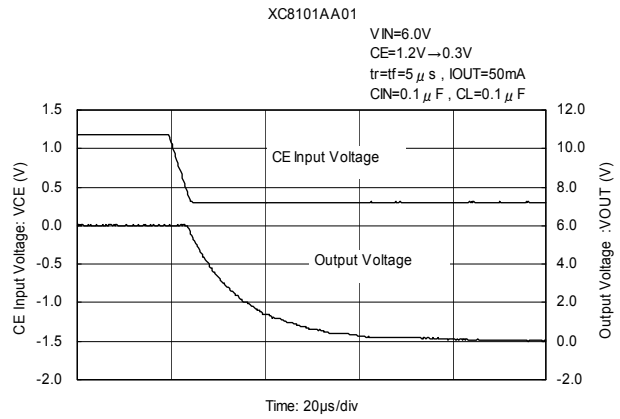
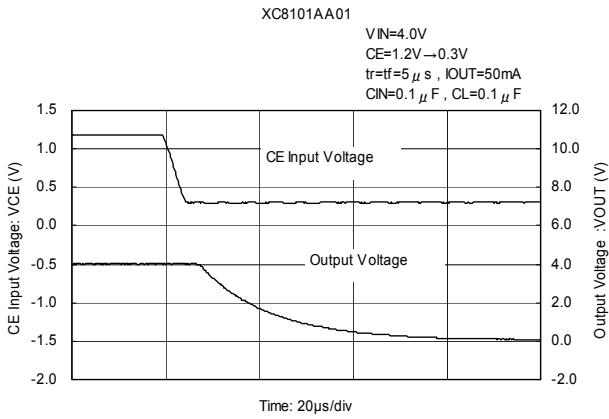
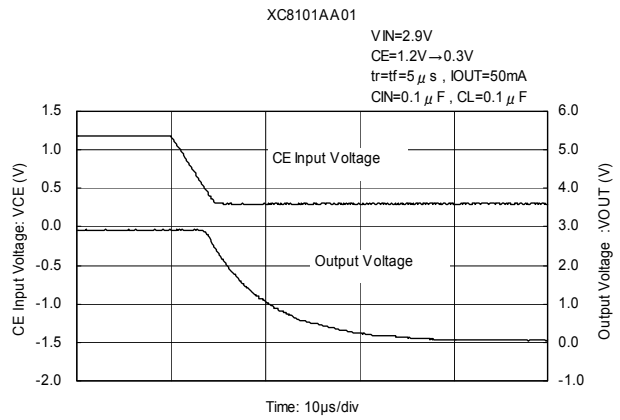
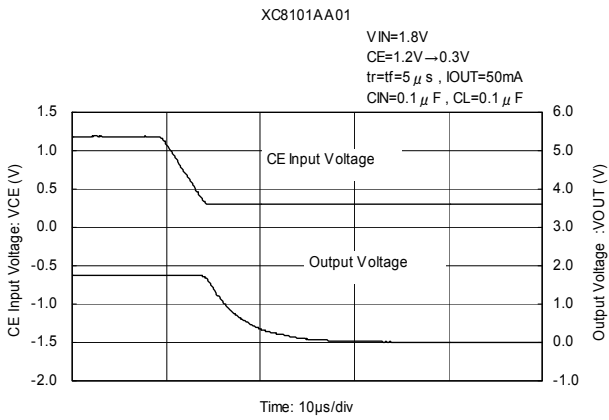



## TYPICAL PERFORMANCE CHARACTERISTICS (Continued)

### (9) Output Turn-off Time with CE (Continued)

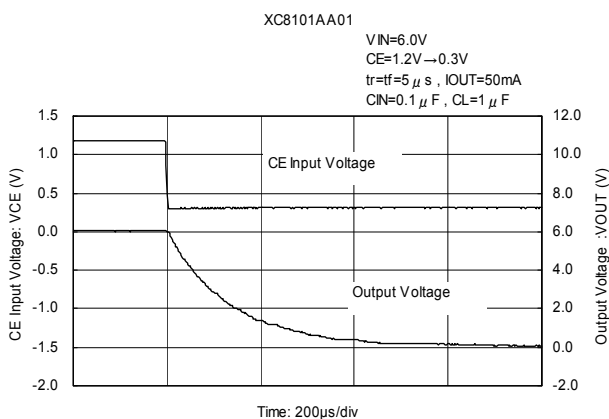
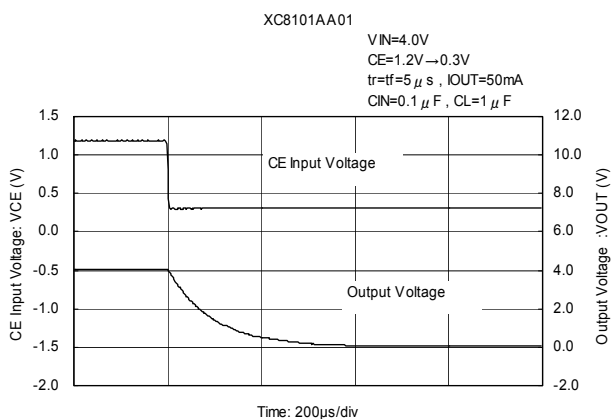
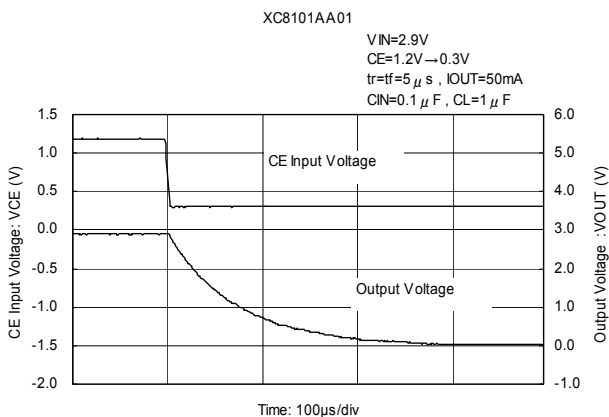
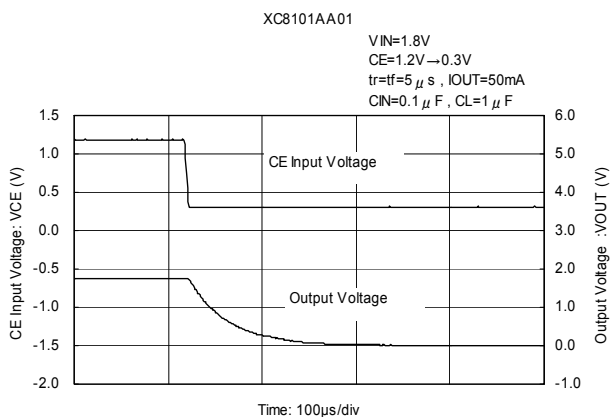
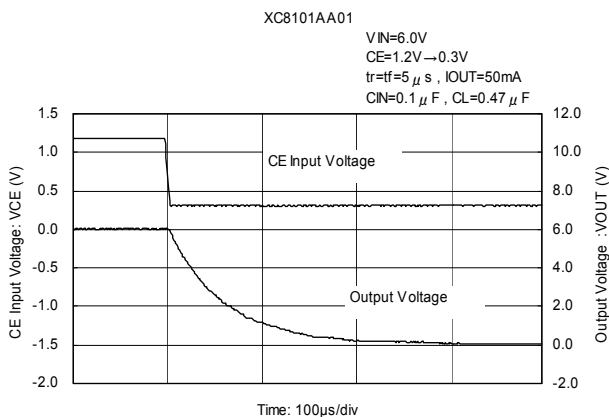
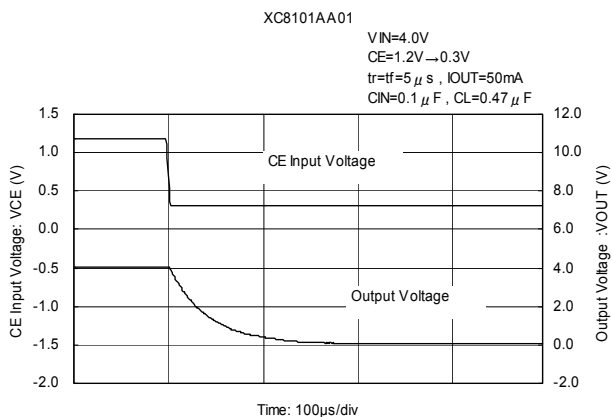

## TYPICAL PERFORMANCE CHARACTERISTICS (Continued)

### (9) Output Turn-off Time with CE (Continued)

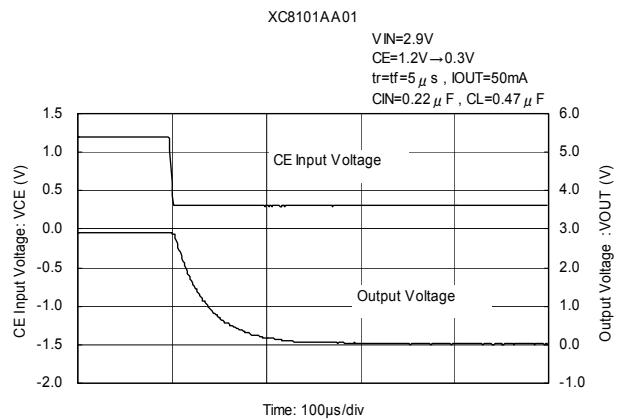
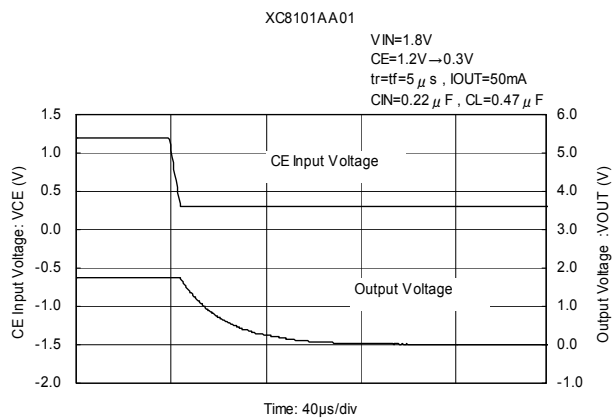
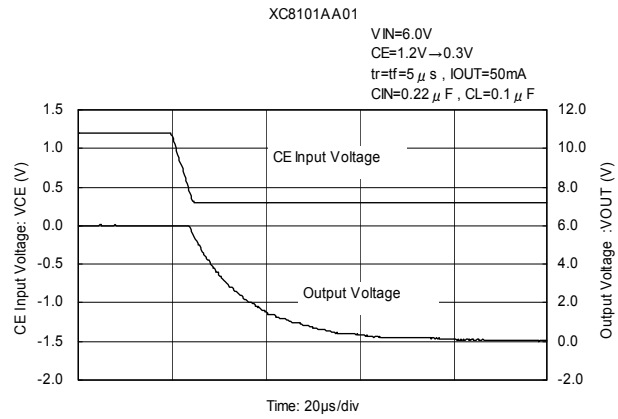
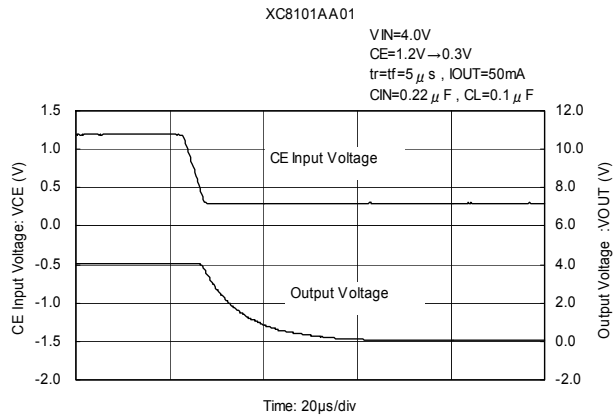
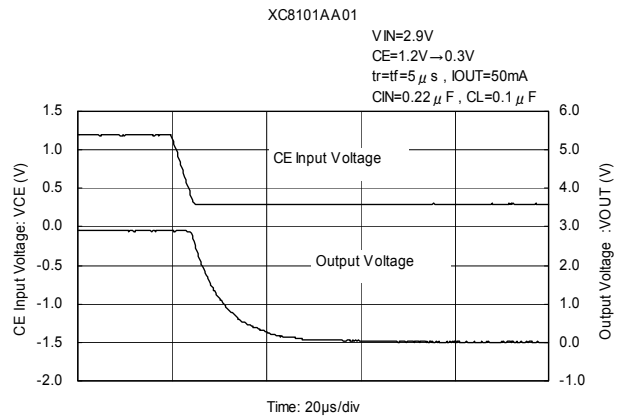
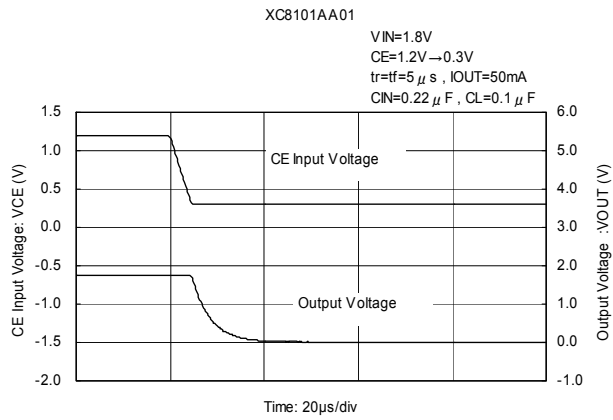

## TYPICAL PERFORMANCE CHARACTERISTICS (Continued)

### (9) Output Turn-off Time with CE (Continued)

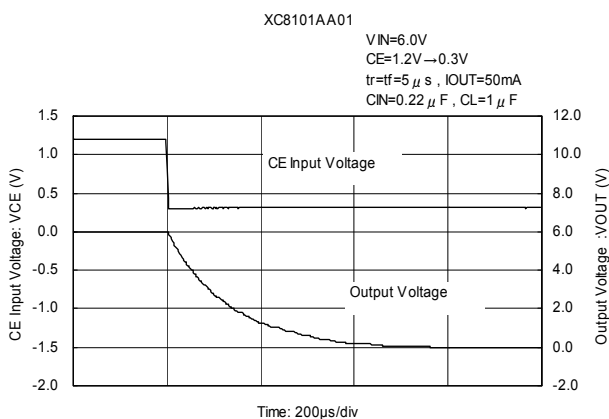
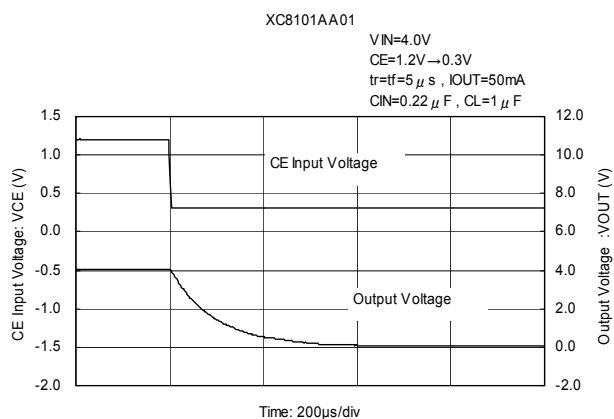
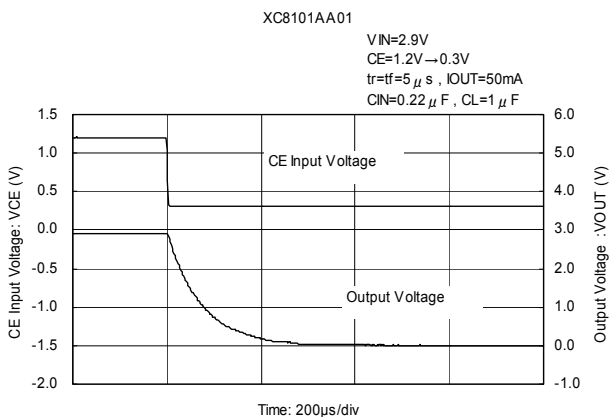
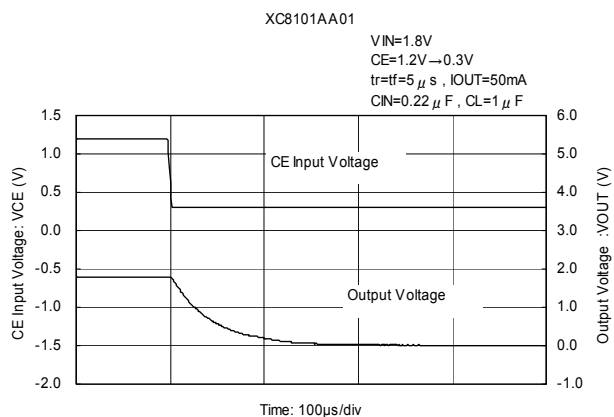
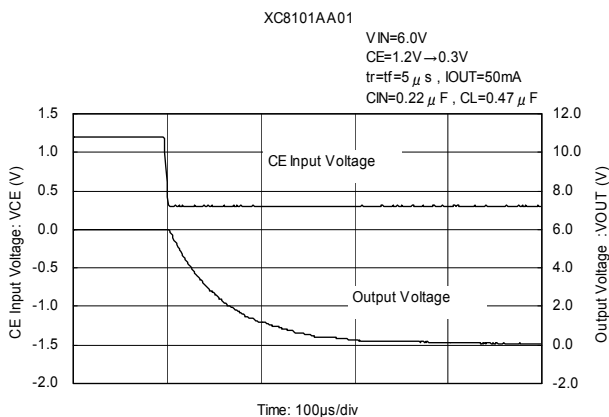
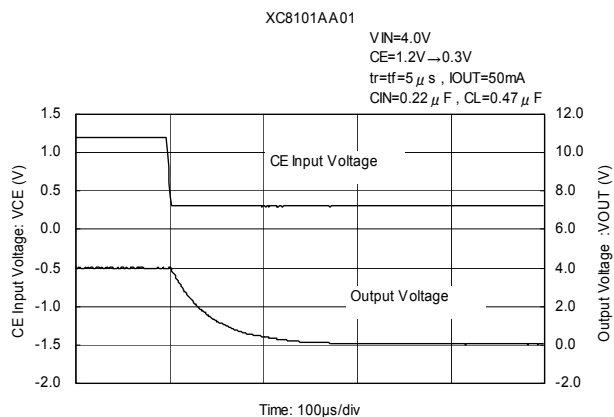

## TYPICAL PERFORMANCE CHARACTERISTICS (Continued)

### (9) Output Turn-off Time with CE (Continued)

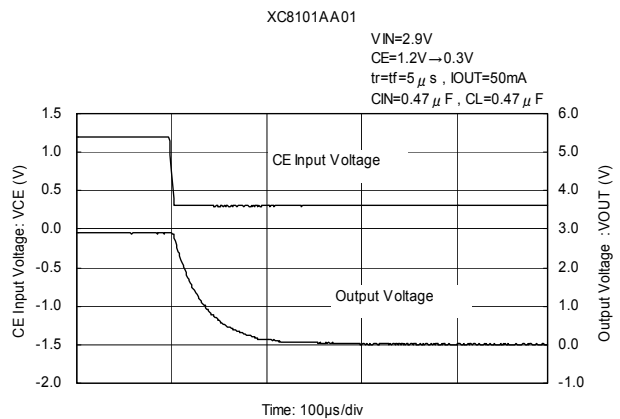
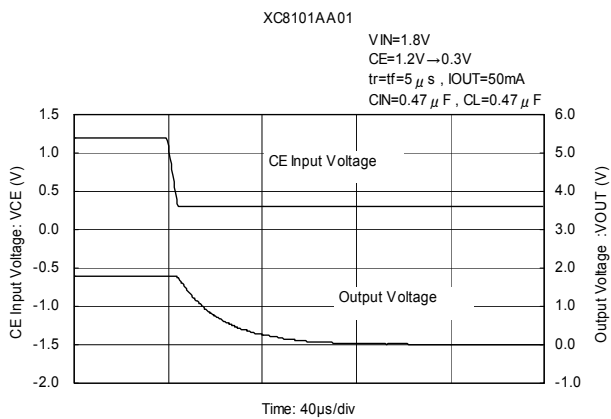
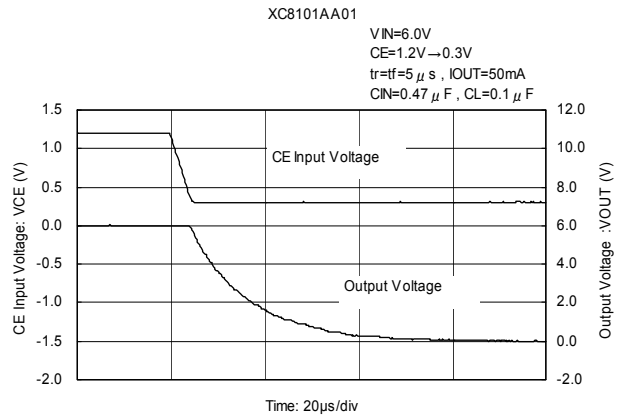
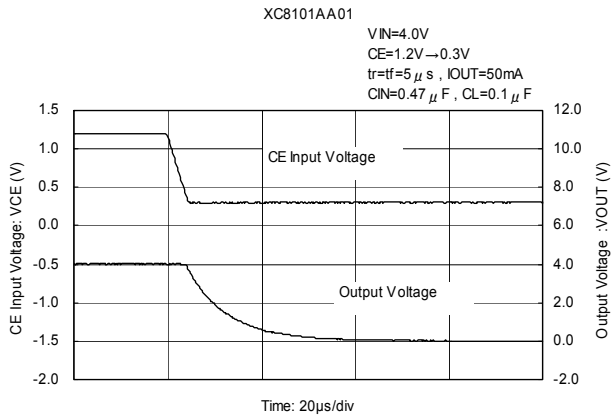
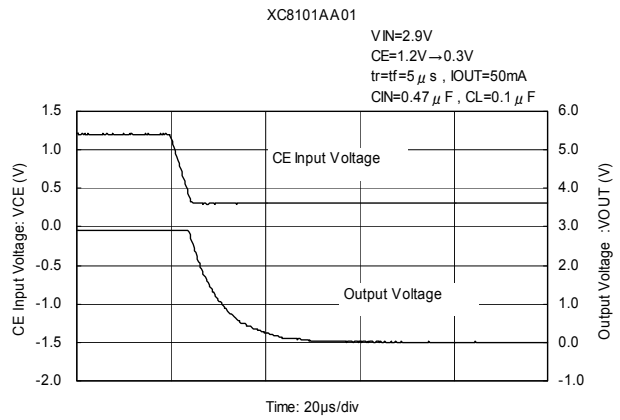
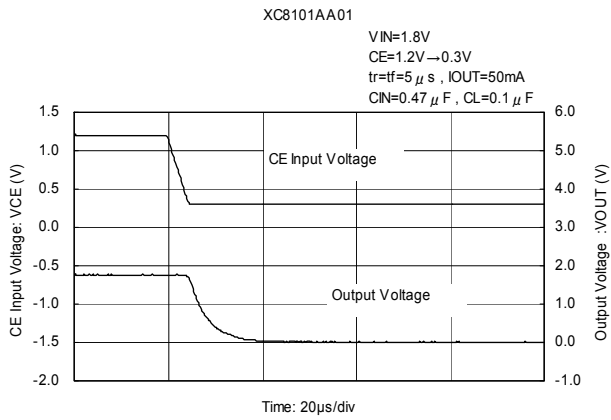

## TYPICAL PERFORMANCE CHARACTERISTICS (Continued)

### (9) Output Turn-off Time with CE (Continued)

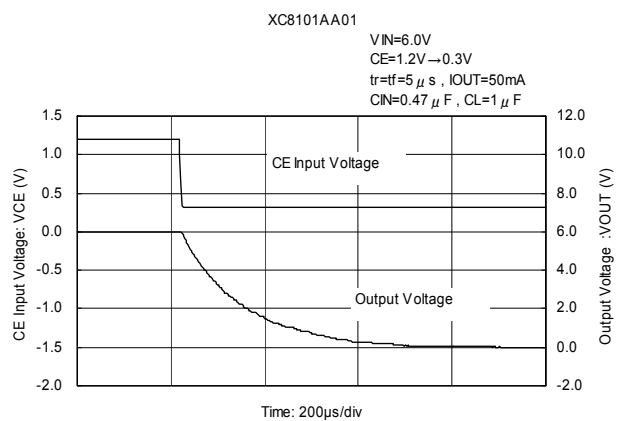
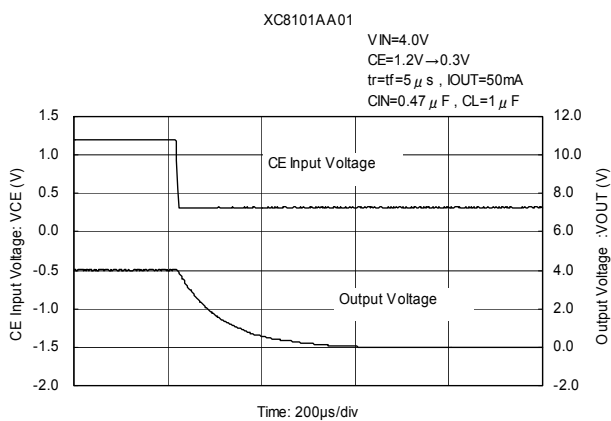
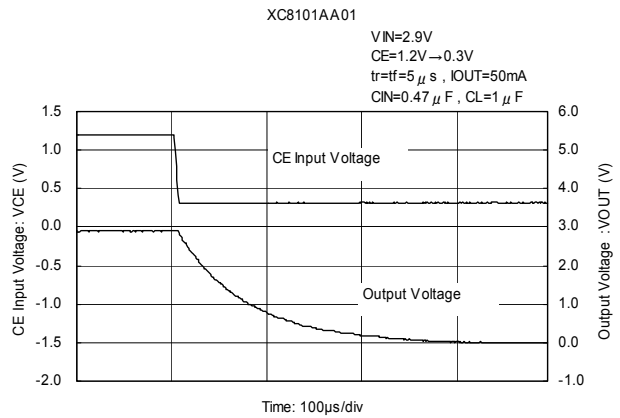
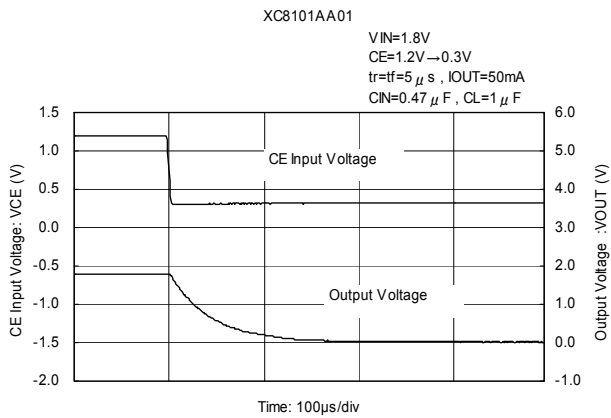
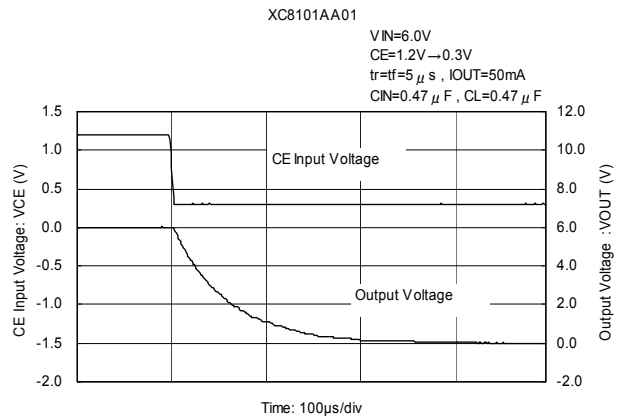
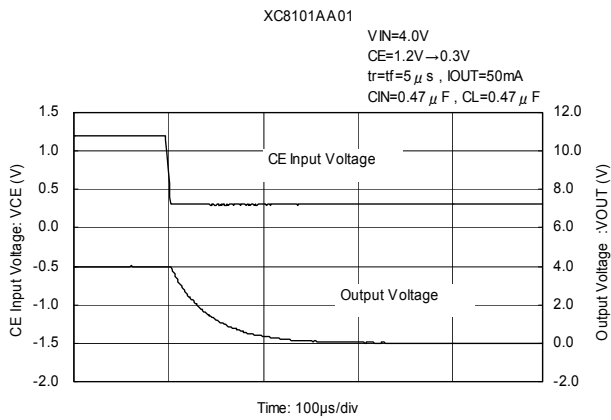

## TYPICAL PERFORMANCE CHARACTERISTICS (Continued)

### (9) Output Turn-off Time with CE (Continued)

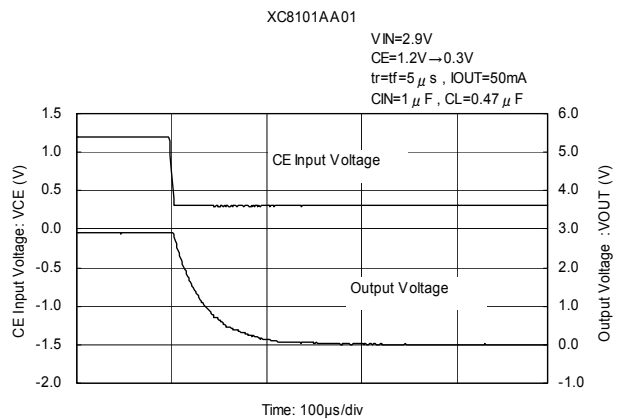
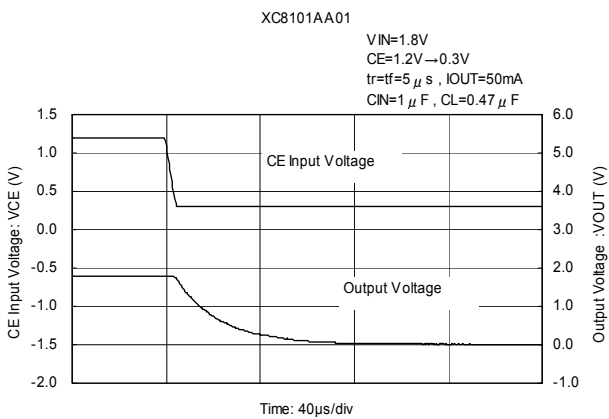
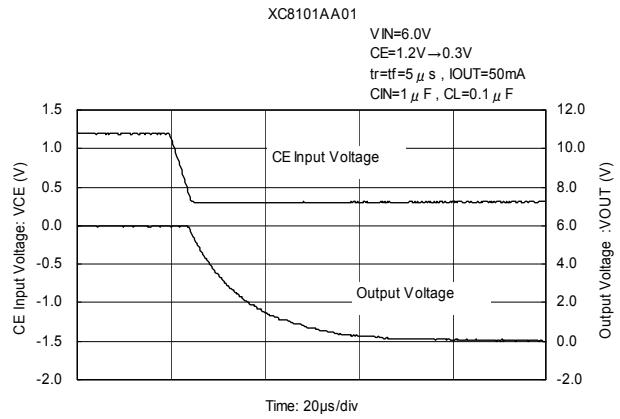
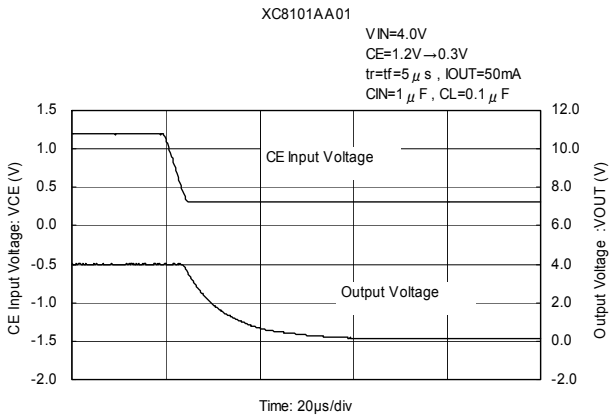
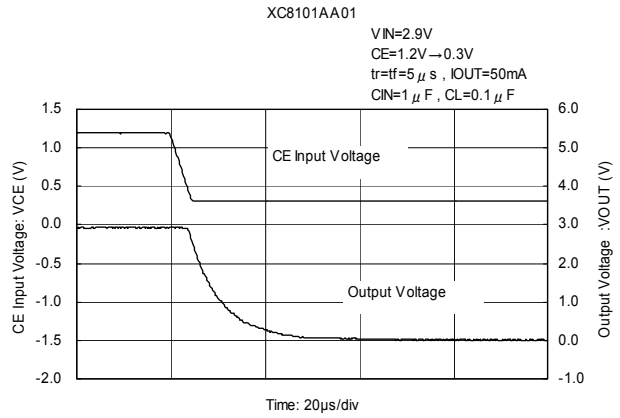
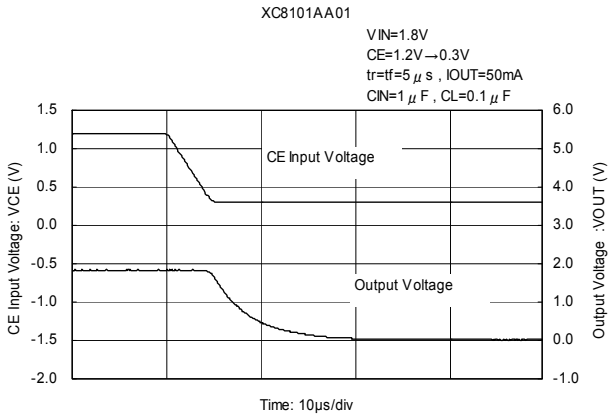

## TYPICAL PERFORMANCE CHARACTERISTICS (Continued)

### (9) Output Turn-off Time with CE (Continued)

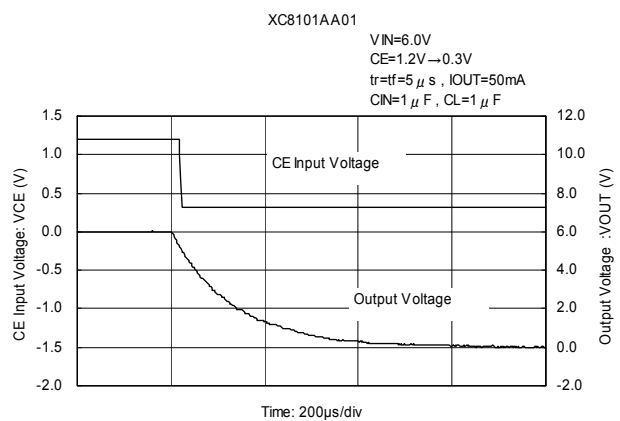
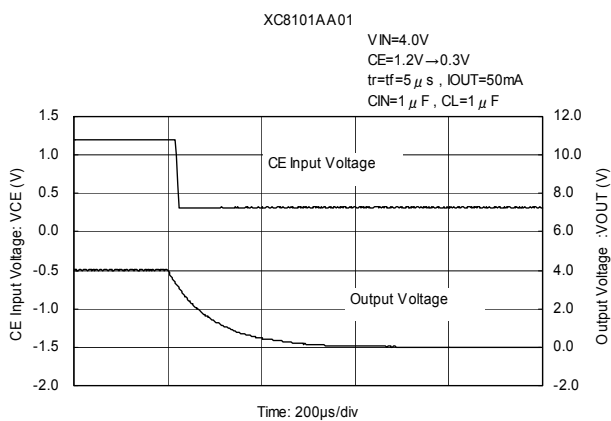
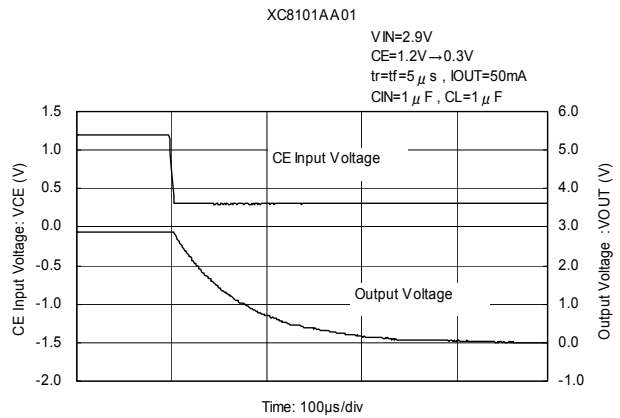
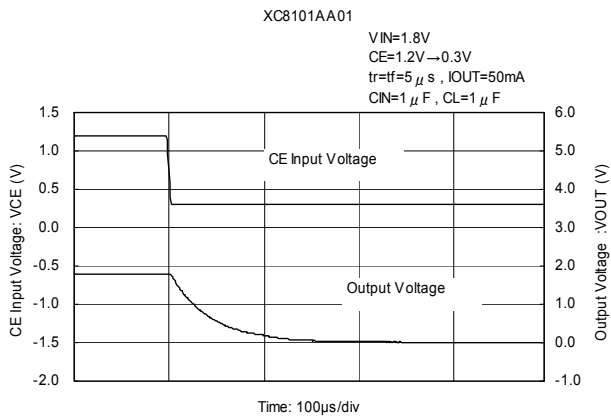
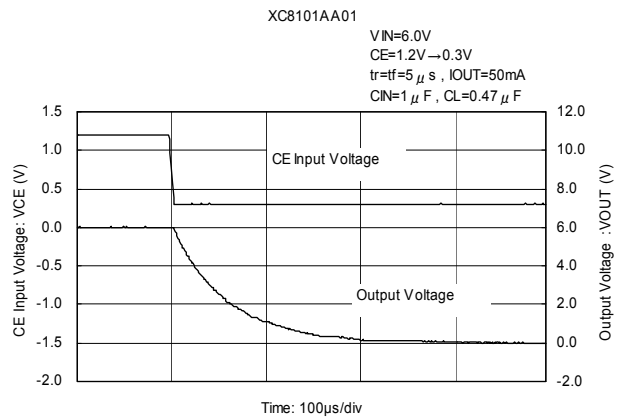
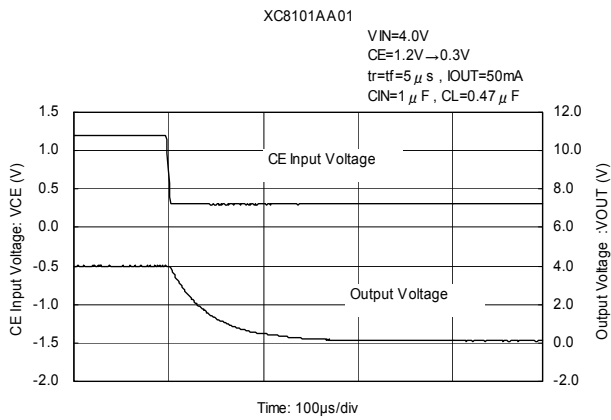

1. The products and product specifications contained herein are subject to change without notice to improve performance characteristics. Consult us, or our representatives before use, to confirm that the information in this datasheet is up to date.
2. We assume no responsibility for any infringement of patents, patent rights, or other rights arising from the use of any information and circuitry in this datasheet.
3. Please ensure suitable shipping controls (including fail-safe designs and aging protection) are in force for equipment employing products listed in this datasheet.
4. The products in this datasheet are not developed, designed, or approved for use with such equipment whose failure or malfunction can be reasonably expected to directly endanger the life of, or cause significant injury to, the user.  
(e.g. Atomic energy; aerospace; transport; combustion and associated safety equipment thereof.)
5. Please use the products listed in this datasheet within the specified ranges.  
Should you wish to use the products under conditions exceeding the specifications, please consult us or our representatives.
6. We assume no responsibility for damage or loss due to abnormal use.
7. All rights reserved. No part of this datasheet may be copied or reproduced without the prior permission of TOREX SEMICONDUCTOR LTD.

**TOREX SEMICONDUCTOR LTD.**