



JEWEL HILL ELECTRONIC CO.,LTD.

**SPECIFICATIONS FOR
LCD MODULE**

Module No. GC5007

Office Address: Rm. 518,5/F., 101 Shangbu Industrial District,
HuaqiangNorthRoad, Shenzhen, China

TEL : (86)-755-83362489 83617492

FAX: (86)-755-83286396 83365871

E-mail: sales@jewelhillelectronic.com
jlcd@21cn.com

Website: www.jewelhillelectronic.com

TABLE OF CONTENTS

LCM NUMBER SYSTEM	2
1. GENERAL DESCRIPTION	3
2. FEATURES.....	3
3. MECHANICAL SPECIFICATION	3
4. MECHANICAL DIMENSION	4
5. MAXIMUM RATINGS	5
6. ELECTRICAL CHARACTERISTICS	5
7. MODULE FUNCTION DESCRIPTION	6
8. ELECTRO-OPTICAL CHARACTERISTICS	10
9. RELIABILITY.....	13
10. PRECAUTIONS FOR USING LCD MODULES	14
11. USING LCD MODULES.....	16
12. REVISION HISTORY	18
SAMPLE APPROVED REPORT	19

LCM Number System

GC 5007 C O D W N T N O-V00-C W N X

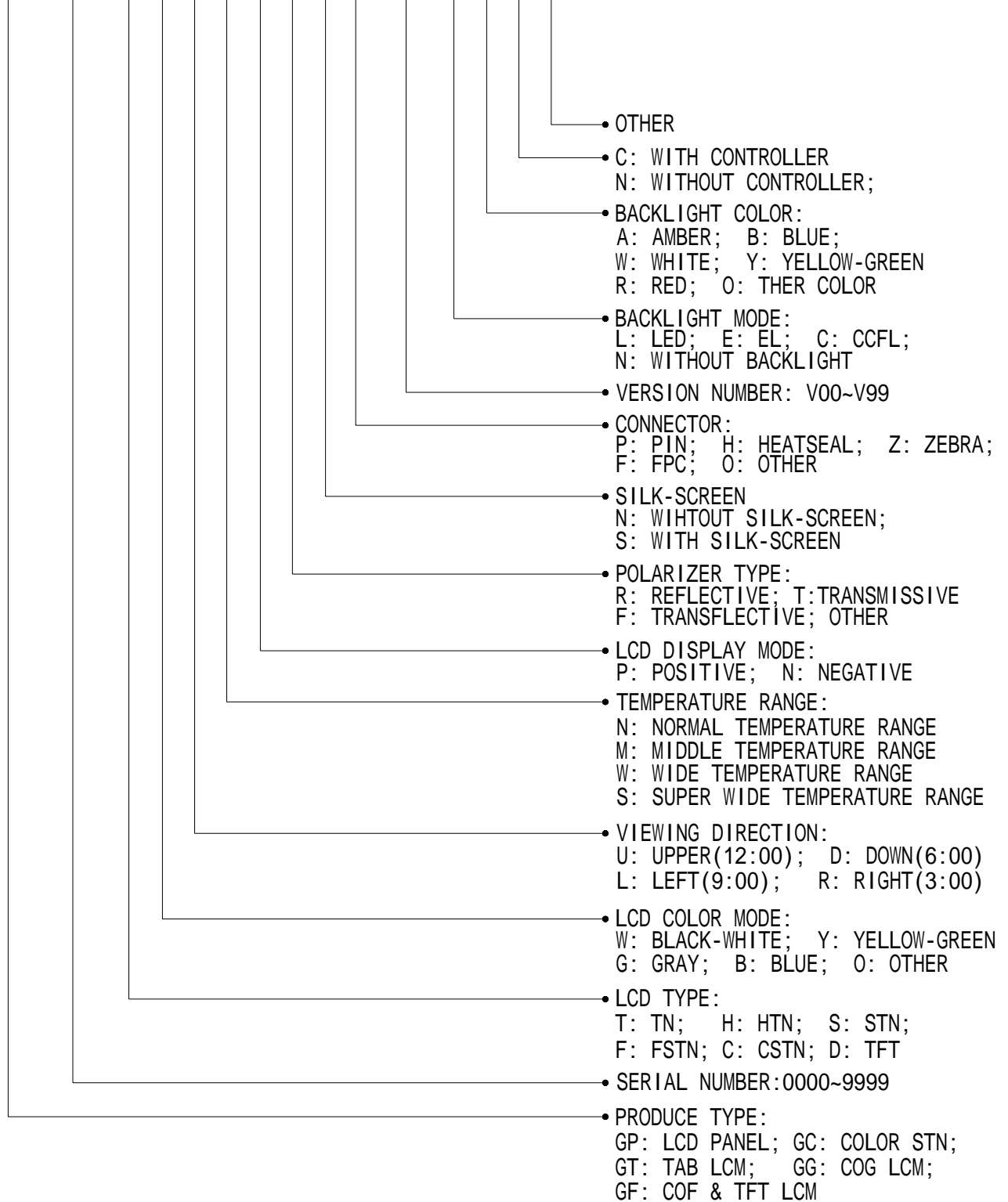

1. GENERAL DESCRIPTION

The GC5007 is a 320(RGB) x 240 Dots LCD module. It has a C-STN panel composed of 320 x 3 segments and 240 commons. The LCM can be easily accessed via parallel interface.

2. FEATURES

Display Mode	Transmissive and Negative
	65Kcolor CSTN module
Display Color	Decided by the Controller
BackGround	Black(Rea, Green, Blue Dots are OFF atate)
Display Format	320x240 Dots
Input Data	8 bit parallel data transfer
Multiplexing Ratio	1/240 Duty
Bias	1/17 Bias
Viewing Direction	6 O'clock
Driving IC	IST3224TA0
Backlight	CCFL(White)

3. MECHANICAL SPECIFICATION

Item	Specifications	Unit
Screen Size	5.7	inch
Dimensional outline	158.5(W) x 109.0(H) x 8.5(T)	mm
Resolution	320(RGB) x 240	dots
Vewing area	119.38(W) x 90.38(H)	mm
Active area	115.18(W) x 86.38 (H)	mm
Dots pitch	0.36 (W)×0.36(H)	mm
Dots size	0.345(W)×0.345(H)	mm
Approx. weight	TBD	g

4. MECHANICAL DIMENSION

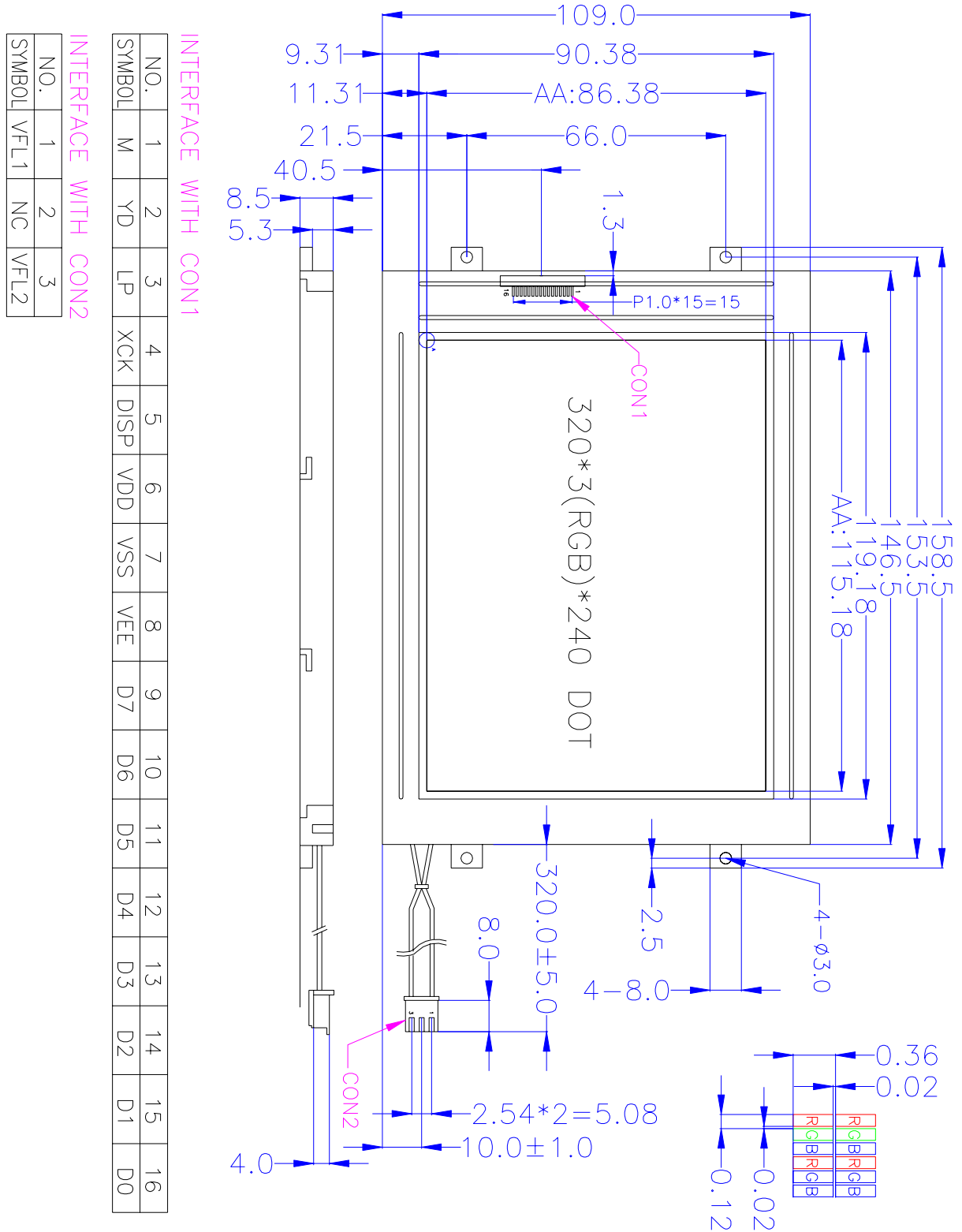

5. MAXIMUM RATINGS

Item	Symbol	Min	Max	Unit	Note
Supply voltage	$V_{DD} - V_{SS}$	-0.3	6.0	V	
	V_{LCD}	-0.3	40.0	V	
Input Voltage	V_{IN}	-0.3	$V_{DD}+0.3$	V	
Operating temperature	T_{OPR}	-10	+60		
Storage temperature	T_{STR}	-20	+70		
Humidity	---	---	90	%RH	

6. ELECTRICAL CHARACTERISTICS

Item		Symbol	Condition	Min.	Typ.	Max.	Unit
Supply Voltage	Logic	V_{DD}	---	-	5.0	-	V
Input Voltage	H level	V_{IH}	---	$0.8V_{DD}$	---	V_{DD}	V
	L level	V_{IL}		V_{SS}	---	$0.2V_{DD}$	
Current Consumption		I_{DD}	$V_{DD}=5V; T_{amb}=25$;	---	1.5	2.0	mA
LCD Driving Voltage		V_{LCD}	Bias=1/17 $V_{LCD}=V_{EE}-V_{SS}$	---	23.0	---	V

7. MODULE FUNCTION DESCRIPTION

7.1. PIN DESCRIPTION

CON1:

Pin No.	Symbol	Description
1	M	Input of Signal to AC Electrify the LCD Driver Output
2	YD	Scan Start Pulse
3	LP	Display Data Latch Pulse Input
4	XCK	Display Data Shift Colok Input
5	DISPOFF	Display ON/OFF Selection
6	VDD	Power Supply for Positive
7	VSS	Power Supply for Ground
8	VEE	LCD Driver Voltage Input
9	D7	Data Bit 7
10	D6	Data Bit 6
11	D5	Data Bit 5
12	D4	Data Bit 4
13	D3	Data Bit 3
14	D2	Data Bit 2
15	D1	Data Bit 1
16	D0	Data Bit 0

CON2

1	VFL1	Supply Voltage for CCFL
2	NC	No Connect
3	VFL2	Supply Voltage for CCFL

7.2 TIMING CHARACTERISTICS

7.2.1 Segment mode

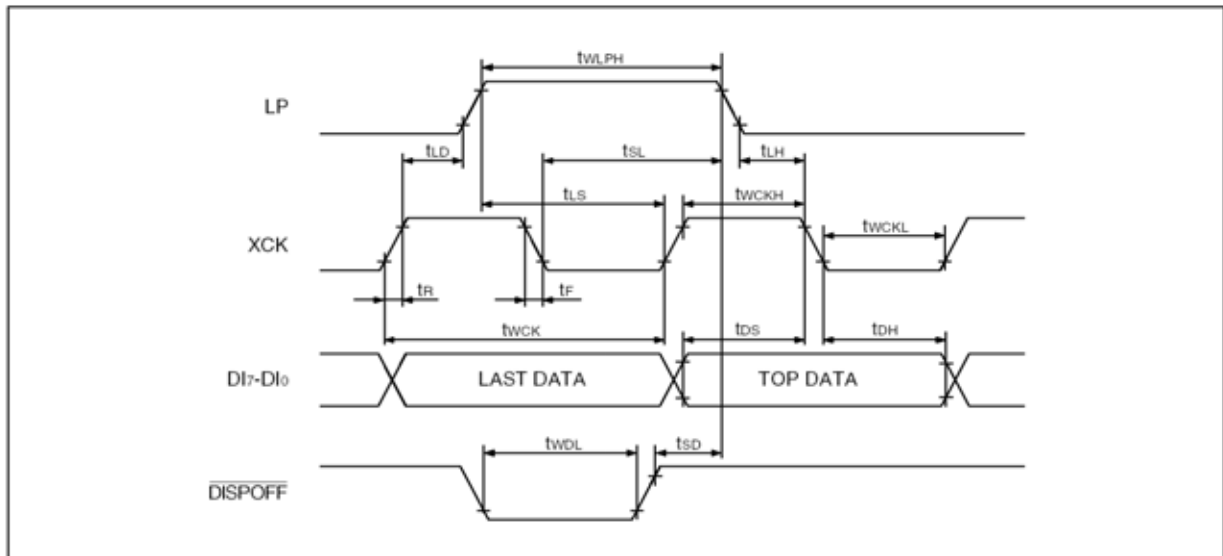

($V_{SS} = V_5 = 0\text{ V}$, $V_{DD} = +5.0 \pm 0.5\text{ V}$, $V_0 = +15.0\text{ to }+42.0\text{ V}$, $T_{OPR} = -20\text{ to }+85\text{ }^\circ\text{C}$)

PARAMETER	SYMBOL	CONDITIONS	MIN.	TYP.	MAX.	UNIT	NOTE
Shift clock period	twCK	$t_R, t_F \leq 10\text{ ns}$	50			ns	1
Shift clock "H" pulse width	twCKH		15			ns	
Shift clock "L" pulse width	twCKL		15			ns	
Data setup time	tDS		10			ns	
Data hold time	tDH		12			ns	
Latch pulse "H" pulse width	twLPH		15			ns	
Shift clock rise to latch pulse rise time	tLD		0			ns	
Shift clock fall to latch pulse fall time	tSL		30			ns	
Latch pulse rise to shift clock rise time	tLS		25			ns	
Latch pulse fall to shift clock fall time	tLH		25			ns	
Enable setup time	tS		10			ns	
Input signal rise time	tR				50	ns	2
Input signal fall time	tF				50	ns	2
DISPOFF removal time	tSD		100			ns	
DISPOFF "L" pulse width	twDL		1.2			μs	
Output delay time (1)	td	$C_L = 15\text{ pF}$			30	ns	
Output delay time (2)	tpD1, tpD2	$C_L = 15\text{ pF}$			1.2	μs	
Output delay time (3)	tpD3	$C_L = 15\text{ pF}$			1.2	μs	

NOTES :

1. Takes the cascade connection into consideration.
2. $(twCK - twCKH - twCKL)/2$ is maximum in the case of high speed operation.

7.2.2 Common Mode

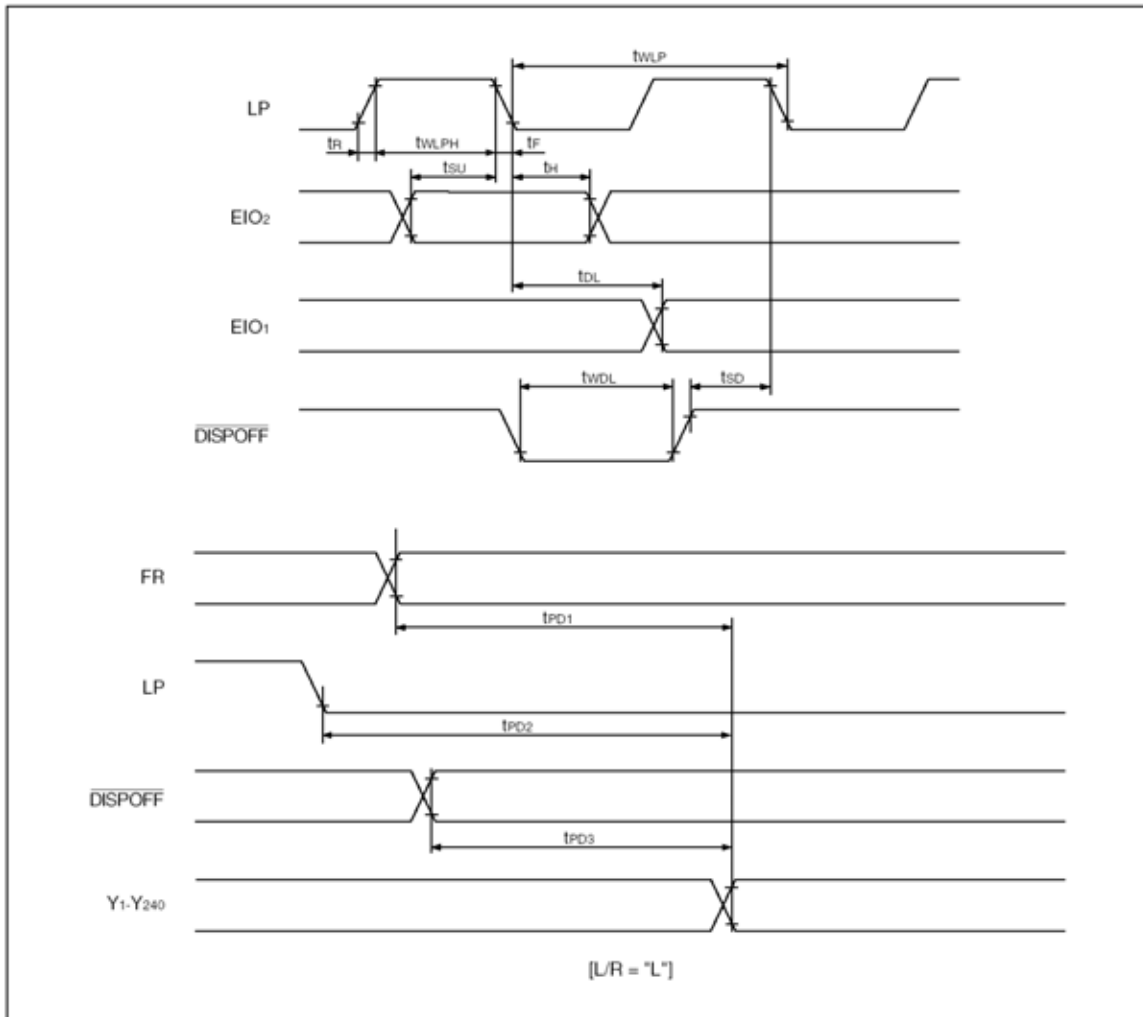

($V_{SS} = V_5 = 0\text{ V}$, $V_{DD} = +2.5\text{ to }+5.5\text{ V}$, $V_0 = +15.0\text{ to }+42.0\text{ V}$, $T_{OPR} = -20\text{ to }+85\text{ }^\circ\text{C}$)

PARAMETER	SYMBOL	CONDITIONS	MIN.	TYP.	MAX.	UNIT
Shift clock period	t_{wLP}	$t_R, t_F \leq 20\text{ ns}$	250			ns
Shift clock "H" pulse width	t_{wLPH}	$V_{DD} = +5.0 \pm 0.5\text{ V}$	15			ns
Data setup time	t_{SU}		30			ns
Data hold time	t_H		50			ns
Input signal rise time	t_R				50	ns
Input signal fall time	t_F				50	ns
DISPOFF removal time	t_{SD}		100			ns
DISPOFF "L" pulse width	t_{WDL}		1.2			μs
Output delay time (1)	t_{DL}	$C_L = 15\text{ pF}$			200	ns
Output delay time (2)	t_{PD1}, t_{PD2}	$C_L = 15\text{ pF}$			1.2	μs
Output delay time (3)	t_{PD3}	$C_L = 15\text{ pF}$			1.2	μs

7.3 APPLICATION EXAMPLES

■ BLOCK DIAGRAM

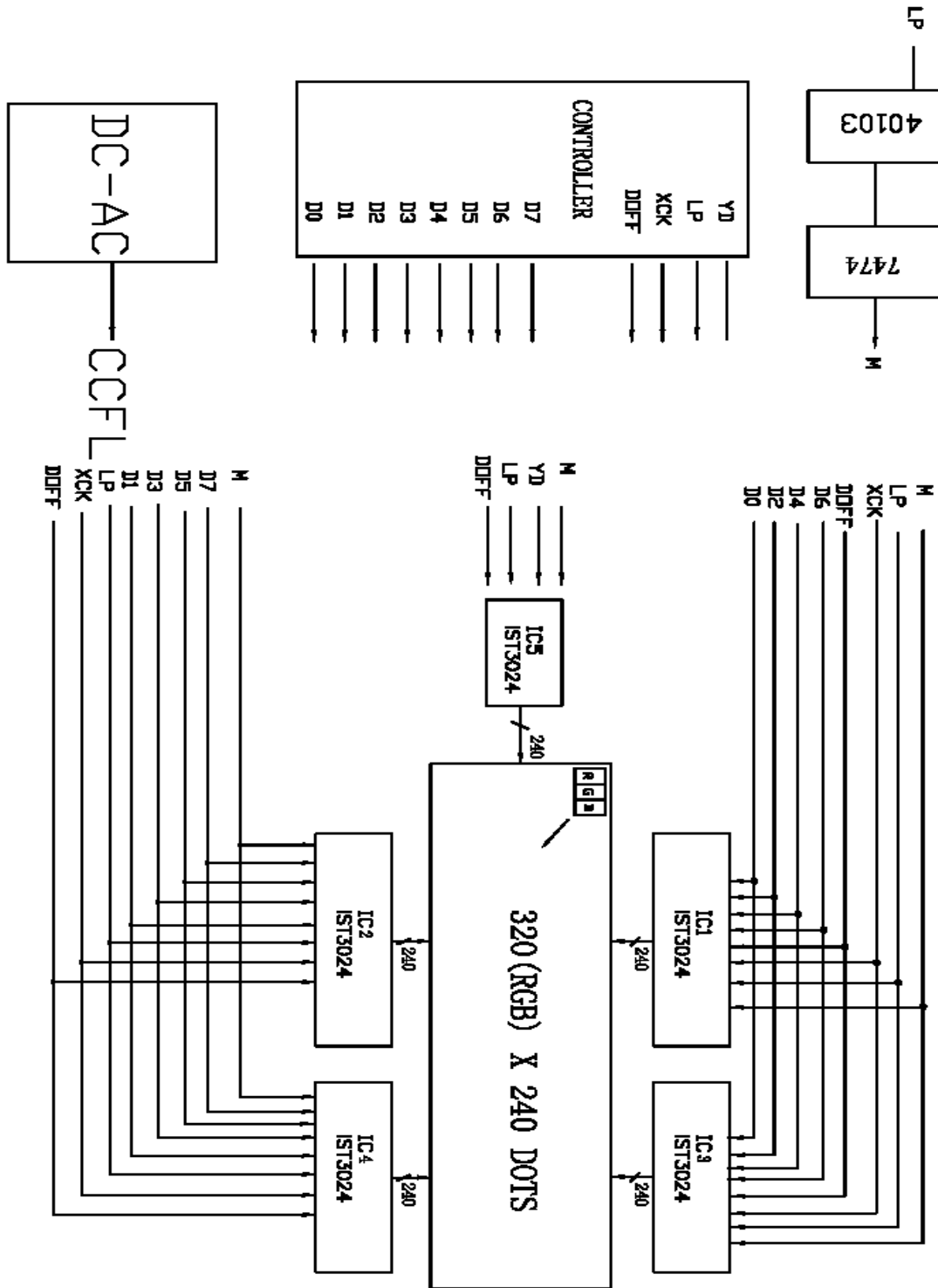



8. ELECTRO-OPTICAL CHARACTERISTICS

8.1 Optical Characteristics

$V_{LCD}=23V$ $T_a=25^{\circ}C$

Item		Symbol	Condition	Min.	Typ.	Max.	Unit
Viewing Angle	θ_x	$Cr \geq 2$	$\theta_y = 0^{\circ}$	-50 -- +40			Deg
	θ_y		$\theta_x = 0^{\circ}$	-40 -- +40			
Contrast Ratio		Cr	$\theta_x = 0^{\circ}$ $\theta_y = 0^{\circ}$	-	50	-	
Response Time	Turn on	T_{on}	$\theta_x = 0^{\circ}$ $\theta_y = 0^{\circ}$	-	150	-	ms
	Turn off	T_{off}		-	150	-	
Color Of CIE Coordinate	Red	Y	$\theta_x = 0^{\circ}$ $\theta_y = 0^{\circ}$	-	TBD	-	cd/m^2
		x		-	TBD	-	
		y		-	TBD	-	
	Green	Y	$\theta_x = 0^{\circ}$ $\theta_y = 0^{\circ}$	-	TBD	-	cd/m^2
		x		-	TBD	-	
		y		-	TBD	-	
	Blue	Y	$\theta_x = 0^{\circ}$ $\theta_y = 0^{\circ}$	-	TBD	-	cd/m^2
		x		-	TBD	-	
		y		-	TBD	-	

8.2 Definition of Optical Characteristics

8.2.1 Definition of Viewing Angle

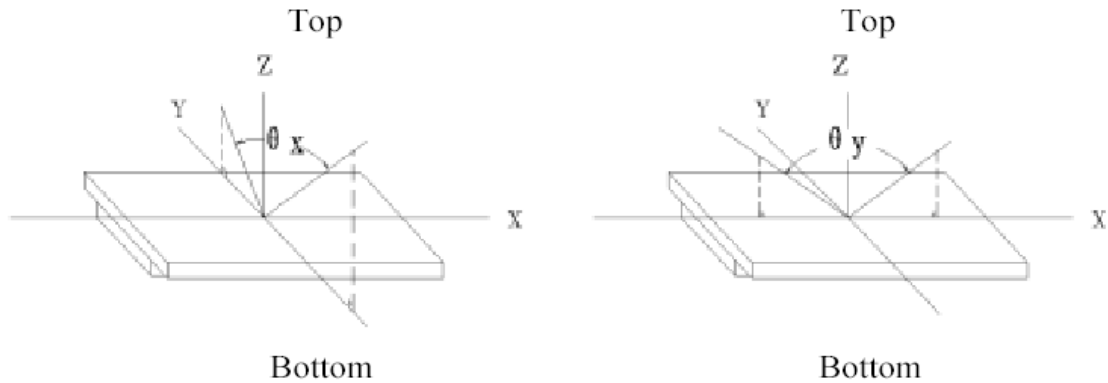

8.2.2 Definition of Contrast Ratio

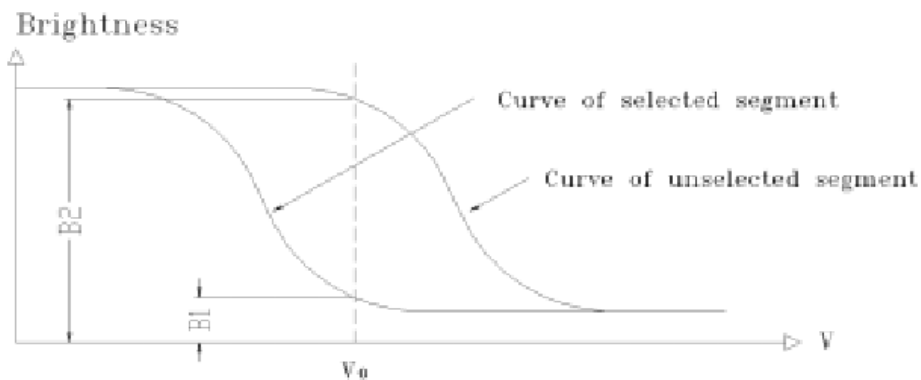

$$\text{Contrast Ratio} = B2/B1 = \frac{\text{unselected state brightness}}{\text{selected state brightness}}$$

Measuring Conditions:

- 1) Ambient Temperature: 25°C ;
- 2) Frame frequency: 64Hz

8.2.3 Definition of Response time

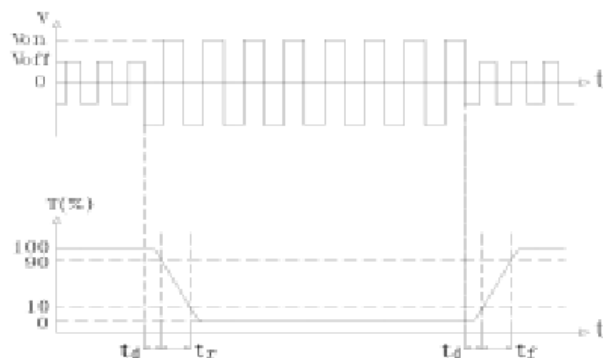

Turn on time: $t_{on} = t_d + t_r$ Turn off time: $t_{off} = t_d + t_r$

Measuring Condition:

- 1) Operating Voltage: 23.0V
- 2) Frame frequency: 64Hz

8.3 Brightness Characteristic

Item	Symbol	Condition	Min.	Typ.	Max.	Unit
Brightness	Bp	Ta=25°C±3°C	58.9	-	79.2	cd/m ²
Uniformity	ΔBp	30-80%RH	-	75	-	%

Note:

1. The data is measured after CCFLs are turned on for 5 minutes.
2. Testing conditions CCFL: V_{CF} = 270 V (AC)
 LCD: All dots are on (White color)
3. Brightness in the center of the LCD panel.
4. Definition of Uniformity (ΔBp)

$$\Delta Bp = Bp \text{ (Min.)} / Bp \text{ (Max.)} \times 100 \text{ (\%)}$$
 Bp (Max.) = Maximum brightness in 9 measurement spots
 Bp (Min.) = Minimum brightness in 9 measurement spots

9. RELIABILITY

9.1. MTBF

The LCD module shall be designed to meet a minimum MTBF value of 50000 hours with normal. (25°C in the room without sunlight)

9.2. TESTS

NO.	ITEM	CONDITION	CRITERION
1	High Temperature Operating	60 240Hrs Restore 4Hrs at 24	<ul style="list-style-type: none"> o No Defect Of Operational Function In Room Temperature Are Allowable. o IDD of LCM in Pre-and post-test should follow specification
2	Low Temperature Operating	-10 240Hrs Restore 4Hrs at 24	
3	High Temperature Storage	70 240Hrs Restore 4Hrs at 24	
4	Low Temperature Storage	-20 240Hrs Restore 4Hrs at 24	
5	High Temperature/ Humidity Storage	60 ,90%RH ,240 Hrs Restore 4Hrs at 24	
6	Temperature Cycling	-20 (30Min)↔ 70 (30Min) 10 CYCLES Restore 4Hrs at 24	
7	Vibration Test	10Hz ~ 150Hz ~ 10Hz Swing: 0.75mm	
8	Chock Test	Half-Sine Ware 300m/s ² 18ms	
9	Atmospheric Pressure Test	25Kpa 16Hrs Restore 2Hrs	

10. PRECAUTIONS FOR USING LCD MODULES

10.1. HANDLING PRECAUTIONS

- (1) The display panel is made of glass. Do not subject it to a mechanical shock or impact by dropping it.
- (2) If the display panel is damaged and the liquid crystal substance leaks out, be sure not to get any in your mouth. If the substance contacts your skin or clothes, wash it off using soap and water.
- (3) Do not apply excessive force to the display surface or the adjoining areas since this may cause the color tone to vary.
- (4) The polarizer covering the display surface of the LCD module is soft and easily scratched. Handle this polarizer carefully.
- (5) If the display surface becomes contaminated, breathe on the surface and gently wipe it with a soft dry cloth. If it is heavily contaminated, moisten a cloth with one of the following solvents:
 - Isopropyl alcohol
 - Ethyl alcohol
- (6) Solvents other than those above mentioned may damage the polarizer.
Especially, do not use the following:
 - Water
 - Ketone
 - Aromatic solvents
- (7) Extra care to minimize corrosion of the electrode. Water droplets, moisture condensation or a current flow in a high-humidity environment accelerates corrosion of the electrode.
- (8) Install the LCD Module by using the mounting holes. When mounting the LCD Module, make sure it is free of twisting, warping and distortion. In particular, do not forcibly pull or bend the I/O cable or the backlight cable.
- (9) Do not attempt to disassemble or process the LCD Module.
- (10) NC terminal should be open. Do not connect anything.
- (11) If the logic circuit power is off, do not apply the input signals.
- (12) To prevent destruction of the elements by static electricity, be careful to maintain an optimum work environment.
 - Be sure to ground the body when handling the LCD Module.
 - Tools required for assembling, such as soldering irons, must be properly grounded.
 - To reduce the amount of static electricity generated, do not conduct assembling and other work under dry conditions.

-The LCD Module is coated with a film to protect the display surface. Exercise care when peeling off this protective film since static electricity may be generated.

10.2. STORAGE CONDITIONS

When storing, avoid the LCD module to be exposed to direct sunlight of fluorescent lamps. For stability, to keep it away from high temperature and high humidity environment (The best condition is : $23\pm 5^{\circ}\text{C}$, $45\pm 20\% \text{RH}$). ESD protection is necessary for long-term storage also.

10.3. OTHERS

Liquid crystals solidify under low temperature (below the storage temperature range) leading to defective orientation or the generation of air bubbles (black or white). Air bubbles may also be generated if the module is subject to a low temperature.

If the LCD Module have been operating for a long time showing the same display patterns the display patterns may remain on the screen as ghost images and a slight contrast irregularity may also appear. A normal operating status can be recovered by suspending use for some time. It should be noted that this phenomenon does not adversely affect performance reliability.

To minimize the performance degradation of the LCD Module resulting from destruction caused by static electricity etc. exercise care to avoid holding the following sections when handling the modules.

- Exposed area of the printed circuit board.
- Terminal electrode sections.

11. Using LCD modules

11.1 LIQUID CRYSTAL DISPLAY MODULES

LCD is composed of glass and polarizer. Pay attention to the following items when handling.

- (1) Please keep the temperature within specified range for use and storage. Polarization degradation, bubble generation or polarizer peel-off may occur with high temperature and high humidity.
- (2) Do not touch, push or rub the exposed polarizers with anything harder than a HB pencil lead (glass, tweezers, etc).
- (3) N-hexane is recommended for cleaning the adhesives used to attach front/rear polarizers and reflectors made of organic substances, which will be damaged by chemicals such as acetone, toluene, toluene, ethanol and isopropyl alcohol.
- (4) When the display surface becomes dusty, wipe gently with absorbent cotton or other soft material like chamois soaked in petroleum ether. Do not scrub hard to avoid damaging the display surface.
- (5) Wipe off saliva or water drops immediately, contact with water over a long period of time may cause deformation or color fading.
- (6) Avoid contacting oil and fats.
- (7) Condensation on the surface and contact with terminals due to cold will damage, stain or polarizers. After products are tested at low temperature they must be warmed up in a container before coming is contacting with room temperature air.
- (8) Do not put or attach anything on the display area to avoid leaving marks on.
- (9) Do not touch the display with bare hands. This will stain the display area and degrade insulation between terminals (some cosmetics are determinate to the polarizers).
- (10) As glass is fragile, it tends to become or chipped during handling especially on the edges. Please avoid dropping or jarring.

11.2 INSTALLING LCD MODULE

Attend to the following items when installing the LCM.

- (1) Cover the surface with a transparent protective plate to protect the polarizer and LC cell.
- (2) When assembling the LCM into other equipment, the spacer to the bit between the LCM and the fitting plate should have enough height to avoid causing stress to the module surface, refer to the individual specifications for measurements. The measurement tolerance should be ± 0.1 mm.

11.3 ELECTRO-STATIC DISCHARGE CONTROL

Since this module uses a CMOS LSI, the same careful attention should be paid for electrostatic discharge as for an ordinary CMOS IC.

- (1) Make certain that you are grounded when handling LCM.
- (2) Before removing LCM from its packing case or incorporating it into a set, be sure the module and your body have the same electric potential.
- (3) When soldering the terminal of LCM, make certain the AC power source for the soldering iron does not leak.
- (4) When using an electric screwdriver to attach LCM, the screwdriver should be of ground potentiality to minimize as much as possible any transmission of electromagnetic waves produced sparks coming from the commutator of the motor.
- (5) As far as possible, make the electric potential of your work clothes and that of the workbenches to the ground potential.
- (6) To reduce the generation of electro-static discharge, be careful that the air in the work is not too dried. A relative humidity of 50%-60% is recommended.

11.4 PRECAUTIONS FOR OPERATION

- (1) Viewing angle varies with the change of liquid crystal driving voltage (V_o). Adjust V_o to show the best contrast.
- (2) Driving the LCD in the voltage above the limit will shorten its lifetime.
- (3) Response time is greatly delayed at temperature below the operating temperature range. However, this does not mean the LCD will be out of the order. It will recover when it returns to the specified temperature range.
- (4) If the display area is pushed hard during operation, the display will become abnormal. However, it will return to normal if it is turned off and then on.
- (5) Condensation on terminals can cause an electrochemical reaction disrupting the terminal circuit. Therefore, this product must be used and stored within the specified condition of $23\pm 5^{\circ}\text{C}$, $45\pm 20\% \text{RH}$.
- (6) When turning the power on, input each signal after the positive/negative voltage becomes stable.

11.5 SAFETY

- (1) It is recommended to crush damaged or unnecessary LCDs into pieces and wash them off with solvents such as acetone and ethanol, which should later be burned.
- (2) If any liquid leaks out of a damaged glass cell and comes in contact with the hands, wash off thoroughly with soap and water.

12. REVISION HISTORY

Version	Revise record	Date
1.0	Original version	05-07-20
2.0	Change specification format	05-11-21

SAMPLE APPROVED REPORT (样品确认单)

SAMPLE MODEL NO. (样品型号)	GC5007
SAMPLE SERIES NUMBER NO. (样品序号)	
SAMPLE QUANTITY (样品数量)	
COLOR/TYPE (底色/类型)	C-STN/NEGATIVE
VIEWING DIRECTION (视角)	6:00
DRIVING METHOD (驱动参数)	1/240Duty, 1/17Bias
LOGIC VOLTAGE (IC 工作电压)	5.0V
LCD VOP (LCD 驱动电压)	23.0V
OPERATING TEMP. (操作温度)	-10~60
STORAGE TEMP. (储存温度)	-20~70
POLARIZER----FRONT (首偏光片)	TRANSMISSIVE
POLARIZER----BACK (后偏光片)	TRANSMISSIVE
CONTROLLER/DRIVER IC(控制/驱动 IC)	NONE/IST3024TA0
BACKLIGHT COLOR/TYPE (背光源类型/颜色)	CCFL/WHITE
DRAWING REV/NO./QUANTITY (图纸版本/数量)	
SPECIFICATION (规格书 份数)	
REMARKS : (备注)	
WRIT BY : _____ DATE : _____ APROV BY : _____ DATE : _____	
CUSTOMER'S APPROVAL (客户确认) :	
1) FUNCTION (功能) : <input type="checkbox"/> OK <input type="checkbox"/> N.G.	
2) DRIVER CONDITION (驱动条件) : <input type="checkbox"/> OK <input type="checkbox"/> N.G.	
3) DISPLAY MODE (显示模式) : <input type="checkbox"/> OK <input type="checkbox"/> N.G.	
4) VIEWING ANGLE (视角) : <input type="checkbox"/> OK <input type="checkbox"/> N.G.	
5) BACKLIGHT (背光源) : <input type="checkbox"/> OK <input type="checkbox"/> N.G.	
6) DISPLAYING PATTERN (显示效果) : <input type="checkbox"/> OK <input type="checkbox"/> N.G.	
CUSTOMER'S CONCLUSIONS (客户意见) : _____	

CUSTOMER'S SIGNATURE (客户签名) : _____ DATE (日期) : _____	