

M81511/17, M81511/18, and M81511/29 Protective Covers



Protective
Covers

MIL-C-81511

Inactive for
New Design

M81511/17-16

Basic Part No. _____ Shell Size
 M81511/17 = Plug Cover Series 2
 M81511/18 = Receptacle Cover
 Series 1 and 2
 M81511/29 = Plug Cover Series 1

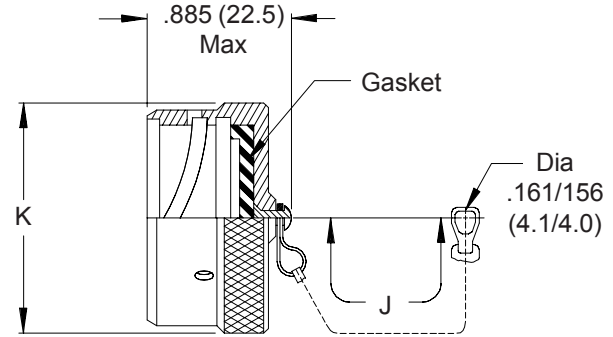
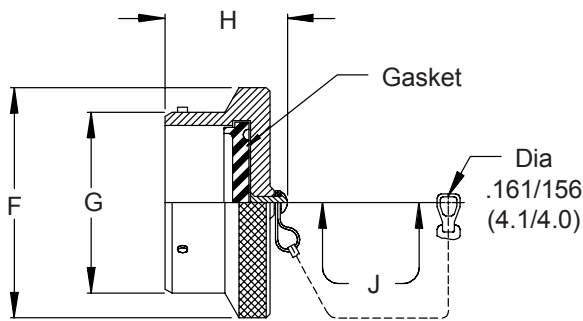

M81511/29 Plug Cover - Series 1
M81511/17 Plug Cover - Series 2

M81511/18 Receptacle Cover
Series 1 and 2

TABLE I

Shell Size	F Dia Max	G Dia		H Max		J ± One Link	K Dia Max
		+0.006 (0.2)	(0.0)	M81511/29	M81511/17		
08	.845 (21.5)	.553 (14.0)	(0.0)	1.125 (28.6)	.985 (25.0)	3.0 (76.2)	.844 (21.4)
10	.970 (24.6)	.678 (17.2)	(0.2)	1.125 (28.6)	.985 (25.0)	3.0 (76.2)	.969 (24.6)
14	1.220 (31.0)	.928 (23.6)		1.125 (28.6)	.985 (25.0)	3.5 (88.9)	1.219 (31.0)
16	1.345 (34.2)	1.054 (26.8)		1.125 (28.6)	.985 (25.0)	3.5 (88.9)	1.345 (34.2)
18	1.470 (37.3)	1.178 (29.9)		1.125 (28.6)	.985 (25.0)	3.5 (88.9)	1.469 (37.3)
20*	1.595 (40.5)	1.303 (33.1)		1.125 (28.6)		3.5 (88.9)	1.594 (40.5)
22*	1.720 (43.7)	1.428 (36.3)		1.125 (28.6)		3.5 (88.9)	1.719 (43.7)
24*	1.845 (46.9)	1.553 (39.4)		1.125 (28.6)		3.5 (88.9)	1.844 (46.8)

* Not Applicable for M81511/17 or M81511/18

1. For complete dimensions see applicable Military Specification.
2. Metric dimensions (mm) are indicated in parentheses.