

#### AC High Performance Fans

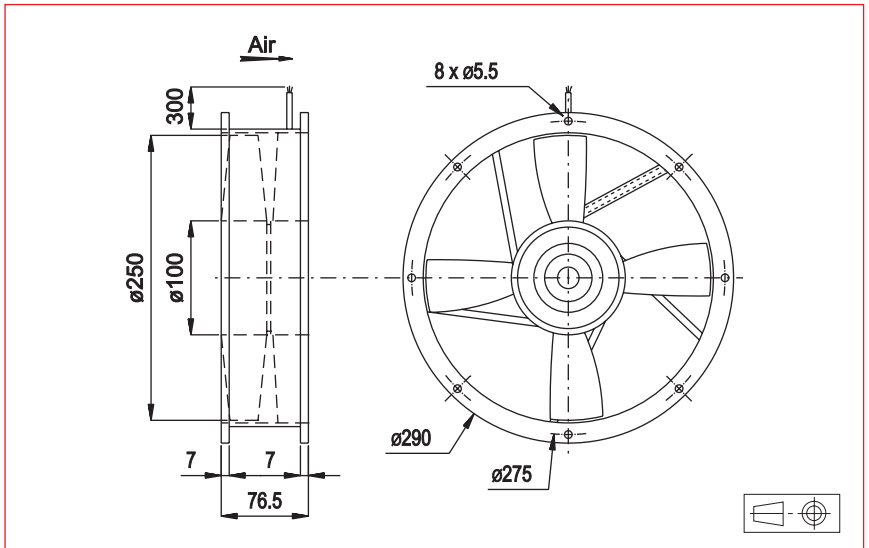

#### Approvals

CE, NATO codification

#### Life expectancy

L-10 LIFE AT 40°C:  
25 000 hours

#### AC Motor

Housing material: aluminium  
Impeller material: plastic  
Weight: 2,9 kg  
Bearing system: ball bearings

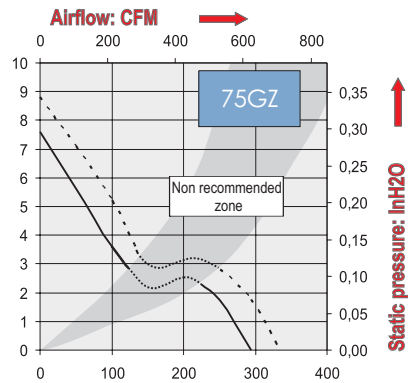
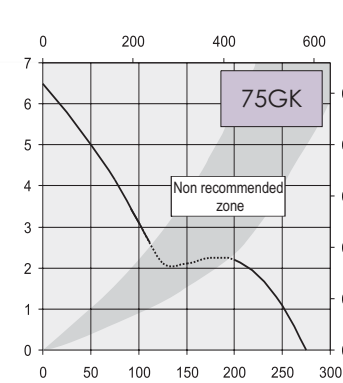
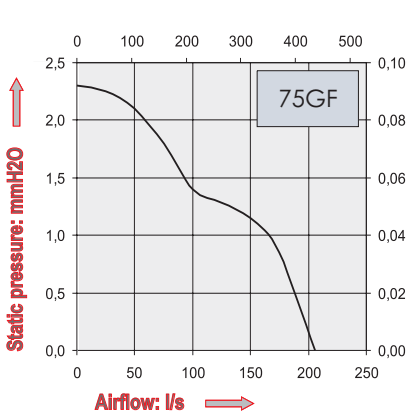

Part Number	Nominal voltage	Airflow	Noise level	Nominal speed	Frequency	Phases	Capacitor (not included)	Input power	Nominal Current	Starting Current	Connection type		Operating temperature	
	V	l/s	dB(A)	RPM	Hz		µF	W	mA	mA	Leads	Terminals	Min.°C	Max.°C
75GF026AC11	110	206	45	1000	50	1		28	370	470	X		-10	55
	220	206	45	1000	50	1		28	185	235	X		-10	55
75GK026AC11	110	275	54	1350	50	1		41	610	1150	X		-10	55
	220	275	54	1350	50	1		41	305	575	X		-10	55
75GZ026DC13	220	290	55	1400	50	3		38	155	385	X		-10	70
	380	290	55	1400	50	3		38	90	225	X		-10	70
	220	330	58	1600	60	3		40	145	355	X		-10	70
	380	330	58	1600	60	3		40	85	210	X		-10	70
	220	290	55	1400	50	1	2,2	34	165	330	X		-10	70
	380	290	55	1400	50	1	0,69	34	100	200	X		-10	70
	220	320	58	1600	60	1	2,2	42	210	320	X		-10	70
	380	320	58	1600	60	1	0,69	42	125	190	X		-10	70

#### Additional versions:

Salt spray protected - Shock and vibration protected - Marine specifications  
Wide temperature range - Other voltages (consult factory)

#### Accessories:

Refer to Accessories leaflet