



## Features

- Max. 11,000 counts resolution
- Conversion rate selectable by MPU command: 1.6/s → 128/s
- Input signal full scale: 110mV
- 50/60Hz line noise rejection selectable by MPU command
- Low battery detection
- Multiple input channels for ADC
- 3-wire serial bus and EOC signal for MPU I/O port
- -3V power operation with internal charge pumping circuit
- MPU I/O power level selectable by external control pin
- Zero calibration for eliminating offset error
- On-chip buzzer driving and frequency selectable by MPU command
- Support sleep mode by external CS(chip-select) pin

## Application

Clamp meter

Thermometer

Portable instrumentation

## Description

ES51992 is an 11000-count dual-slope analog-to-digital converter (ADC). The conversion rate and buzzer frequency can be selected or decided by an external microprocessor. The conversion rate can be varied from 1.6 time/sec to 128 times/sec under 4MHz/12MHz crystal oscillation clock. Besides, ES51992 also provides multi-channels input, low battery detection, power-down mode, 50/60Hz line noise rejection selection, and I/O port level selection for flexible design.



**Pin Assignment**

LQFP-32L

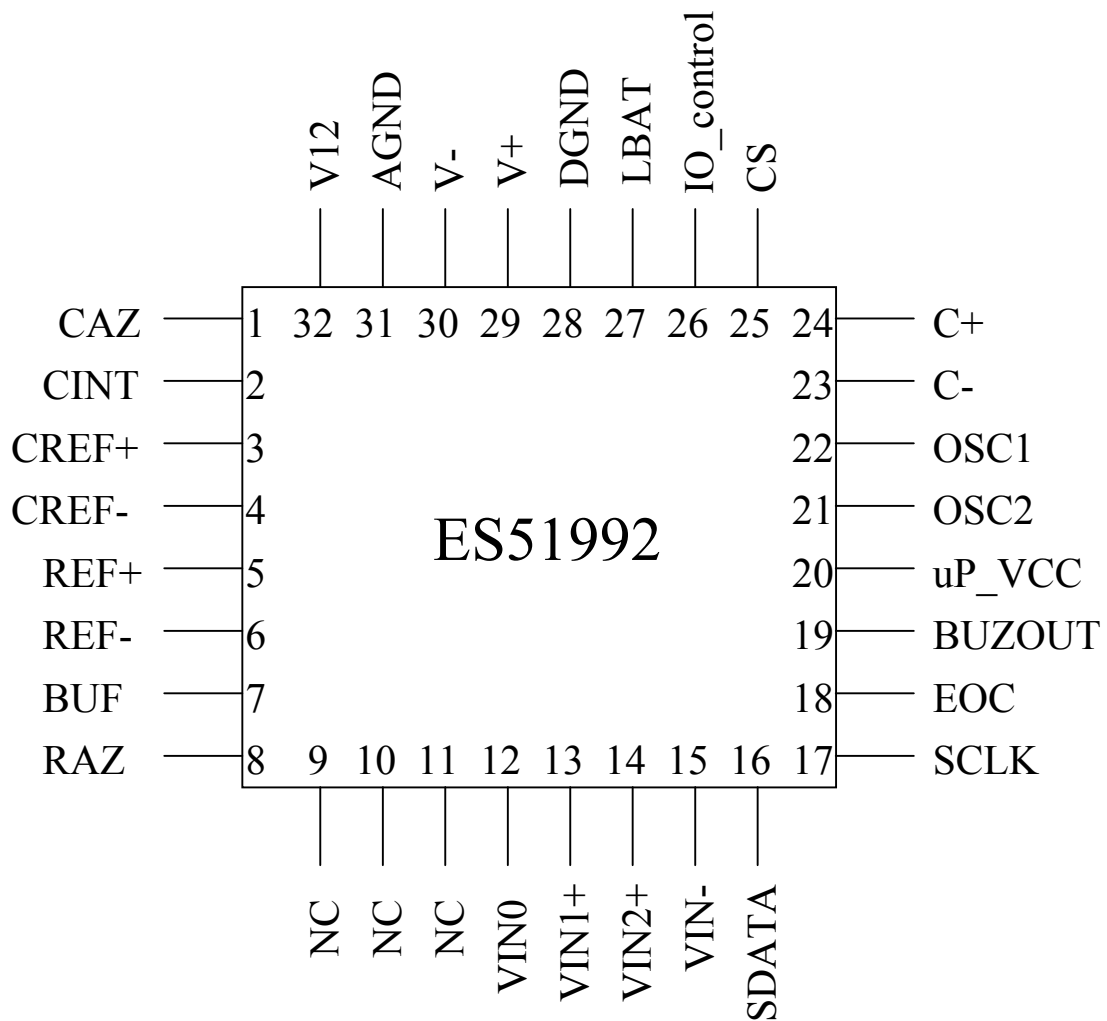



### Pin Description

Pin No	Symbol	Type	Description
1	CAZ	I	Auto-zero capacitor connection.
2	CINT	O	Integrator output. Connect to integral capacitor
3	CREF+	I/O	Positive connection for reference capacitor.
4	CREF-	I/O	Negative connection for reference capacitor.
5	REF+	I	Differential reference high voltage input.
6	REF-	I	Differential reference low voltage input.
7	BUF	O	Buffer output pin. Connect to integral resistor
8	RAZ	O	Buffer output pin in high-speed mode. Connect to high-speed integral resistor.
9	NC	-	Not connected
10	NC	-	Not connected
11	NC	-	Not connected
12	VIN+	I	Analog differential high signal input.
13	VIN1+	I	Analog signal high input1
14	VIN2+	I	Analog signal high input2
15	VIN-	I	Analog differential low signal input.
16	SDATA	I/O	Serial data I/O pin. Nch open-drain output.
17	SCLK	I	Serial clock input pin.
18	EOC	O	An indicator for ADC conversion ending.
19	BUZout	O	Buzzer frequency output
20	uP_VCC	I	MPU I/O port power level selection
21	OSC2	O	Crystal oscillation connection
22	OSC1	I	Crystal oscillation connection
23	C-	O	Negative capacitor connection for on-chip DC-DC converter.
24	C+	O	Positive capacitor connection for on-chip DC-DC converter.
25	CS	I	Chip select input pin. Pull to Low to enter power down mode.
26	I/O_control	I	MPU I/O port ground level selection
27	LBAT	I	Low battery configuration. If 3V battery is used, connect it to AGND. The default low-battery threshold voltage is -2.3V. If 9V or other battery voltage is used, the low battery annunciator is displayed when the voltage of this pin is less than V12
28	DGND	G	Digital ground
29	V+	O/P	Output of on-chip DC-DC converter.
30	V-	P	Negative supply voltage. Connecting to 3V battery negative terminal.
31	AGND	G	Analog ground
32	V12	O	Output of band-gap voltage reference. Typically -1.23V



## Function description

### 1. Dual Slope A/D—Four Phases Timing

ES51992 is a dual-slope analog-to-digital converter (ADC). Figure 1 is a structure of dual-slope integrator. Its measurement cycle has two distinct phases: input signal integration (INT) phase and reference voltage integration (DINT) phase.

In INT phase, the input signal is integrated for a fixed time period, then A/D enters DINT phase in which an opposite polarity constant reference voltage is integrated until the integrator output voltage becomes to zero. Since both the time period for input signal integration and the amount of reference voltage are fixed, thus the de-integration time is proportional to the input signal. Hence, we can define the mathematical equation about input signal, reference voltage integration (see Figure 1.):

$$\frac{1}{Buf \times C_{int}} \int_0^{T_{INT}} V_{IN}(t) dt = \frac{1}{Buf \times C_{int}} \times V_{REF} \times T_{DINT}$$

where,  $V_{IN}(t)$  = input signal

$V_{REF}$  = reference voltage

$T_{INT}$  = integration time (fixed)

$T_{DINT}$  = de-integration time (proportional to  $V_{IN}(t)$ )

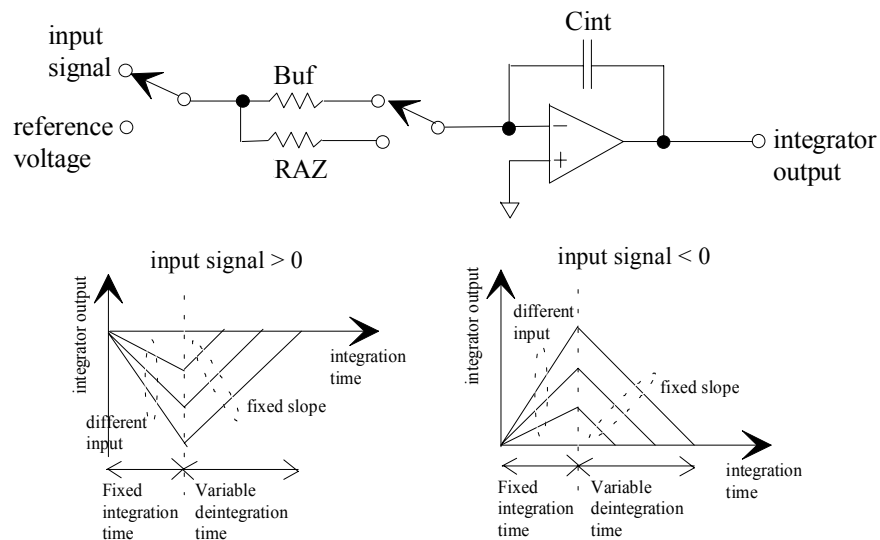

Figure 1. the structure of dual-slope integrator and its output waveform.

If  $V_{IN}(t)$  is a constant, we can rewrite above equation:

$$T_{DINT} = \frac{T_{INT}}{V_{REF}} \times V_{IN}$$



Besides the INT phase and DINT phase, ES51992 exploits auto zero (AZ) phase and zero integration (ZI) phase to achieve accurate measurement. In AZ phase, the system offset is stored. The offset error will be eliminated in DINT phase. Thus a higher accuracy could be obtained. In ZI phase, the internal status will be recovered quickly to that of zero input. Thus the succeeding measurements won't be disturbed by current measurement especially in case of overload.

As mentioned above, the measurement cycle of ES51992 contains four phases:

- (1) auto zero phase (AZ)
- (2) input signal integration phase (INT)
- (3) reference voltage integration phase (DINT)
- (4) zero integration phase (ZI)

The time ratios of these four phases, AZ, INT, DINT and ZI to the entire measurement cycle are 8.8%, 32%, 35.2% and 24% respectively. However the actual duration of each phase depends on conversion rate. An example is shown in the table below. A user can easily deduce other cases based on the table.

Voltage:

CR (times/sec)	ZI (ms)	AZ (ms)	INT (ms)	DINT (ms)
<b>8</b>	<b>30</b>	<b>11</b>	<b>40</b>	<b>44</b>

Note: reference voltage = -100 mV.

Voltge+PEAK:

CR (times/sec)	ZI (ms)	AZ (ms)	INT (ms)	DINT (ms)
<b>8</b>	<b>30</b>	<b>11</b>	<b>40</b>	<b>60</b>

Note: reference voltage = -100 mV.



## 2. Component Value Selection for ADC

For various application requirements on conversion rate and input full range, we suggest nominal values for external components of ADC in Figure 1 to obtain better performance. Under default condition with operating clock = 12 MHz:

- (1) conversion rate = 8 times/sec
- (2) reference voltage = -100 mV
- (3) input signal full scale = 110 mV (sensitivity = 10 uV)

We suggest that  $C_{int} = 68 \text{ nF}$ ,  $B_{uf} = 56 \text{ k}\Omega$

If a user selects a different conversion rate rather than default, the integration capacitor  $C_{int}$  value must be changed according to the following rule for better performance:

$$C_{int} \times (\text{conversion rate}) = (68 \text{ nF}) \times (8 \text{ times/sec}).$$

A smaller  $C_{int}$  reduces the input full range. However a larger  $C_{int}$  might have weaker noise immunity than the suggested one.

A user could enlarge the input full range by changing reference voltage ( $V_{ref}$ ) and the amount of integration resistor ( $B_{uf}$ ). For example, if  $V_{ref}$  &  $B_{uf}$  are enlarged as twice than the default values then the input full range becomes 220 mV. The input full range can be enlarged up to 1.1V (10 times than the default case). We list general rules in below which might be helpful in determining component values.

$$B_{uf} / (\text{reference voltage}) = 56 \text{ k}\Omega / (-100 \text{ mV})$$



### 3. Multi Channel Input

ES51992 provides VIN+, VIN1+, VIN2+ and Vin- pins to achieve the multi channel input (multiplexer) feature. Because ES51992 is a single core A-to-D converter, it can only process one pack of data per conversion period. Although it has four input pins, it would take only one pair as input channel from the four pins. The actual input channel is determined by the bits CH1/CH0 of STATUS Byte1 as the following table:

Input Channel	CH1	CH0	High Input	Low Input
ch1	0	0	VIN+	VIN-
ch2	0	1	VIN1+	VIN-
ch3	1	0	VIN2+	VIN-
ch4	1	1	VIN2+	VIN1+

ES51992 also configures an input channel rotation (polling) feature. The rotation feature can be activated by setting the ROT bit of STATUS Byte2 to high. In the rotation mode, the actual input channel will be changed by ES51992 sequentially and automatically. The rotation feature has two types, one is for three input channel rotation with the same low input, another one is for two independent differential channel rotation. The following table presents the configuration of the rotation type.

Rotation Type Table:

ROT	CH1,CH0	Rotation Type
H	0,0	ch1 → ch2 → ch3 → ch1 ...
	0,1	
	1,0	
	1,1	ch1 → ch4 → ch1 ...
L	-	Not Rotating



## 4. Special function

### 4.1 Zero and RZero Calibration

The Zero and RZero calibration are designed for removing the error rise from the propagation delay of internal component. In Zero or RZero calibration mode, ES51992 outputs a calibration value. The normal measurement value must minus the calibration value to cancel the error and obtain a more accurate value. The following block diagram performs the difference between basic structures of normal mode, Zero calibration and RZero Calibration. We suggest users to do zero-calibration in most applications.

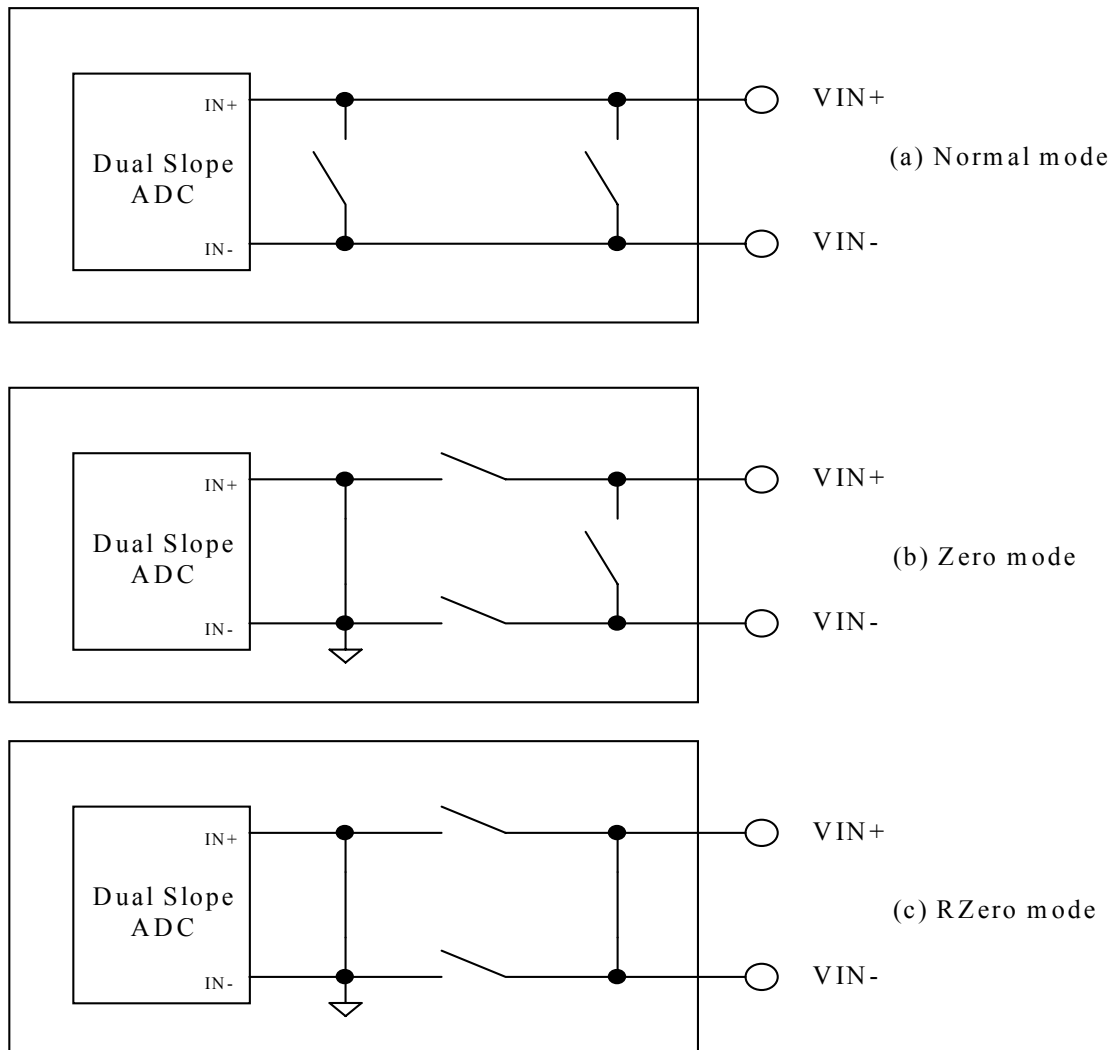



## 4.2 Buzzer Setup

When the bit **BUZ** of ID Byte is set to “H”, the BUZOUT will output a square signal of MPU I/O swing level to drive a external buzzer. The buzzer frequency is determined by the bits B0/B1/B2 of STATUS Byte3. The configuration of buzzer frequency is listed at the following table.

B2/B1/B0	BUZout (kHz)
111	4.00
110	3.33
101	3.08
100	2.67
011	2.22
010	2.00
001	1.33
000	1.00

## 4.3 Low Battery Detection

In a case of 3V battery power, the pin LBAT must be shorted to AGND. And the system will have low battery detection level about 2.3V. In another case of 9V or other battery power, the low battery detection happens when the voltage of LBAT is less than  $-1.23V$  below GND. And the bit LBAT of STATUS Byte3 will be set to high. A recommended application is shown as following:

### Low battery test (9V)

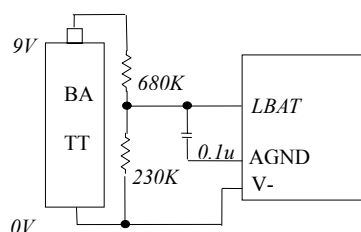

The low battery detection level is around 7V

## 4.4 Sleep Mode

When the pin CS is connected to V- or GND (depended on I/O\_control level), the ES51992 will enter sleep mode. In Sleep mode, the chip draws a little supply current. It could extend the battery life. To leave sleep mode or stay in normal mode, the pin CS must be connected to AGND or floating.



## 5. MPU I/O function definition

### Write command:

ID byte, Status byte1, Status byte2, Status byte3

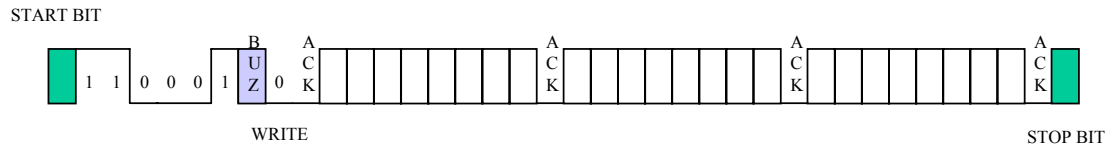

### Read command:

ID byte, Status byte1, Status byte2, Status byte3, Data byte1, Data byte2

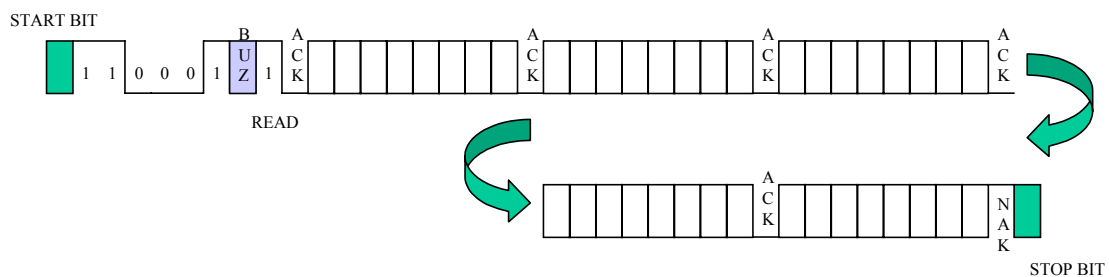

### Start and Stop bit

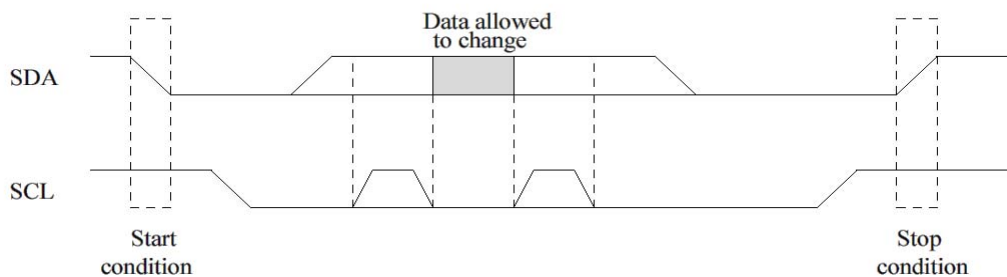

ID byte:

1	1	0	0	0	1	BUZ	R/W
---	---	---	---	---	---	-----	-----

Status byte1:

CH0	CH1	C0	C1	C2	SIGN	SEL4M	X
-----	-----	----	----	----	------	-------	---

Status byte2:

S60	RZERO	ZERO	ROT	X	X	X	X
-----	-------	------	-----	---	---	---	---

Status byte3:

0	0	B0	B1	B2	LBAT	X	X
---	---	----	----	----	------	---	---

Data byte1:

D0	D1	D2	D3	D4	D5	D6	D7
----	----	----	----	----	----	----	----

Data byte2:

D8	D9	D10	D11	D12	D13	X	X
----	----	-----	-----	-----	-----	---	---



**R/W:** set to “H” is in read mode, set to “L” is in write mode

**CH1/CH0:** ADC input channel selection, the default is [00].

Code	VIN(+)	VIN(-)
00	VIN0 channel	VIN- channel
01	VIN1 channel	VIN- channel
10	VIN2 channel	VIN- channel
11	VIN2 channel	VIN1 channel

**C2/C1/C0/S60:** Conversion rate selection, the default is [0000]

C2/C1/C0	S60	
	L	H
101	128/s	128/s
100	96/s	96/s
011	64/s	76.8/s
010	32/s	38.4/s
001	16/s <sup>!</sup>	19.2/s <sup>*</sup>
000	8/s <sup>!</sup>	9.6/s <sup>*</sup>
110	3.2/s <sup>*</sup>	3.84/s <sup>*</sup>
111	1.6/s <sup>*</sup>	1.92/s <sup>*</sup>

Crystal: 12MHz

!: 50Hz line noise rejection, \*: 60Hz line noise rejection

**SEL4M:** “H” is XTAL is 4MHz version, “L” is default 12MHz XTAL

C2/C1/C0	S60
	X
101	128/s
100	64/s
011	64/s
010	32/s
001	16/s <sup>!</sup>
000	8/s <sup>!</sup>
110	3.2/s <sup>!*</sup>
111	1.6/s <sup>!*</sup>

Crystal :4MHz

**SIGN:** “H” is negative, “L” is positive

**LBAT:** “H” is low battery detection flag active, the default is “L”

**RZERO:** “H” is RZero calibration mode “ON”, the default is “L”

**ZERO:** “H” is Zero calibration mode “ON”, the default is “L”

**ROT:** Set to ”H” to enable multi channel rotating feature

**B2/B1/B0:** Buzzer frequency selection (independent with conversion rate)

**BUZ:** “H” is buzzer turn on and “L” is turn off, the default is turn off.



Buzzer ON

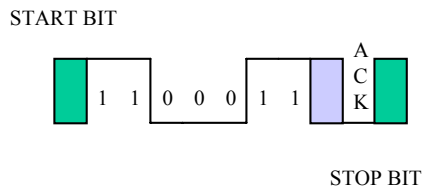

Buzzer OFF

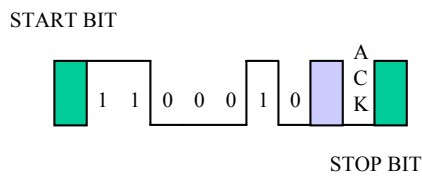

**D13-D0:** ADC output data according channel multiplex [CH1/CH0]. Binary code format.

## 6. Power and I/O output level selection

### Power

- Charge pump output for positive supply voltage(V+)
- External DC source to V+ is available by floating the charge pump capacitor

### I/O output level selectable

- uP\_VCC provided by external DC source (the same high level with MPU)
- A control pin (I/O\_control) selects the low level to -3V(V-) or 0V(DGND)

uP_VCC	I/O_control	I/O level		Example
		H	L	
3	H	+3V	0V	Ex.1
3	L	+3V	-3V	Ex.2
0	L	0V	-3V	Ex.3

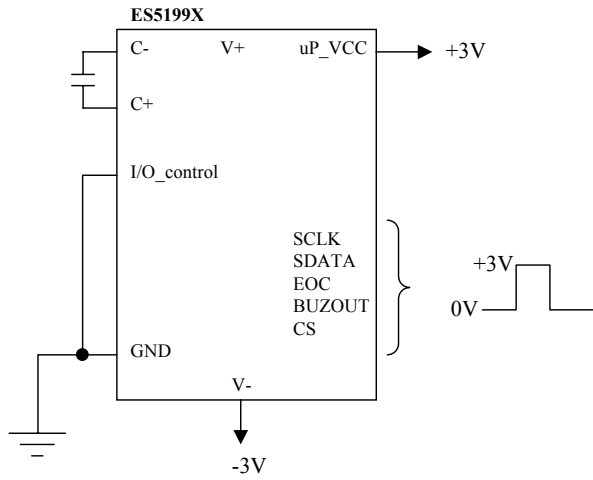

Ex.1

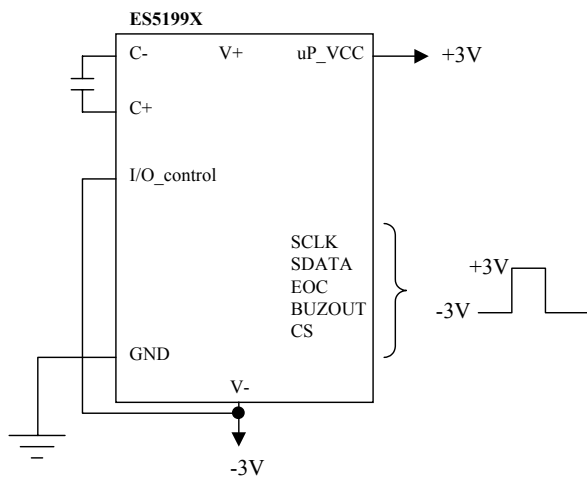

Ex.2

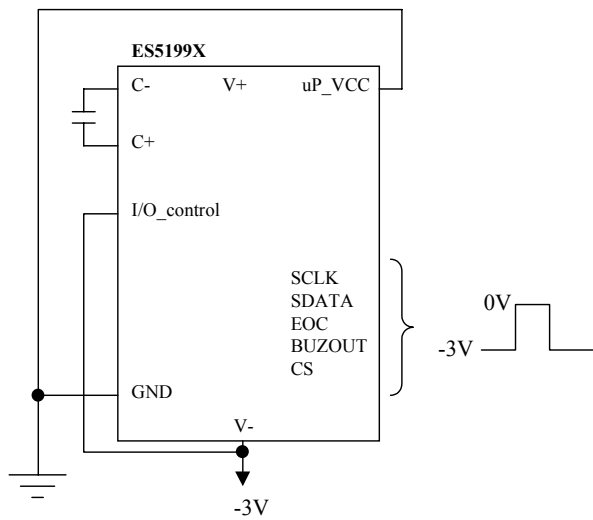

Ex.3



### Absolute Maximum Ratings

Characteristic	Rating
Supply Voltage (V- to AGND)	-3.6V
Analog Input Voltage	V- -0.6 to V+ +0.6
V+	$V+ \geq (AGND/DGND+0.5V)$
AGND/DGND	$AGND/DGND \geq (V- -0.5V)$
Digital Input	V- -0.6 to DGND +0.6 or V+ +0.6
Power Dissipation. Flat Package	500mW
Operating Temperature	0°C to 70°C
Storage Temperature	-25°C to 125°C

### DC Electrical Characteristics

TA=25°C, V<sub>CM</sub>=0V, V- = -3V

Parameter	Symbol	Test Condition	Min.	Typ.	Max	Units
Power supply	V-		-3.3	-3.0	-2.5	V
Operating supply current Conversion rate = 8/sec	I <sub>DD</sub>	Normal operation (XTAL=12MHz)	—	2.0	2.2	mA
	I <sub>SS</sub>	In sleep mode	—	2.5	5	μA
Voltage roll-over error	REV		—	—	±0.05	%F.S <sup>1</sup>
Voltage nonlinearity	NLV	Best case straight line	—	—	±0.05	%F.S
Input Leakage				1	10	pA
Low battery flag voltage		V- to AGND	-2.4	-2.3	-2.2	V
Internal pull-high to uP_Vcc current		CS (uP_Vcc=3V)		5		uA
		CS(uP_Vcc=0V)		1.5		
Internal pull-low to V- current		I/O_control (V=-3V)		1.5		uA
Zero input reading		10MΩ input resistor zero cal. by MPU	-000	000	+000	counts
Reference voltage and open circuit voltage for 110Ω measurement	V <sub>REF</sub>	100KΩ resistor between VRH and AGND	-1.33	-1.23	-1.13	V
Reference voltage temperature coefficient	TC <sub>RF</sub>	100KΩ resistor Between VRH 0°C < TA < 70°C	—	50	—	ppm/°C

Note:

1.Full Scale



**AC Electrical Characteristics**

Parameter	Symbol	Min.	Typ.	Max.	Unit
SCLK clock frequency	$f_{SCLK}$	-	-	100	kHz
SCLK clock time "L"	$t_{LOW}$	4.7	-	-	us
SCLK clock time "H"	$t_{HIGH}$	4.0	-	-	
SDATA output delay time	$t_{AA}$	0.1	-	3.5	ns
SDATA output hold time	$t_{DH}$	100	-	-	
Start condition setup time	$t_{SU,STA}$	4.7	-	-	us
Start condition hold time	$t_{HD,STA}$	4.0	-	-	
Data input setup time	$t_{SU,DAT}$	200	-	-	ns
Data input hold time	$t_{HD,DAT}$	0	-	-	
Stop condition setup time	$t_{SU,STO}$	4.7	-	-	us
SCLK/SDATA rising time	$t_R$	-	-	1.0	
SCLK/SDATA falling time	$t_F$	-	-	0.3	
Bus release time	$t_{BUF}$	4.7	-	-	
EOC setup time in read mode	$t_{SU,EOC}$	0	-	-	ns
EOC hold time in read mode	$t_{HD,EOC}$	0	-	-	ns

**I/O timing diagram**

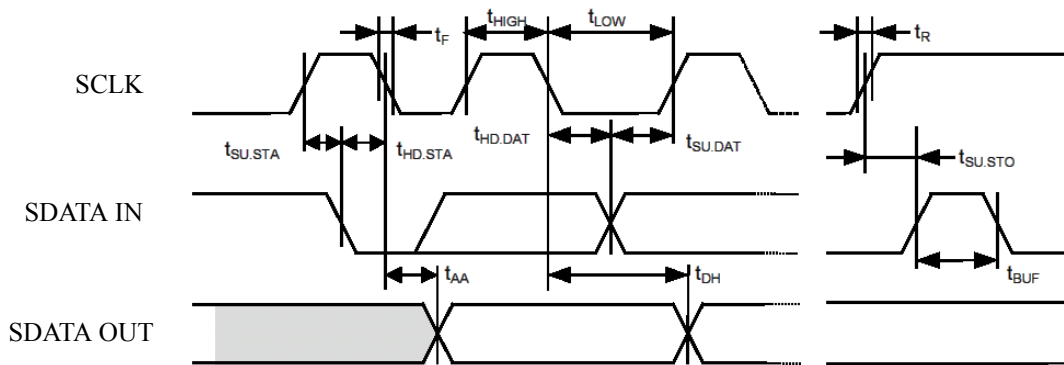

**Read mode EOC timing diagram**

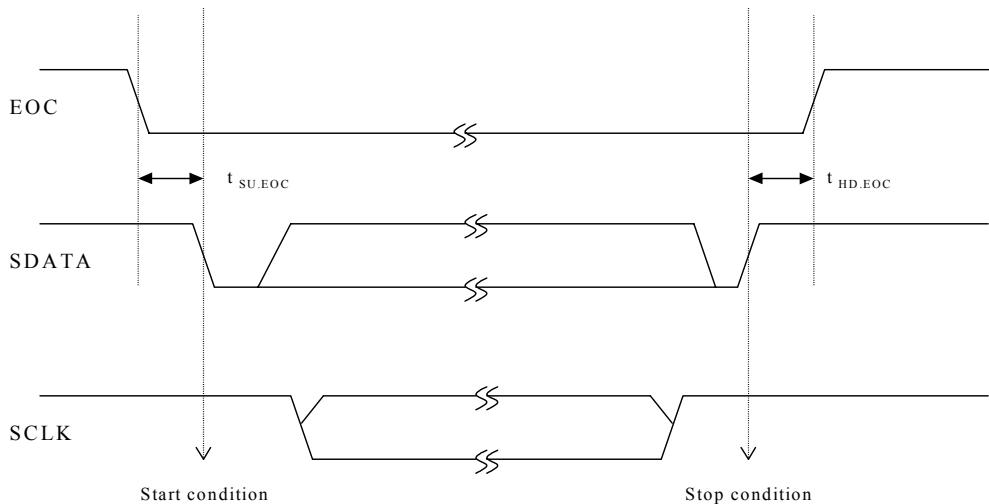







Product Outline: LQFP-32

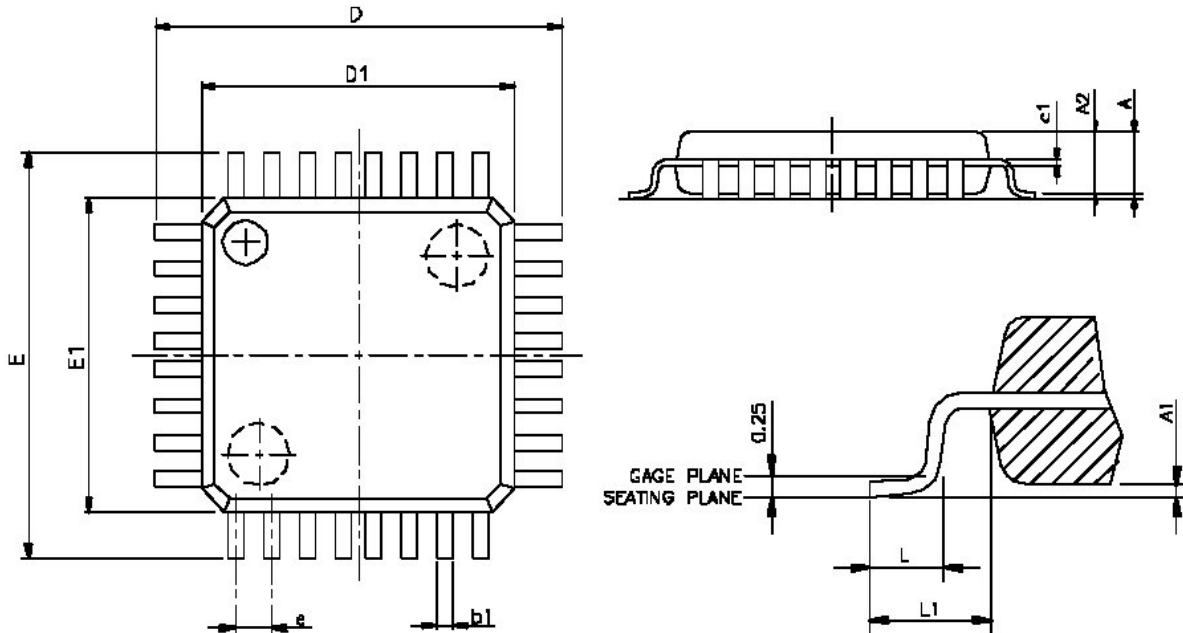

VARIATIONS (ALL DIMENSIONS SHOWN IN MM)

SYMBOLS	MIN.	MAX.
A	--	1.6
A1	0.05	0.15
A2	1.35	1.45
c1	0.09	0.16
D	9.00 BSC	
D1	7.00 BSC	
E	9.00 BSC	
E1	7.00 BSC	
e	0.8 BSC	
b	0.30	0.45
L	0.45	0.75
L1	1 REF	

NOTES:

1. JEDEC OUTLINE: MS-026 BBA
2. DIMENSIONS D1 AND E1 DO NOT INCLUDE MOLD PROTRUSION. ALLOWABLE PROTRUSION IS 0.25mm PER SIDE. D1 AND E1 ARE MAXIMUM PLASTIC BODY SIZE DIMENSIONS INCLUDING MOLD MISMATCH.
3. DIMENSION b DOES NOT INCLUDE DAMBAR PROTRUSION. ALLOWABLE DAMBAR PROTRUSION SHALL NOT CAUSE THE LEAD WIDTH TO EXCEED THE MAXIMUM b DIMENSION BY MORE THAN 0.08mm.