

Features

- Absorbive or Reflective
- Excellent Intermodulation Products
- Excellent Temperature Stability
- Fast Switching Speed: 3 nS Typical
- Ultra Low DC Power Consumption
- Independent Bias Control

Description

M/A/COM's MASW4030G is an SPDT absorbive or reflective GaAs MESFET MMIC. This part combines small size, low insertion loss and power consumption with high isolation. Ideal for many applications and module use. It will function well for designs below 4.0 GHz.

The MASW4030G is fabricated using a mature 1-micron gate length GaAs MESFET process. The process features full chip passivation for increased performance and reliability.

Ordering Information

Part Number	Package
MASW4030G	DIE

Absolute Maximum Rating^{1,2}

Parameter	Absolute Maximum
Control Value (A or B)	-8.5 Vdc
Max Input RF Power	+34.0 dBm (500 MHz - 4 GHz)
Storage Temperature	-65°C to +175°C
Max Operating Temperature	+175°C

1. Exceeding any one or combination of these limits may cause permanent damage to this device.
2. M/A-COM does not recommend sustained operation near these survivability limits.

Pad Layout

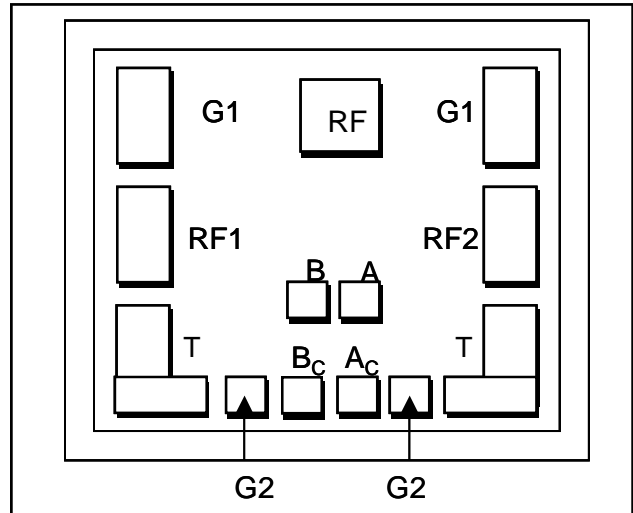

Die Size - Inches (mm)

0.042 x 0.040 x 0.010 (1.065 x 1.015 x 0.25)

Bond Pad Dimensions

Bond Pad	Dimensions - Inches (mm)
G1	0.004 x 0.008 (0.100 x 0.200)
RF1, RF2	0.004 x 0.008 (0.100 x 0.200)
T	0.0065 x 0.13 (0.165 x 0.330)
A, B, Ac, Bc, G2	0.004 x 0.004 (0.100 x 0.100)
RF	0.008 x 0.006 (0.200 x 0.150)

Schematic

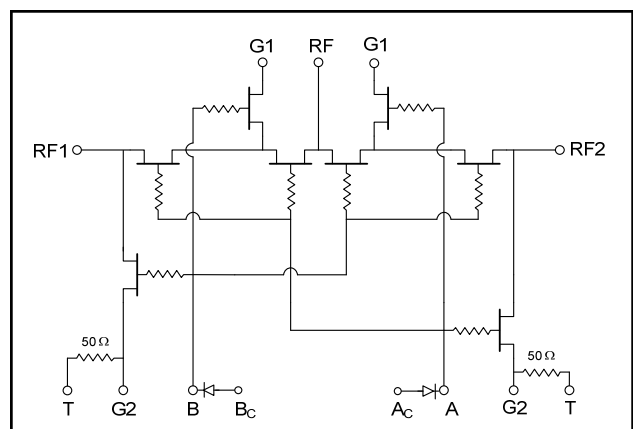

GaAs SPDT Switch DC - 4.0 GHz

Rev. V3

Electrical Specifications : $T_A = 25^\circ\text{C}$, $Z_0 = 50 \Omega$, -55°C to $+85^\circ\text{C}$

Parameter	Test Conditions	Units	Min.	Typ.	Max.
Insertion Loss	DC - 1.0 GHz	dB	—	—	0.6
	DC - 2.0 GHz	dB	—	—	0.8
	DC - 4.0 GHz	dB	—	—	1.0
Isolation	DC - 1.0 GHz	dB	60	—	—
	Absorptive Mode DC - 2.0 GHz	dB	50	—	—
	Reflective Mode DC - 2.0 GHz	dB	42	—	—
	DC - 4.0 GHz	dB	40	—	—
VSWR	DC - 1.0 GHz	Ratio	—	—	1.2:1
	DC - 2.0 GHz	Ratio	—	—	1.2:1
	DC - 4.0 GHz	Ratio	—	—	1.5:1
Input P-1dB	0.05 GHz (0 / -5 V, 0 / -8 V)	dBm	—	+24, +25	—
	0.5 - 4.0 GHz (0 / -5 V, 0 / -8 V)	dBm	—	+30, +33	—
IP2	Two Tone Input Power up to +5 dBm	dBm	—	62	—
	0.05 GHz 0.05 - 4.0 GHz	dBm	—	68	—
IIP3	Two Tone Input Power up to +5 dBm	dBm	—	39	—
	0.05 GHz 0.05 - 4.0 GHz	dBm	—	46	—
Control Current	V_{IN} Low (0 to -0.2 V)	μA	—	9	—
	V_{IN} High (-5 V @ 25 μA Typ. to -8 V)	μA	—	75	—
T-rise, T-fall	10% to 90% RF and 90% to 10% RF	nS	—	3	—
T_{ON} , T_{OFF}	50% control to 90% RF, and 50% control to 10% RF	nS	—	6	—

Truth Table

Condition of Switch			Control Inputs			Condition of Bond Pad	
	A	B	T	G1	G2	RF1	RF2
Absorptive	V_{IN} Low	V_{IN} Hi	GND	GND	—	On	Off
SPDT	V_{IN} Hi	V_{IN} Low	GND	GND	—	Off	On
Reflective	V_{IN} Low	V_{IN} Hi	—	GND	GND	On	Off

Handling Procedures

Please observe the following precautions to avoid damage:

Static Sensitivity

Gallium Arsenide Integrated Circuits are sensitive to electrostatic discharge (ESD) and can be damaged by static electricity. Proper ESD control techniques should be used when handling these devices.

Typical Performance @ 25°C

Insertion Loss

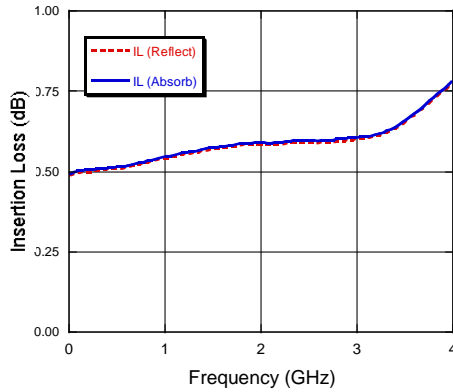

Isolation

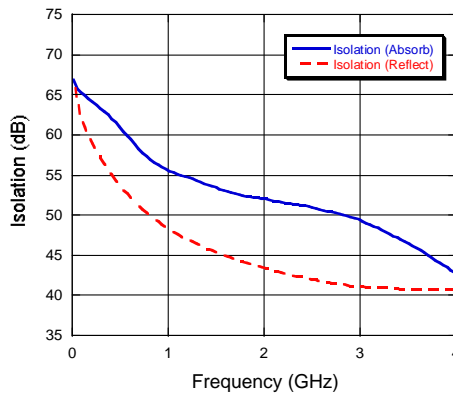

VSWR

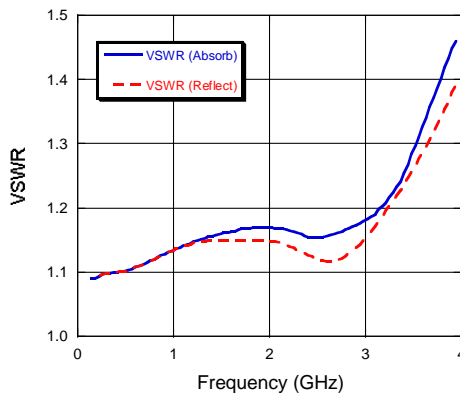

Handling Precautions

Permanent damage to the MASW4030G may occur if the following precautions are not adhered to:

- A. Cleanliness—MASW4030G should be handled in a clean environment. DO NOT attempt to clean unit after the MASW3040G is installed.
- B. Static Sensitivity—All chip handling equipment and personnel should be DC grounded.
- C. Transient—Avoid instrument and power supply transients while bias is applied to the MASW4030G. Use shielded signal and bias cables to minimize inductive pick-up.
- D. Bias—Apply voltage to either of the complementary control ports only when the other is grounded. No port should be allowed to “float”.
- E. General Handling—It is recommended that the MASW4030G chip be handled along the long side of the die with a sharp pair of bent tweezers. DO NOT touch the surface of the chip with fingers or tweezers.

Mounting

The MASW4030G is back-metallized with pd/ni/au (100/1,000, 10,000 Å) metallization. It can be die-mounted with AuSn eutectic preforms or with thermally conductive epoxy. The package surface should be clean and flat before attachment.

Eutectic Die Attach:

- A. A 80/20 gold/tin preform is recommended with a work surface temperature of approximately 255°C and a tool temperature of 265°C. When not 90/10 nitrogen/hydrogen gas is applied, tool tip temperature should be approximately 290°C.
- B. DO NOT expose the MASW4030G to a temperature greater than 320°C for more than 20 seconds. No more than 3 seconds for scrubbing should be required for attachment.

Epoxy Die Attach:

- A. Apply a minimum amount of epoxy and place the MASW4030G into position. A thin epoxy fillet should be visible around the perimeter of the chip.
- B. Cure epoxy per manufacturer's recommended schedule.
- C. Electrically conductive epoxy may be used by is not required.

Wire Bonding

- A. Ball or wedge with 1.0 mil diameter pure gold wire. Thermosonic wirebonding with a nominal stage temperature of 150°C and a ball bonding force of 40 to 50 grams or wedge bonding force of 18 to 22 grams is recommended. Ultrasonic energy and time should be adjusted to the minimum levels achieve reliable wirebonds.
- B. Wirebonds should be started on the chip and terminated on the package. GND bonds should be as short as possible; at least three and no more than four bond wires from ground pads to package are recommended.