

**Silicon PNP Power Transistors**

**2SB1105**

**DESCRIPTION**

- With TO-220C package
- DARLINGTON
- High DC current gain
- Complement to type 2SD1605

**APPLICATIONS**

- Designed for use in low frequency power amplifier applications

**PINNING**

PIN	DESCRIPTION
1	Base
2	Collector;connected to mounting base
3	Emitter

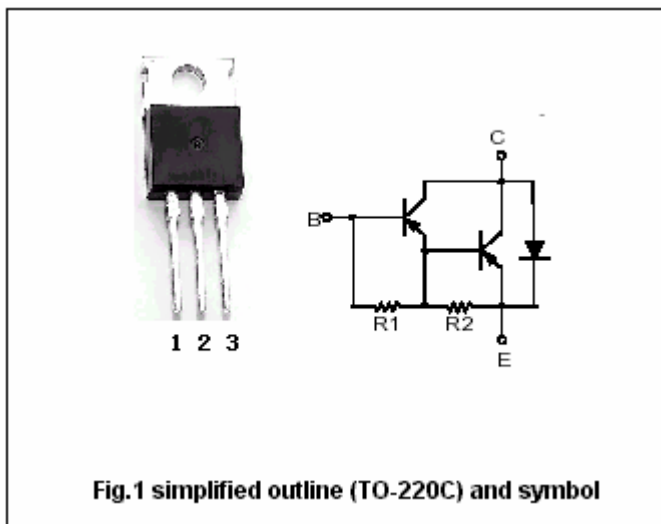

**Absolute maximum ratings(Tc=25 )**

SYMBOL	PARAMETER	CONDITIONS	VALUE	UNIT
$V_{CBO}$	Collector-base voltage	Open emitter	-120	V
$V_{CEO}$	Collector-emitter voltage	Open base	-120	V
$V_{EBO}$	Emitter-base voltage	Open collector	-7	V
$I_C$	Collector current-DC		-3	A
$P_C$	Collector power dissipation	$T_C=25$	30	W
$T_j$	Junction temperature		150	
$T_{stg}$	Storage temperature		-55~150	

## Silicon PNP Power Transistors

## 2SB1105

## CHARACTERISTICS

T<sub>j</sub>=25 unless otherwise specified

SYMBOL	PARAMETER	CONDITIONS	MIN	TYP.	MAX	UNIT
V <sub>(BR)CEO</sub>	Collector-emitter breakdown voltage	I <sub>C</sub> =-25mA, R <sub>BE</sub> =	-120			V
V <sub>(BR)EBO</sub>	Emitter-base breakdown voltage	I <sub>E</sub> =-50mA, I <sub>C</sub> =0	-7			V
V <sub>CEsat-1</sub>	Collector-emitter saturation voltage	I <sub>C</sub> =-1.5A, I <sub>B</sub> =-3mA			-1.5	V
V <sub>CEsat-2</sub>	Collector-emitter saturation voltage	I <sub>C</sub> =-3A, I <sub>B</sub> =-30mA			-3.0	V
V <sub>BEsat-1</sub>	Base-emitter saturation voltage	I <sub>C</sub> =-1.5A, I <sub>B</sub> =-3mA			-2.0	V
V <sub>BEsat-2</sub>	Base-emitter saturation voltage	I <sub>C</sub> =-3A, I <sub>B</sub> =-30mA			-3.5	V
I <sub>CBO</sub>	Collector cut-off current	V <sub>CB</sub> =-120V, I <sub>E</sub> =0			-100	μA
I <sub>CEO</sub>	Collector cut-off current	V <sub>CE</sub> =-100V, R <sub>BE</sub> =			-10	μA
h <sub>FE</sub>	DC current gain	I <sub>C</sub> =-1.5A; V <sub>CE</sub> =-3V	1000			
V <sub>D</sub>	Diode forward voltage	I <sub>D</sub> =-3A			3.0	V

Silicon PNP Power Transistors

2SB1105

PACKAGE OUTLINE

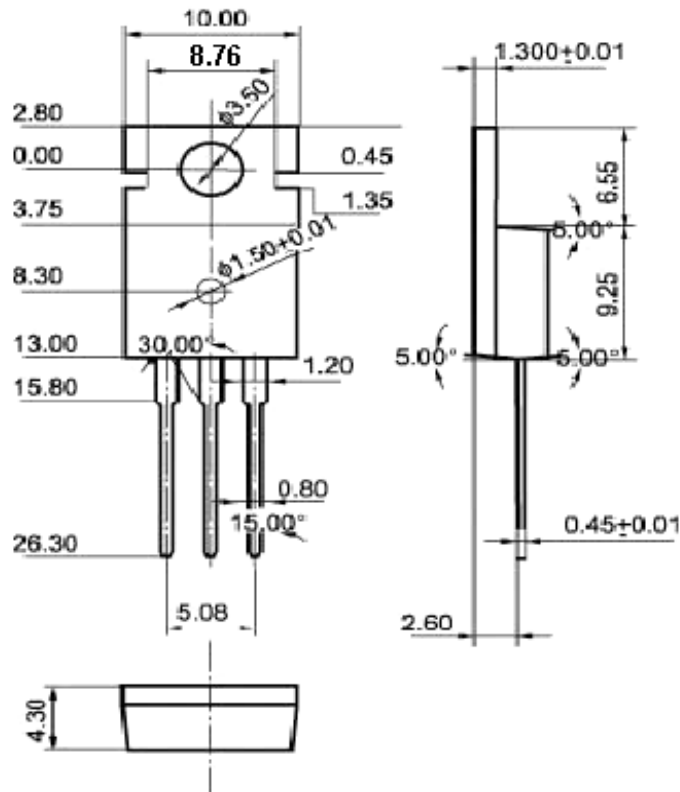

Fig.2 Outline dimensions