

KSH13009



KSH13009

Switch Mode series NPN silicon Power Transistor

- High voltage, high speed power switching
- Suitable for switching regulator, inverters motor controls

Absolute Maximum Ratings TC=25°C unless otherwise noted

12 Amperes
NPN Silicon Power Transistor
100 Watts

| CHARACTERISTICS | SYMBOL | RATING | UNIT |
|--------------------------------|-----------|---------|------|
| Collector-Base Voltage | V_{CBO} | 700 | V |
| Collector-Emitter Voltage | V_{CEO} | 400 | V |
| Emitter-Base Voltage | V_{EBO} | 9 | V |
| Collector Current(DC) | I_C | 12 | A |
| Collector Current(Pulse) | I_{CP} | 24 | A |
| Base Current | I_B | 6 | A |
| Collector Dissipation(Tc=25°C) | P_C | 100 | W |
| Junction Temperature | T_J | 150 | °C |
| Storage Temperature | T_{STG} | -65~150 | °C |

TO-220
1. Base
2. Collector
3. Emitter



Electrical Characteristics TC=25°C unless otherwise noted

| CHARACTERISTICS | SYMBOL | Test Condition | Min | Typ. | Max | Unit |
|---------------------------------------|------------------------|--|--------|------|---------------|-------------|
| Collector-Emitter Sustaining Voltage | $V_{CEO(sus)}$ | $I_C=10mA, I_B=0$ | 400 | | | V |
| Emitter Cut-off Current | I_{EBO} | $V_{EB}=9V, I_C=0$ | | | 1 | mA |
| *DC Current Gain | h_{FE1} h_{FE2} | $V_{CE}=5V, I_C=5A$ $V_{CE}=5V, I_C=8A$ | 8 6 | | 40 30 | |
| *Collector-Emitter Saturation Voltage | $V_{CE(sat)}$ | $I_C=5A, I_B=1A$ $I_C=8A, I_B=1.6A$ $I_C=12A, I_B=3A$ | | | 1 1.5 3 | V V V |
| *Base-Emitter Saturation Voltage | $V_{BE(sat)}$ | $I_C=5A, I_B=1A$ $I_C=8A, I_B=1.6A$ | | | 1.2 1.6 | V V |
| Output Capacitance | C_{ob} | $V_{CB}=10V, f=0.1MHz$ | | 180 | | pF |
| Current Gain Bandwidth Product | f_T | $V_{CE}=10V, I_C=0.5A$ | 4 | | | MHz |
| Turn on Time | t_{on} | $V_{CC}=125V, I_C=8A$ $I_{B1}=1.6A, I_{B2}=-1.6A$ $R_L=15.6\Omega$ | | | 1.1 | μs |
| Storage Time | T_{stg} | | | | 3 | μs |
| Fall Time | t_F | | | | 0.7 | μs |

* Pulse Test: Pulse Width≤300 μs , Duty Cycle≤2%

Note.

Package Mark information.

| | | | | | |
|--------------------------------|----------------------|---------|---|-----|-----------------------------|
| hFE1 Classification | R | 8 ~ 17 | S YWW Z KSH13009 | S | SemiHow Symbol |
| | O | 15~28 | | YWW | Y; year code, WW; week code |
| | Y | 26 ~ 39 | | Z | hFE1 Classification |
| | Y1(26~33), Y2(31~39) | | | | |

Typical Characteristics

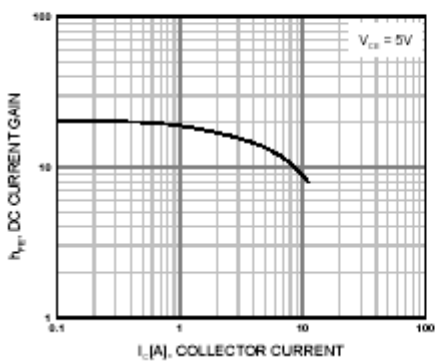

Figure 1. DC current Gain

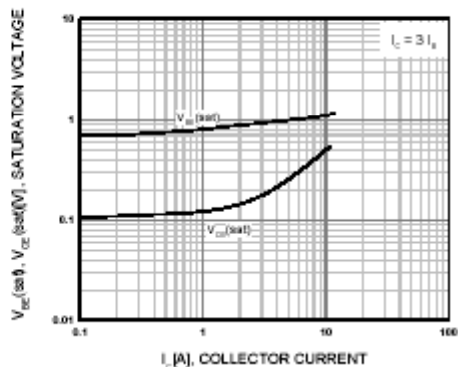

Figure 2. Base-Emitter Saturation Voltage
Collector-Emitter Saturation Voltage

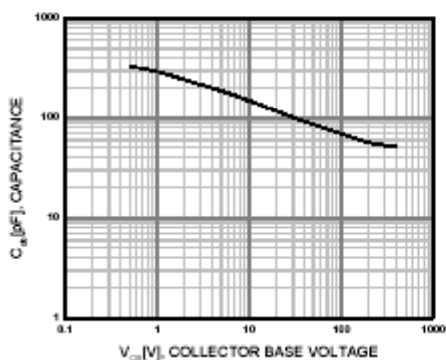

Figure 3. Collector Output Capacitance

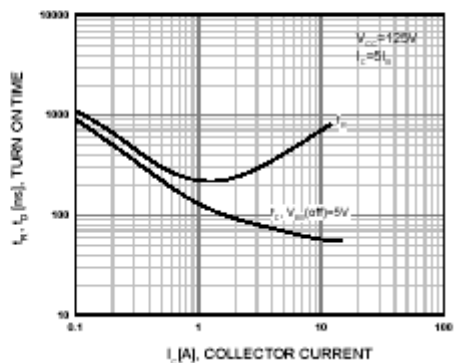

Figure 4. Turn On Time

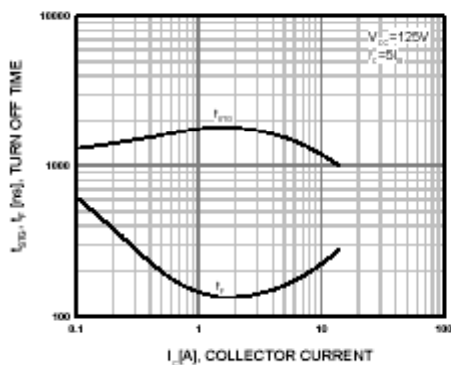

Figure 5. Turn Off Time

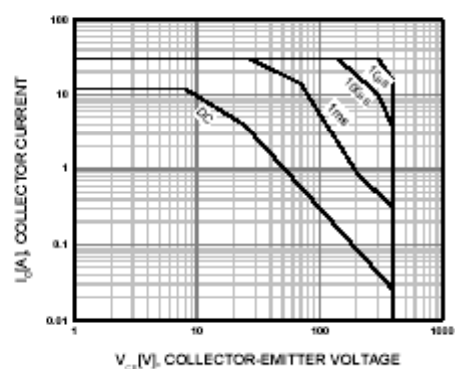

Figure 6. Forward Bias Safe Operating Area

Typical Characteristics (Continued)

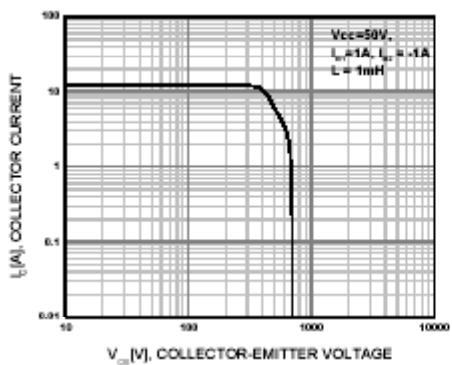

Figure 7. Reverse Bias Safe Operating Area

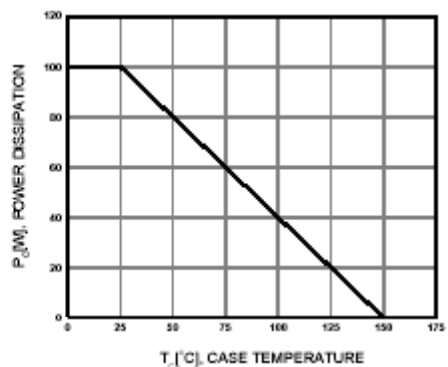
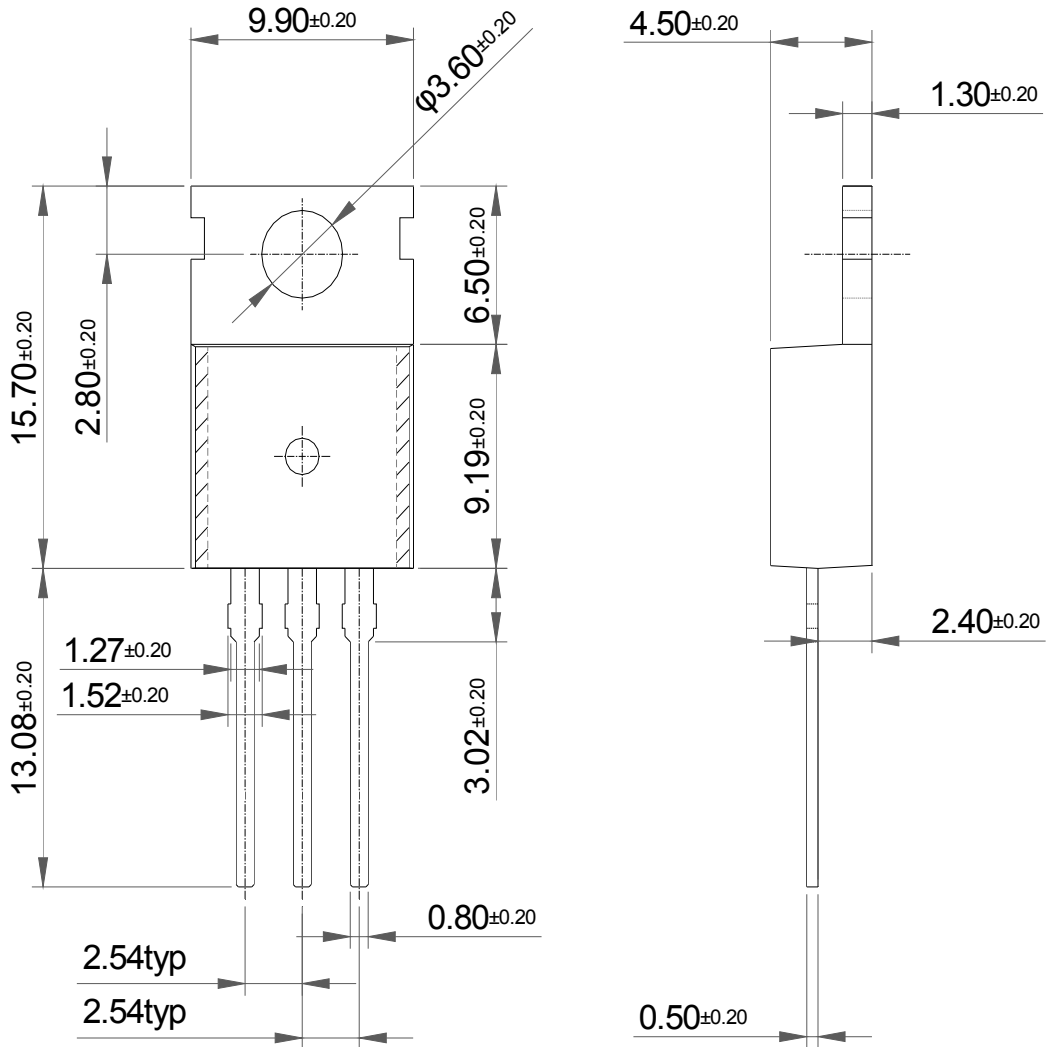

Figure 8. Power Derating

Package Dimension

TO-220 (A)



Dimensions in Millimeters

Package Dimension

TO-220 (B)

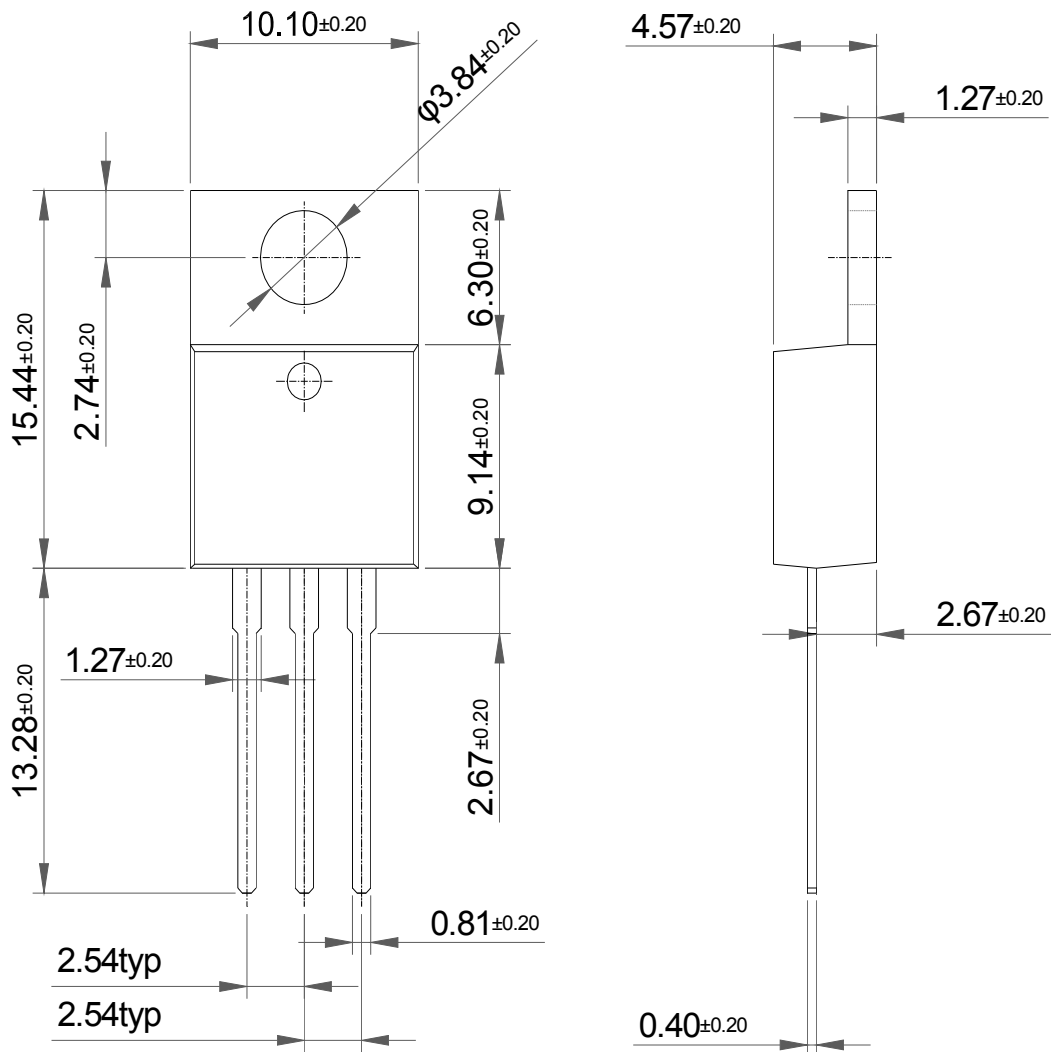

Dimensions in Millimeters