

1.2A/18V PWM Fan Motor Driver

DESCRIPTION

EUM6270 is a PWM fan motor driver for single coil brushless DC motor. With its high efficient direct PWM control mode, EUM6270 controls the speed of brushless DC motor. It builds in an interface between a HALL IC and a single coil motor. EUM6270 is suitable for variable speed control motor for personal computer's power supply radiation fans and CPU coolers.

The EUM6270 functions include PWM control mode, minimum speed mode, fan tachometer, soft switching, lock protection, auto restart, current limit and Hall Bias.

PWM mode controls internal power devices in low noise and low vibration fashion. Minimum speed mode makes the lowest speed of motor settable. If the motor is stalled by external force or obstacles, overdrive current may incur coil overheat and burning. To prevent motor from overheating, the lock protection circuit will shut down the internal power devices for a few seconds after motor is locked up. Then auto restart circuit resumes to power up. The protection and power up time are settable by external capacitor. When the voltage drop between VCC and VM is higher than 0.48V (Typ.), the EUM6270 outputs will be turned off by current limit function. EUM6270 has motor rotation speed feedback (FG) output and Hall sensor bias output.

FEATURES

- Built in 18V Full-wave Fan Driver
- PWM Control Mode
- Built in Soft Switching Function
- Built in Hall Bias
- Settable Minimum Speed Mode
- Lock Protection and Auto Restart
- FG Output
- Current Limit Protection
- Thermal Shutdown Protection
- Available in TSSOP-20 Package
- RoHS Compliant and 100% Lead (Pb)-Free

APPLICATIONS

- Personal Computer's Power Supply Radiation Fans and CPU Coolers

Application Circuit

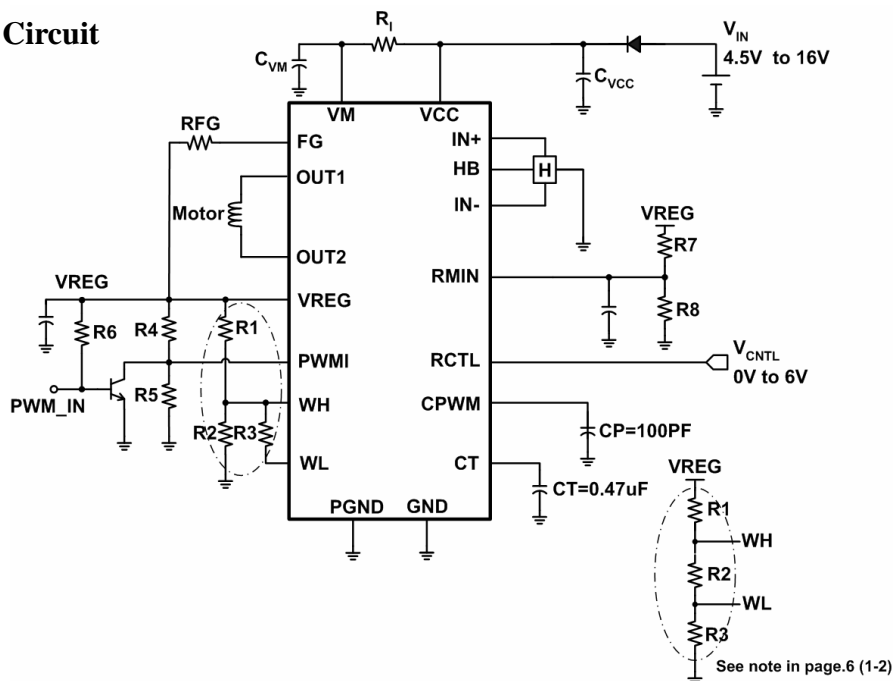

Figure 1. Typical Application Circuit