

MP6 SERIES

SINGLE-PHASE SILICON BRIDGE

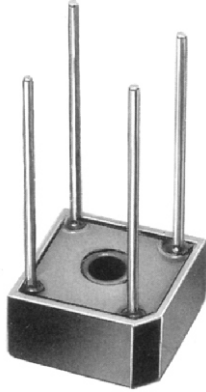

**CHENG-YI
ELECTRONIC**



FEATURES

- Surge overload rating - 125 amperes peak
- Low forward voltage drop
- Small size: simple installation
- Silver Plated Copper Leads
- Mounting Position: Any
- Case: Molded plastic with Heatsink internally mounted in the bridge encapsulation

REVERSE VOLTAGE -50 to 1000 Volts
FORWARD CURRENT -6.0 Amperes

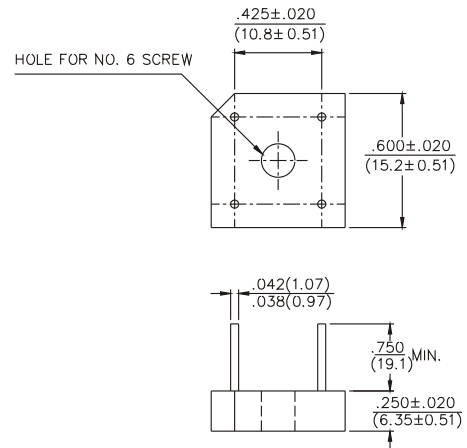

Polarity shown on side of case;
positive lead by beveled corner.

Dimensions in inches and (millimeters)

MAXIMUM RATINGS AND ELECTRICAL CHARACTERISTICS

Ratings at 25°C ambient temperature unless otherwise specified.
Single phase, half wave, 60Hz, resistive or inductive load.
For capacitive load, derate current by 20%.

	MP6005	MP601	MP602	MP604	MP606	MP608	MP610	UNITS
Maximum Recurrent Peak Reverse Voltage	50	100	200	400	600	800	1000	V
Maximum RMS Bridge Input Voltage	35	70	140	280	420	560	700	V
Maximum Average Forward Rectified Output Current at $T_C=100^\circ\text{C}$ (Note1) $T_A=50^\circ\text{C}$ (Note2)	6.0 3.0							A
Peak Forward Surge Current 8.3 ms single half sine-wave super imposed on rated load	125							A
Maximum Forward Voltage Drop per Bridge Element at 3.0A Peak	1.0							V
Maximum Reverse Current at Rated DC Blocking Voltage per Element $T_A=25^\circ\text{C}$ $T_A=100^\circ\text{C}$	10.0 1.0							μA mA
Operating Temperature Range T_C	-55 to +125							$^\circ\text{C}$
Storage Temperature Range T_A	-55 to +150							$^\circ\text{C}$

NOTES: 1. Unit mounted on metal chassis
2. Unit mounted on P.C. Board

MP6 SERIES

SINGLE-PHASE SILICON BRIDGE



**CHENG-YI
ELECTRONIC**

RATING AND CHARACTERISTICS CURVES MP6 SERIES

FIG. 1 - DERATING CURVE FOR
OUTPUT RECTIFIED CURRENT

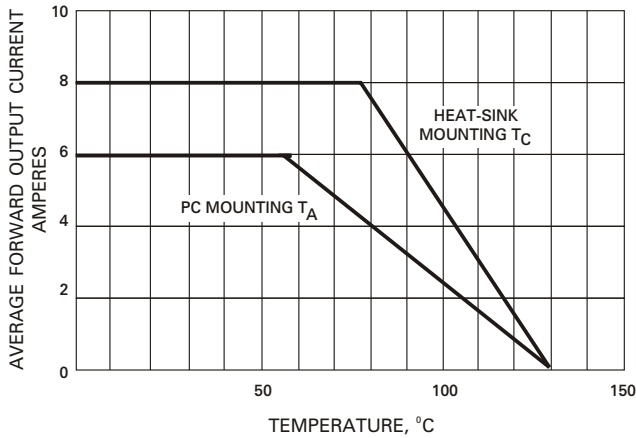

FIG. 2 - TYPICAL REVERSE
CHARACTERISTICS

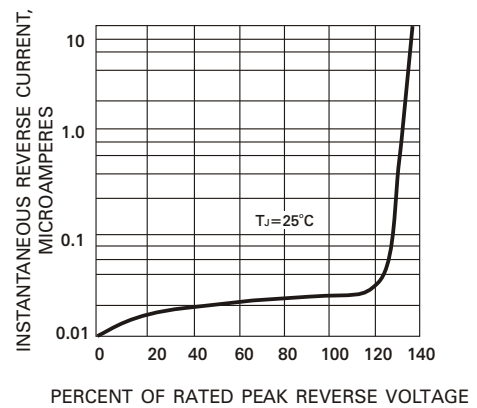

FIG. 3 - MAXIMUM FORWARD SURGE CURRENT

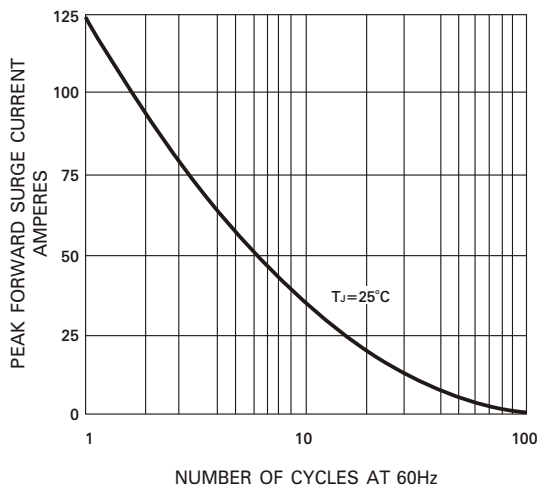

FIG. 4 - TYPICAL INSTANTANEOUS
FORWARD CHARACTERISTICS

