

Voice Switched Speakerphone circuit

■ GENERAL DESCRIPTION

The NJW1124 is a Voice Switched Speakerphone Circuit.

NJW1124 includes all of functions processing a high quality hands-free speakerphone system, such as the necessary amplifiers (Microphone , Receive ,Line), attenuators, level detectors functions.

All external capacitors are sufficient small so that ceramic capacitors are applied.

■ PACKAGE OUTLINE



NJW1124V

■ APPLICATION

- Video Door Phone
- Conference System
- Wireless Application
- Security System

■ FEATURES

- Operating voltage range 2.9 to 4.5V
- Force to Receive, Transmit, or Idle modes
- Mode –watching monitor
- Attenuator gain range between Transmit and Receive 52dB
- Microphone amplifier with mute function
- Background noise monitor for each path
- Volume control range 40dB
- 4-point signal sensing
- Microphone and Receive Amplifiers pinned out for flexibility
- Package Outline SSOP32

■ BLOCK DIAGRAM

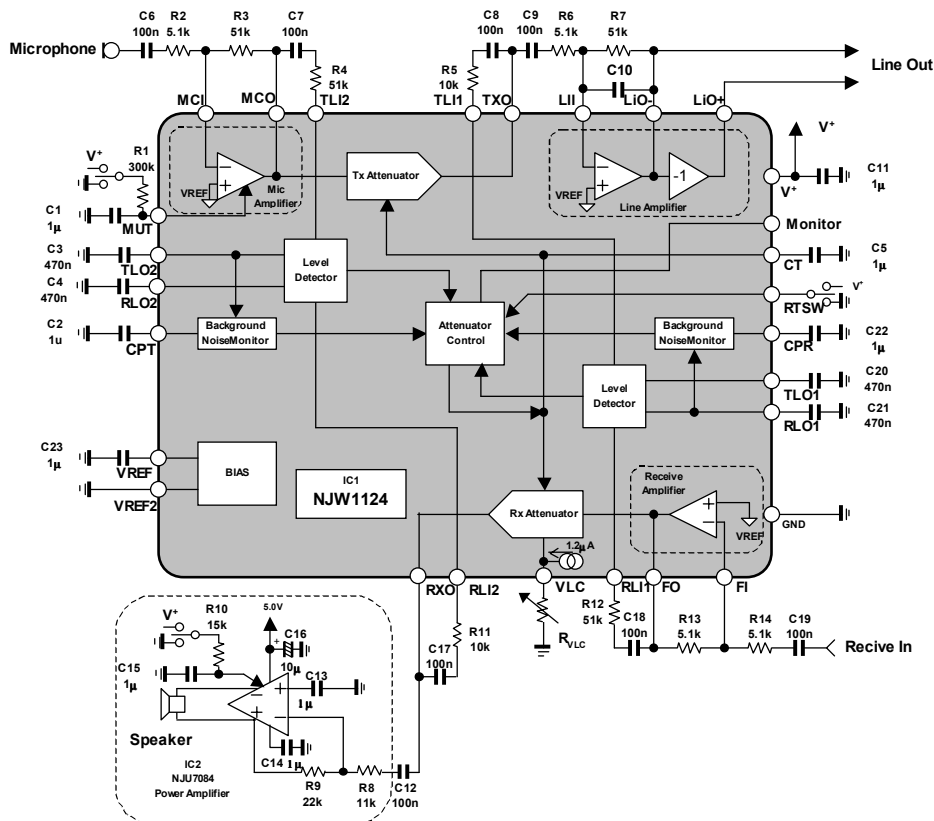

NJW1124

■PIN CONFIGURATION

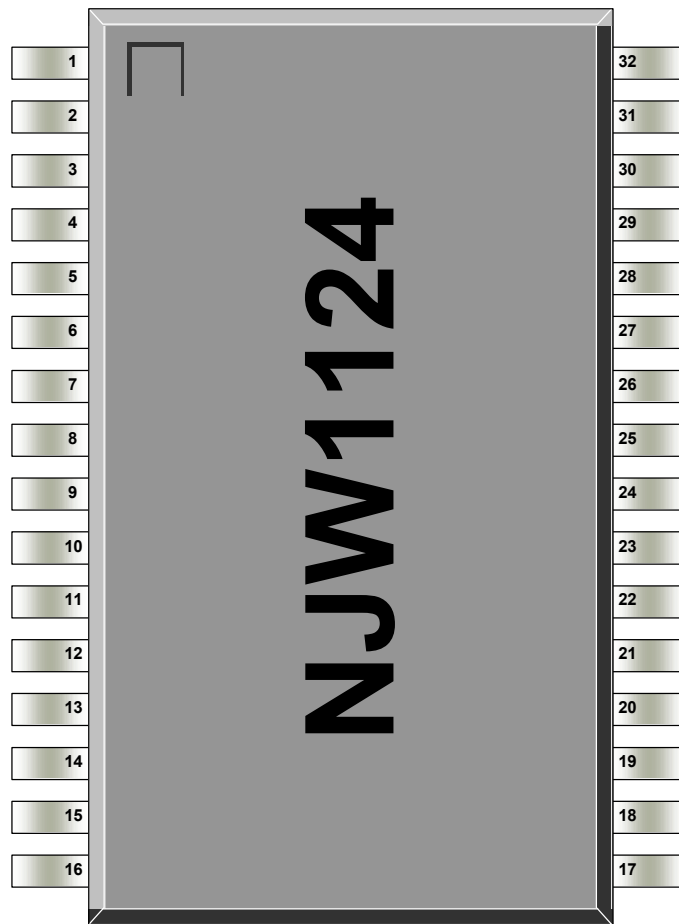

1	VREF2	32	MON
2	MUT	31	RTSW
3	NC	30	VREF
4	CPT	29	CPR
5	TLO2	28	RLO1
6	RLO2	27	TLO1
7	CT	26	VLC
8	MCI	25	FI
9	MCO	24	FO
10	TLI2	23	RLI1
11	TLI1	22	RLI2
12	TXO	21	R XO
13	LII	20	NC
14	LIO-	19	NC
15	LIO+	18	NC
16	GND	17	V+

■ ABSOLUTE MAXIMUM RATING (Ta=25°C)

PARAMETER	SYMBOL	RATING	UNIT
Power Supply Voltage	V ₊	5.5	V
Power Dissipation	P _D	800 (Note1)	mW
Operating Temperature Range	Topr	-40 ~ +85	°C
Storage Temperature Range	Tstg	-40 ~ +125	°C
Maximum Input Voltage	V _{IMAX}	0 ~ V ⁺	V

(Note1) EIA/JEDEC STANDARD Test board (76.2x114.3x1.6mm, 2layer, FR-4) mounting

(Note2) Don't apply the input voltage that exceeds supply voltage.

■ OPERATING VOLTAGE

PARAMETER	SYMBOL	TEST CONDITION	MIN.	TYP.	MAX.	UNIT
Operating Voltage	V ⁺	-	2.9	4.0	4.5	V

■ ELECTRICAL CHARACTERISTICS (Ta=25°C, V⁺=4V, MUT=ACTIVE, RTSW=OPEN, R_{VLC}=0Ω, G_{VM}=0dB, Receive Amplifier G_V=0dB)

PARAMETER	SYMBOL	TEST CONDITION	MIN.	TYP.	MAX.	UNIT
Operating Current 1	I _{CC1}	RX-mode (Receive)	0.7	2.0	4.0	mA
Operating Current 2	I _{CC2}	TX-mode (Transmit)	0.7	2.0	4.0	mA
Operating Current 3	I _{CC3}	Idle-mode	0.7	2.0	4.0	mA
Reference Voltage	V _{REF}	Idle-mode	1.7	2.0	2.3	V

● Receive Attenuator (RxIN=100Vrms, Receive Amplifier G_V=0dB)

PARAMETER	SYMBOL	TEST CONDITION	MIN.	TYP.	MAX.	UNIT
Receive Attenuator Gain 1	G _{R1}	RX-mode (Receive)	3.0	6.0	9.0	dB
Receive Attenuator Gain 2	G _{R2}	TX-mode (Transmit)	-43	-46	-50	dB
Receive Attenuator Gain 3	G _{R3}	Idle-mode (Standby), CPT=CPR=V ⁺	-17	-20	-23	dB
Range R to T mode	ΔG _R	RX-mode – TX-mode	47	52	57	dB
Dynamic DC offset	G _{RDC}	RX-mode – TX-mode (DC)	-50	-	50	mV
Volume control range	G _{RVR}	RX-mode, R _{VLC} =0Ω-100kΩ	30	40	50	dB
Maximum Detector Sink Current	I _{RSINKMAX}	RLI1, TLI1, Maximum Sink Current	-	-	200	μA

● Transmit Attenuator (TxIN=100Vrms, Mic. amplifier G_V=0dB)

PARAMETER	SYMBOL	TEST CONDITION	MIN.	TYP.	MAX.	UNIT
Transmit Attenuator Gain 1	G _{T1}	TX-mode (Transmit)	3.0	6.0	9.0	dB
Transmit Attenuator Gain 2	G _{T2}	RX-mode (Receive)	-43	-46	-50	dB
Transmit Attenuator Gain 3	G _{T3}	Idle-mode CPT=CPR=V ⁺	-17	-20	-23	dB
Range R to T mode	ΔG _T	TX-mode – RX-mode	47	52	57	dB
Dynamic DC offset	G _{TDC}	TX-mode – RX-mode (DC)	-50	-	50	mV
Volume control range	G _{TVR}	RX-mode, R _{VLC} =0Ω-100kΩ	31	40	46	dB
Maximum Detector Sink Current	I _{RSINKMAX}	RLI1, TLI1, Maximum Sink Current	-	-	200	μA

●MIC Amplifier (TxIN=1mVrms, Gv=40dB, RL=5.1kΩ)

PARAMETER	SYMBOL	TEST CONDITION	MIN.	TYP.	MAX.	UNIT
Output Offset Voltage	V _{MOS}	R5=300kΩ, V _{MOS} =V _{MCI} -V _{MCO}	-30	0.0	30	mV
Input Bias Current	I _{MBIAS}	-	-	0.0	-	nA
Voltage Gain 1	G _{VM1}	f=1kHz	-	40	-	dB
Voltage Gain 2	G _{VM2}	f=20kHz	-	38	-	dB
Maximum Output Voltage	V _{MMAX}	THD=1%	0.9	-	-	Vrms
Maximum Output Current	I _{MOMAX}	-	-	1.5	-	mA
Maximum Attenuation	G _{Mmute}	R5=300kΩ	70	73	-	dB

●Receive Amplifier (RxIN=1mVrms, Gv=40dB, RL=5.1kΩ)

PARAMETER	SYMBOL	TEST CONDITION	MIN.	TYP.	MAX.	UNIT
Output Offset Voltage	V _{ROS}	RF=300kΩ, V _{FOS} =V _{FI} -V _{FO}	-30	0.0	30	mV
Input Bias Current	I _{RBIAS}	-	-	30	-	nA
Voltage Gain 1	G _{VR1}	f=1kHz	-	40	-	dB
Voltage Gain 2	G _{VR2}	f=20kHz	-	38	-	dB
Maximum Output Voltage	V _{RMAX}	THD=1%	0.9	-	-	mVrms
Maximum Output Current	I _{ROMAX}	-	-	1.5	-	mA

●Line Amplifier (LINEIN=50mVrms, Gv=26dB, RL=1.2kΩ)

PARAMETER	SYMBOL	TEST CONDITION	MIN.	TYP.	MAX.	UNIT
Output Offset Voltage	V _{LOS}	R9=51kΩ	20	0.0	20	mV
Input Bias Current	I _{LBIAS}	-	-	0.0	-	nA
Voltage Gain 1	G _{VL1}	f=1kHz	-	26	-	dB
Voltage Gain 2	G _{VL2}	f=20kHz	-	25	-	dB
Closed Loop Gain	G _{LC}	LIO- to LIO+	-0.5	0	0.5	dB
Maximum Output Voltage	V _{LMAX}	THD=1%	1.5	-	-	Vrms
Total Harmonic Distortion	THD _{LN}	f=1kHz	-	-	0.5	%
Maximum Output Current	I _{LOMAX}	-	-	4.0	-	mA

●Monitor Terminal (32Pin) Output Voltage

PARAMETER	SYMBOL	TEST CONDITION	MIN.	TYP.	MAX.	UNIT
Rx-mode	Rx	-	V ⁺ -0.3	-	-	V
Tx-mode	Tx	-	-	-	0.3	V
Idle-mode	Idle	No Signal	-	V ⁺ /2	-	V
Maximum Output Current	I _{MON}	Rx-mode / Tx-mode	-	1.0	-	mA

■ CONTROL CHARACTERISTICS (MUT)

PARAMETER	SYMBOL	TEST CONDITION	MIN.	TYP.	MAX.	UNIT
Low Level Input Voltage	V_{IL1}	-	-	-	0.3	V
High Level Input Voltage	V_{IH1}	-	1.5	-	-	V

■ CONTROL CHARACTERISTICS (RTSW)

PARAMETER	SYMBOL	TEST CONDITION	MIN.	TYP.	MAX.	UNIT
Low Level Input Voltage	V_{IL2}	-	-	-	0.3	V
High Level Input Voltage	V_{IH2}	-	$V^+ - 0.3$	-	-	V

■ FUNCTION

●MUT (2pin)

INPUT VOLTAGE	STATUS	OPERATION
V_{IH}	MUTE	The microphone input is made a mute.
V_{IL}	ACTIVE	The microphone input is active.

●RTSW (31pin)

INPUT VOLTAGE	STATUS	OPERATION
V_{IH}	Receive	Force to Receive mode.
OPEN	AUTO	Receive mode and Transmit mode are automatically switched.
V_{IL}	Transmit	Force to Transmit mode.

● R_{VLC} (26pin)

IMPEDANCE	STATUS	OPERATION
0	Vol_{MAM}	The Receive attenuator Volume is maximum.
100k Ω	Vol_{MIN}	The Receive attenuator Volume is minimum.

NJW1124

MEASUREMENT CIRCUIT

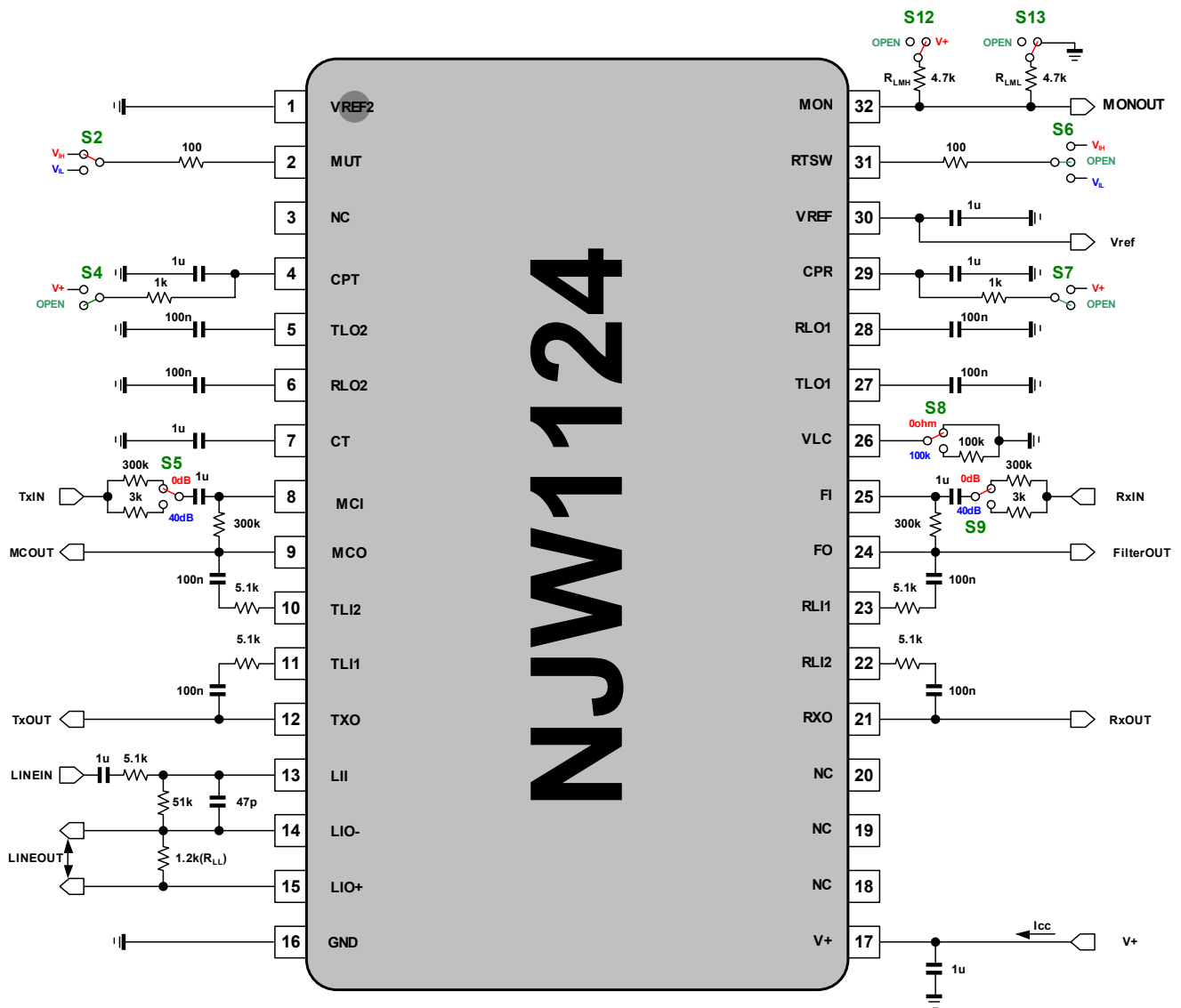

APPLICATION CIRCUIT

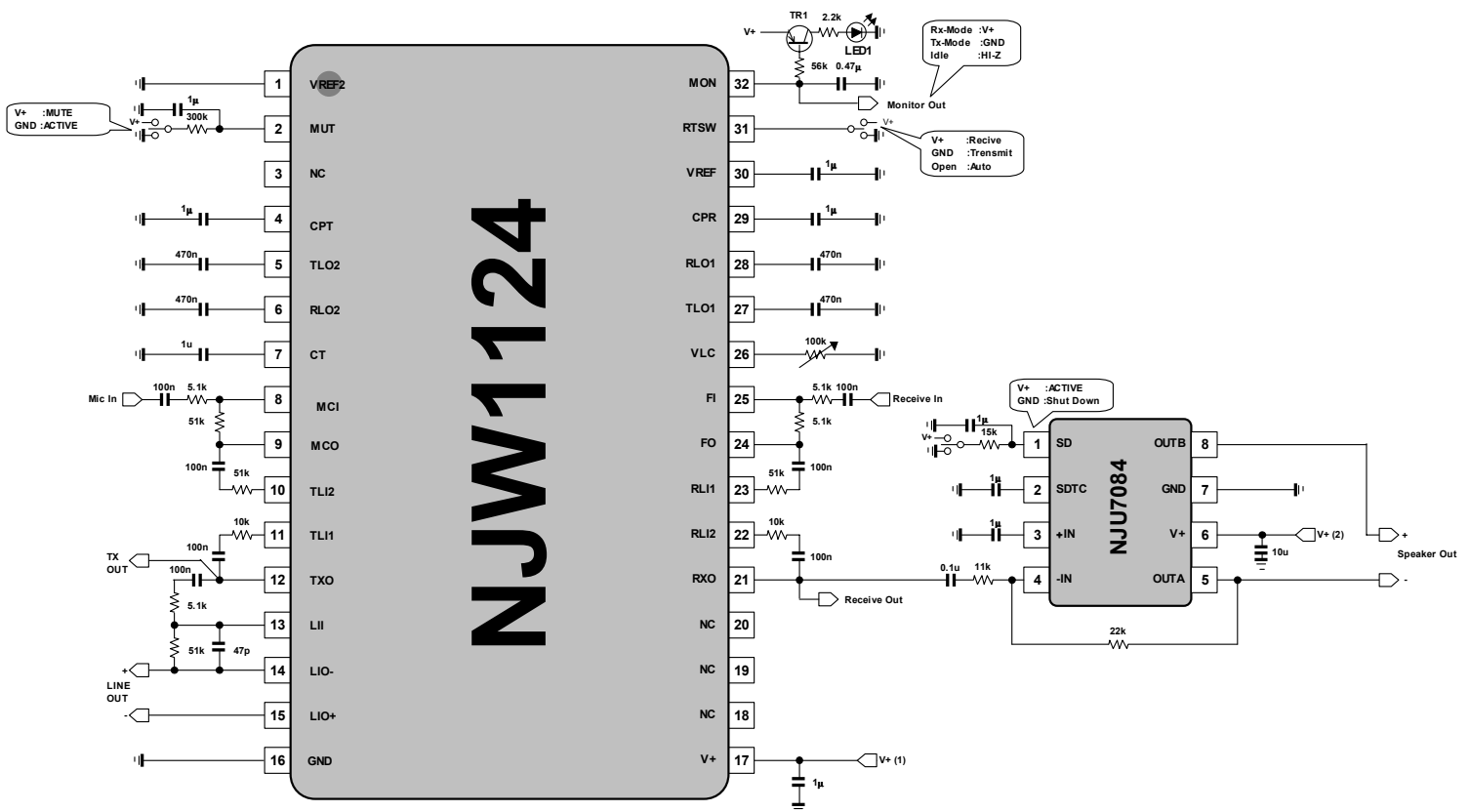

TYPICAL CHARACTERISTICS

Volume control range vs ambient temperature
(VLC=0Ω/100kΩ)

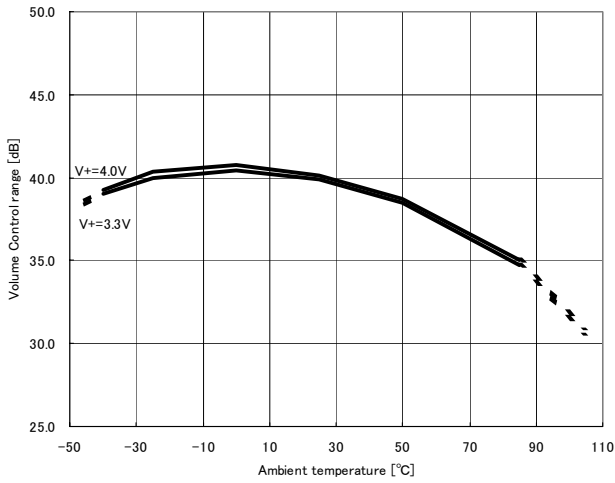

Detector Max Sink Current vs ambient temperature
(TLI1, TLI2, RL1, RL2 Max Sink Current)

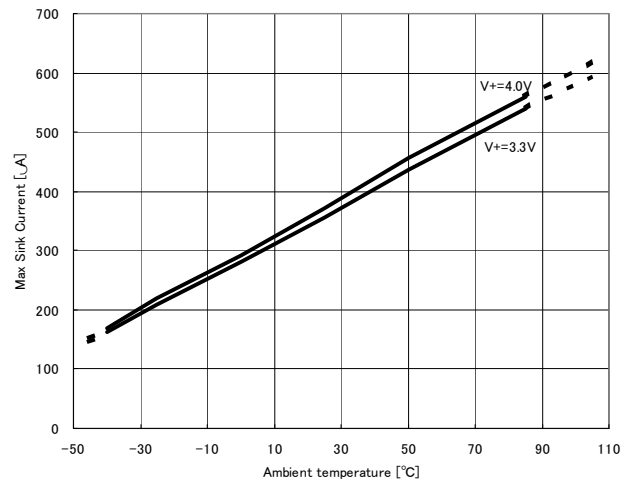

Tx ATT Gain vs ambient temperature
(V+=3.3V, Receive Amp Gain = 0dB, VLC=0Ω)

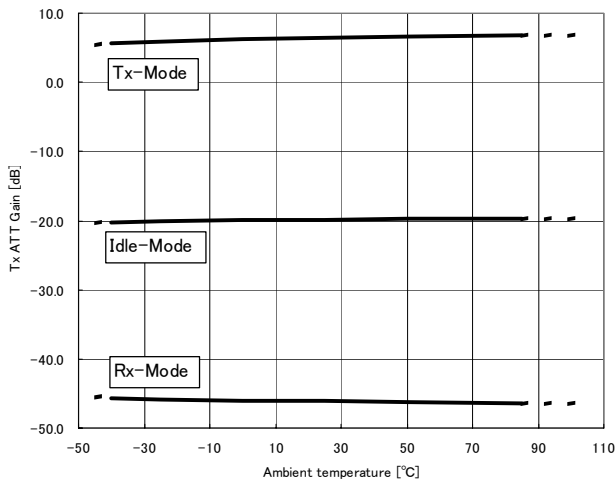

Tx ATT Gain vs ambient temperature
(V+=4.0V, Receive Amp Gain = 0dB, VLC=0Ω)

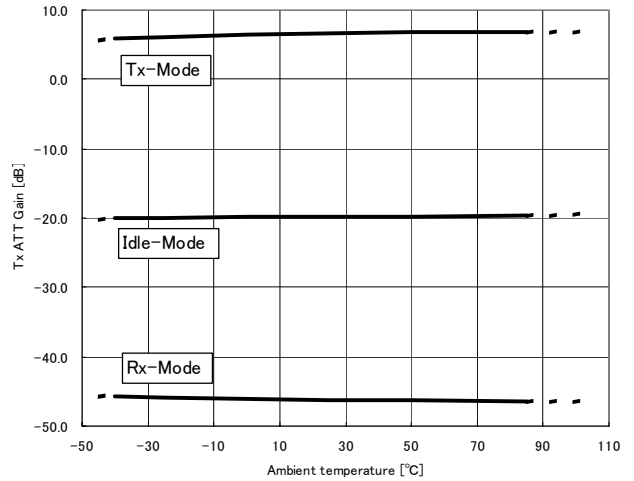

Monitor Out vs ambient temperature
(V+=3.3V, RLMH=RLML=4.7kΩ)

note : The MONITOR OUT(@Idle-mode) is Hi-Z when there are neither RLMH and RLML.

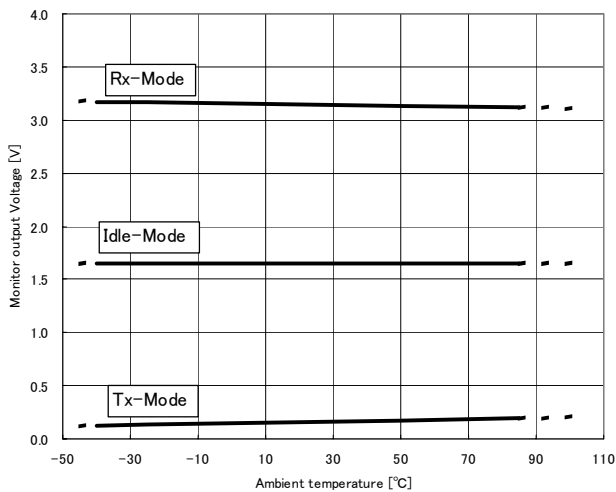

Monitor Out vs ambient temperature
(V+=4.0V, RLMH=RLML=4.7kΩ)

note : The MONITOR OUT(@Idle-mode) is Hi-Z when there are neither RLMH and RLML.

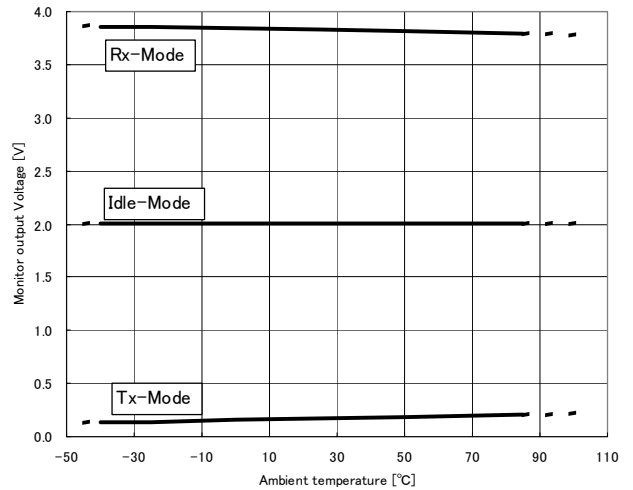

TYPICAL CHARACTERISTICS

MUTE Pin Voltage vs MUTE ATT Ratio
(V+=3.3V, MICAMP GAIN=40dB, Rf=300kΩ, Ri=3kΩ, A-weighted)

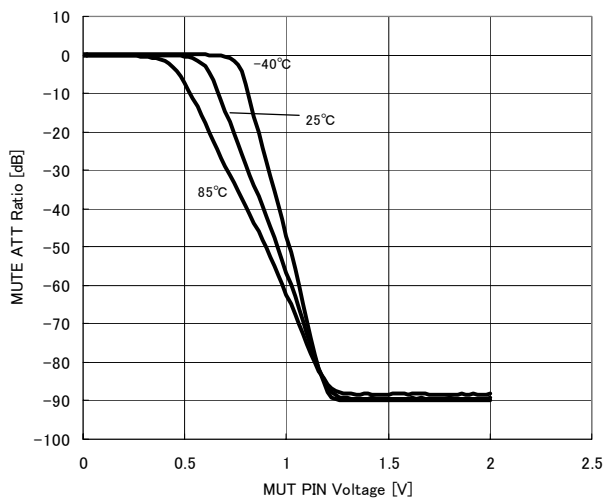

MUTE Pin Voltage vs MUTE ATT Ratio
(V+=4.0V, MICAMP GAIN=40dB, Rf=300kΩ, Ri=3kΩ, A-weighted)

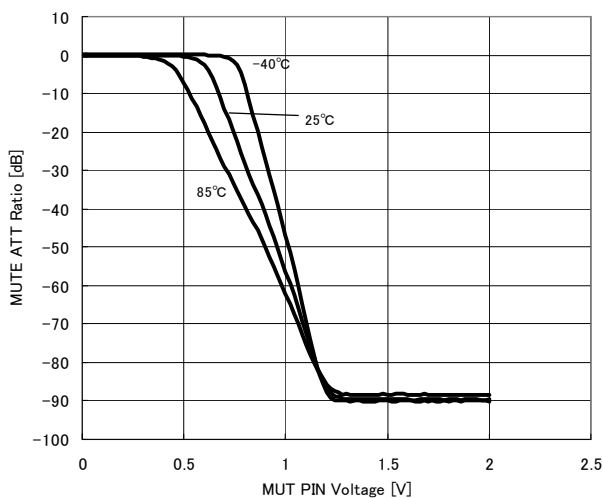

MUTE Pin Voltage vs MUTE ATT Ratio
(V+=3.3V, MICAMP GAIN=0dB, Rf=3kΩ, Ri=3kΩ, A-weighted)

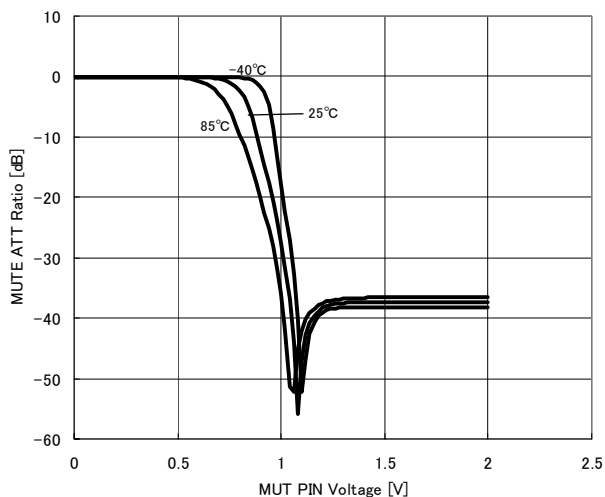

MUTE Pin Voltage vs MUTE ATT Ratio
(V+=4.0V, MICAMP GAIN=0dB, Rf=3kΩ, Ri=3kΩ, A-weighted)

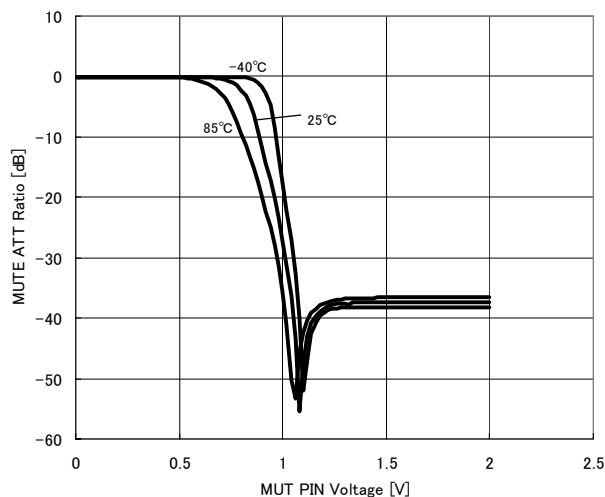

MICAMP Gain vs Frequency
(V+=3.3V, RL=5.1kΩ, Cin=1μF, Rin=3kΩ)

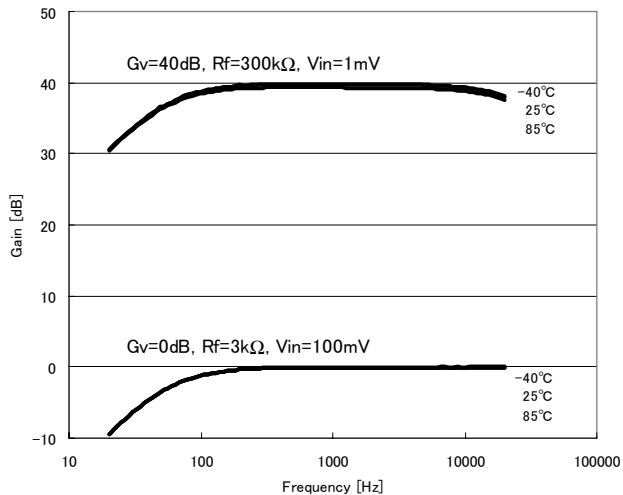

MICAMP Gain vs Frequency
(V+=4.0V, RL=5.1kΩ, Cin=1μF, Rin=3kΩ)

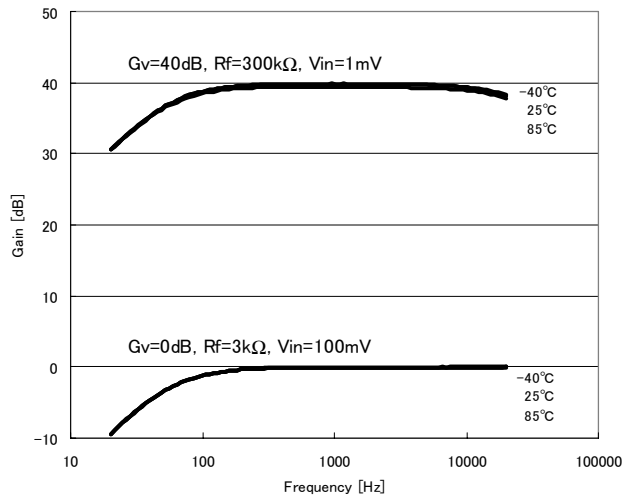

TYPICAL CHARACTERISTICS

Receive AMP Gain vs Frequency
(V+=3.3V, RL=5.1kΩ, Cin=1μF, Rin=3kΩ)

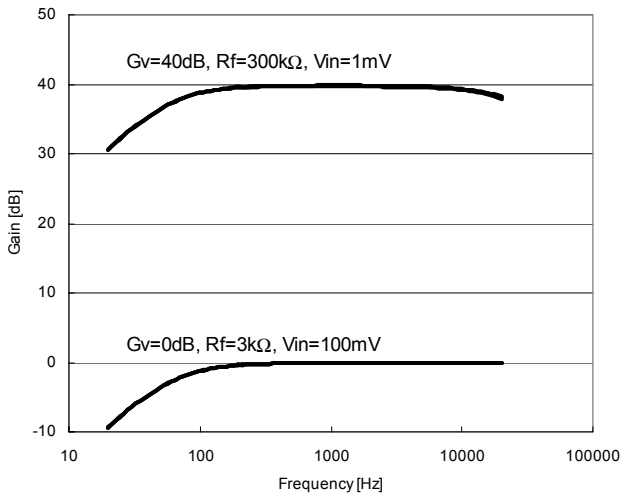

Receive AMP Gain vs Frequency
(V+=4.0V, RL=5.1kΩ, Cin=1μF, Rin=3kΩ)

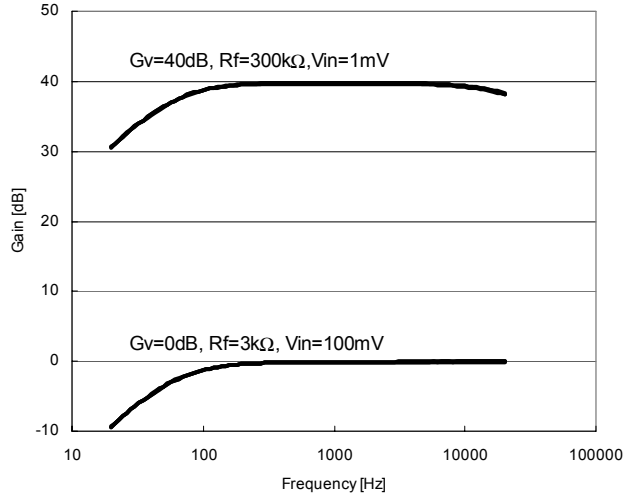

LINEAMP Gain vs Frequency
(V+=3.3V, RL=1.2kΩ, Cin=1μF, Rf=51kΩ, Rin=5.1kΩ, Cf=47pF)

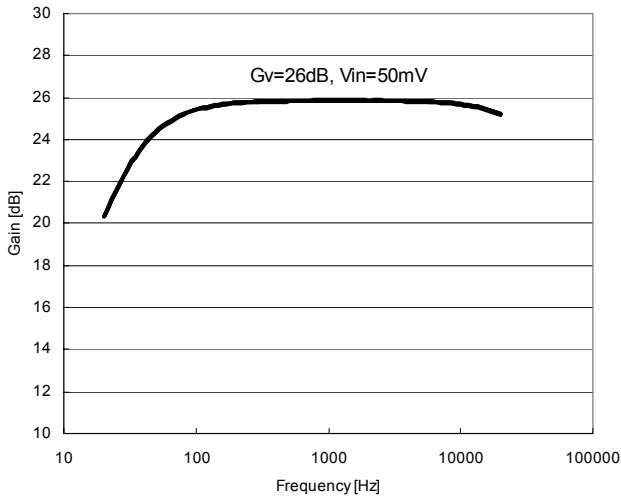

LINEAMP Gain vs Frequency
(V+=4.0V, RL=1.2kΩ, Cin=1μF, Rf=51kΩ, Rin=5.1kΩ, Cf=47pF)

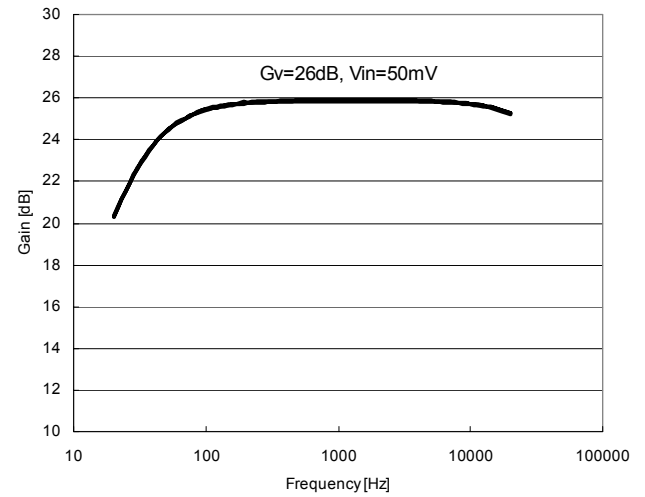

Receive AMP THD+N vs Input Voltage
(V+=3.3V, RL=5.1kΩ, Gain=40dB, Rf=300kΩ, Ri=3kΩ, BW=400Hz~30kHz)

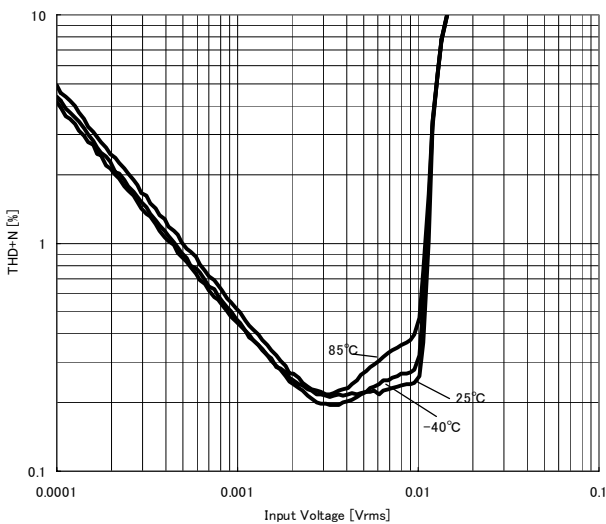

Receive AMP THD+N vs Input Voltage
(V+=4.0V, RL=5.1kΩ, Gain=40dB, Rf=300kΩ, Ri=3kΩ, BW=400Hz~30kHz)

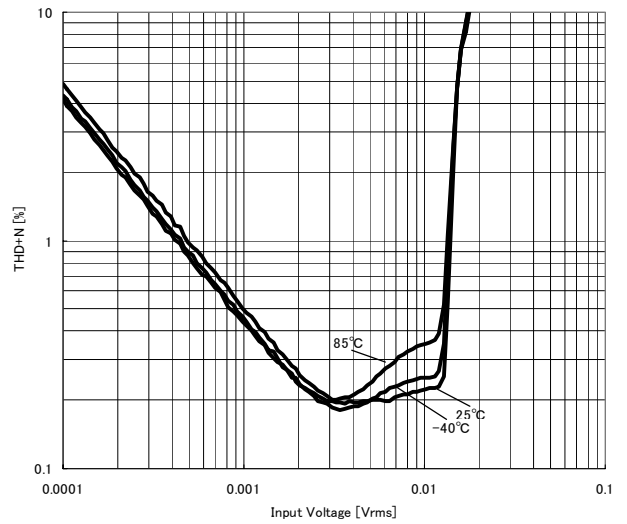

TYPICAL CHARACTERISTICS

Receive AMP THD+N vs Input Voltage
(V+=3.3V, RL=5.1kΩ, Gain=0dB, RF=3kΩ, Ri=3kΩ, BW:400Hz~30kHz)

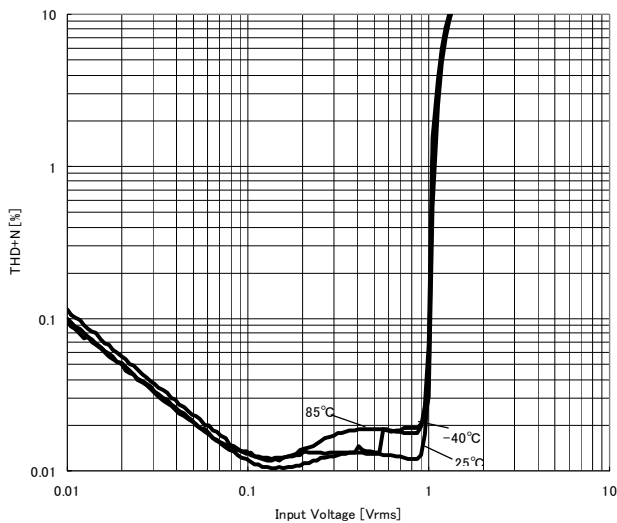

Receive AMP THD+N vs Input Voltage
(V+=4.0V, RL=5.1kΩ, Gain=0dB, RF=3kΩ, Ri=3kΩ, BW:400Hz~30kHz)

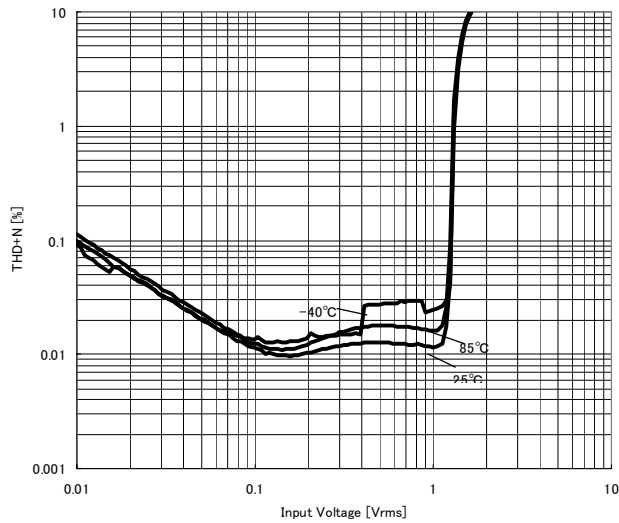

Mic AMP THD+N vs Input Voltage
(V+=3.3V, MUT=0.3V, RL=5.1kΩ, Gain=40dB, RF=300kΩ, Ri=3kΩ, BW:400Hz~30kHz)

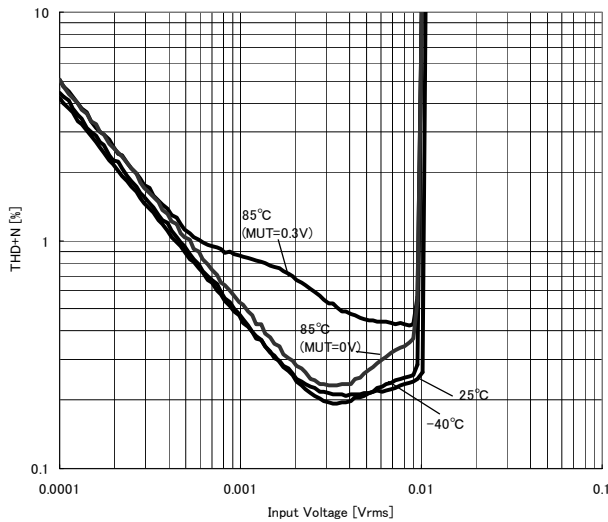

Mic AMP THD+N vs Input Voltage
(V+=4.0V, MUT=0.3V, RL=5.1kΩ, Gain=40dB, RF=300kΩ, Ri=3kΩ, BW:400Hz~30kHz)

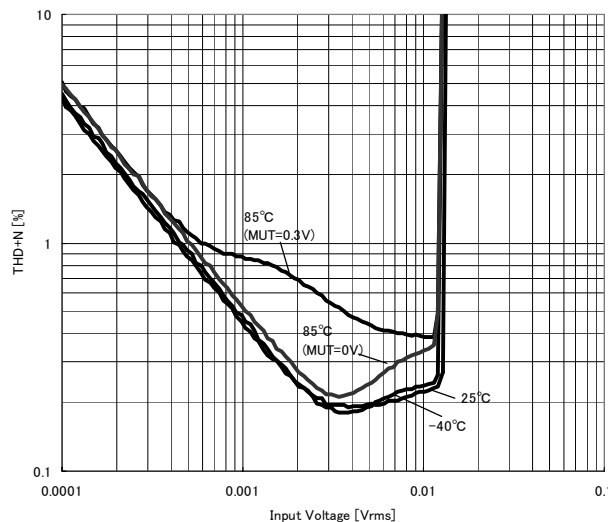

Mic AMP THD+N vs Input Voltage
(V+=3.3V, MUT=0.3V, RL=5.1kΩ, Gain=40dB, RF=300kΩ, Ri=3kΩ, BW:400Hz~30kHz)

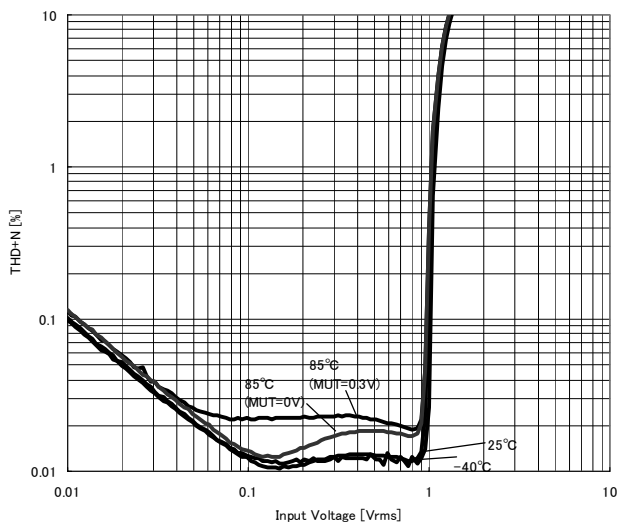

Mic AMP THD+N vs Input Voltage
(V+=4.0V, MUT=0.3V, RL=5.1kΩ, Gain=40dB, RF=300kΩ, Ri=3kΩ, BW:400Hz~30kHz)

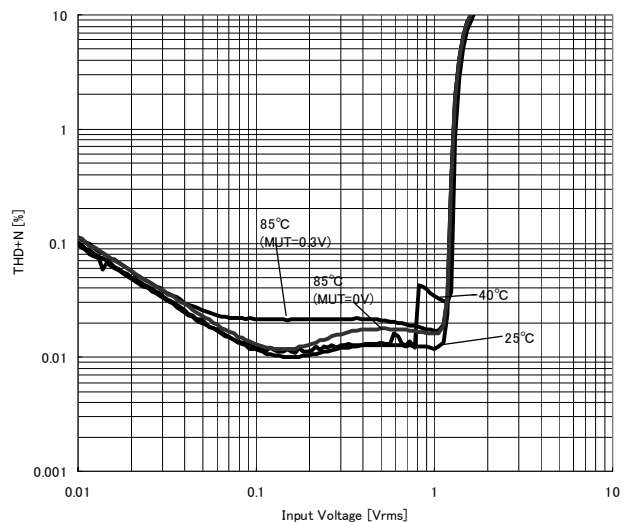

TYPICAL CHARACTERISTICS

LINE AMP THD+N vs Input Voltage
(V+=3.3V, RL=1.2kΩ, Gain=26dB, RF=51kΩ, RI=5.1kΩ, BW=400Hz~30kHz)

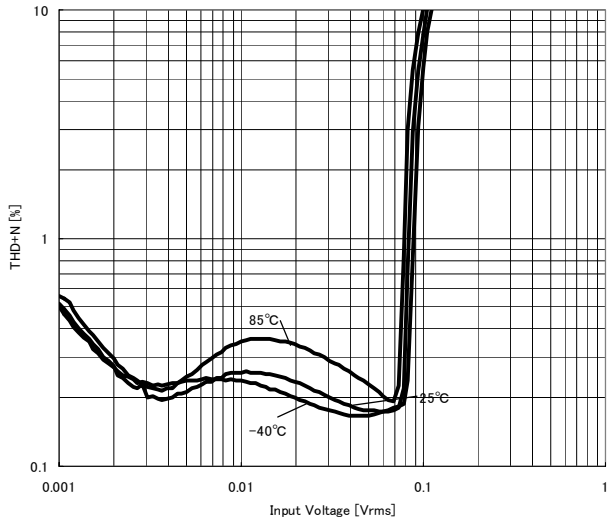

LINE AMP THD+N vs Input Voltage
(V+=4.0V, RL=1.2kΩ, Gain=26dB, RF=51kΩ, RI=5.1kΩ, BW=400Hz~30kHz)

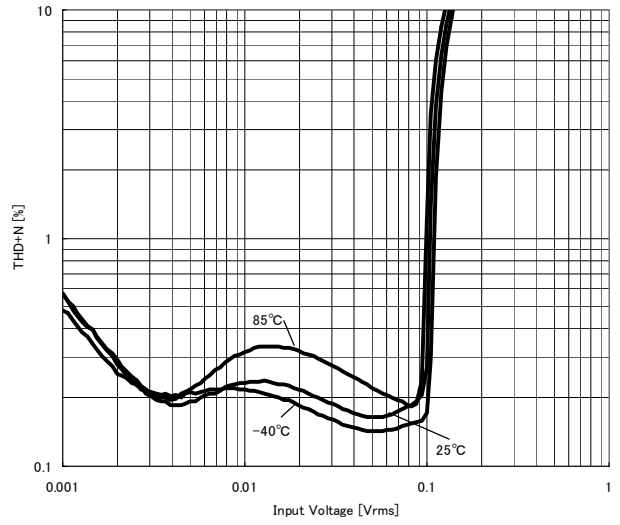

RTSW PIN Voltage vs Rx&Tx ATT. Gain
(V+=3.3V)

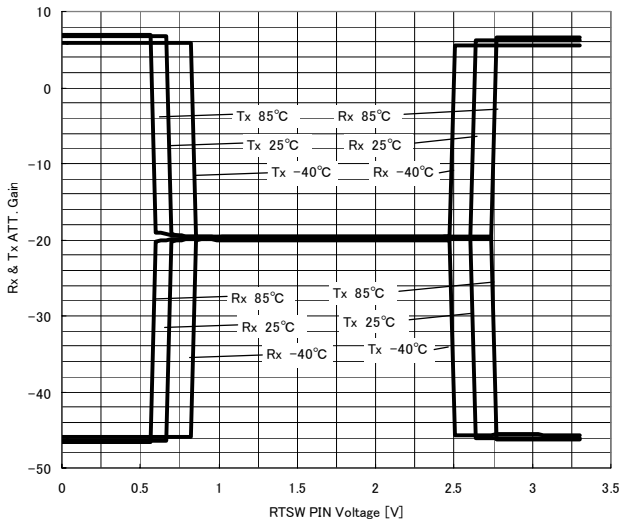

RTSW PIN Voltage vs Rx&Tx ATT. Gain
(V+=4.0V)

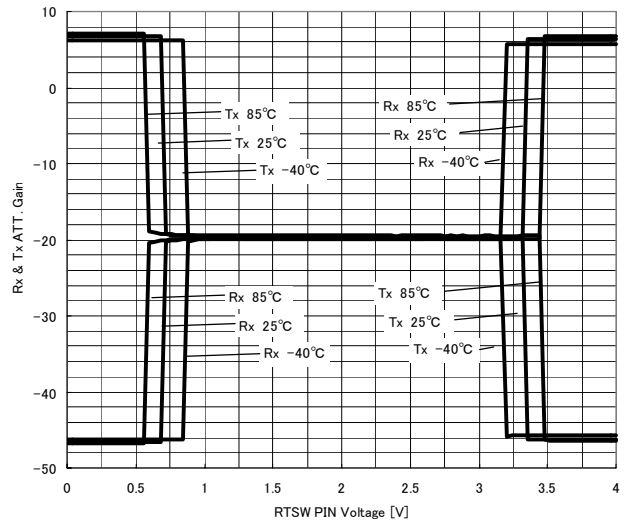

APPLICATION NOTES

GENERAL DESCRIPTION

The **NJW1124** is a Voice Switched Speakerphone Circuit. The **NJW1124** includes all of functions processing a high quality hands-free speakerphone system, such as the necessary amplifiers (Microphone amplifier , Receive amplifier, Line amplifier), attenuators, level detectors .

All external capacitors are sufficient small so that ceramic capacitors are applied.

The **NJW1124** detects a signal to judges which path is talking. After that, the one side path is active, another path is attenuated. This is half-duplex system. Appropriate operating keeps closed loop gain less than 0dB, and that prevents acoustic coupling.

The resistor and capacitor values in Fig.1 below are references. For correct operating, check in actual condition as possible as you can. And adjust the levels input each detectors.

On this application notes, Base unit is defined as the unit included the **NJW1124**.

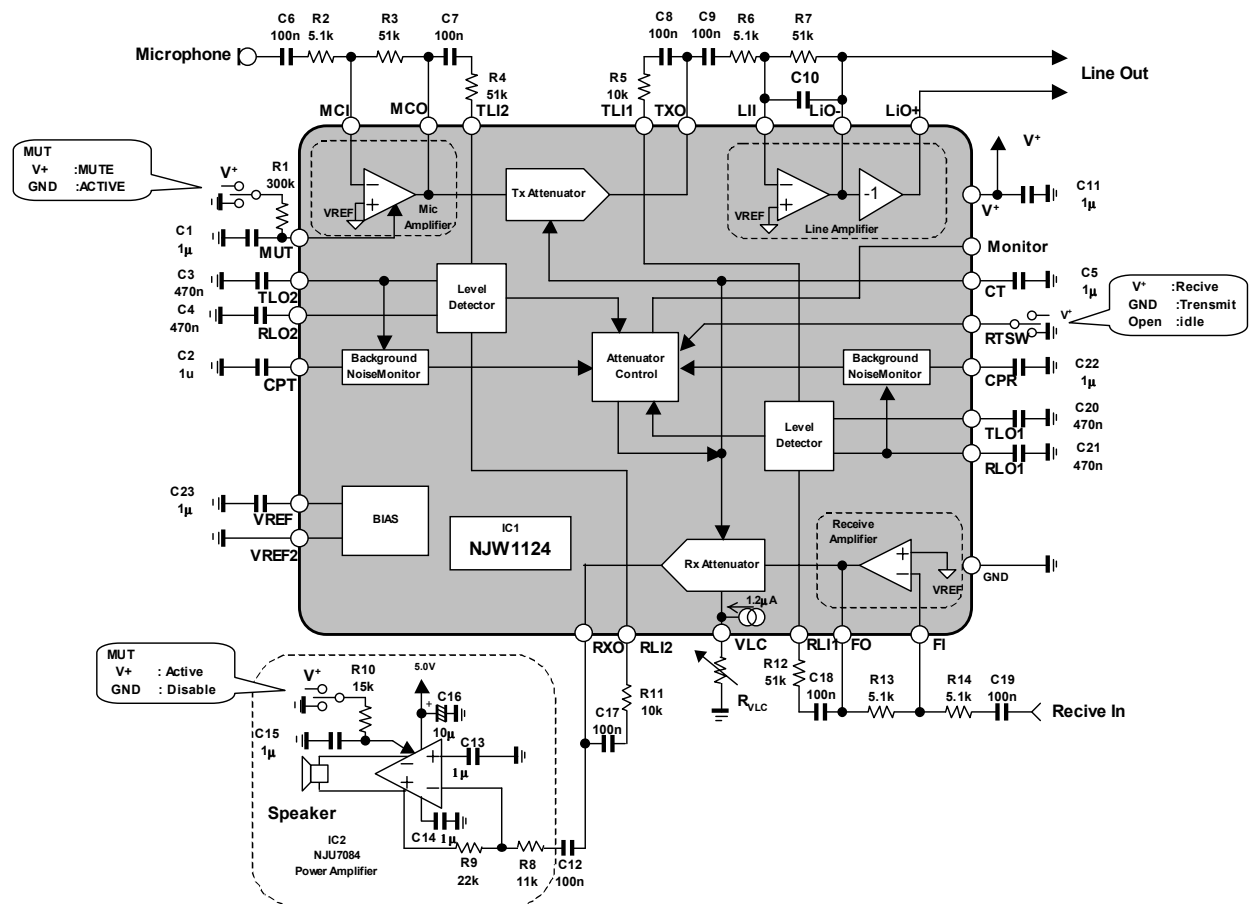

Fig.1 NJW1124 Block Diagram

The resistance and capacitor value above is just one example. Certain Half-duplex operation are not guaranteed. Best value depends on your microphone, speaker, and chassis. Especially, select capacitor value connected to V+(17pin) to be power supply ripple enough small (less than 5mVp-p). when 1μF is not enough, select larger value capacitor.

1. Receive Attenuator

Receive Attenuator has 3 modes depending on base and satellite unit condition.

PARAMETER	SYMBOL	TEST CONDITION	MIN.	TYP.	MAX.	UNIT
Receive Attenuator Gain 1	G_{R1}	RX-mode (Receive)	3.0	6.0	9.0	dB
Receive Attenuator Gain 2	G_{R2}	TX-mode (Transmit)	-43	-46	-50	dB
Receive Attenuator Gain 3	G_{R3}	Idle-mode (Standby), CPT=CPR=V ⁺	-17	-20	-23	dB

1. Receive Attenuator Gain 1 , (Receive mode :Gain=+6dB)
Condition: Receive signal from satellite unit, and no transmit signal to base unit.

2. Receive Attenuator Gain 2 , (Transmit mode :Gain=-46dB)
Condition: Transmit signal to base unit, and no receive signal from satellite unit.

3. Receive Attenuator Gain 3 , (Idle mode :Gain=-20dB)
Condition: Transmit signal to base unit, and no receive signal from satellite unit.

Volume Control

Receive Attenuator includes Volume Control.
Volume is controlled by resistor value connected to VCL pin.
Fig.2 shows Volume attenuate vs. Resister value.
Volume max.(0dB) : 0 Ω ,
Volume min. (-40dB): 100k Ω .

Transmit Attenuator doesn't equip Volume Control.

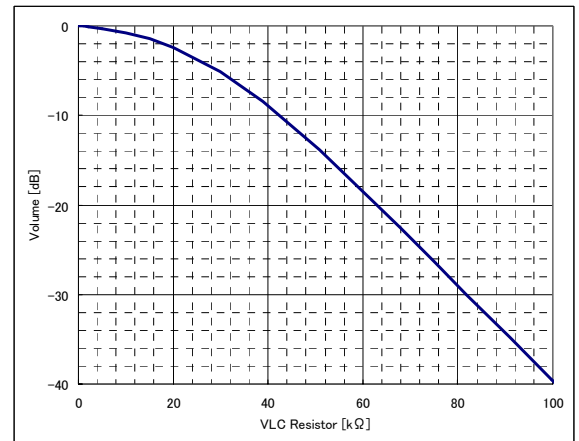

Fig.2 Volume vs. VCR Resister

2. Transmit Attenuator

Transmit Attenuator has 3 modes depending on base and satellite unit condition.

PARAMETER	SYMBOL	TEST CONDITION	MIN.	TYP.	MAX.	UNIT
Transmit Attenuator Gain 1	G_{T1}	RX-mode (Receive)	3.0	6.0	9.0	dB
Transmit Attenuator Gain 2	G_{T2}	TX-mode (Transmit)	-43	-46	-50	dB
Transmit Attenuator Gain 3	G_{T3}	Idle-mode (Standby), CPT=CPR= V^+	-17	-20	-23	dB

1. Transmit Attenuator Gain 1 , (Transmit mode :Gain=+6dB)
Condition: Receive signal from satellite unit, and no transmit signal to base unit.

2. Transmit Attenuator Gain 2 , (Transmit mode :Gain=-46dB)
Condition: Transmit signal to base unit, and no receive signal from satellite unit.

3. Transmit Attenuator Gain 3 , (Idle mode :Gain=-20dB)
Condition: Transmit signal to base unit, and no receive signal from satellite unit.

3. Microphone Amplifier

Microphone Amplifier is an operational Amplifier amplifying the signal from microphone to line level.

Fig.3 shows Block Diagram of Mic.Amp..

Non-inverting input keeps reference voltage inside. Mic.Amp is used as inverting amplifier. The Gain should be 40dB or less.

Mic.amp equips Mute function.

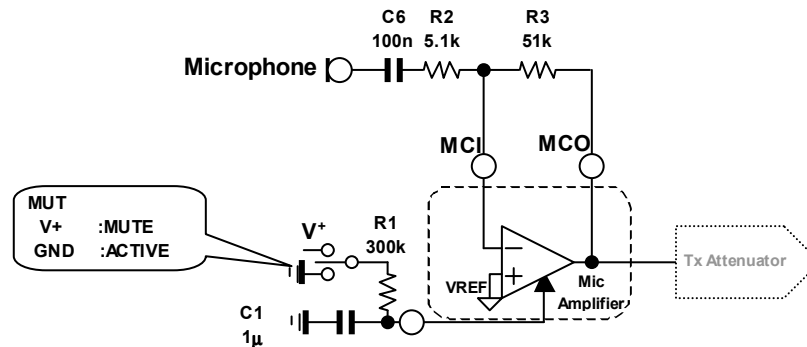

Fig.3 Mic.Amp Block.(20dB Application)

Outside parts	Function	recommend value	Detail	Memo
C6	DC decoupling	100nF ~ 10μF	-	Shape HPF : $f_c=1/(2\pi \times C6 \times R2)$
R2	Gain Setting	3kΩ ~ 300kΩ	Input impedance = R2	Recommend gain less than :40dB Large resistance value may cause oscillating.
R3				
R1	Pop noise reduction	100Ω ~ 300kΩ	The control voltage is made gradual with RC filter.	-
C1	100n ~ 10μF			

MUT(2pin) Input Voltage		Operation
V _{IH}	>1.5V	MICAMP MUTE
V _{IL}	<0.3V	MICAMP ACTIVE

4. Receive Amplifier

Receive Amplifier is an operational Amplifier receiving the signal from satellite unit.
 Fig.4 shows Block Diagram of Mic.Amp Block Non-inverting input keeps reference voltage inside.
 Receive Amp is used as inverting amplifier. The Gain should be 40dB or less.
 Receive Amplifier doesn't equip Mute function.

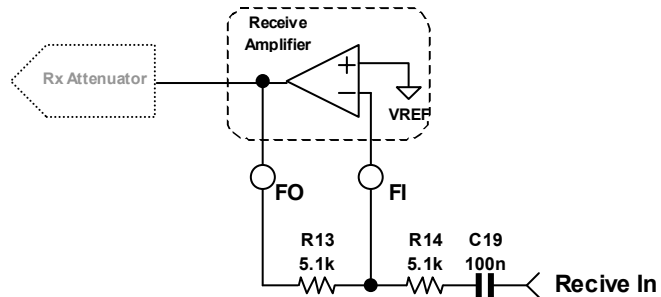

Fig.4 Receive.Amp Block.(0dB Application)

Outside parts	Function	recommend value	Detail	Memo
C19	DC decoupling	100nF ~ 10μF	-	Shape HPF : $f_c = 1 / (2\pi \times C19 \times R14)$
R14	Gain Setting	3kΩ ~ 300kΩ	$G_v = R13 / R14$	Recommend gain less than :40dB Large resistance value may cause oscillating.
R13			Input impedance = R14	

5. Line Amplifier

Line Amplifier transmits the signal from Tx attenuator to satellite unit. Line Amplifier consists of two operational Amplifiers.

First Amplifier non-inverting input keeps reference voltage inside. First Amplifier is used as inverting amplifier. Second Amplifier includes -1 fixed Gain.

These two amplifiers enable to differential output from single-ended signal.

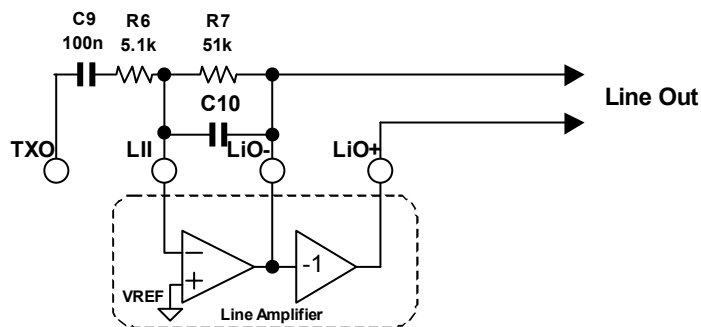

Fig.5 Line Amplifier Block(26dB Application)

Outside parts	Function	recommend value	Detail	Memo
C9	DC decoupling	100nF~10μF	-	Shape HPF : $f_c=1/(2\pi\times C9\times R6)$
R6	Gain Setting	3kΩ~300kΩ	$G_v=R7/R6$	Recommend gain less than :26dB Large resistance value may cause oscillating.
R7			Input impedance=R6	
C10	oscillation prevention	10p~100pF	-	Shape LPF : $f_c=1/(2\pi\times C10\times R7)$

Line Amplifier may oscillates, long transmission path becoming large capacitive load. In this case, add ceramic capacitor (47p to 100p) between LII and LIO-.

Add it as close as possible to the terminal. The frequency should be cut more than you need.

LIO+,LIO- should not be short to GND. LIO+,LIO- terminal are biased to $V+/2$).

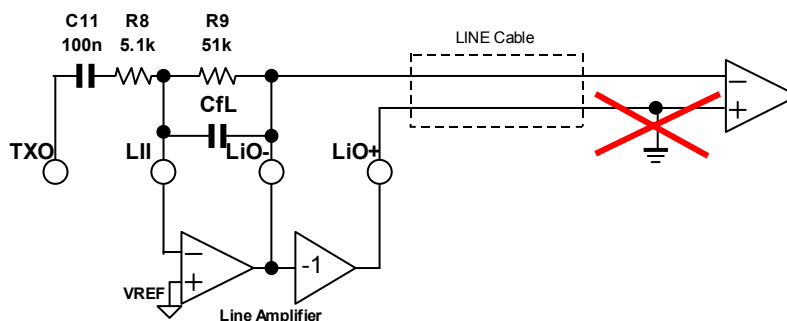

Fig.6 Forbidden Circuit.

6. Monitor Terminal

Monitor Terminal switches Voltage mode depending NJW1124 condition.

NJW1124 condition	Monitor Terminal Voltage
Receive mode	V+
Transmit mode	GND
Idle mode	Hi-Z or (V+/2)

7. Level Detector Block

The **NJW1124** includes Level Detector Block and Background Noise Monitor on transmit block and receive block. Level Detector Block consists of two same detectors.

Fig.7 shows Level Detector block.

The signal(S1 to S4) output each detector transmits to attenuator controller to change the mode. Next 7.1 and 7.2 explain about each detector and Background Noise Monitor operation details. About S1 to S4 signals, refer to 8 part.,

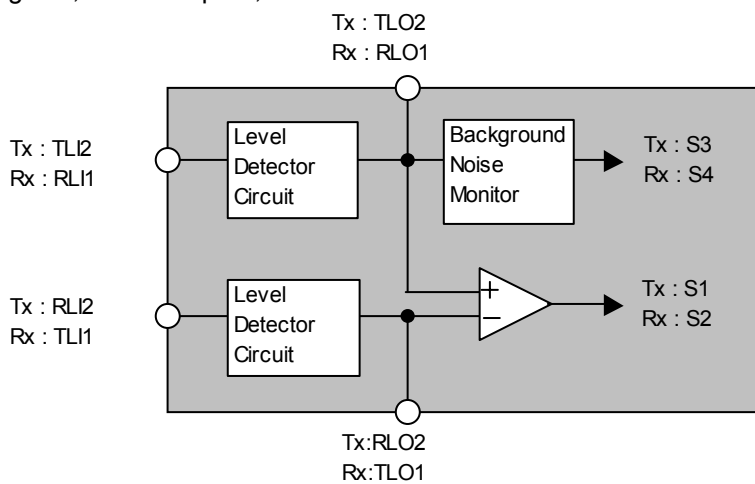

Fig.7 Level Detector Block

7.1 Level Detector Circuit

Fig.8 shows level detector circuit.

Level detector circuit includes logarithmic amplifier using diodes (D1,D2) to keep dynamic range.

The signals input to each level detector through external coupling capacitor C_i , are converted to current by input resistance R_{in} and input logarithmic amplifier through TLI2,1 and RLI1,2.

The current input changes diode(D1) current .

When the current more than $0.54\mu A$ (Current Source circuit) inputs ,diode D1 is off, and A point voltage drops.

In case of sinking current, the current increase D1 current, that increase A point voltage rises.

The point voltage is defined as follows.

$$\Delta V_A = 0.026 \times \ln \left[\frac{\{ I_{in} + (0.54 \times 10^{-6}) \}}{(0.54 \times 10^{-6})} \right]$$

$I_{in} = V_{in} / R_{in}$. (Actually, C_i effects)

The voltage A point goes through buffer Amplifier AMP2, charge the capacitor connected to TLO1,2,RLO1,2.

The charging completes immediately.

Response Example1 shows TLO2($C_o = C_5 = 0.1\mu F$) signal waveform outputting $200mV_{rms}/1kHz$ from MICOUT(MCO pin).

without input signal from TL1,TL2,RL1,and RL2, C_o releases current.

The Voltage Gradient is defined as follows:

$$\delta V_c = -0.3\mu A / C_o$$

Response Example 2 shows the signal response finishing input the signal.

Actual application being influenced on leak current and equivalent resistance in series,

δV_c does not accords with the formula completely. Check on the operation using actual capacitor

(Use high input impedance probe like FET Measuring instrument)

Small capacitor shortens the time to detect, and deteriorate the low frequency rectification characteristics. That influences on Noise Detector on next page.

Large capacitor improves rectification characteristics, and noise detector function.

However, extends the time to detect, it may judges the signal on noise.

Appropriate capacitor value depends on a application.

The input current TLI1,TLI2,RLI1,and RLI2 should be less than $100\mu A$ for normal operating .

Especially, gain mode has 9dB gain max, care of excessive input.

Voice switch circuit may malfunctions with Excessive input current

Fig.9 shows R_{in} (input impedance) vs. minimum input sensitivity of noise detector and maximum permissible voltage.

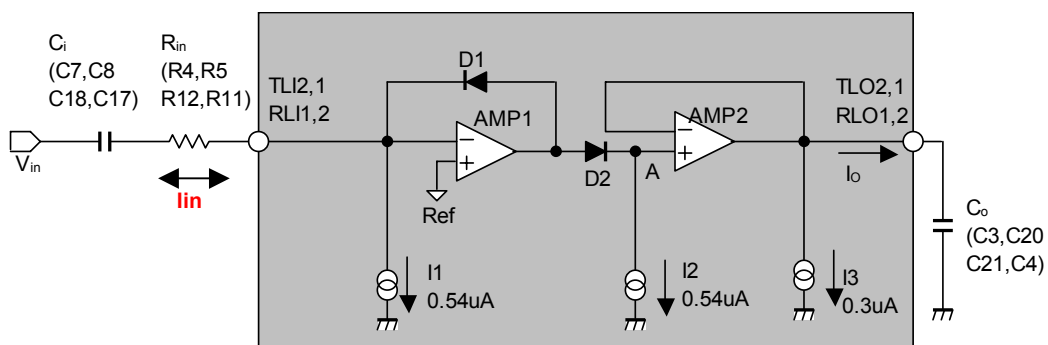
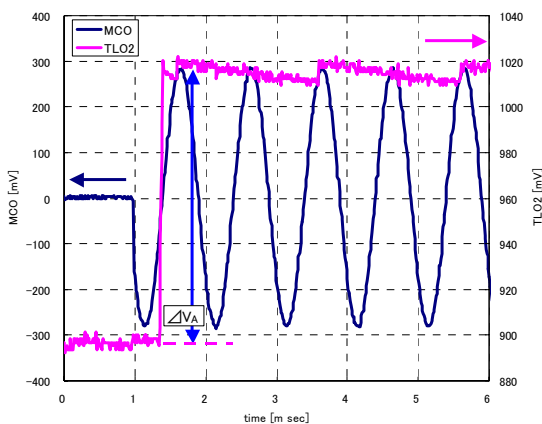
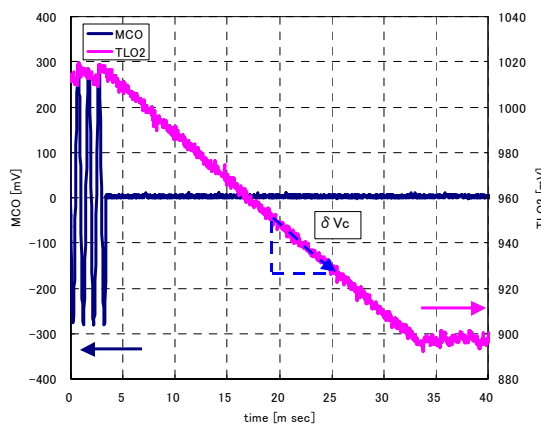

Fig.8 Level Detector Circuit Diagram

Outside parts	Function	recommend value	Detail	Memo
C_{in}	DC decoupling	$100nF \sim 1\mu F$	-	Shape HPF : $f_c = 1 / (2\pi \times C_{in} \times R_{in})$
R_{in}	V/I Convert	$5k\Omega \sim 100k\Omega$	$I_{in} = V_{in} / R_{in}$	Use " I_{in} " by $100mA$ or less.
C_o	Detection level keeping	$0.05\mu F \sim 1.0mF$	$\delta V_c = -0.3\mu A / C_o$	Use the capacitor leaking a little. Small capacitor deteriorate the low frequency rectification characteristics .



Response example.1
MCO vs. TLO2signal (starting input)
MCO = 200mVrms/1kHz C5 = 0.1μF



Response example.2
MCO vs. TLO2signal (finishing input)
MCO = 200mVrms/1kHz C5 = 0.1μF

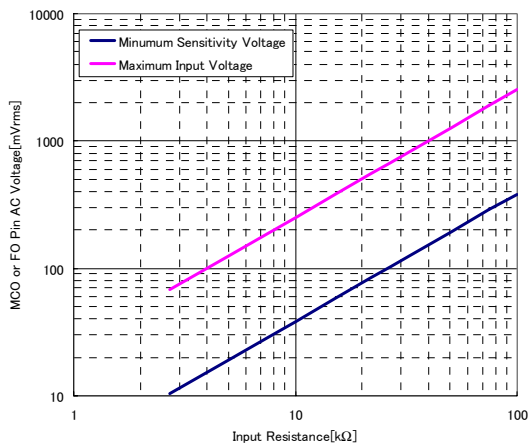

Fig.9 Minimum Input Voltage vs. Input Resistance
(R4 or R12 Theoretical Value resistance
R4=R5,R12=R11 condition)

Maximum Input Voltage(V_{in} (Fig.8)), which equal to MCO or FO Maximum Output Voltage

Minimum Input Voltage(sensitivity), which is the Voltage shifting mode(idle to receive, idle to transmit).

Note: Maximum Voltage is defined by the smaller resistor, 35% value of R5, R11 or R4, R11 value.

7.2 Background Noise Monitor

Background Noise Monitor judges whether the input signal is noise or sound or voice by TLO2 and RLO2 voltage, and change the mode.

The **NJW1124** includes the Background noise monitor on transmit side and receive side.

Fig.10 shows Block diagram of Background noise monitor.

The voltage difference between TLO2 or RLO1 and Ref is amplified 8.6dB on AMP1.

The signal from AMP1 inputs 2nd stage AMP2 and comparator (COMP).

The COMP non-inverting input voltage becoming 36mV higher than inverting, COMP output 1, which shows the **NJW1124** is transmit or receive mode.

At the same time, external capacitor charged from 0.8μA internal current source, until the C_{CP} voltage becomes 46mV higher than AMP2 input voltage.

The equivalent below shows C_{CP} voltage charging.

$$\Delta V_{CP} = 0.8\mu A / C_{CP}$$

For example, C_{CP}=1μF, δV_{CP}=0.8V/sec.

Without the input signal, C_{CP} discharged and finally reset the Background noise monitor.

Response example is ex.3.

The signal like continued sign wave inputting, COMP output '0' which is noise-monitoring mode (idle-mode).

The signal like conversation sound inputting, C_{CP} continues to charge and discharge. COMP output continued to '1', which is transmit or receive mode.

Small C_{CP} shortens the time shifting to '0' condition. Too small C_{CP} attenuates even the conversation signal.

Large C_{CP} keeps '1' condition long, which lengthen attenuating time.

Capacitor should be adjusted appropriately on actual application.

(Use high input impedance like FET probe measuring voltage of CPT, CPR pin.)

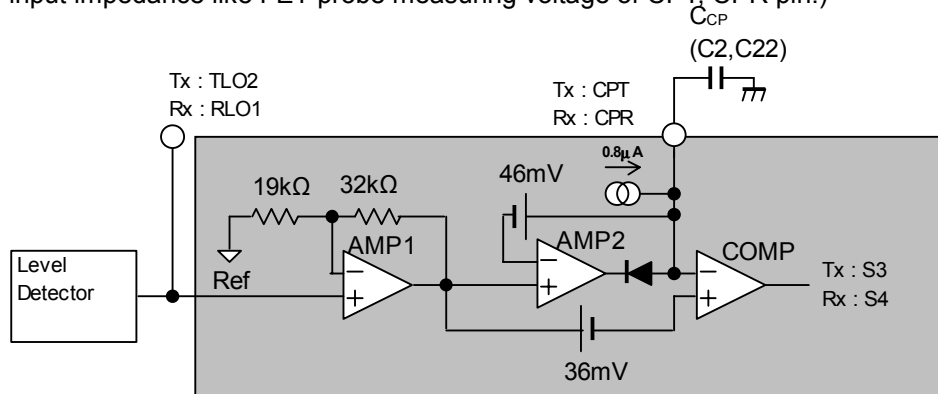
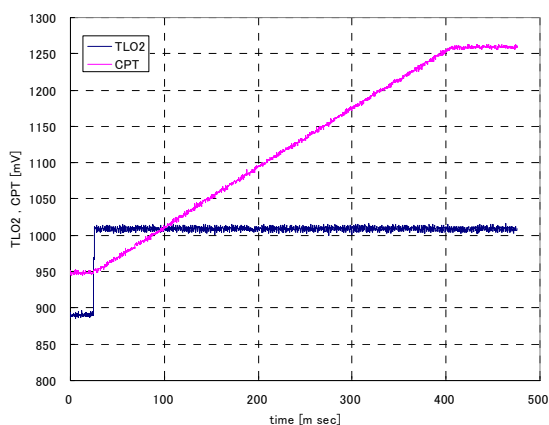
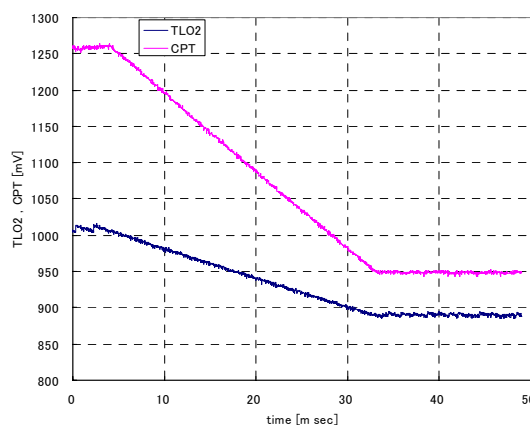

Fig.8 Background Noise Monitor Block Diagram

Function	recommendation value	Detail	Memo
Noise Detection	100nF ~ 1μF	-	The time for noise detection depends on this.



Response example.3
TLO2 vs. CPT signal (input start)
MCO = 200mVrms/1kHz
C5 = 0.1μF, C4=1μF



Response example.4
TLO2 vs. CPT signal (input finish)
MCO = 200mVrms/1kHz
C5 = 0.1μF, C4=1μF

8. Attenuator Controller

Attenuator Controller controls each mode (Transmit or Receive or idle) by the signal (S1 to S4) from level detector according as table.1 below

Table.1 shows truth table (On RTSW=Open).

Internal 12μA current source circuit charges and discharges C7, connected with CT pin

On the mode changing condition, δV_{C5} shows voltage change according as the formula below. .

$$\delta V_{C7} = \pm 12\mu A / C_5 \quad (11.1) \quad (C7 \text{ is } C5 \text{ capacitance connected to CT pin.})$$

on initial state, CT pin voltage equals to Vref voltage. Shifting to transmit mode, C7 discharges and become lower voltage than Vref voltage. Example 5 and 6 shows behaviors. V_{CT} voltage is CT voltage minus Vref voltage.

On receive mode, internal current source charging C_5 raises CT voltage.

CT pin voltage shows operating condition (Transmit or Receive or idle).

(more than 100MΩ impedance probe should be monitoring the voltage.

'FAST idle mode' enables to shift promptly charging C7 rapidly.

On 'SLOW idle mode', mode shifts gently.

Both time constants τ are below:

$$\tau = R_{AX} C_5$$

(R_{AX} is $R_{A1} R_{A2}$ resistance. After τ sec, The voltage is attenuated to 1/e default value)

For example, $C7=1\mu F$, $\tau=600m$ sec.

attenuator gain G_{AT} estimate as below:

$$G_{AT(TX)} = 0.1 \times \exp \{ -V_{CT} / 0.026 \} \quad \text{on transmit mode} \quad (11.3)$$

$$G_{AT(RX)} = 0.1 \times \exp \{ V_{CT} / 0.026 \} \quad \text{on receive mode} \quad (11.4)$$

$C_5 = 1\mu F$, attenuator time constant on SLOW idle mode is about 225m sec.

Table.6 as below shows response of transmit signal wave:

Fig.11 shows V_{CT} vs. G_{AT} .

Adjust this order for appropriate operating:

1. Resistance connecting to TLI1.2 and RLI1.2
2. Capacitor connecting to TLO1.2 and RLO1.2
3. Capacitor connecting CPT, CPR.

When adjusting above doesn't enable to appropriate operating (attenuating too fast or shifting too slow etc.), adjust C_5 value connecting to CT pin. Typical value is 1μF.

Table.1 Truth Table

S1	S2	S3	S4	Mode
Tx	Tx	1	X	Tx Mode
Tx	Rx	y	y	FAST Idle Mode
Rx	Tx	y	y	FAST Idle Mode
Rx	Rx	X	1	Rx Mode
Tx	Tx	0	X	SLOW Idle Mode
Tx	Rx	0	0	SLOW Idle Mode
Rx	Tx	0	0	SLOW Idle Mode
RX	Rx	X	0	SLOW Idle Mode

S1 : Result comparing RLO2 and TLO2
(RLI2 and TLI2 ●●●Detecting Base Unit side)
RLO2>TLO2 [Rx]
TLO2>RLO2 [Tx]

S2 : Result comparing RLO1 and TLO1
(RLI1 and TLI1 ●●●Detecting Satellite Unit side)
RLO1>TLO1 [Rx]
TLO1>RLO1 [Tx]

S3 & S4 : Output Background Noise Monitor
[1]: Detecting signal
[0]: Judging noise
[x]: Don't Care
[y]: Both C3 and C4 is not 0.

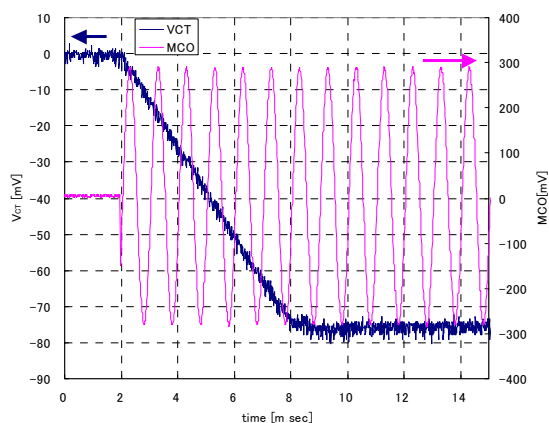

Response example.5
MCO vs. CT-VREF signal (input start)
MCO = 200mVrms/1kHz
C7=1 μ F

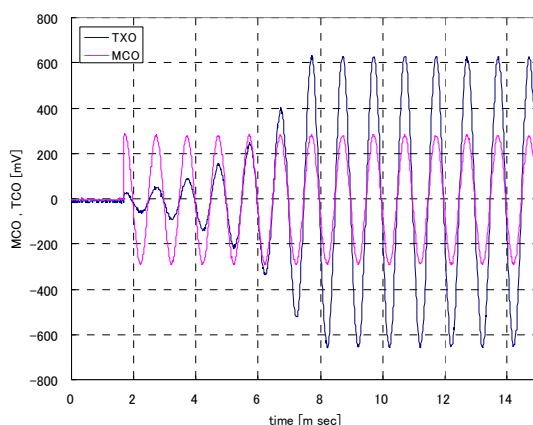

Response example.6
MCO vs. TXO(AC) signal (input start)
MCO = 200mVrms/1kHz C7=1 μ F

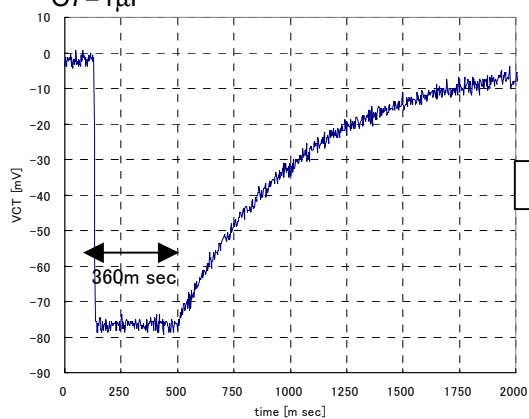

Response example.7
CT-VREF signal (input continue)
MCO = 200mVrms/1kHz C7=1 μ F
SLOW idle mode

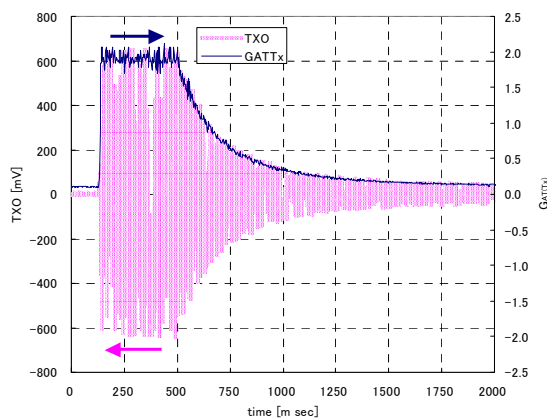

Response example.8
G_{AT} vs. TCO signal (input start)
MCO = 200mVrms/1kHz C7=1 μ F
SLOW idle mode

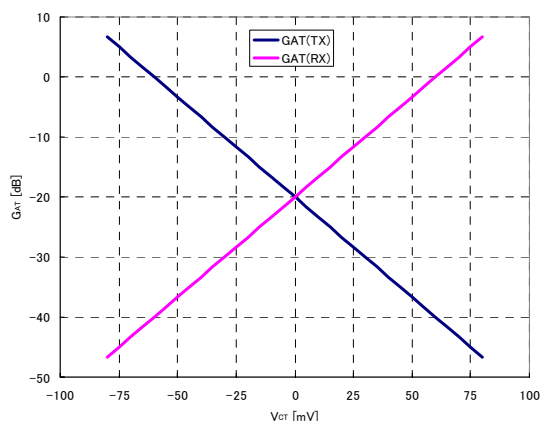
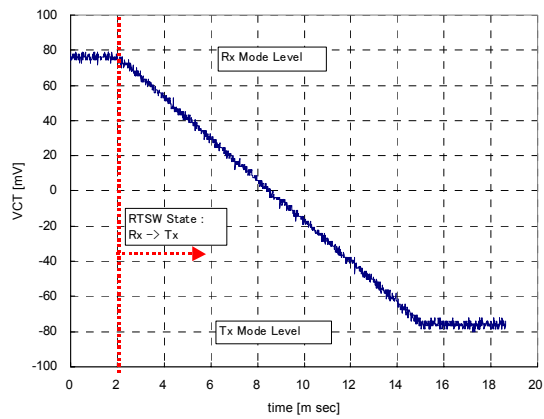

Fig.11 G_{AT} vs. V_{CT} Calculated Spectrum

RTSW shifts the mode forcibly. RTSW changes the CTpin voltage forcibly to shift the mode.
Ex.9 shows the response to RTSW.



Response example.9
RTSW shifting (Receive mode to Transmit mode)
C7=1 μ F

10. Acoustic Coupling Reduction

To reduce Acoustic Coupling, isolating speaker and microphone is effective. Adjusting resistance value connected to TLI1, TLI2, (R4, R5, R11) and RLI1 is also effective, For example, configure R12,R4 value is 2 to 6 times than R5,R11. Reducing sensitivity to echo enables to operate normally.

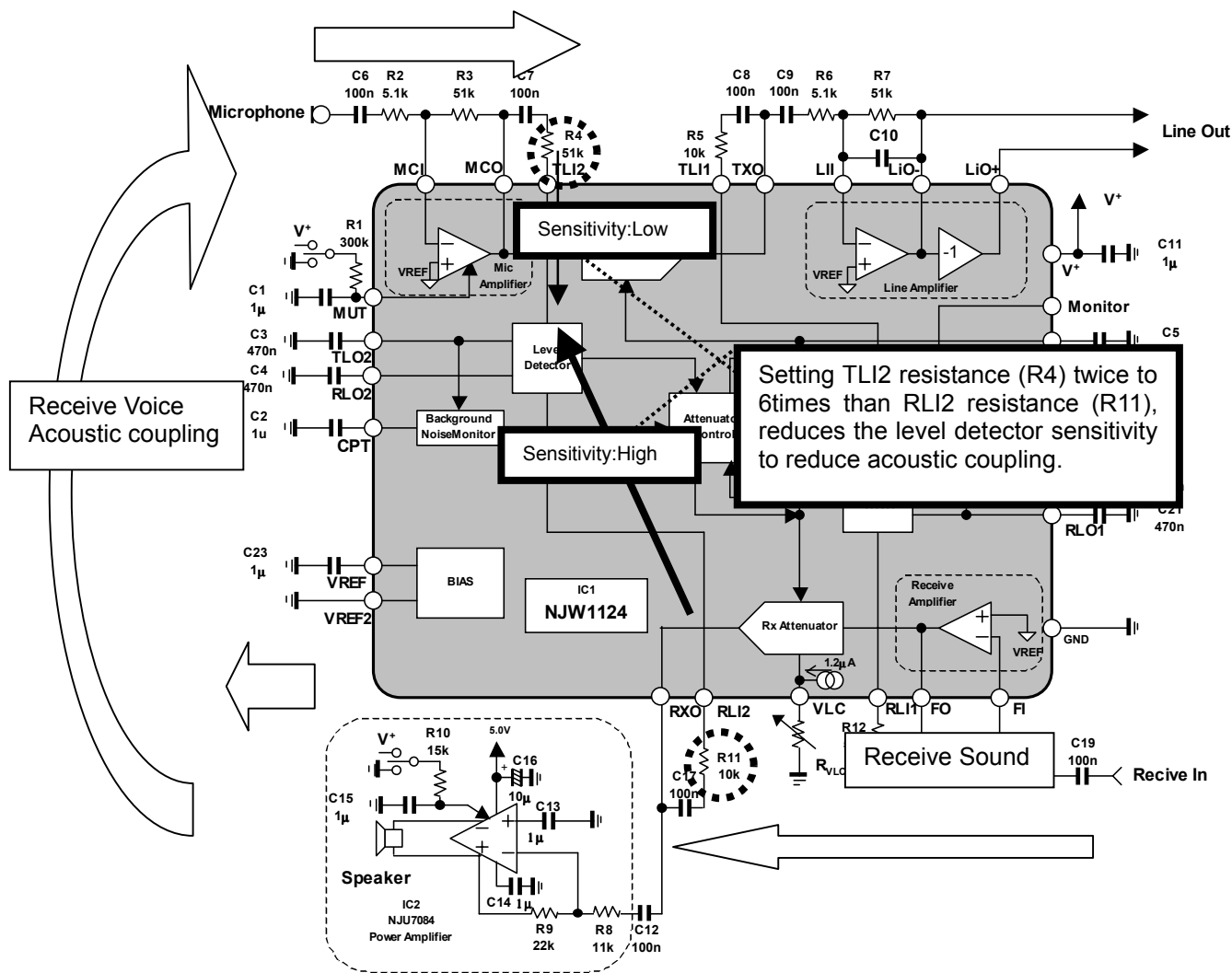

Fig.12 Acoustic Coupling Reduction

Reducing the sensitivity of R4,R12 reduces the time shifting to noise mode. In case of too fast shifting, enlarge capacitor connected to CPT,CPR.

Notes:1**To reduce Pop-Noise of power-on and off.**

Appropriate power supply sequence reduces pop-noise.

Initial condition: No power supply.

CD switch of Speaker Amplifier should be standby condition.

The circuit connected to Line out and Receive In is off.

Power-on sequence

- 1.Power-on NJW1124. Concurrently The circuit connected to Receive In power on.
- 2.After 1 sec later, the circuit connected to Line OUT and Speaker Amplifier IC power on.
- 3.After 1 sec later, Speaker Amplifier IC shifts active mode.

Power-off sequence

- 1.Speaker Amplifier shift standby mode.
- 2.After 1 sec later, the circuit connected to Line OUT and Speaker Amplifier power off.
- 3.After 1 sec later, NJW1124 power off. Concurrently, the circuit connected to Receive In power off.

Notes:2:

Filter circuit using Receive amplifier, Mic. Amplifier, Line amplifier.

Receive amplifier, Mic. Amplifier, Line amplifier enable to form active filter circuit which is 1st order or 2nd order, HPF or LPF or BPF.

1.1st order HPF,LPF circuit example

Fig.13 shows 1st order (-6dB/oct) HPF, LPF circuit.

Combining HPF formed by Co and R1, and LPF formed by C1 and R2, forms BPF.

(Co should be also used typical application as DC decoupling.)

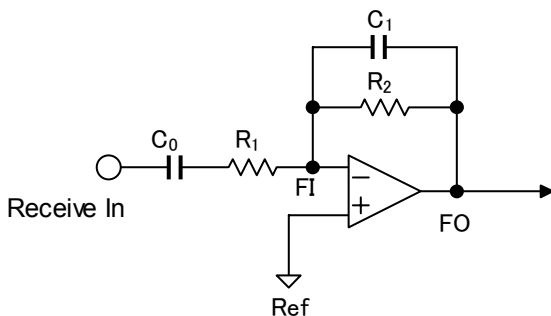
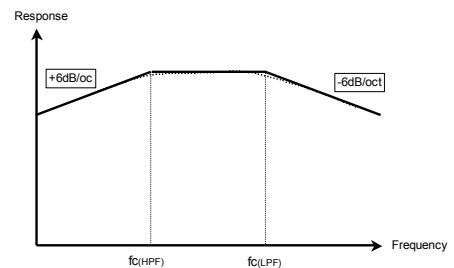

Fig.13 1st order HPF,LPF circuit example

$$f_{C(HPF)} = \frac{1}{2\pi C_0 R_1}$$

$$f_{C(LPF)} = \frac{1}{2\pi C_1 R_2}$$



2.2nd order LPF circuit example

Fig.14 shows 1st order (-12dB/oct) LPF circuit.

Same as 1st order filter, Co should be used as DC decoupling. C2 selecting arbitrarily, Butterworth filter forming coefficient is as below.

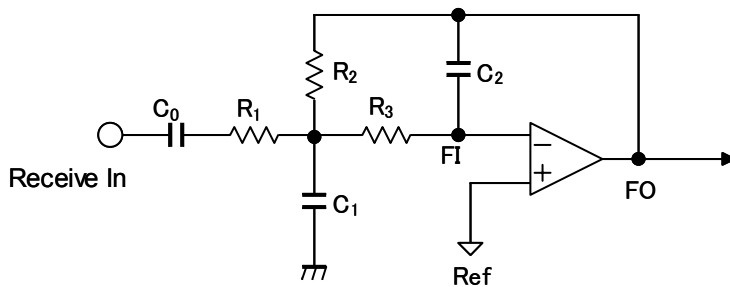

Fig.14 2nd order LPF circuit example

$$R_1 = \frac{1}{2\sqrt{2}G\pi f_{C(LPF)} C_2}$$

$$R_2 = \frac{1}{2\sqrt{2}\pi f_{C(LPF)} C_2}$$

$$R_3 = \frac{1}{2\sqrt{2}(G+1)\pi f_{C(LPF)} C_2}$$

$$C_3 = 2(G+1)C_2$$

G = Gain

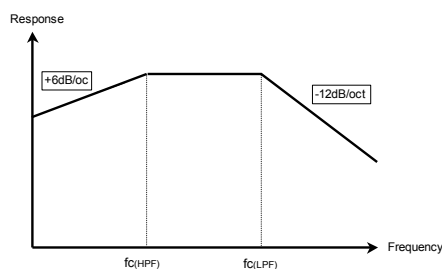

$f_{C(HPF)}$ is same as 1st order type above.

Fig.15 shows 2nd order LPF(Gain=20dB, $f_{c(LPF)} = 4\text{kHz}$) circuit example.

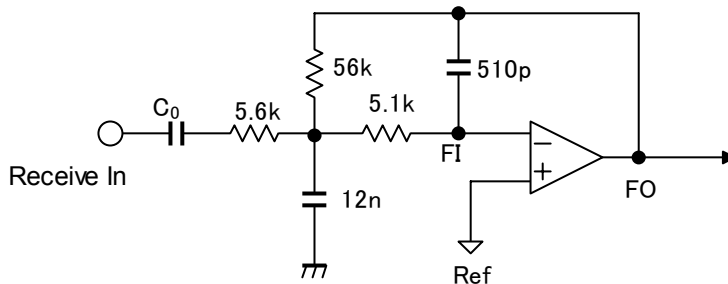

Fig.15 2nd order LPF(Gain=20dB, $f_{c(LPF)} = 4\text{kHz}$, Butterworth filter) circuit example.

3.2nd order HPF circuit example

Fig.16 shows 2st order (-12dB/oct) HPF circuit.
 $C_0=C_2$, Butterworth filter forming coefficient is as below.

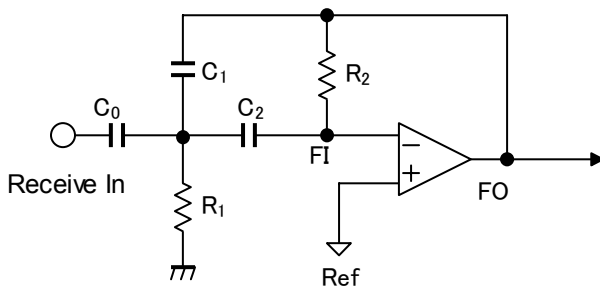

Fig.16 2nd order HPF circuit example.

$$R_1 = \frac{\sqrt{2}}{2\pi f_{C(HPF)} C_0 (2 + 1/G)}$$

$$R_2 = \frac{2G + 1}{2\pi f_{C(HPF)} C_0}$$

$$C_1 = \frac{C_0}{G}$$

* $C_0 = C_2$

Fig.17 shows HPF(Gain=20dB, $F_{c(HPF)}=200\text{Hz}$) circuit example.

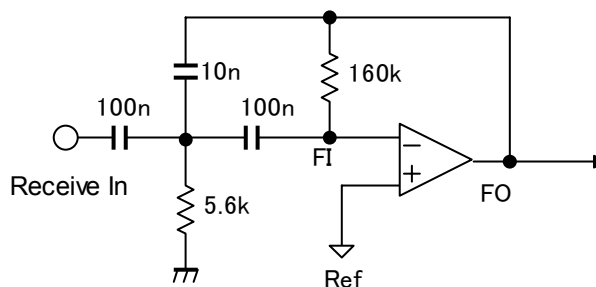

Fig.17 2nd order HPF circuit example.
 Gain=20dB, $F_{c(HPF)}=200\text{Hz}$, Butterworth filter

Notes:3 list of Parts of Attenuator controller

Terminal	Parts	Recommend Value	Notes
Cin	C7,C8,C17,C1	100nF~1μF	The input capacitor forms HPF with Rin.
Rin	R4,R5,R11,R1	5.1k~51kΩ	V-I converter,which depends on sensitivity of each level detectors and noise detector. Smaller value lower detection level. Larger value raise detection level. Input voltage should be less than 100mA(200μA @25°C).
Co	C4,C5,C20,C2	0.05μF~1μF	The capacitor keeps voltage level.Larger value extends swiching time.Smaller value shortens swiching time, and deteriorate rectification property that adverse affects back ground noise monitor on low frequency signal.
Ccp	C2,C22	100nF~1μF	The capacitor judges whether the signal is noise.Larger value extends the judging time.Smaller value shortens the judging time.
Cct	C5	1μF	The capacitor generates the voltage controlling attenuater. Larger value extends attenuating time on switching and idle mode.Smaller value shortens the attenuating time.Please be careful of conduction caused by condensation due to this terminal is high impedance.Attenuater gain may be fluctuant .

[CAUTION]
 The specifications on this databook are only given for information , without any guarantee as regards either mistakes or omissions. The application circuits in this databook are described only to show representative usages of the product and not intended for the guarantee or permission of any right including the industrial rights.