



TAI-SAW TECHNOLOGY CO., LTD.

No. 3, Industrial 2nd Rd., Ping-Chen Industrial District,
Taoyuan, 324, Taiwan, R.O.C.

TEL: 886-3-4690038 FAX: 886-3-4697532

E-mail: tstsales@mail.taisaw.com Web: www.taisaw.com

Approval Sheet For Product Specification

Issued Date: Apr, 20, 2007

Product Name: SAW Filter 923.5 MHz SMD 3.0X3.0 mm

TST Parts No.: TA0644A

Customer Parts No.: _____

| |
|---------------------|
| Company: _____ |
| Division: _____ |
| Approved by : _____ |
| Date: _____ |

Checked by: _____ Bob Chau

Approval by: _____ Francis Chen

Date: _____ 4, 20, 2007



TAI-SAW TECHNOLOGY CO., LTD.

No. 3, Industrial 2nd Rd., Ping-Chen Industrial District,
Taoyuan, 324, Taiwan, R.O.C.

TEL: 886-3-4690038 FAX: 886-3-4697532

E-mail: tstsales@mail.taisaw.com Web: www.taisaw.com

SAW Filter 923.5MHz

MODEL NO.:TA0644A

REV. NO.:1

A. MAXIMUM RATING:

1. Input Power Level: 10 dBm
2. DC Voltage : 3V
3. Operating Temperature: -10°C to +85°C
4. Storage Temperature: -30°C to +85°C

RoHS Compliant
Lead free
Lead-free soldering

B. ELECTRICAL CHARACTERISTICS:

| Item | Unit | Min. | Type. | Max. | Note |
|--|------|------|-------|------|------|
| Center Frequency Fc | MHz | - | 923.5 | - | - |
| Insertion Loss (919 ~ 928 MHz) IL | dB | - | 2.6 | 3.5 | - |
| Amplitude Ripple (919 ~ 928 MHz) | dB | - | 0.6 | 3 | - |
| VSWR (919 ~ 928 MHz) | | - | 1.3 | 2.2 | - |
| Attenuation (Reference level from 0 dB) | | | | | |
| D.C ~ 880 MHz | dB | 30 | 53 | - | - |
| 880 ~ 900 MHz | dB | 20 | 50 | - | - |
| 900 ~ 910 MHz | dB | 10 | 24 | - | - |
| 940 ~ 1000 MHz | dB | 10 | 34 | - | - |
| 1000 ~ 3000 MHz | dB | 20 | 31 | - | - |

C. MEASUREMENT CIRCUIT:

HP Network analyzer

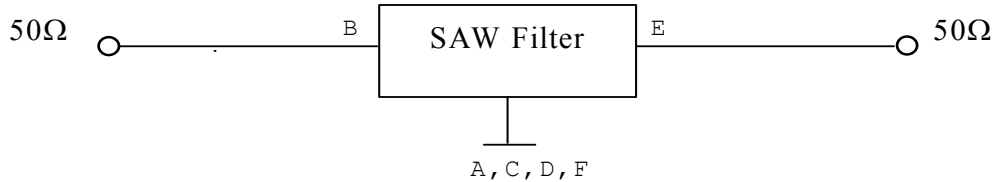

D.OUTLINE DRAWING:

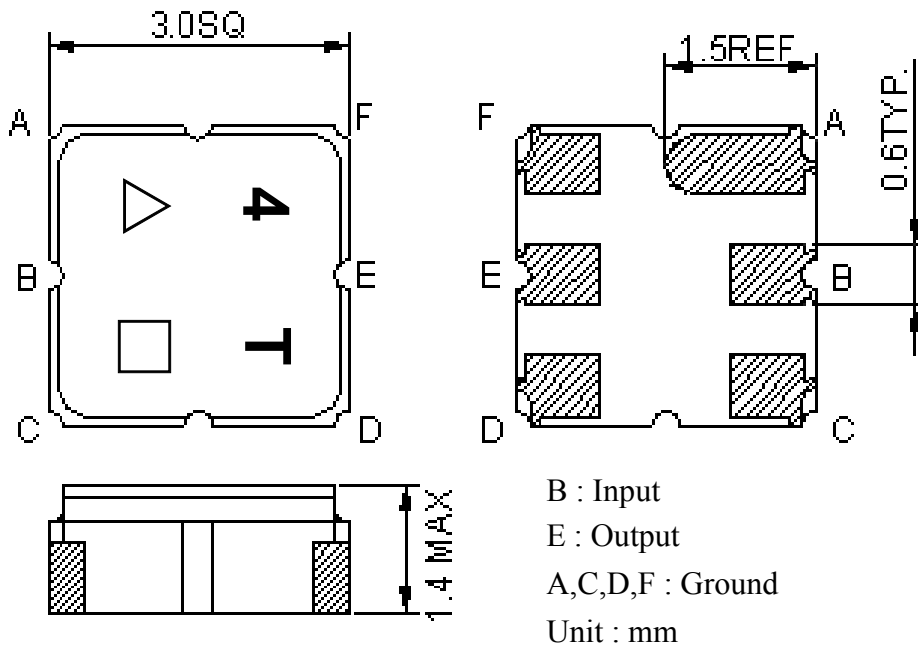

△ : Year Code (2006->6, ..., 2009->9)

□ : Date Code (Follow the table from planner each year)

E. PCB Footprint:

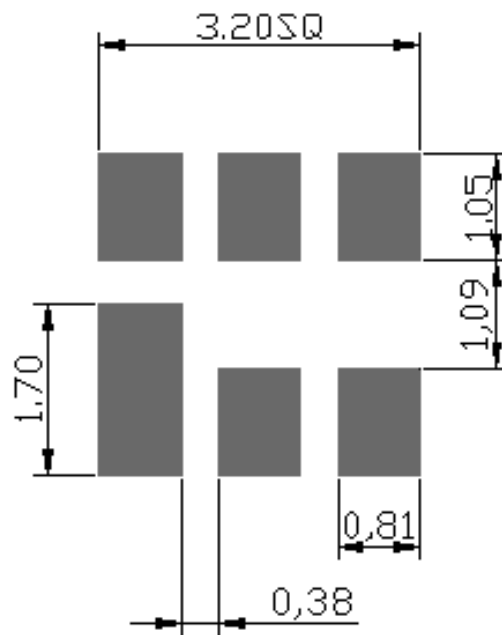

F. Frequency Characteristics :

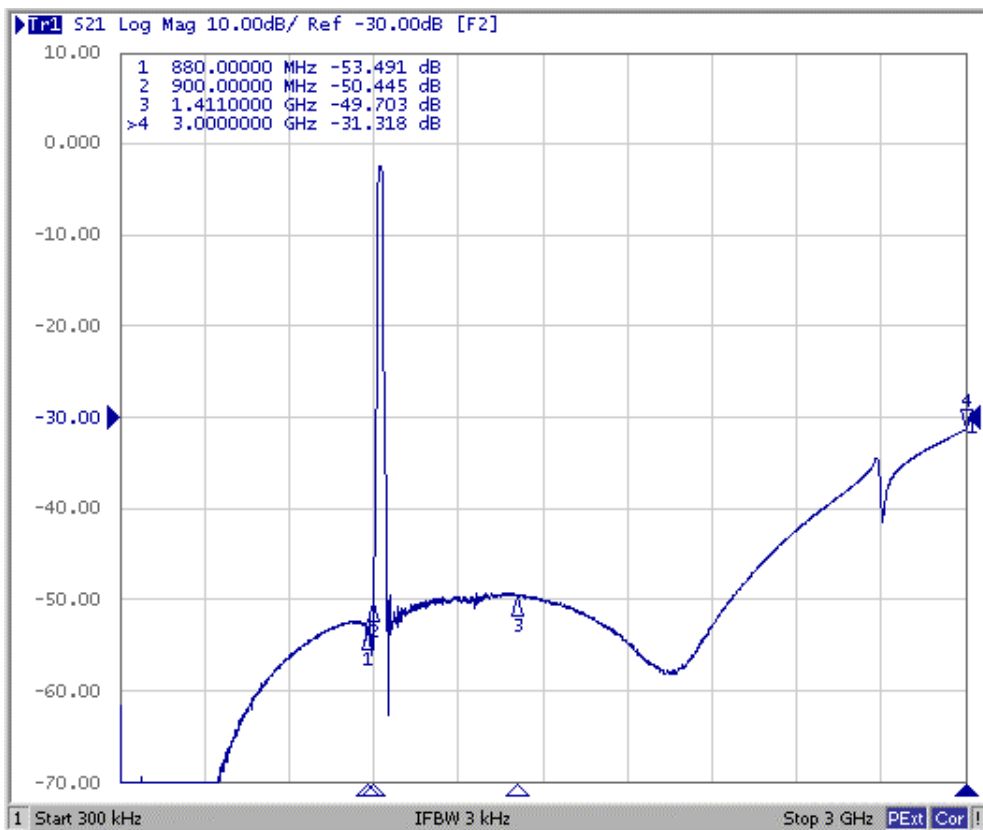
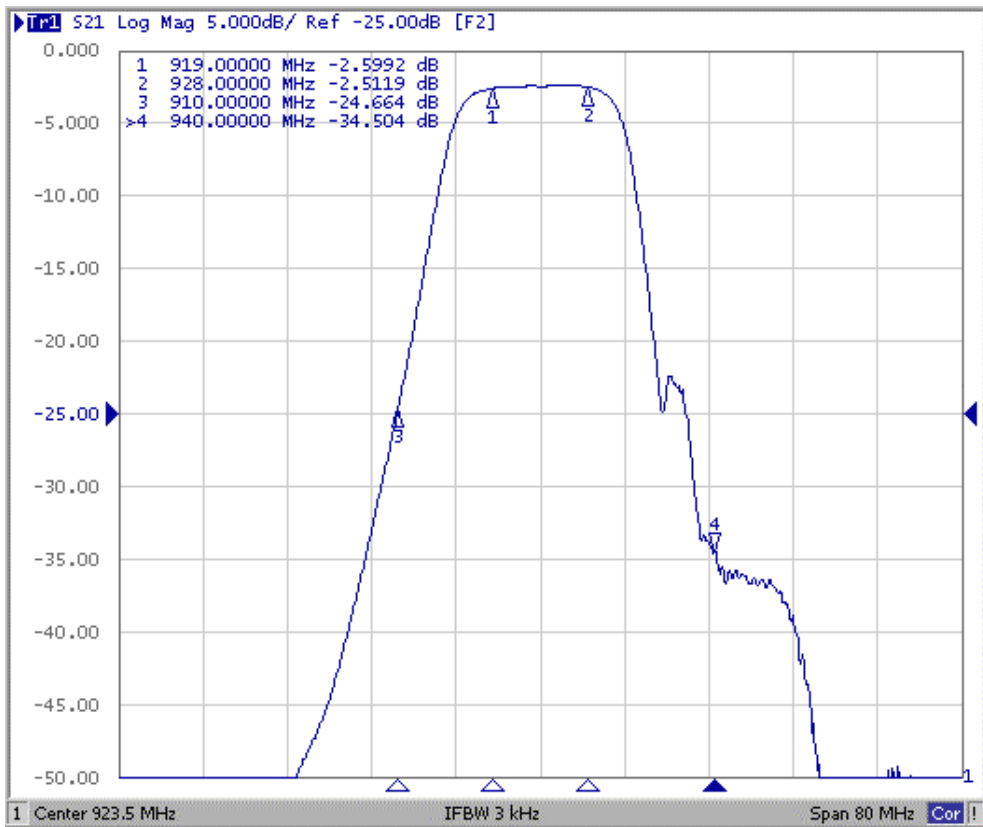

Reflection Functions :

S11

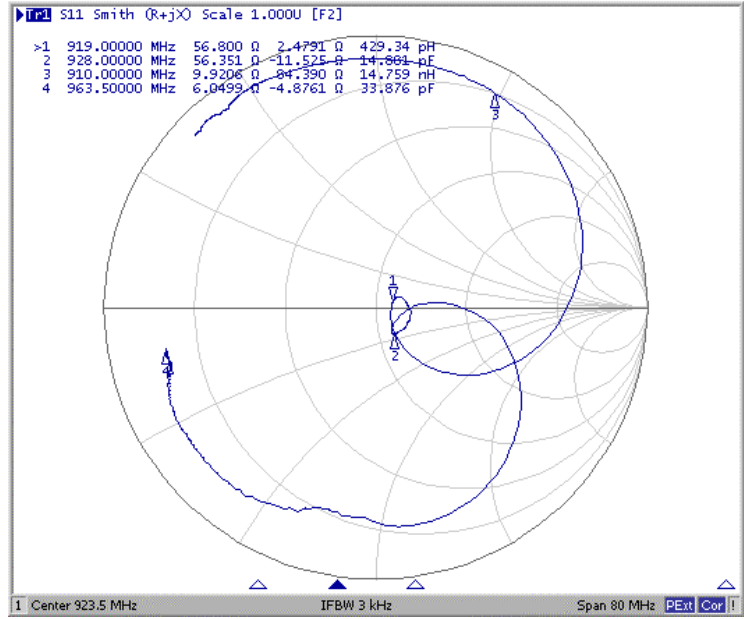
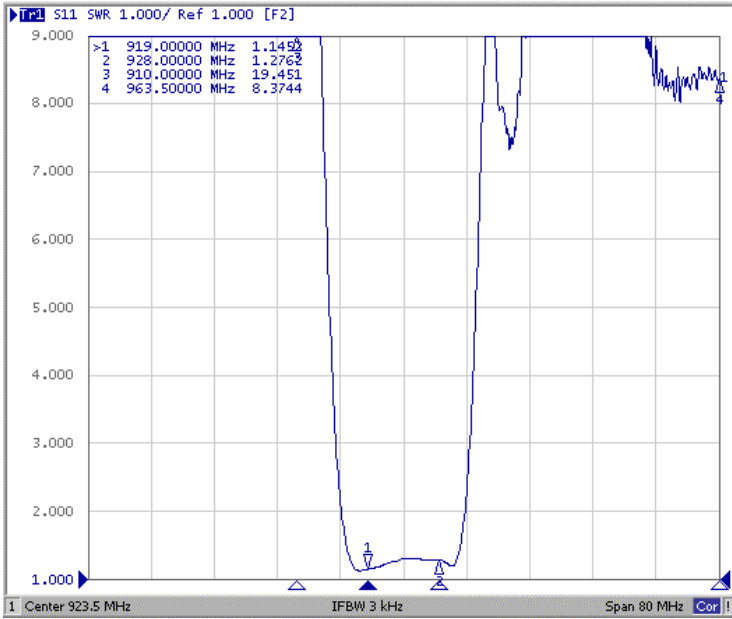

S22

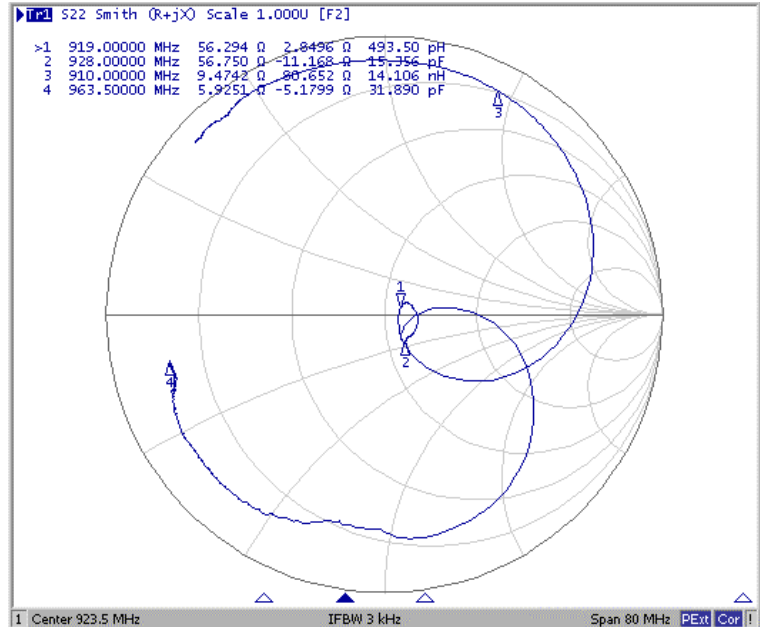
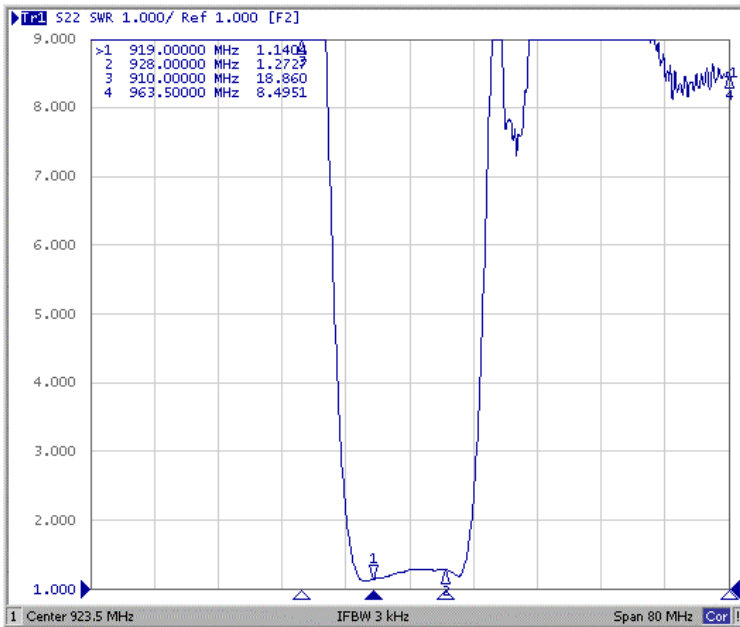

G. PACKING:

1. REEL DIMENSION

(Reel Count : 7''=1000 ; 13''=3000)

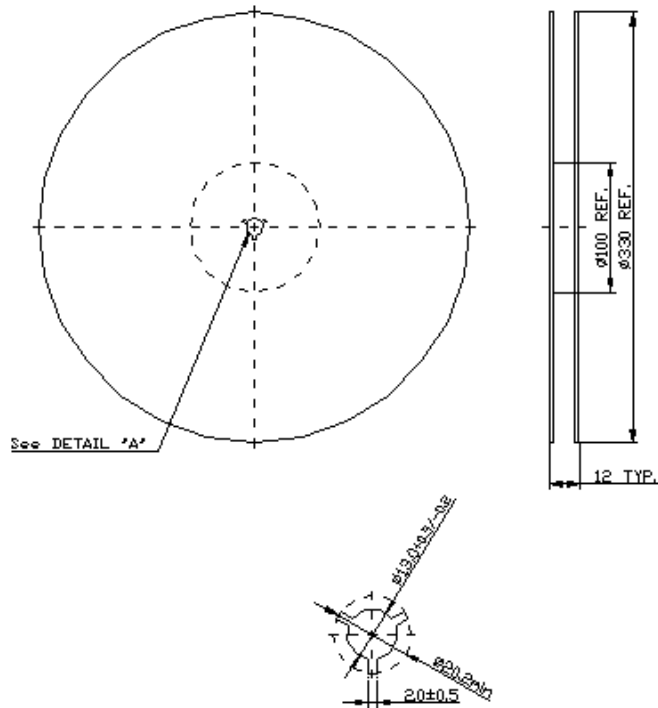

2.TAPE DIMENSION

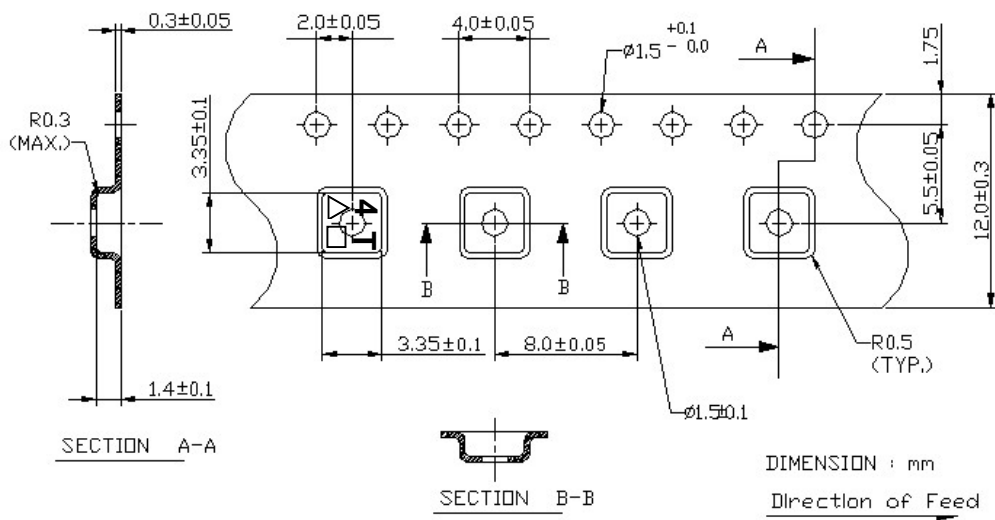

H. RECOMMENDED REFLOW PROFILE :

