

AM-145 / AMC-145



High Performance Amplifier,
11 dB Gain, 10 - 1000 MHz

Rev. V4

Features

- 2.5 dB Typical Midband Noise Figure
- +19 dBm Typical Midband Output Power
- +37 dBm Typical Midband Third Order Intercept

Description

M/A-COM's AM-145 is a coupler feedback amplifier with high intercept and compression points. The use of coupler feedback minimizes noise figure and current in a high intercept amplifier. This amplifier is packaged in a TO-8 package. Due to the internal power dissipation the thermal rise minimized. The ground plane on the PC board should be configured to remove heat from under the package. AM-145 are ideally suited for use where a high intercept, high reliability amplifier is required.

Ordering Information

Part Number	Package
AM-145 PIN ³	TO-8-1
AMC-145 SMA	Connectorized

3. Mounting kit part number AU00071 required for PCB applications.

Absolute Maximum Ratings¹

Parameter	Absolute Maximum
Max. Input Power	+10 dBm
Vbias	+15.75 V
Operating Temperature	-55°C to +85°C
Storage Temperature	-65°C to +125°C

1. Operation of this device above any one of these parameters may cause permanent damage.

TO-8-1

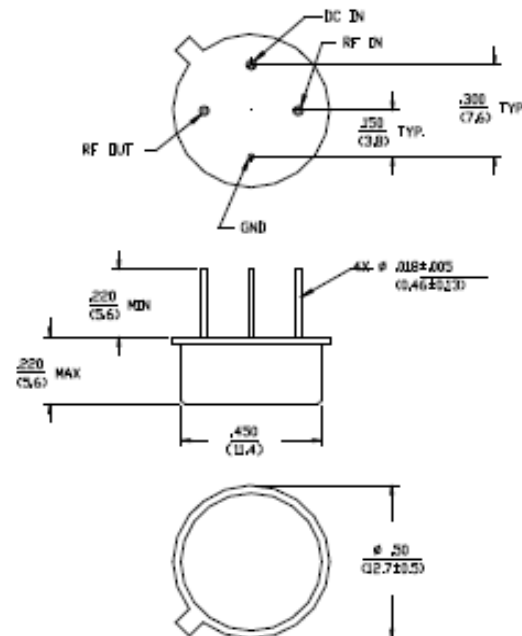

Dimensions in Circle in mm
Unless Otherwise Noted .XXX = ±0.010 CXX = ±0.25
.XX = ±0.02 (X = ±0.5)
WEIGHT (APPROX) (10) DUNCES 2.0 GRAMS

Outline Drawing: SMA Connectorized^{*}

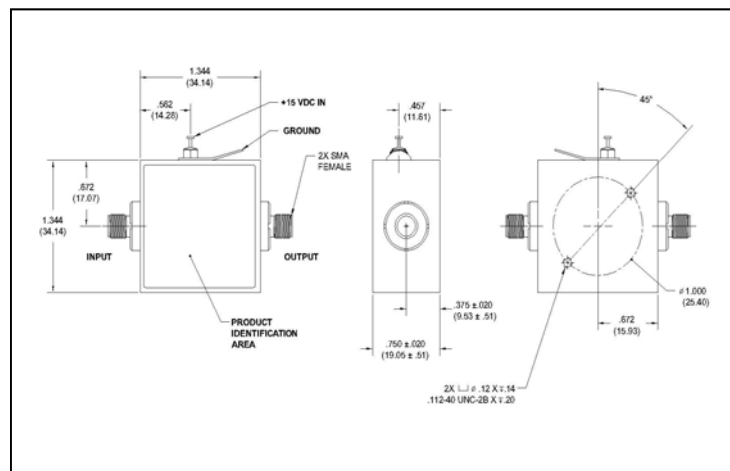

* Dimensions are inches (millimeters) ±0.015 (0.38) unless otherwise specified.

AM-145 / AMC-145



High Performance Amplifier,
11 dB Gain, 10 - 1000 MHz

Rev. V4

Electrical Specifications: ^{2,3} T_A = -55°C to +85°C Case Temperature

Parameter	Test Conditions	Frequency	Units	Min.	Typ.	Max.
Gain	@+25°C	300 MHz	dB	10.1	10.7	11.3
Frequency Response	—	10 - 1000 MHz	dB	—	—	±1.0
Gain Variation with Temperature	—	10 - 1000 MHz	dB	—	—	±1.0,-0.8
1 dB Compression	Output Power	10 - 1000 MHz 100 - 1000 MHz	dBm dBm	+14 +17	— —	— —
Noise Figure	—	10 - 1000 MHz 10 - 500 MHz	dB dB	— —	— —	5.5 4.0
Reverse Transmission	—	10 - 1000 MHz	dB	—	-13.5	-11.0
VSWR	—	10 - 1000 MHz 10 - 500 MHz	Ratio Ratio	— —	— —	3:1 2:1
Output IP ₂	Two-Tone inputs up to +5 dBm	10 - 1000 MHz	dBm	+38	—	—
Output IP ₃	Two-Tone inputs up to +4 dBm	10 - 1000 MHz	dBm	+26	—	—
Vbias	—	—	VDC	+14.5	+15.0	+15.5
Ibias	Vbias = +15.0 VDC	—	mA	—	50	60
Power Dissipation	@ +15 V Bias	—	mW	—	750	—

2. All specifications apply when operated at +15 VDC, with 50 ohms source and load impedance.

3. Heat Sinking: Operation at case temperature above 95°C is not recommended. Heat sinking adequate to dissipate 0.8W must be provided in use.

S-Parameter Data

Frequency (MHz)	S11 MAG/ANG	S21 MAG/ANG	S12 MAG/ANG	S22 MAG/ANG
10	0.03/59.0	3.53/-160.8	0.21/-168.6	0.04/60.4
20	0.02/107.8	3.42/-171.3	0.22/-175.4	0.04/94.5
50	0.03/81.9	3.43/179.0	0.22/177.3	0.04/83.4
100	0.04/55.5	3.47/171.3	0.22/170.1	0.05/61.5
200	0.07/30.2	3.48/157.2	0.22/157.5	0.08/36.2
400	0.10/-18.6	3.50/131.8	0.22/134.3	0.11/-1.5
600	0.14/-64.1	3.54/106.9	0.23/111.8	0.14/-32.1
800	0.17/-115.9	3.49/82.1	0.23/90.6	0.16/-62.0
1000	0.21/162.9	3.51/55.5	0.23/69.3	0.18/-89.9

2

ADVANCED: Data Sheets contain information regarding a product M/A-COM Technology Solutions is considering for development. Performance is based on target specifications, simulated results, and/or prototype measurements. Commitment to develop is not guaranteed.

PRELIMINARY: Data Sheets contain information regarding a product M/A-COM Technology Solutions has under development. Performance is based on engineering tests. Specifications are typical. Mechanical outline has been fixed. Engineering samples and/or test data may be available. Commitment to produce in volume is not guaranteed.

• **North America** Tel: 800.366.2266 • **Europe** Tel: +353.21.244.6400
• **India** Tel: +91.80.4155721 • **China** Tel: +86.21.2407.1588

Visit www.macomtech.com for additional data sheets and product information.

M/A-COM Technology Solutions Inc. and its affiliates reserve the right to make changes to the product(s) or information contained herein without notice.

Typical Performance Curves

